

**Tributary Unit Payload Processor for 9953 Mbit/s**

**FEATURES**

- Configurable, multi-channel payload processor for aligning SONET virtual tributaries (VTs) or SDH tributary units (TUs) in an STS-192/STM-64 or STS-48/STM-16 data stream.
- Supports High Order (STS/AU) pointer processing, payload processing, and path termination/monitoring.
- Supports Low Order (VT/TU) pointer processing, payload processing, and path monitoring.
- On the line side, provides working Serial Receive and Transmit ESSI (Extended SONET Serial Interface) CML links. Links are configurable as:
  - 4xSTS-48/STM-16 2488.32 Mbit/s SONET/SDH framed interfaces; or
  - 4xSTS-12/STM-4 622.08 Mbit/s SONET/SDH framed interfaces.
- On the system side, provides working Add and Drop Serial ESSI links. Links are configurable as:
  - 4xSTS-48/STM-16 2488.32 Mbit/s SONET/SDH framed interfaces; or
  - 4xSTS-12/STM-4 622.08 Mbit/s SONET/SDH framed interfaces.
- Independently configurable (2488.32 Mbit/s or 622.08 Mbit/s) Line and System Interfaces.
- Provides a set of Ingress and Egress shared protection links.
- Provides a per-link Space switch on egress interfaces.
- Provides a steady-state latency of:
  - 21  $\mu$ s from line Receive to system DROP for VT1.5.
  - 2.5  $\mu$ s from system ADD to line TX.
- Provides hardware based Message Assisted Protection Switching (MAPS) support to work with a centralized fabric (e.g. PM5370 WSE 40).
- Supports independent Line Receive and System Drop transport frame alignment for high-order traffic.
- Supports independent transport, high-order payload and tributary multi-frame alignments for low-order traffic.
- Supports independent Line Transmit and System Add transport frame alignments.
- On the receive path, provides optional SDH payload conversion of:
  - AU4/VC4/TUG3/TU3/VC3/C3 to AU3/VC3/C3; or
  - AU3/VC3/C3 to AU4/VC4/TUG3/TU3/VC3/C3; or
  - AU4/VC4/TUG3/TUG2 to AU3/VC3/TUG2; or
  - AU3/VC3/TUG2 to AU4/VC4/TUG3/TUG2.
- On the transmit path, provides optional SDH payload conversion of:
  - AU3/VC3/C3 to AU4/VC4/TUG3/TU3/VC3/C3; or
  - AU4/VC4/TUG3/TUG2 to AU3/VC3/TUG2; or
  - AU3/VC3/TUG2 to AU4/VC4/TUG3/TUG2.
- Allows for low order (VT/TU) processing bypass.
- Supports high-order ESSI transport overhead transparency.
- Supports line and system diagnostic and facility loopbacks.
- Provides optional PRBS generation and monitoring features for ESSI offline link verification.
- Provides a generic 16-bit microprocessor bus interface for configuration, control, and status monitoring.
- Provides a standard 5-signal IEEE 1149.1 JTAG test port for boundary scan test purposes.
- Implemented in a 1.2 V core and 2.5 V I/O 0.13 $\mu$ m CMOS technology. Inputs are 3.3 V tolerant.
- Packaged in a 672-ball FCBGA top-hat, 27 mm x 27 mm.

**BLOCK DIAGRAM**

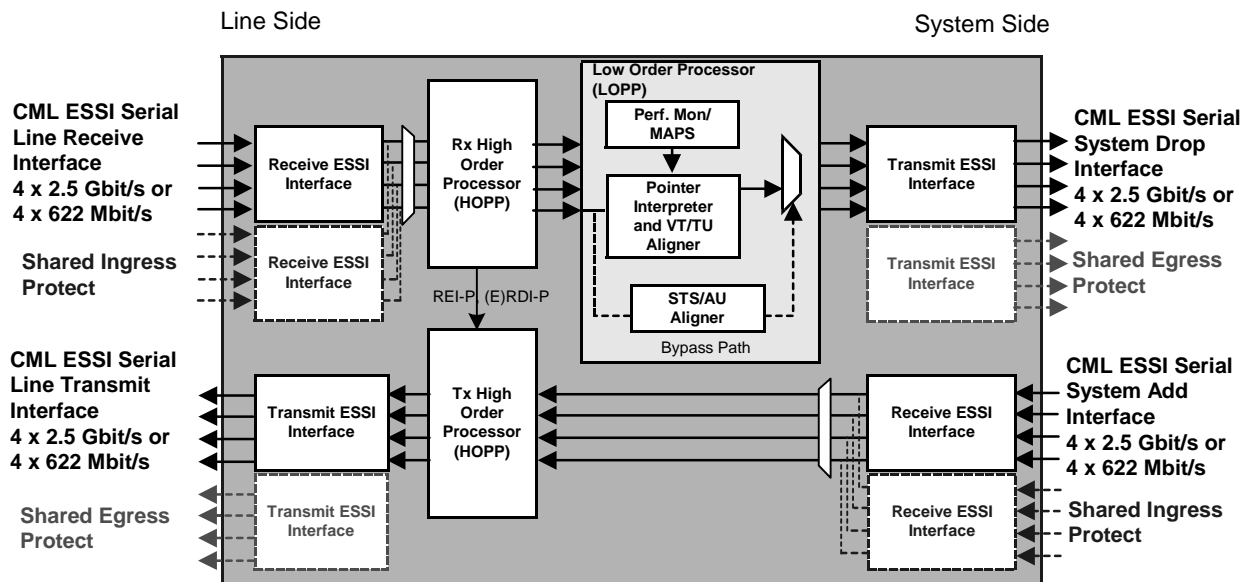

# Tributary Unit Payload Processor for 9953 Mbit/s

- Power when full bandwidth is used (OC-192/STM-64 applications using 2.488 Mbit/s links) is 6.91 W typical.
- Power when 1/4 bandwidth is used (OC-48/STM-16 applications using 622 Mbit/s links) is 2.64 W typical.

## APPLICATIONS

- SONET/SDH Add-Drop Multiplexer (ADM).
- SONET/SDH Digital Cross-connect (DCC).
- Multi-service Provisioning Platforms (MSPP).
- Multi-service ADM (MS-ADM).
- Multi-Service Switch.
- Optical Access Mux.
- Terminal Multiplexers.

## TYPICAL APPLICATIONS

### OC-192/STM-64 OPTICAL CROSS-CONNECT WITH 40G VT/TU CROSS-CONNECT SERVER CARD

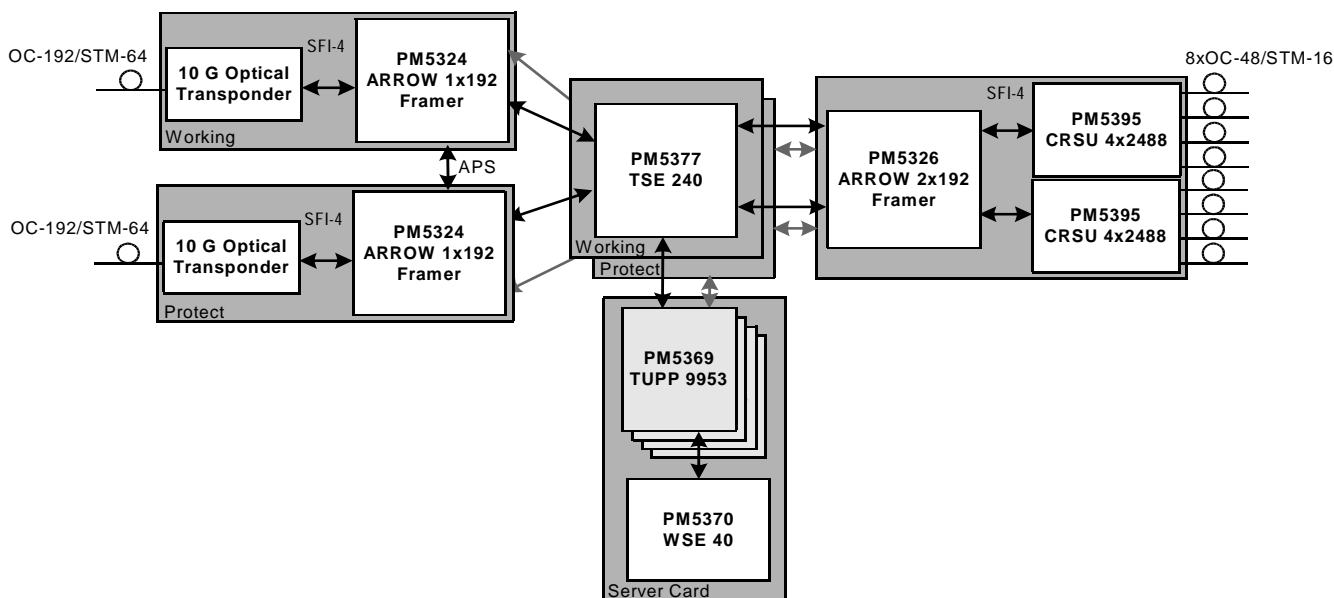

### OC-48/STM-16 VT/TU ADM / CROSS-CONNECT

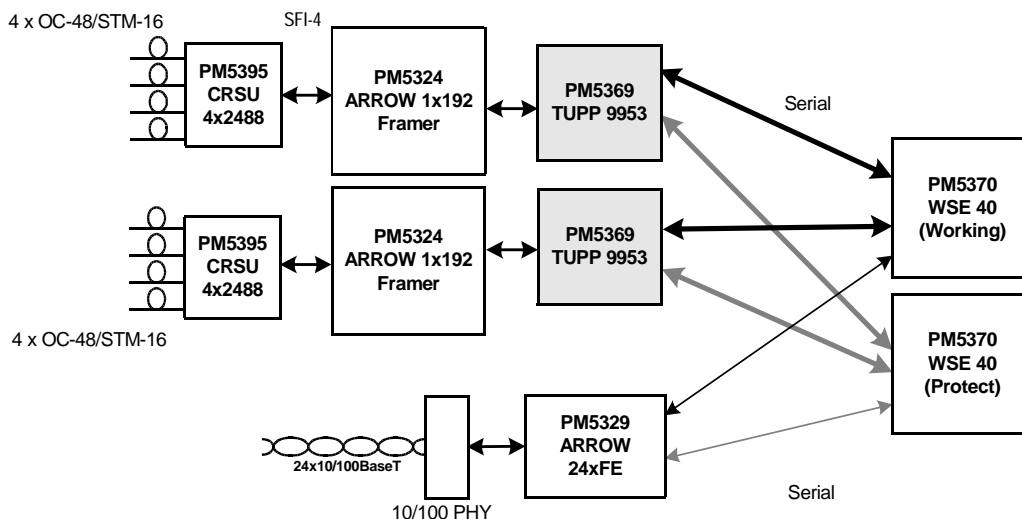

Head Office:  
 PMC-Sierra, Inc.  
 8555 Baxter Place  
 Burnaby, B.C. V5A 4V7  
 Canada  
 Tel: +1.604.415.6000  
 Fax: +1.604.415.6200

To order documentation,  
 send email to:  
 document@pmc-sierra.com  
 or contact the head office,  
 Attn: Document Coordinator

All product documentation is available on our web site at:  
<http://www.pmc-sierra.com>  
 For corporate information,  
 send email to:  
 info@pmc-sierra.com

PMC-202003 (R5)  
 © Copyright PMC-Sierra, Inc. 2004. All rights reserved.

For a complete list of PMC-Sierra's trademarks and registered trademarks, visit: <http://www.pmc-sierra.com/legal>