

# DATA SHEET

## **MKP 338 2**

**Interference suppression film  
capacitors**

Product specification  
Supersedes data of 2000-06-08  
File under BCcomponents, BC05

2000 Sep 11

# Interference suppression film capacitors

# MKP 338 2

## MKP RADIAL POTTED TYPE

PITCH 7.5/10/15/22.5/27.5 mm  
 PITCH 7.5 mm (bent back leads)

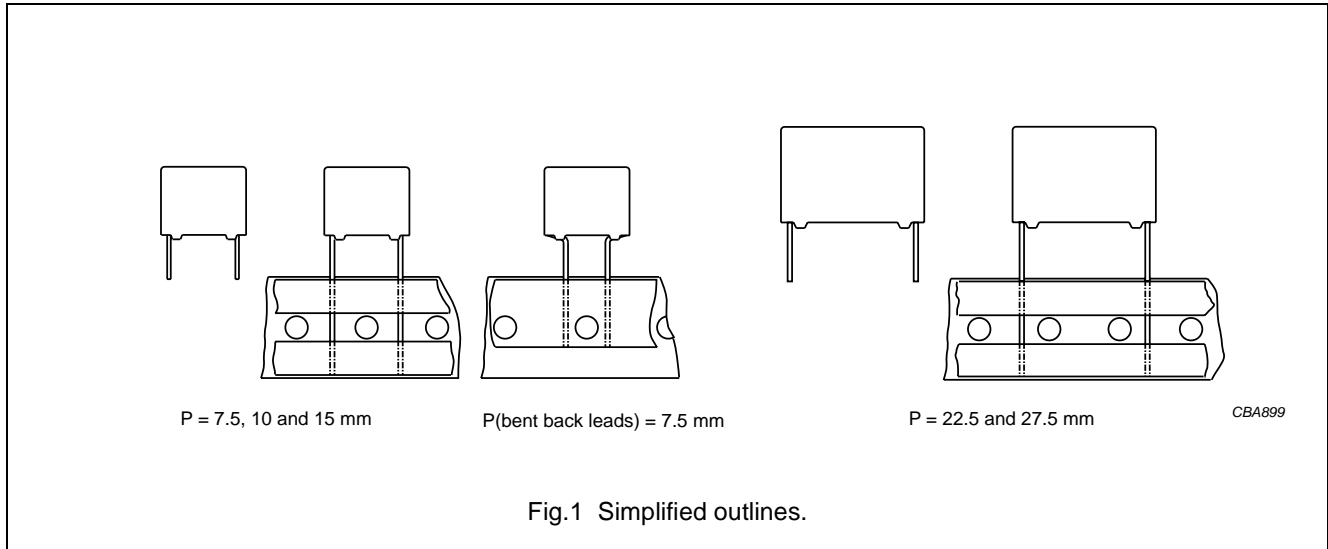

### FEATURES

- 7.5 to 27.5 mm lead pitch
- Supplied loose in box, taped on ammpack or reel
- Consists of a low-inductive wound cell of metallized polypropylene film, potted in a flame-retardant case.

### APPLICATIONS

- For X2 electromagnetic interference suppression
- Specially designed to meet the REQUIREMENTS of the "IEC 60384-14 2<sup>nd</sup> edition and EN 132400", requiring for X2 a 2.5 kV peak pulse voltage test and both UL1414 and CSA-C22.2 No 1 specifications.

### DETAIL SPECIFICATION

For more detailed data and test requirements see "Type detail specification HQN-384-14/111".

### QUICK REFERENCE DATA

DESCRIPTION	VALUE
Capacitance range (E12 series)	1 nF to 3.3 μF
Capacitance tolerance	±20%; ±10%; ±5%
Rated (AC) voltage, 50 to 60 Hz	275 V
Rated (DC) voltage	630 V
Climatic category	55/105/56/B
Rated temperature	105 °C
Maximum application temperature	105 °C
Reference specifications	IEC 60384-14 2 <sup>nd</sup> edition and EN 132400
Safety approvals:	
250 V	CSA-C22.2 No 1; UL1414; note 2
275 V	CSA-C22.2 No 8; note 1
305 V	SEV; VDE; FI; N; D; S; IMQ; ÖVE; CCEE; note 2
305 V	UL1283; note 2
Materials	qualified in accordance with UL94V-O
Safety class	X2













### Notes

1. Pending.
2. Approved.

## Interference suppression film capacitors

MKP 338 2

## SAFETY APPROVALS

SAFETY APPROVALS (X2)		VOLTAGE	VALUE	FILE NUMBERS
	UL1414	250 V (AC)	1 nF to 1 µF	E112471
	UL1283	305 V (AC)	1 nF to 3.3 µF	E109565
	CSA-C22.2 No.1	250 V (AC)	1 nF to 1 µF	LR94054
	CSA-C22.2 No.8	275 V (AC)	1 nF to 3.3 µF	pending
	SEV (EN132400)	275 V (AC)	1 nF to 3.3 µF	99,6 60107,02
	VDE (EN132400)	275 V (AC)	1 nF to 3.3 µF	115223
	FI (EN132400)	275 V (AC)	1 nF to 3.3 µF	FI 11681
	NEMKO (EN132400)	275 V (AC)	1 nF to 3.3 µF	P99102661
	DEMKO (EN132400)	275 V (AC)	1 nF to 3.3 µF	99-03462
	SEMKO (EN132400)	275 V (AC)	1 nF to 3.3 µF	9839136/02
	IMQ (EN132400)	275 V (AC)	1 nF to 3.3 µF	V4693
	ÖVE (EN132400)	275 V (AC)	1 nF to 3.3 µF	E260-009
	CCEE	275 V (AC)	1 nF to 3.3 µF	CH0038043-99

# Interference suppression film capacitors

MKP 338 2

## COMPOSITION OF CATALOGUE NUMBER

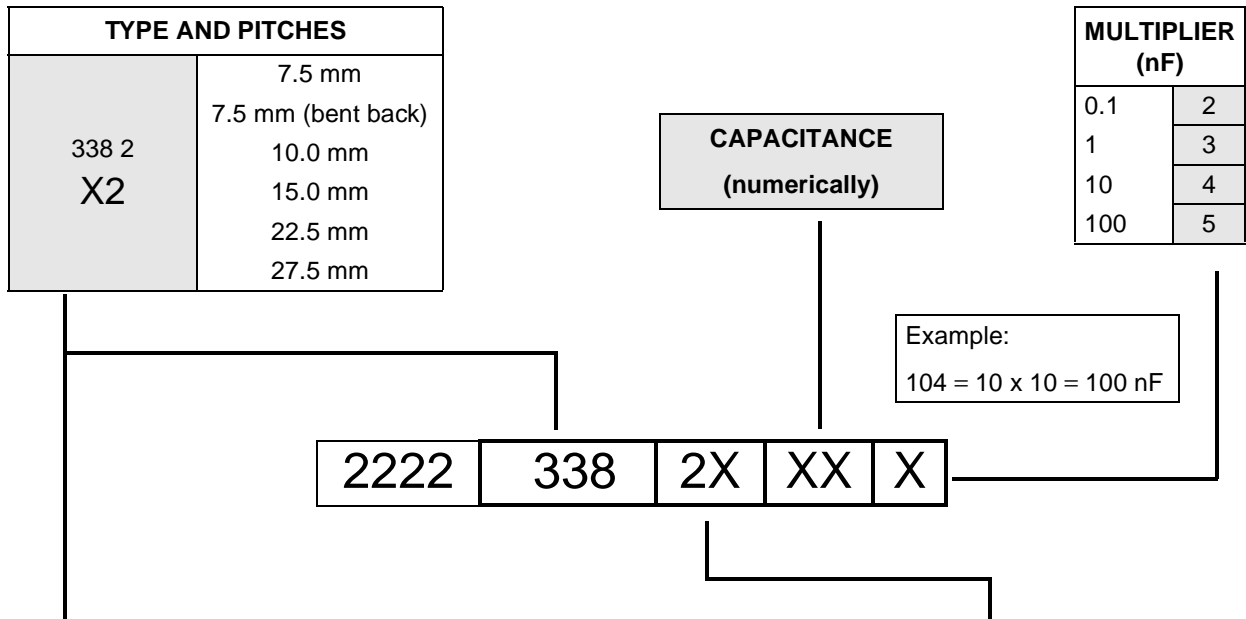

TYPE	PACKAGING <sup>(1)</sup>	STANDARD DIMENSIONS		PREFERRED TYPES	
338 2 X2	loose in box	lead length 3.5 mm	±20%	2222 338 20...	see Handbook
		lead length 5.0 mm		2222 338 22...	
		lead length 25.0 mm		2222 338 24...	
	taped	pitch = 7.5 mm or bent back to 7.5 mm		2222 338 26...	
		ALTERNATIVE LARGER PITCH SIZES		ON REQUEST	
338 2 X2	loose in box	lead length 3.5 mm	±20%	2222 338 21...	see Datasheet
		lead length 5.0 mm		2222 338 23...	
		lead length 25.0 mm		2222 338 25...	
	taped	H = 18.5 mm; for P <sub>0</sub> = 12.7 mm; note 2		2222 338 27...	
		ALTERNATIVE C-TOL		ON REQUEST	
338 2 X2	loose in box	lead length 3.5 mm	±10%	2222 338 2....	see Type detail specification
			±5%	2222 338 2....	
		lead length 5.0 mm	±10%	2222 338 2....	
			±5%	2222 338 2....	
		lead length 25.0 mm	±10%	2222 338 2....	
			±5%	2222 338 2....	
	taped	pitch = 7.5 mm or bent back to 7.5 mm	±10%	2222 338 2....	
			±5%	2222 338 2....	
	H = 18.5 mm; for P <sub>0</sub> = 12.7 mm; note 2	±10%	2222 338 2....		
		±5%	2222 338 2....		

### Notes

- 1) For SPQ refer to this handbook, chapter "Packaging information"; taped on reel pitch = 27.5 mm is not available.
- 2) H = in-tape height; for detailed specifications refer to this handbook, chapter "Packaging information".

Interference suppression film capacitors

MKP 338 2

MKP 338 2 GENERAL DATA

PITCH 7.5/10 mm  
 PITCH 7.5 mm (bent back leads)

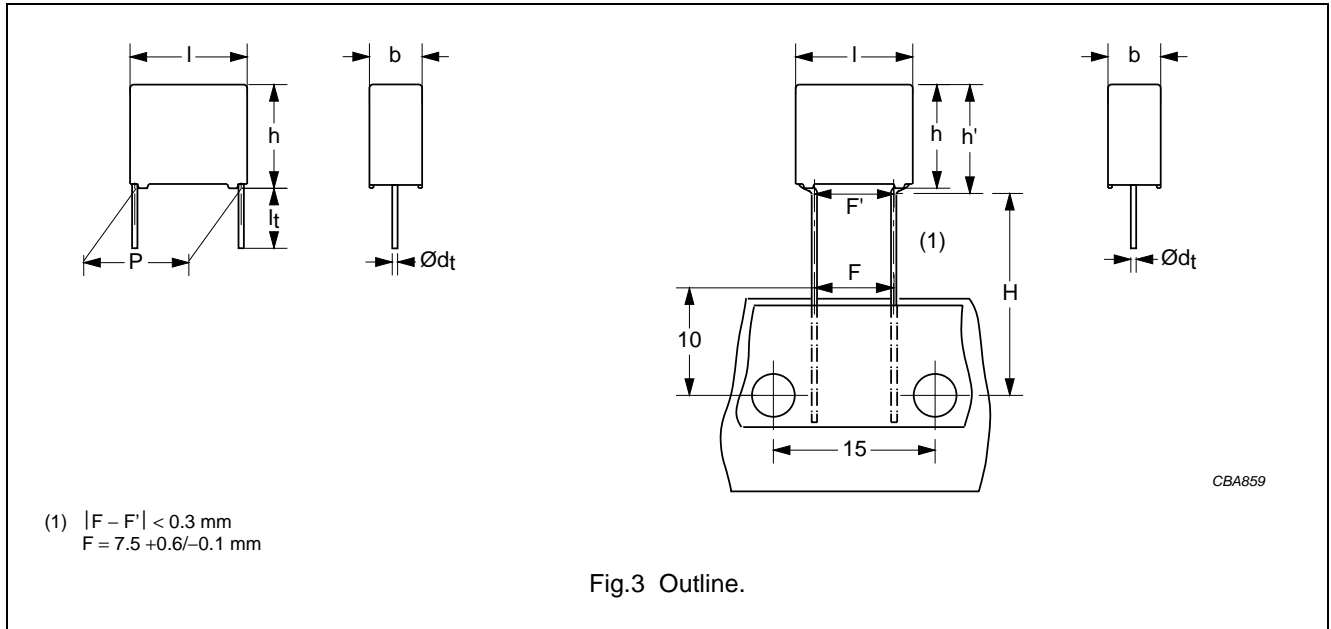

Specific reference data for the 275 V AC (X2) capacitors

DESCRIPTION	VALUE		
	at 1 kHz	at 10 kHz	at 100 kHz
Tangent of loss angle: $C \leq 100 \text{ nF}$	$\leq 10 \times 10^{-4}$	$\leq 20 \times 10^{-4}$	$\leq 100 \times 10^{-4}$
Rated voltage pulse slope (dU/dt)R at 385 V (DC)	100 V/ $\mu\text{s}$		
R between leads, for $C \leq 0.33 \mu\text{F}$ at 100 V; 1 minute	$> 15000 \text{ M}\Omega$		
R between leads and case; 100 V; 1 minute	$> 30000 \text{ M}\Omega$		
Withstanding (DC) voltage (cut off current 10 mA); rise time 100 V/s:	2200 V; 1 minute		
Withstanding (AC) voltage between leads and case	2050 V; 1 minute		

## Interference suppression film capacitors

MKP 338 2

 $U_{Rac} = 275 \text{ V (X2)}$ ;  $U_{Rdc} = 630 \text{ V}$ 

C ( $\mu\text{F}$ )	DIMENSIONS <sup>(1)</sup> b × h (h') × l (mm)	MASS (g)	CATALOGUE NUMBER				
			LOOSE IN BOX			AMMOPACK OR REEL <sup>(2)</sup>	
			short leads		long leads		
			$l_t =$ 3.5+1/-0.5 mm	$l_t =$ 5.0 ±1.0mm	$l_t =$ 25.0 ±2.0mm		
			C-tol = ±20%			C-tol = ±20%	
			catalogue number <sup>(3)</sup>	last 5 digits <sup>(3)</sup>		last 5 digits <sup>(3)</sup>	
<b>Pitch = 7.5 ±0.4 mm; <math>d_t = 0.50 \pm 0.05 \text{ mm}</math></b>					<b>ammopack; pitch = 7.5 mm; <math>d_t = 0.50 \text{ mm}</math></b>		
0.001	4.0 × 9.0 × 10.0	0.5	2222 338 20102	.. 22102	.. 24102	.. 26102	
0.0015			2222 338 20152	.. 22152	.. 24152	.. 26152	
0.0022			2222 338 20222	.. 22222	.. 24222	.. 26222	
0.0033			2222 338 20332	.. 22332	.. 24332	.. 26332	
0.0047			2222 338 20472	.. 22472	.. 24472	.. 26472	
0.0068			2222 338 20682	.. 22682	.. 24682	.. 26682	
0.01			2222 338 20103	.. 22103	.. 24103	.. 26103	
0.015			2222 338 20153	.. 22153	.. 24153	.. 26153	
0.022			2222 338 20223	.. 22223	.. 24223	.. 26223	
0.033	5.0 × 10.5 × 10.0	0.9	2222 338 20333	.. 22333	.. 24333	.. 26333	
0.047	6.0 × 11.5 × 10.0	1.0	2222 338 20473	.. 22473	.. 24473	.. 26473	
<b>Pitch = 10.0 ±0.4 mm; <math>d_t = 0.60 \pm 0.06 \text{ mm}</math></b>					<b>reel; pitch = 7.5 mm (bent back); <math>d_t = 0.60 \text{ mm}</math></b>		
0.068	6.0 × 12.0 (14.0) × 12.5	1.3	2222 338 20683	.. 22683	.. 24683	.. 26683	
0.1			2222 338 20104	.. 22104	.. 24104	.. 26104	

## Notes

- Dimensions in brackets for bent back leads.
- H = in-tape height;  $P_0$  = sprocket hole distance; for detailed specifications refer to this handbook, chapter "Packaging information".
  - For pitch = 7.5 mm: H = 18.5 mm and  $P_0 = 12.7 \text{ mm}$ .
  - For pitch = 7.5 mm (bent back): H = 16.0 mm and  $P_0 = 15.0 \text{ mm}$ .  
The reel diameter = 500 mm; reel diameter = 356 mm is available on request.
- The shading indicates preferred types.

Interference suppression film capacitors

MKP 338 2

MKP 338 2 GENERAL DATA

PITCH 15/22.5/27.5 mm  
 PITCH 7.5 mm (bent back leads)

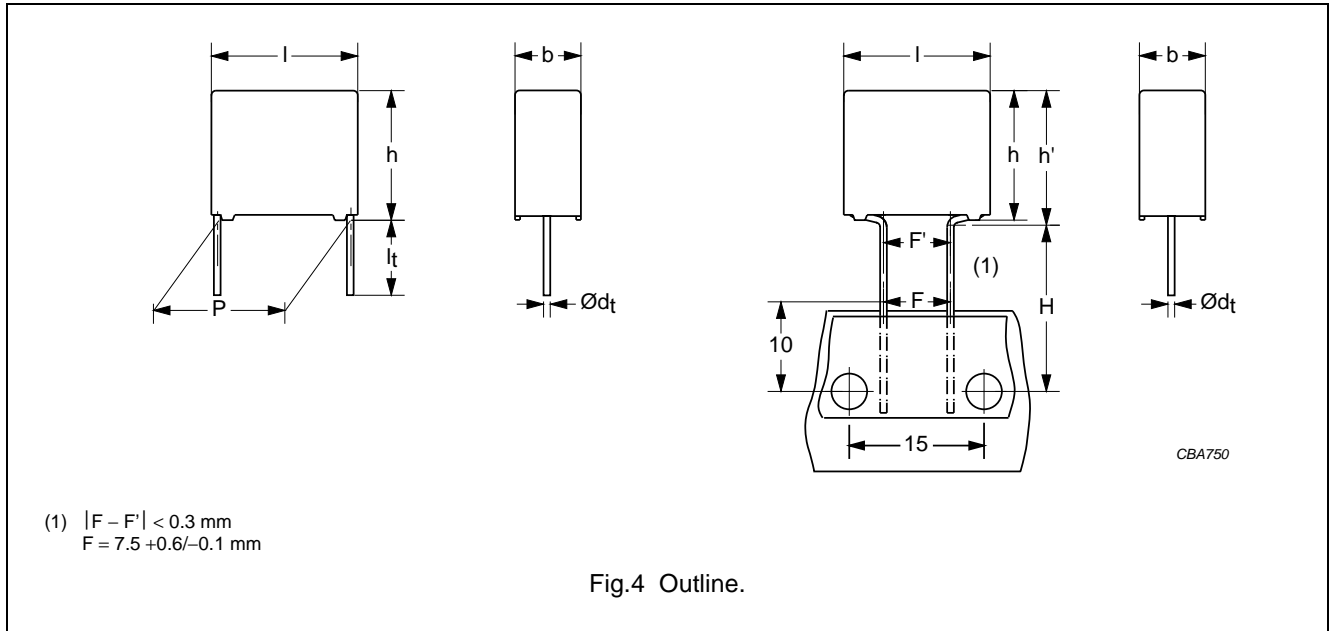

Specific reference data for the 275 V AC (X2) capacitors

DESCRIPTION	VALUE		
	at 1 kHz	at 10 kHz	at 100 kHz
Tangent of loss angle: 100 nF < C ≤ 470 nF 470 nF < C ≤ 1 µF C > 1 µF	≤10 × 10 <sup>-4</sup> ≤20 × 10 <sup>-4</sup> ≤30 × 10 <sup>-4</sup>	≤20 × 10 <sup>-4</sup> ≤70 × 10 <sup>-4</sup> -	≤100 × 10 <sup>-4</sup> - -
Rated voltage pulse slope (dU/dt) <sub>R</sub> at 385 V (DC)	100 V/µs		
R between leads, for C ≤ 0.33 µF at 100 V; 1 minute	>15000 MΩ		
RC between leads, for C > 0.33 µF at 100 V; 1 minute	>5000 s		
R between leads and case; 100 V; 1 minute	>30000 MΩ		
Withstanding (DC) voltage (cut off current 10 mA); rise time 100 V/s: C ≤ 1 µF C > 1 µF	2200 V; 1 minute 1800 V; 1 minute		
Withstanding (AC) voltage between leads and case	2050 V; 1 minute		

## Interference suppression film capacitors

MKP 338 2

 $U_{Rac} = 275 \text{ V (X2)}$ ;  $U_{Rdc} = 630 \text{ V}$ 

C ( $\mu\text{F}$ )	DIMENSIONS <sup>(1)</sup> $b \times h (h') \times l$ (mm)	MASS (g)	CATALOGUE NUMBER				
			LOOSE IN BOX			REEL <sup>(2)(3)</sup>	
			short leads		long leads		
			$l_t =$ $3.5 \pm 0.3 \text{ mm}$	$l_t =$ $5.0 \pm 1.0 \text{ mm}$	$l_t =$ $25.0 \pm 2.0 \text{ mm}$		
			C-tol = $\pm 20\%$			C-tol = $\pm 20\%$	
			catalogue number <sup>(4)</sup>		last 5 digits <sup>(4)</sup>		last 5 digits <sup>(4)</sup>
<b>Pitch = <math>15.0 \pm 0.4 \text{ mm}</math>; <math>d_t = 0.80 \pm 0.08 \text{ mm}</math></b>					<b>pitch = 7.5 mm (bent back); <math>d_t = 0.80 \text{ mm}</math></b>		
0.15	$7.0 \times 13.5 (15.5) \times 17.5$	1.9	2222 338 20154	.. 22154	.. 24154	.. 26154	
0.22	$8.5 \times 15.0 (17.0) \times 17.5$	2.6	2222 338 20224	.. 22224	.. 24224	.. 26224	
0.33	$10.0 \times 16.5 (18.5) \times 17.5$	3.1	2222 338 20334	.. 22334	.. 24334	.. 26334	
<b>Pitch = <math>22.5 \pm 0.4 \text{ mm}</math>; <math>d_t = 0.80 \pm 0.08 \text{ mm}</math></b>							
0.47	$8.5 \times 18.0 \times 26.0$	4.4	2222 338 20474	.. 22474	.. 24474	not available	
0.68	$10.0 \times 19.5 \times 26.0$	5.5	2222 338 20684	.. 22684	.. 24684		
1	$12.0 \times 22.0 \times 26.0$	7.8	2222 338 20105	.. 22105	.. 24105		
<b>Pitch = <math>27.5 \pm 0.4 \text{ mm}</math>; <math>d_t = 0.80 \pm 0.08 \text{ mm}</math></b>							
1.5	$15.0 \times 25.0 \times 31.0$	12.8	2222 338 20155	.. 22155	.. 24155	not available	
2.2	$18.0 \times 28.0 \times 31.0$	17.2	2222 338 20225	.. 22225	.. 24225		
3.3	$21.0 \times 31.0 \times 31.0$	20.4	2222 338 20335	.. 22335	.. 24335		

## Notes

- Dimensions in brackets for bent back leads.
- H = in-tape height;  $P_0$  = sprocket hole distance; for detailed specifications refer to this handbook, chapter "Packaging information".
- For pitch = 7.5 mm (bent back): H = 16.0 mm and  $P_0 = 15.0 \text{ mm}$ .  
The reel diameter = 500 mm; reel diameter = 356 mm is available on request.
- The shading indicates preferred types.



## Interference suppression film capacitors

MKP 338 2

**CONSTRUCTION****Description**

- Low-inductive wound cell of metallized polypropylene (PP) film, potted with epoxy resin in a flame-retardant case
- Radial leads, solder-coated:
  - Copper clad steel wire for original pitch = 7.5 and 10 mm
  - Copper wire for original pitch = 15, 22.5 and 27.5 mm
- Small stand-off pips allow removal of solder flux etc. during cleaning of the printed-circuit board.

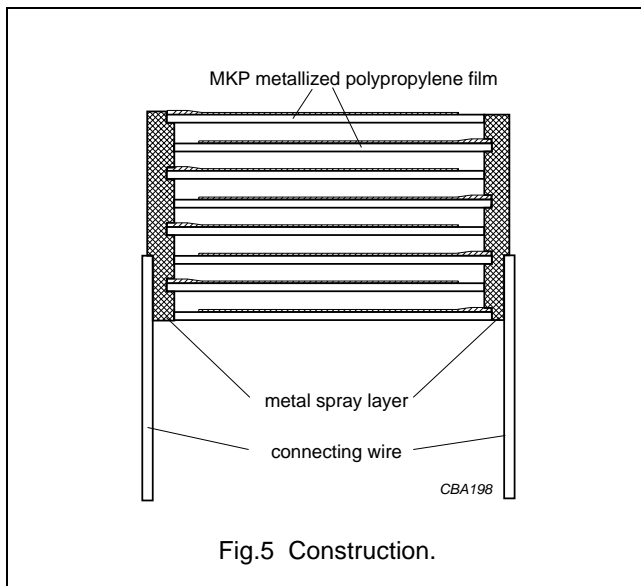
**Mounting****NORMAL USE**

The capacitors are designed for mounting on printed-circuit boards. The capacitors packed in bandoliers are designed for mounting on printed-circuit boards by means of automatic insertion machines.

For detailed tape specifications refer to this handbook, chapter "Packaging information".

**SPECIFIC METHOD OF MOUNTING TO WITHSTAND VIBRATION AND SHOCK**

In order to withstand vibration and shock tests, it must be ensured that the stand-off pips are in good contact with the printed-circuit board:

- For pitches  $\leq 15$  mm capacitors shall be mechanically fixed by the leads.
- For larger pitches the capacitors shall be mounted in the same way and the body clamped.

**SPACE REQUIREMENTS ON PRINTED-CIRCUIT BOARD**

The maximum length and width of film capacitors is shown in Fig.6:

- Eccentricity as in Fig.6. The maximum eccentricity is smaller than or equal to the lead diameter of the product concerned.
- Product height with seating plane as given by "IEC 60717" as reference:  $h_{\max} \leq h + 0.3$  mm or  $h_{\max} \leq h' + 0.3$  mm.

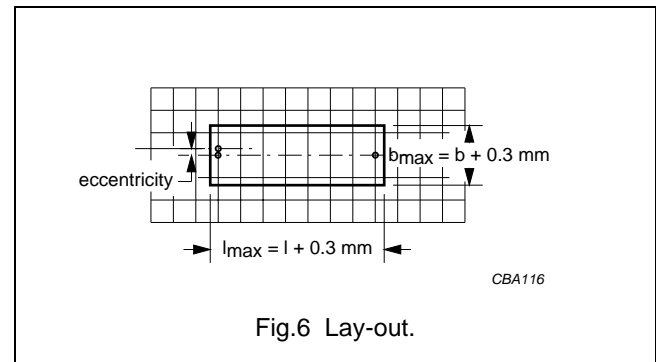
**Storage temperature**

- Storage temperature:  $T_{\text{stg}} = -25$  to  $+40$  °C with RH maximum 80% without condensation.

**RATINGS AND CHARACTERISTICS REFERENCE CONDITIONS**

Unless otherwise specified, all electrical values apply to an ambient temperature of  $23 \pm 1$  °C, an atmospheric pressure of 86 to 106 kPa and a relative humidity of  $50 \pm 2\%$ .

For reference testing, a conditioning period shall be applied over  $96 \pm 4$  hours by heating the products in a circulating air oven at the rated temperature and a relative humidity not exceeding 20%.

Interference suppression film capacitors

MKP 338 2

CHARACTERISTICS

Capacitance

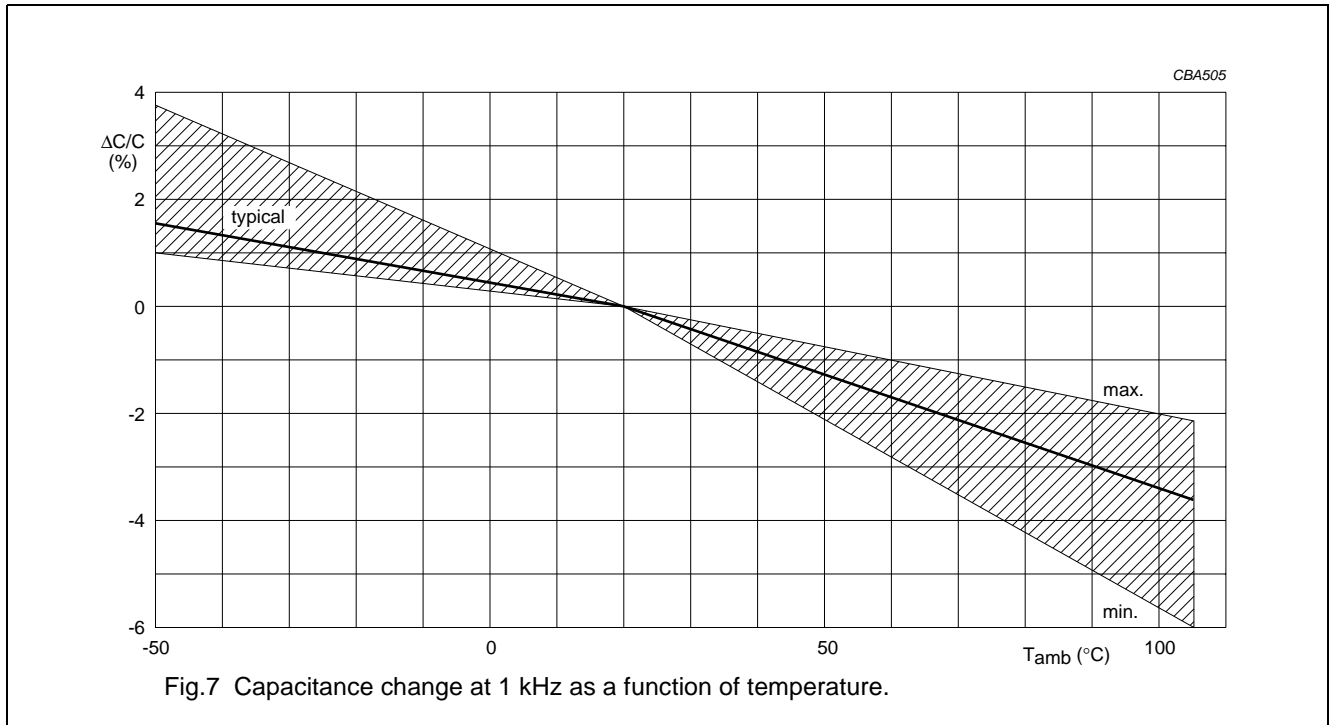

Tangent of loss angle

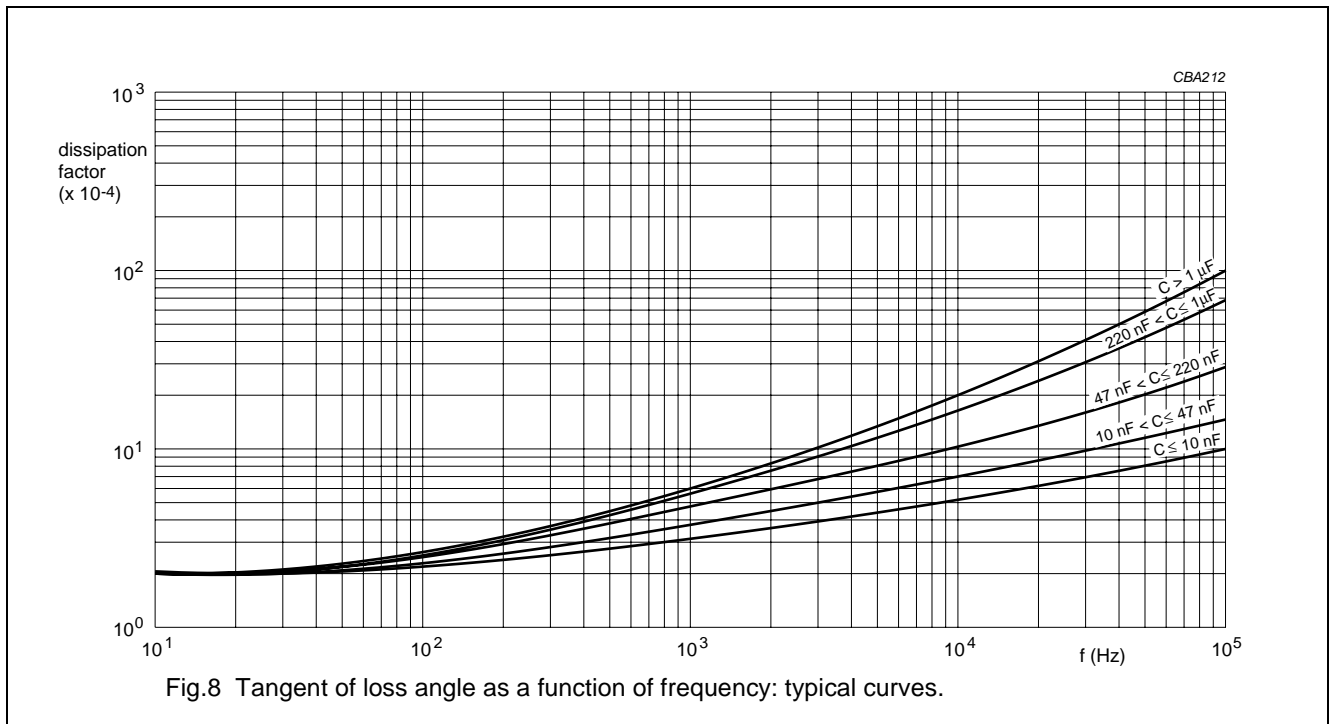

# Interference suppression film capacitors

# MKP 338 2

## Impedance

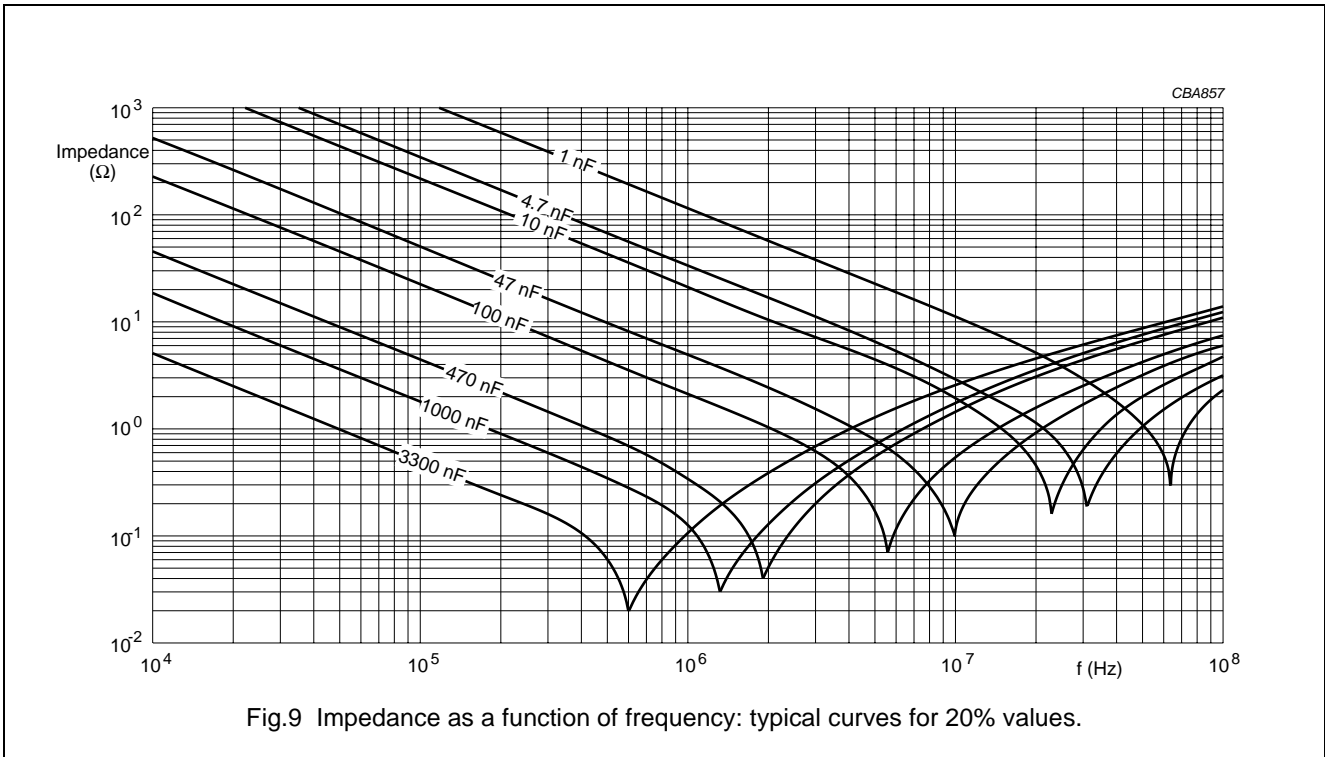

## Resonant frequency

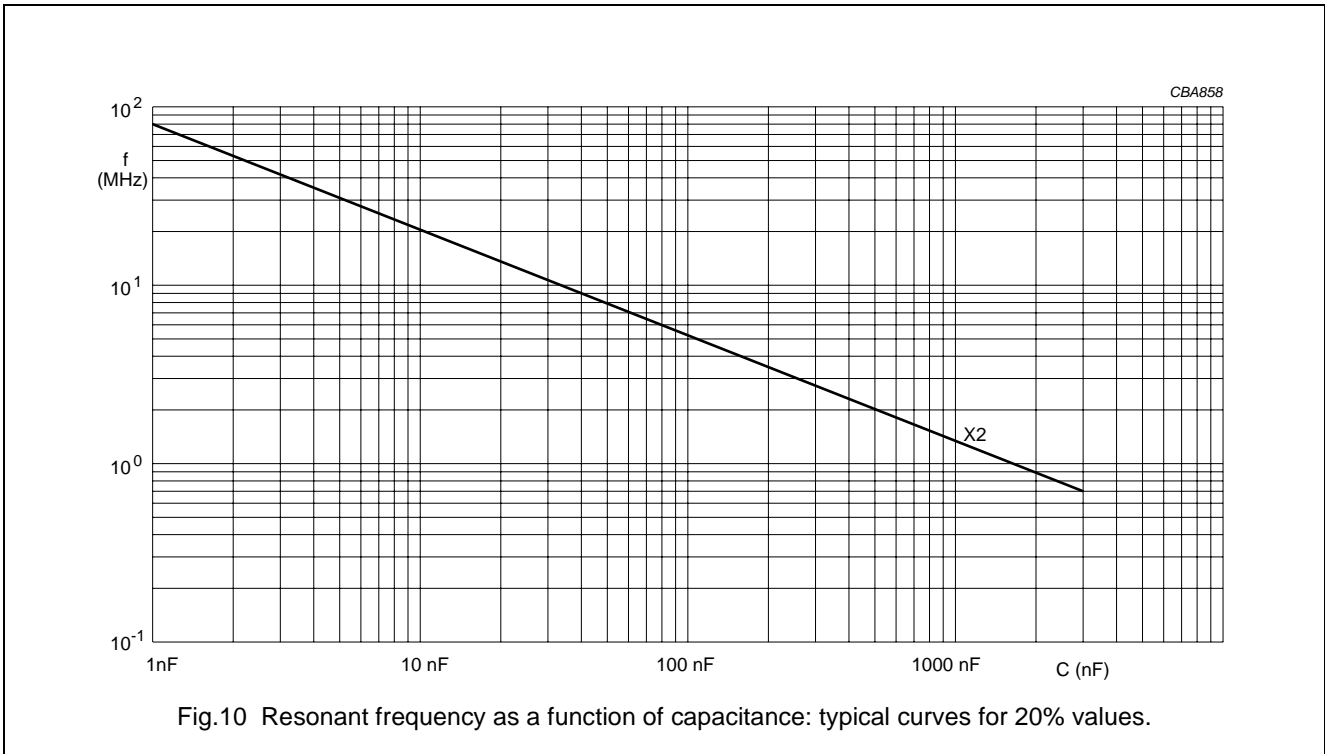

Interference suppression film capacitors

MKP 338 2

Maximum RMS voltage and AC current (sinewave) as a function of frequency for  $T_{amb} \leq 105\text{ }^{\circ}\text{C}$

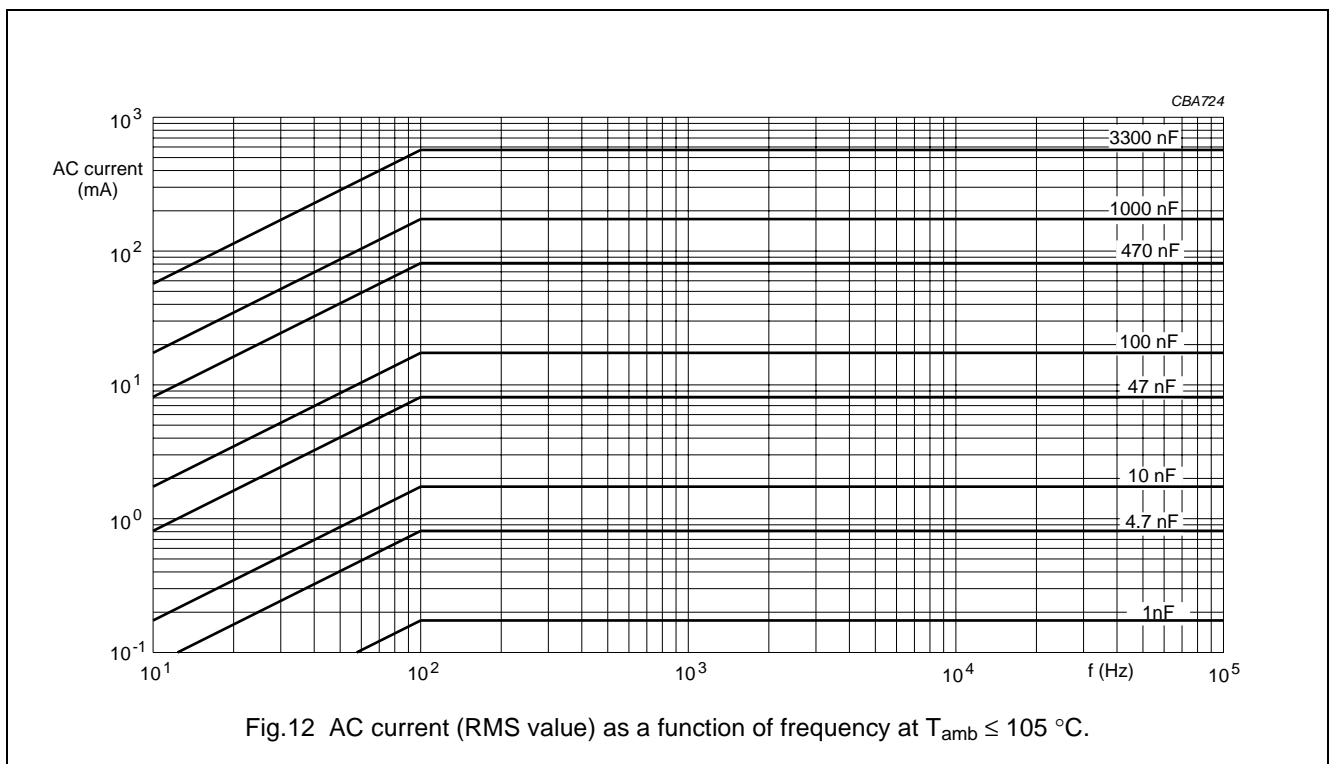
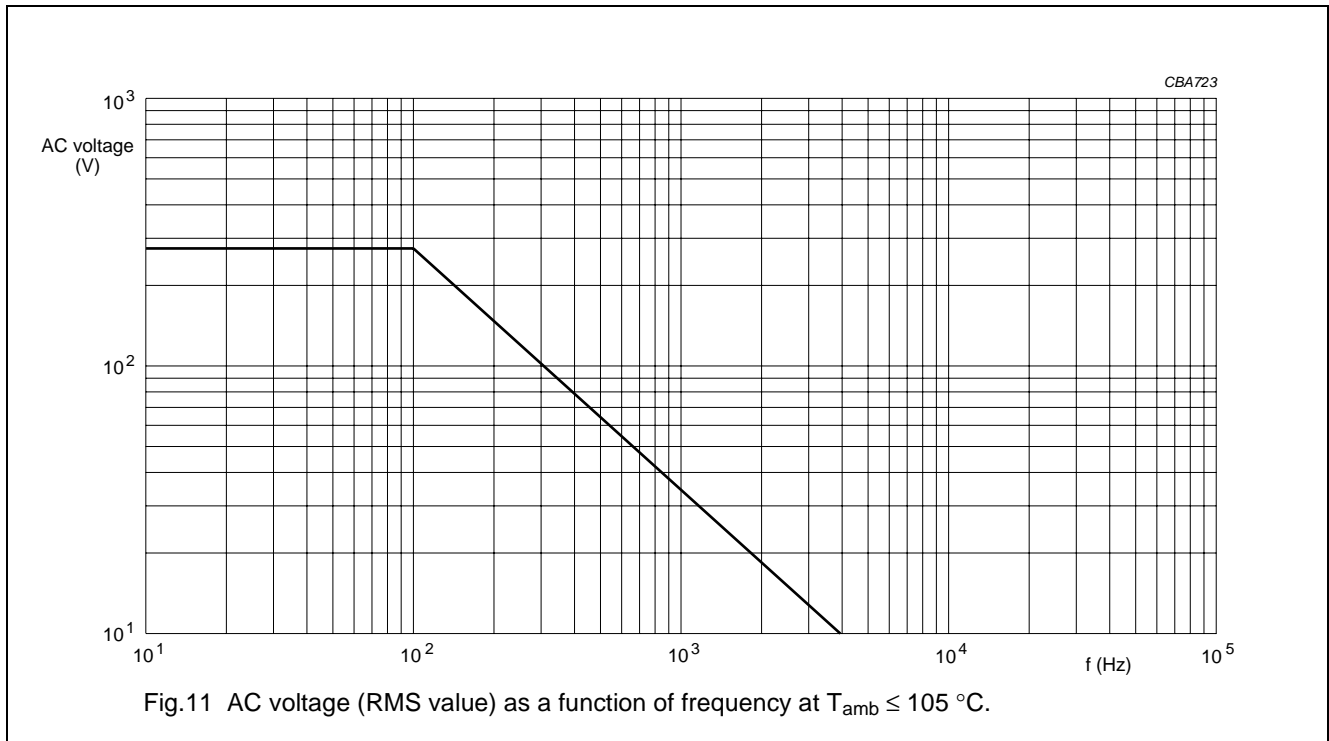

## Interference suppression film capacitors

MKP 338 2

## Insulation resistance

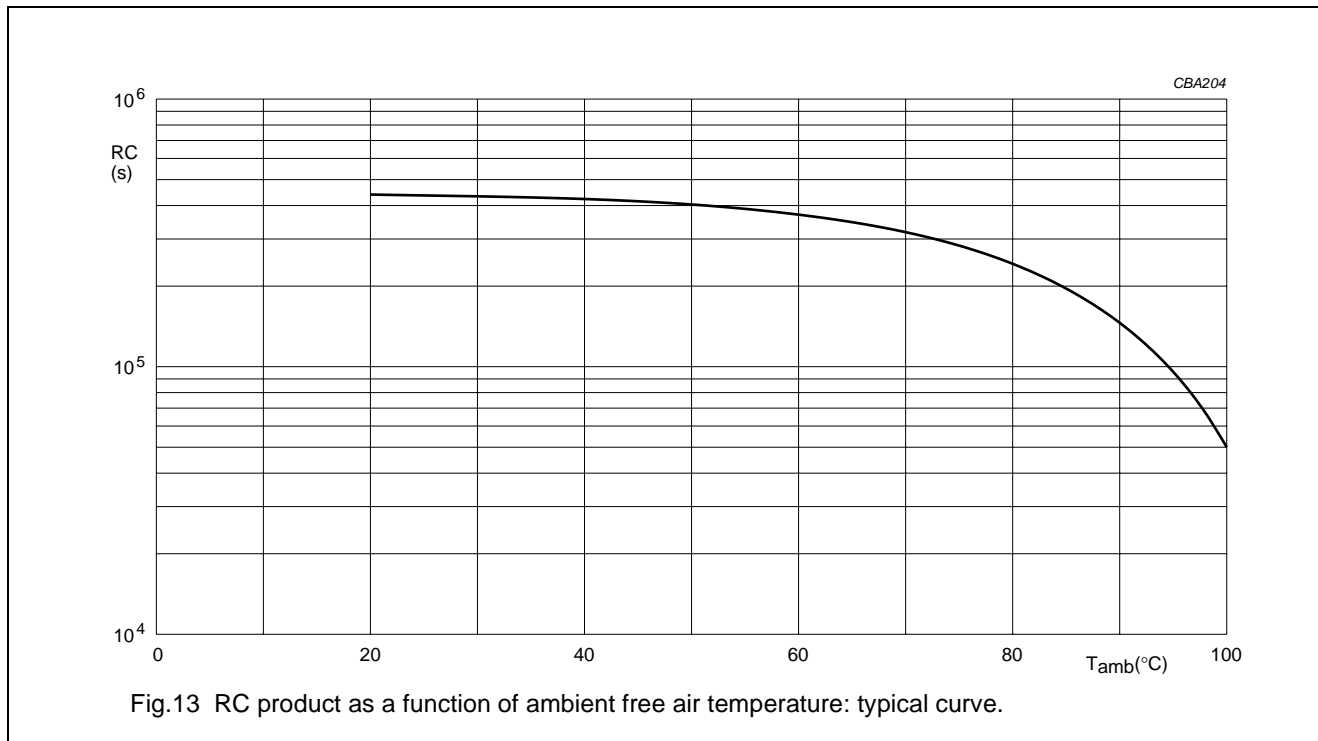

## APPLICATION NOTES

- For X2 electromagnetic interference suppression in across the line applications (50/60 Hz) with a maximum mains voltage of 275 V (AC).
- These capacitors are not intended for continuous pulse applications. For these situations, capacitors of the AC and pulse program must be used, such as: 2222 375 .....; 2222 383 ..... or 2222 479 .....
- The maximum ambient temperature must not exceed 105 °C.
- Rated voltage pulse slope:
  - If the pulse voltage is lower than the rated voltage, the values of the specific reference data can be multiplied by 385 V (DC) and divided by the applied voltage.



Interference suppression film capacitors

MKP 338 2

Package marking

The package containing the capacitors is marked as shown Fig.17.

**Barcode label marking**

LINE	MARKING EXPLANATION
1	Manufacturer's name
2	Country of origin
3	Sub-family
4	Type description and sub class
5	Capacitance value, tolerance, voltage and climatic category ("IEC 60068-1")
6	Safety approvals
7	Preference origin code: A Country of origin in code: 170 (Belgium) Responsible production centre: HQ Work order: WO Wage number of final inspection (only for capacitors with original pitch = 7.5 and 10 mm)
8	Product type description
9	Quantity and production period, year and week code
10	Product code (12NC)

Fig.17 Barcode label.

## Interference suppression film capacitors

MKP 338 2

## QUICK REFERENCE TEST REQUIREMENTS (see note 1)

TEST	PROCEDURE (quick reference)	REQUIREMENTS
<b>Robustness of leads</b>		
Tensile strength: "IEC 60068-2-21"	load 10 N; 10 s	no visible damage legible marking $ \Delta C/C  \leq 5\%$ $\Delta \tan \delta \leq 80 \times 10^{-4}$ ( $C \leq 1 \mu\text{F}$ ); note 2 $\Delta \tan \delta \leq 50 \times 10^{-4}$ ( $C > 1 \mu\text{F}$ ); note 2
Bending: "IEC 60068-2-21"	load 5 N; $4 \times 90^\circ$	
Resistance to soldering heat: "IEC 60068-2-20"	solder bath: 260 °C; 10 s	
Component solvent resistance	isopropyl alcohol; 23 °C; 5 minutes	
<b>Robustness of component</b>		
Rapid change of temperature: "IEC 60068-2-14"	5 cycles 1 cycle = 30 minutes at -55 °C and 30 minutes at 105 °C	$ \Delta C/C  \leq 5\%$ $\Delta \tan \delta \leq 80 \times 10^{-4}$ ( $C \leq 1 \mu\text{F}$ ); note 2 $\Delta \tan \delta \leq 50 \times 10^{-4}$ ( $C > 1 \mu\text{F}$ ); note 2
Vibration: "IEC 60068-2-6"	10 to 55 Hz; amplitude 0.75 mm; 6 hours	
Shock: "IEC 60068-2-27"	half sinewave; 490 m/s <sup>2</sup> ; 11 ms	
<b>Climatic sequence</b>		
Dry heat: "IEC 60068-2-2"	16 hours; 105 °C	$ \Delta C/C  \leq 5\%$ $\Delta \tan \delta \leq 80 \times 10^{-4}$ ( $C \leq 1 \mu\text{F}$ ); note 2 $\Delta \tan \delta \leq 50 \times 10^{-4}$ ( $C > 1 \mu\text{F}$ ); note 2 $R_{\text{ins}} \geq 50\%$ of specified value
Damp heat, cyclic, test Db, first cycle: "IEC 60068-2-30"		
Cold: "IEC 60068-2-1"	2 hours; -55 °C	
Damp heat, cyclic, test Db, remaining cycles: "IEC 60068-2-30"		
Voltage proof: "IEC 60384-14"	$V_p = 1200 \text{ V (DC)}$ ; 1 minute	
<b>Other applicable tests</b>		
Damp heat, steady state: "IEC 60068-2-3"	56 days; 40 °C; 90 to 95% RH no load $V_p = 1200 \text{ V (DC)}$ ; 1 minute	$ \Delta C/C  \leq 5\%$ $\Delta \tan \delta \leq 80 \times 10^{-4}$ ( $C \leq 1 \mu\text{F}$ ); note 2 $\Delta \tan \delta \leq 50 \times 10^{-4}$ ( $C > 1 \mu\text{F}$ ); note 2 $R_{\text{ins}} \geq 50\%$ of specified value
Endurance (AC): "IEC 60384-14"	$3 \times 2.5 \text{ kV}$ pulse voltage for X2; 1000 hours; $1.25 \times U_{\text{Rac}}$ at 105 °C; once per hour; 0.1 s; 1000 V (RMS) via resistor of 47 $\Omega$ ; $V_p = 1200 \text{ V (DC)}$ ; 1 minute	



## Interference suppression film capacitors

MKP 338 2

TEST	PROCEDURE (quick reference)	REQUIREMENTS
Charge and discharge: "IEC 60384-14"	10000 cycles; 5 ms; $1.5 \times dV/dt$	$ \Delta C/C  \leq 10\%$ $\Delta \tan \delta \leq 80 \times 10^{-4}$ ( $C \leq 1 \mu F$ ); note 2 $\Delta \tan \delta \leq 50 \times 10^{-4}$ ( $C > 1 \mu F$ ); note 2 $R_{ins} \geq 50\%$ of specified value
Passive flammability: "IEC 60384-14"	class B	no burning
Active flammability: "IEC 60384-14"	$20 \times 2.5$ kV discharge	no burning
Heat storage: "IEC 60384-14"	1000 hours; 105 °C	$ \Delta C/C  \leq 5\%$ $\Delta \tan \delta \leq 80 \times 10^{-4}$ ( $C \leq 1 \mu F$ ); note 2 $\Delta \tan \delta \leq 50 \times 10^{-4}$ ( $C > 1 \mu F$ ); note 2
Resistance to soldering heat with preheating: "IEC 60384-14"	preheating: 105 °C; solder bath: 260 °C; 10 s	$ \Delta C/C  \leq 5\%$ $\Delta \tan \delta \leq 80 \times 10^{-4}$ ( $C \leq 1 \mu F$ ); note 2 $\Delta \tan \delta \leq 50 \times 10^{-4}$ ( $C > 1 \mu F$ ); note 2
Active flammability test	voltage proof up to $2 \times$ peak impulse voltage of 4.13 or until breakdown (100 V/sec, current limited 2mA)  failed capacitors connected to a $250 V_{ac}$ power supply during 5 minutes.	no burning

**Notes**

1. For detailed information: see "Type detail specification HQN-384-14/111".
2. Measuring frequency 10 kHz for  $C \leq 1 \mu F$  and 1 kHz for  $C > 1 \mu F$ .