

# Infrared Remote Control Receiver Module

## IRM-36XXG Series

### Features

- Photo detector and preamplifier in one package
- High protection ability against EMI (Inner shield)
- High immunity against ambient light
- Circular lens to improve the receive characteristic.
- Line-up for various center carrier frequencies.
- Low voltage and low power consumption.
- Long reception distance & High sensitivity.
- Suitable burst length 300  $\mu$ s
- Pb free.
- The product itself will remain within RoHS compliant version.



### Descriptions

The device is a miniature type infrared remote control system receiver which has been developed and designed by utilizing the most updated IC technology. The PIN diode and preamplifier are assembled on lead frame, the epoxy package is designed as an IR filter. The demodulated output signal can directly be decoded by a microprocessor.

### Applications

- Light detecting portion of remote control
- AV instruments such as Audio, TV, VCR, CD, MD, etc.
- Home appliances such as Air-conditioner, Fan, etc.
- The other equipments with wireless remote control.
- CATV set top boxes
- Multi-media Equipment

PART	MATERIAL	COLOR
Chip	Silicon	---
Compound	Epoxy	Black

# Infrared Remote Control Receiver Module

## IRM-36XXG Series

### Package Dimensions

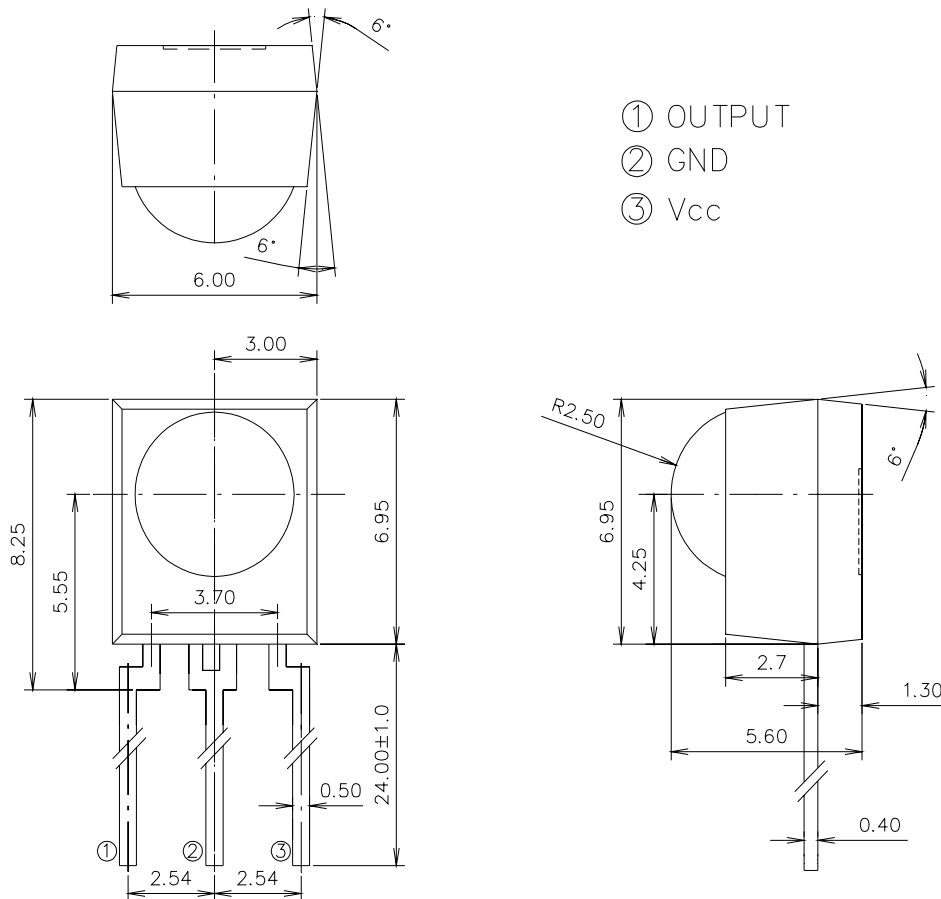

- Notes:**
1. All dimensions are in millimeters.
  2. Tolerances unless dimensions  $\pm 0.3\text{mm}$ .

### Available Types for Different Carrier Frequencies

Type	Carrier Frequency
IRM-3638G	38 kHz
IRM-3640G	40 kHz

# Infrared Remote Control Receiver Module

## IRM-36XXG Series

### Absolute Maximum Ratings (Ta=25 )

Parameter	Symbol	Rating	Unit	Notice
Supply Voltage	Vcc	0-6	V	
Operating Temperature	Topr	-20 ~ +80		
Storage Temperature	Tstg	-40 ~ +85		
Soldering Temperature	Tsol	260		4mm from mold body less than 10 seconds

### Recommended Operating Condition

Supply Voltage Rating: Vcc 2.7V to 5.5V

### Electro-Optical Characteristics (Ta=25 , and Vcc=3.0V)

Parameter	Symbol	MIN.	TYP.	MAX.	Unit	Condition
Consumption Current	Icc	---	0.7	1.5	mA	No signal input
Peak Wavelength	$\lambda_p$	---	940	---	nm	
Reception Distance	L <sub>0</sub>	14	---	---	m	At the ray axis *1
	L <sub>45</sub>	6	---	---		
Half Angle(Horizontal)	$\Theta_h$	---	45	---	deg	
Half Angle(Vertical)	$\Theta_v$	---	45	---	deg	
High Level Pulse Width	T <sub>H</sub>	450	---	750	$\mu$ s	
Low Level Pulse Width	T <sub>L</sub>	450	---	750	$\mu$ s	
High Level Output Voltage	V <sub>H</sub>	2.7	---	---	V	
Low Level Output Voltage	V <sub>L</sub>	---	0.2	0.5	V	

#### Notes:

\*1: The ray receiving surface at a vertex and relation to the ray axis in the range of  $\theta = 0^\circ$  and  $\theta = 45^\circ$ .

\*2: A range from 30cm to the arrival distance. Average value of 22 pulses.

# Infrared Remote Control Receiver Module

## IRM-36XXG Series

### Test Method :

The specified electro-optical characteristics is satisfied under the following Conditions at the controllable distance.

- ① Measurement place  
A place that is nothing of extreme light reflected in the room.
- ② External light  
Project the light of ordinary white fluorescent lamps which are not high Frequency lamps and must be less then 10 Lux at the module surface.  
( $E_e \leq 10\text{Lux}$ )
- ③ Standard transmitter  
A transmitter whose output is so adjusted as to  **$V_o=400\text{mVp-p}$**  and the output Wave form shown in Fig.-1. According to the measurement method shown in Fig.-2 the standard transmitter is specified.  
However, the infrared photodiode to be used for the transmitter should be  $\lambda_p=940\text{nm}$ ,  $\Delta\lambda=50\text{nm}$ . Regarding photo diode, sensitivity  $S=26\text{nA/Lx}$  in case light source temperature  $2856^\circ\text{K}$ ,  $E_e=100\text{Lx}$ ,  $V_r=5\text{V}$ .
- ④ Measuring system  
According to the measuring system shown in Fig.-3

### Block Diagram :

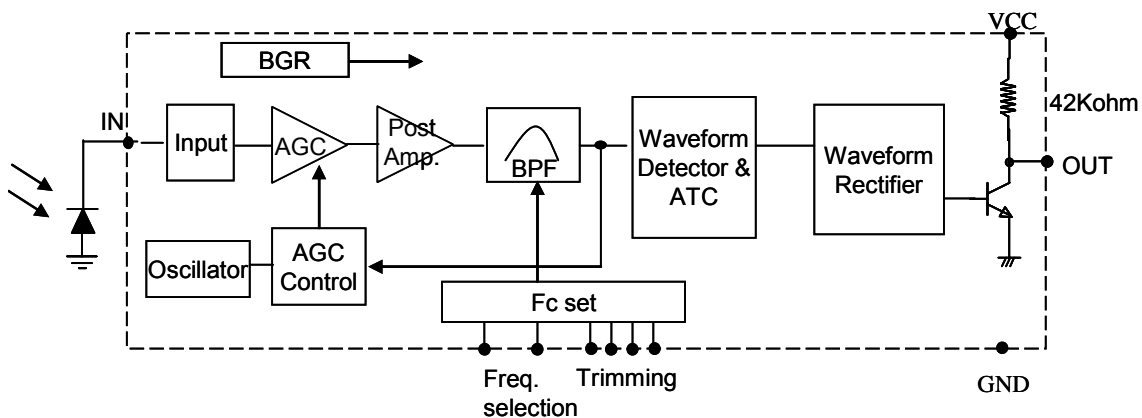

# Infrared Remote Control Receiver Module

## IRM-36XXG Series

### Application Circuit :

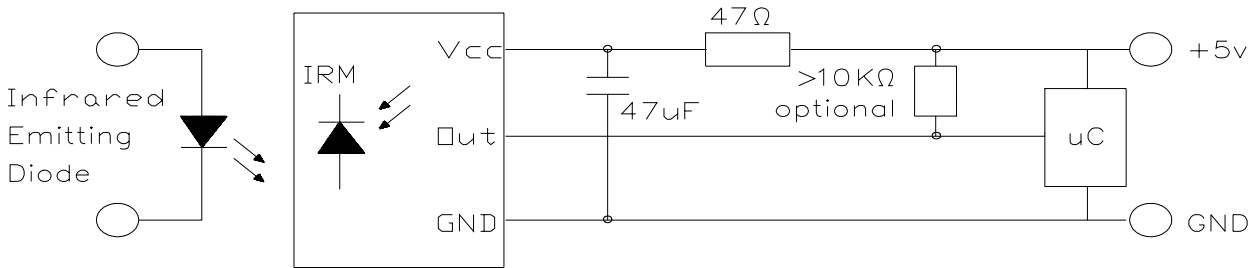

RC Filter should be connected closely between Vcc pin and GND pin.

Fig.-1 Transmitter Wave Form

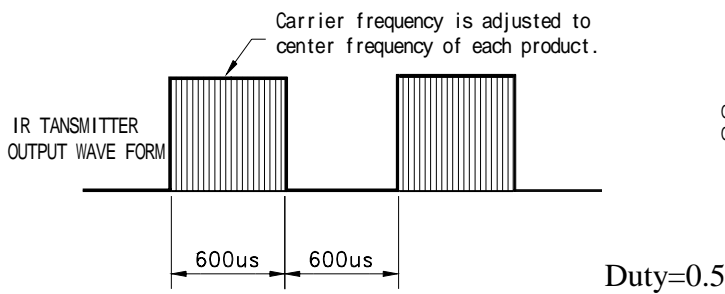

D.U.T output Pulse

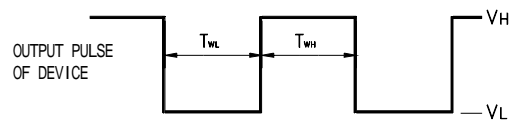

Fig.-2 Measuring Method

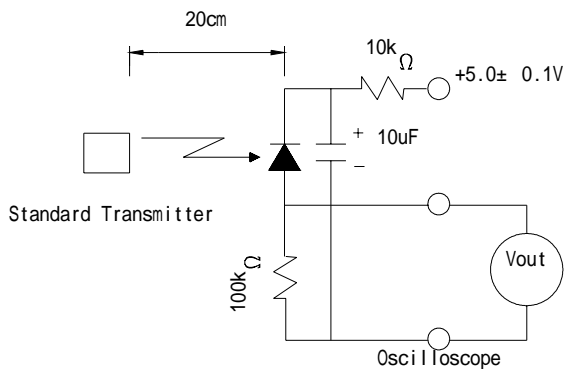
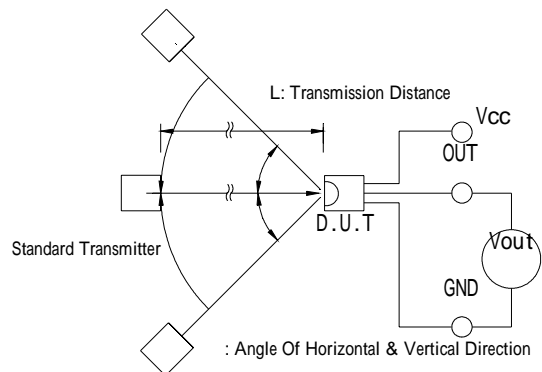

Fig.-3 Measuring System



# Infrared Remote Control Receiver Module

## IRM-36XXG Series

### The Notice of Application:

Transmission of remote control signal consist of four parts: Encode Part, IR Transmitter Source, IRM device, Decode Part

1. When IRM-36XXG code select frequency, it need to well understand the center system of encode part.
2. Strong or weak light of IR Transmitter can affect distance of transmission.
3. When using IRM-36XXG device, it requires the composition of code pattern to reach the demand as follows:

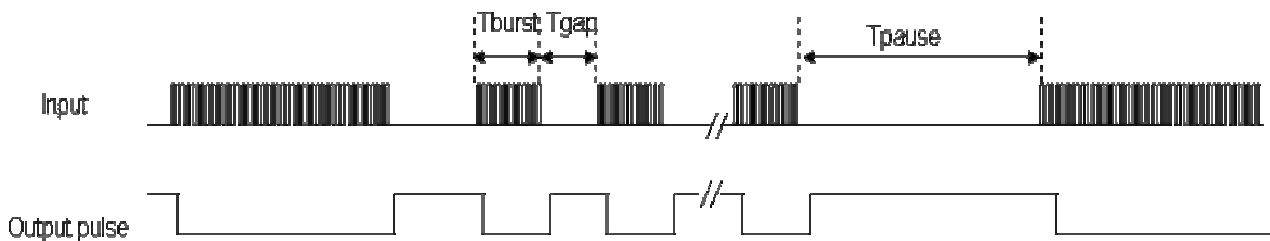

Minimum Burst length ( $T_{burst}$ )	Minimum Gap Time ( $T_{gap}$ )	Minimum data pause time ( $T_{pause}$ )
300 $\mu$ s	300 $\mu$ s	23 ms

4. It needs to ensure the translation range of decode part if it is applied to the pulse-width range.

If the above items hardly assure of its application, it'll cause NG (no good) message from the edge of signal.

# Infrared Remote Control Receiver Module

## IRM-36XXG Series

### IRM-36XXG Code Properties:

Characteristics	IRM-36XXG Series
NEC	+
RC5	+
RC6	+
Toshiba Micom Code	+
Sharp Code	+
Sony 12bit Code	+
Sony 15bit Code	-
Sony 20bit Code	-
RCA Code	-
RCMM Code	-
Matsushita Code	+
Mitsubishi Code	-
Zenith Code	+
JVC Code	+
Data Communication	-

Note: +; suitable, -; Not recommend.



# Infrared Remote Control Receiver Module

# IRM-36XXG Series

## Typical Electro-Optical Characteristics Curves

Fig.-1 Relative Spectral Sensitivity vs. Wavelength

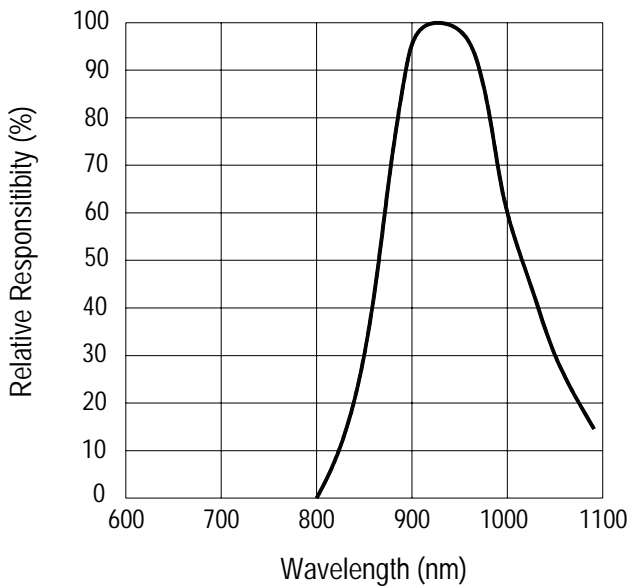

Fig.-2 Relative Transmission Distance vs. Direction

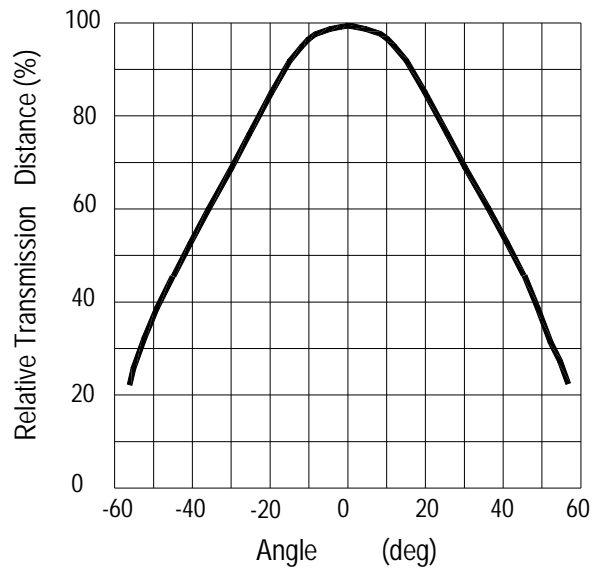

Fig.-3 Output Pulse Length vs. Arrival Distance

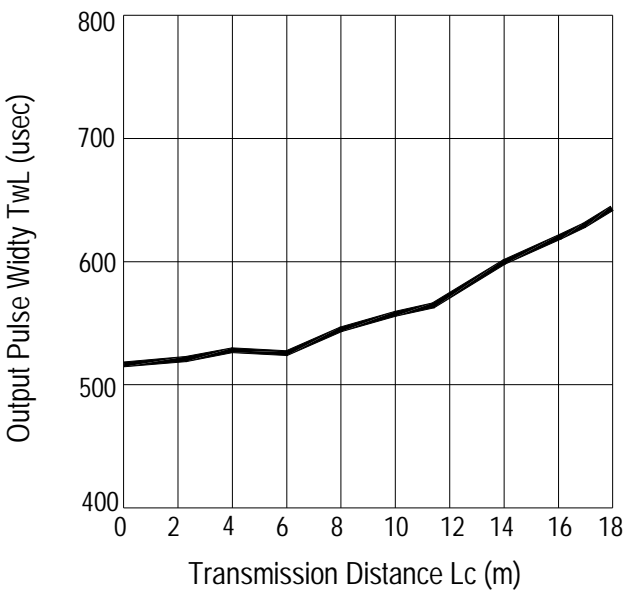
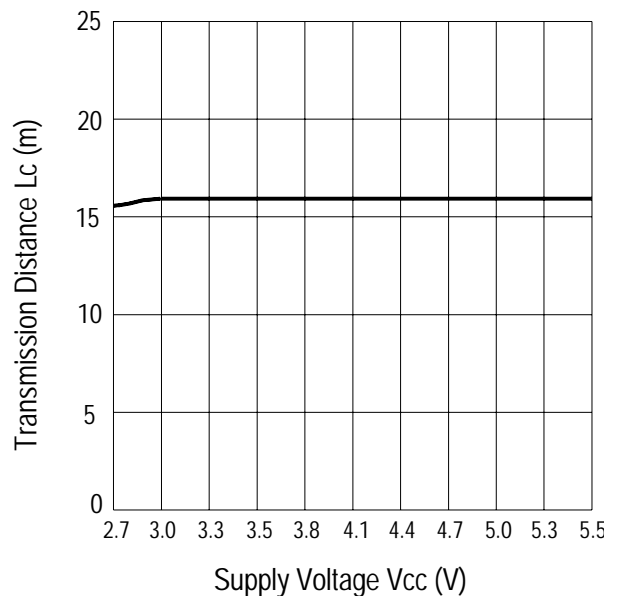

Fig.-4 Arrival Distance vs. Supply Voltage





# Infrared Remote Control Receiver Module

# IRM-36XXG Series

## Typical Electro-Optical Characteristics Curves

Fig.-5 Relative Transmission Distance vs. Center Carrier Frequency

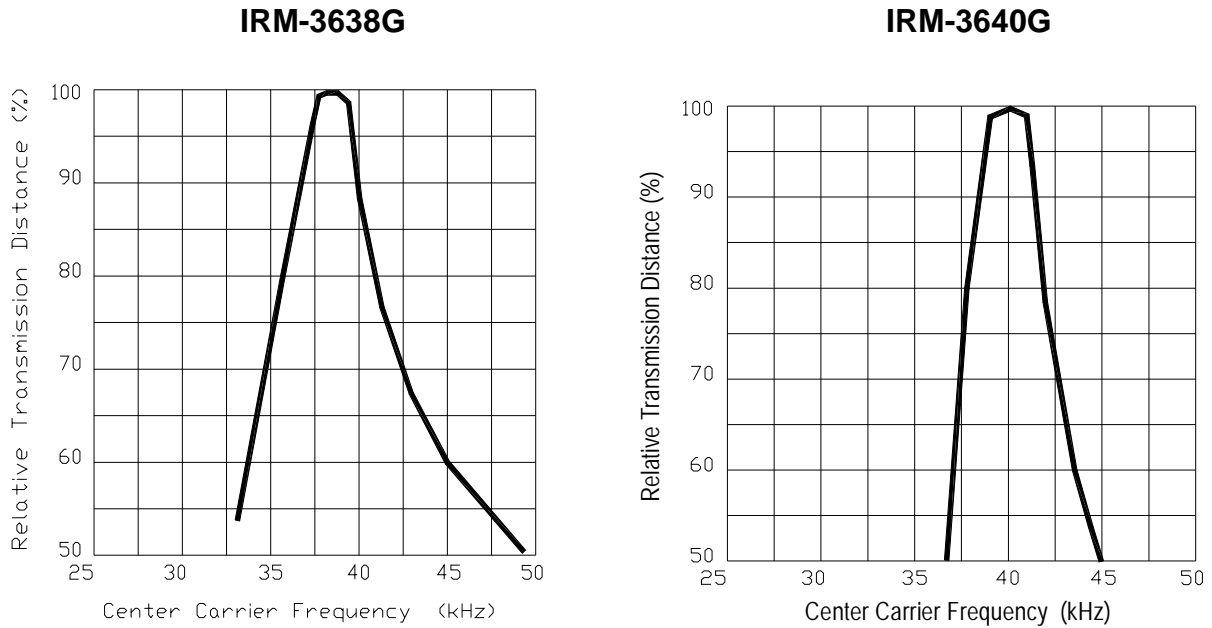
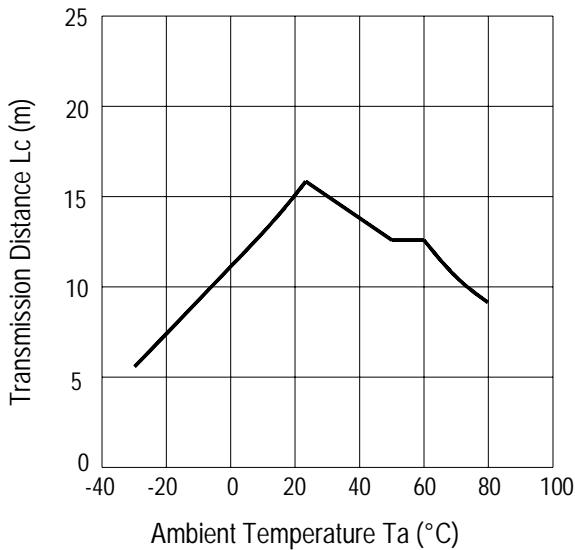

Fig.-6 Arrival Distance vs. Ambient Temperature



# Infrared Remote Control Receiver Module

## IRM-36XXG Series

### Reliability Test Item and Condition

The reliability of products shall be satisfied with items listed below.

Confidence level : 90%

LTPD : 10%

Test Items	Test Conditions	Failure Judgment Criteria	Samples(n) Defective(c)
Temperature cycle	1 cycle -40 $\longleftrightarrow$ +100 (15min)(5min)(15min) 300 cycle test	$L_0 \quad L \times 0.8$ $L_{45} \quad L \times 0.8$  L: Lower specification limit	n=22,c=0
High temperature test	Temp: +100 Vcc:6V 1000hrs		n=22,c=0
Low temperature storage	Temp: -40 1000hrs		n=22,c=0
High temperature High humidity	Ta: 85 ,RH:85% 1000hrs		n=22,c=0
Solder heat	Temp: 260±5 10sec 4mm From the bottom of the package.		n=22,c=0



# Infrared Remote Control Receiver Module

## IRM-36XXG Series

### ESD Precaution

Proper storage and handing procedures should be followed to prevent ESD damage to the devices especially when they are removed from the Anti-static bag. Electro-Static Sensitive Devices warning labels are on the packing.

### ESD Characteristics

Human Body Model	Machine Model	Spec.
All pin 2000V above	All pin 200V above	MIL-883C,Method 3015.7 HBM : 2000V MM: 200V

### Packing Quantity Specification

1. 1500PCS/1Box
2. 10Boxes/1Carton

### Label Form Specification

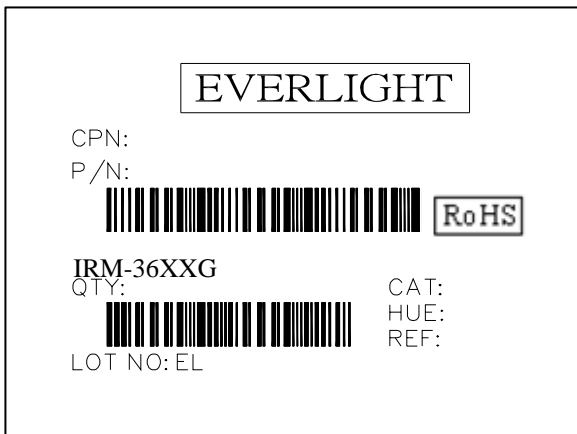

CPN: Customer's Production Number  
P/N: Production Number  
QTY: Packing Quantity  
CAT: Ranks  
HUE: Peak Wavelength  
REF: Reference  
LOT No: Lot Number  
MADE IN TAIWAN: Production Place



# Infrared Remote Control Receiver Module

## IRM-36XXG Series

---

### Notes

1. The specifications in this datasheet may be changed without notice. EVERLIGHT reserves the authority on material change for above specification.
2. When using this product, please observe the absolute maximum ratings and the instructions for use as outlined in this datasheet. EVERLIGHT assumes no responsibility for any damage resulting from use of the product which does not comply with the absolute maximum ratings and the instructions included in this datasheet.
3. These specification sheets include materials protected under copyright of EVERLIGHT. Reproduction in any form is prohibited without the specific consent of EVERLIGHT.

**EVERLIGHT ELECTRONICS CO., LTD.**

Office: No 25, Lane 76, Sec 3, Chung Yang Rd,  
Tucheng, Taipei 236, Taiwan, R.O.C

Tel: 886-2-2267-2000, 2267-9936

Fax: 886-2267-6244, 2267-6189, 2267-6306

<http://www.everlight.com>