

ADC202-12, ADC202-24

Automatic Door Controller for DC Motors

Features

- 2 versions - ADC202-12 (for 12V Motors) & ADC202-24 (for 24V Motors)
- Separate overload trigger levels for open and close.
- Selectable states: Auto-Close, PB/RC Open Only, Security Close, Photocell (contact / no contact)



ADC202-12	For 12V Motors
ADC202-24	For 24V Motors

Description

Automatic Doors in recent years have become part of our lives, we want shopping malls, restaurants, factories and even our homes to have Automatic Door Controllers installed.

The ADC202-12 is used for 12VDC motors while the ADC202-24 is used for 24VDC motors.

The ADC202 uses a special IC to control the automatic door. When the automatic door is opened or closed a limit switch is switched, which signals the IC to stop the door. If the Auto Close option is on, the door will automatically close after 30 seconds. The overload trigger level has a separate trimpot setting for opening (up) and closing (down), this enables the user to accurately set the overload sensitivity in each direction.

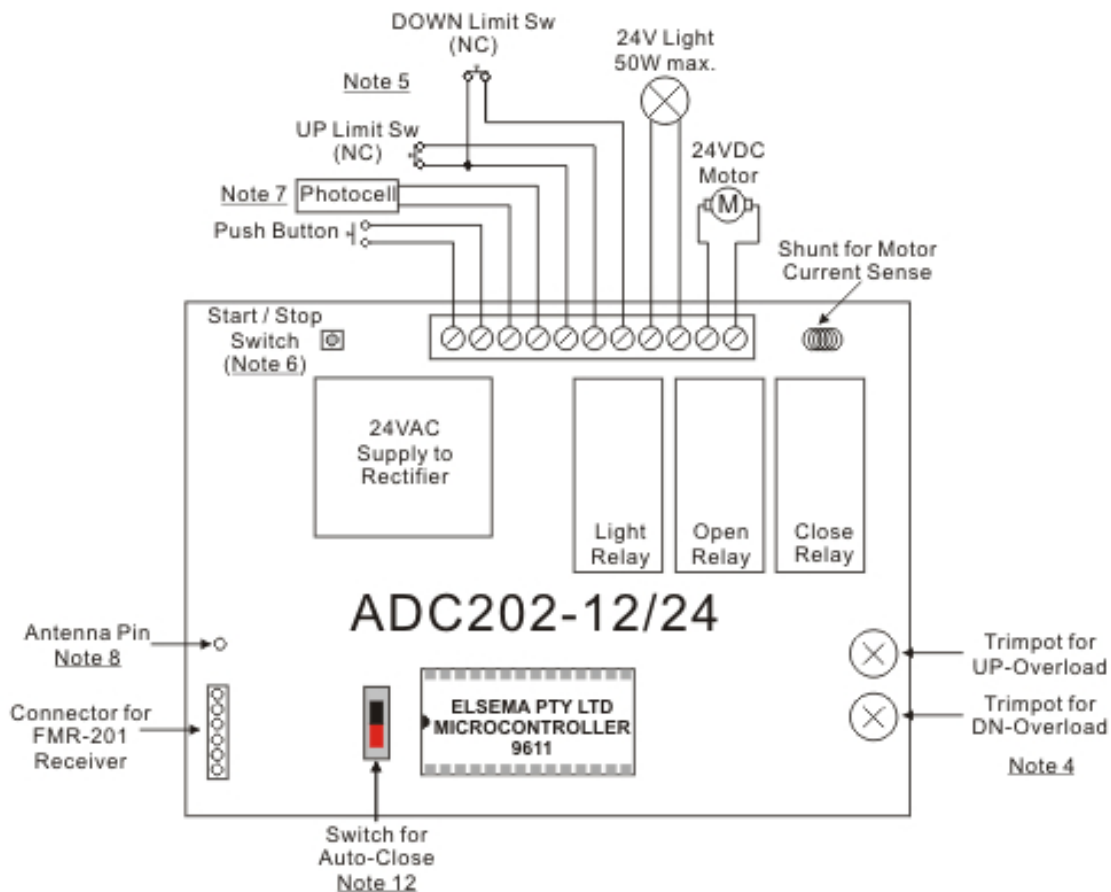

Technical & Installation Instruction

1. Power Supply: Use suitable 12 (ADC202-12) or 24 (ADC202-24) Volt 5 Amps transformer connected to the bridge rectifier.
2. We advise to install a 2amps fuse on the 240V AC side of the transformer.
3. “Open Relay” must open door, if wrong, reverse two wires to the motor.
4. Turning Clockwise on the overload trimpot will enable more motor power before tripping.
5. Up and Down limit switches are Normally Closed Contact (NC).
6. On-board push button may be used with a suitable linkage to any external button.
7. Photo Cell contact must be “normally closed” for operation.
8. Antenna wire to be approximately 1-2 metres wire, keep clear of other wires or metal frames.
9. Light relay has 24VDC output, operates for 3-minute courtesy light.
10. Size of printed circuit board is: 115 X 105 X 40mm.
11. Mounting Hole spacing is: 105 X 95mm. Use 1/8” or 3mm screws.
12. If Auto close switch is on, door will close after being open for 30 seconds.

Charging and battery backup Circuit

This diagram shows how to connect a battery and the BACH Elsema charger to the control card. This gives the added option of battery backup.

*BACH12 for 12 Volt Charging
 BACH24 for 24 Volt Charging

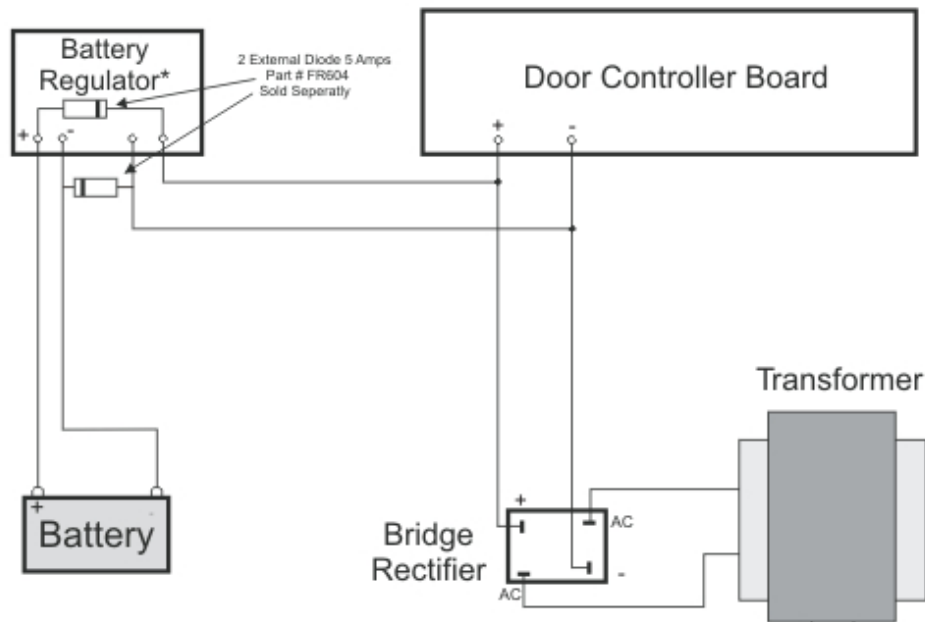

Elsema Pty Ltd
 3/10 Hume Rd, Smithfield
 NSW 2164
 Ph: 02 9609 4668
 Fax: 02 9725 2663
 Website: www.elsema.com

Distributed by: