



21150 PCI-to-PCI Bridge

Preliminary Datasheet

Product Features

- Complies fully with the *PCI Local Bus Specification, Revision 2.1*
- Complies fully with the *Advanced Configuration Power Interface (ACPI) Specification*
- Complies fully with the *PCI Power Management Specification, Revision 1.0*¹
- Complies fully with Revision 1.0 of the *PCI-to-PCI Bridge Architecture Specification*
- Implements delayed transactions for all PCI configuration, I/O, and memory read commands—up to three transactions simultaneously in each direction
- Allows 88 bytes of buffering (data and address) for posted memory write commands in each direction—up to five posted write transactions simultaneously in each direction
- Allows 72 bytes of read data buffering in each direction
- Provides concurrent primary and secondary bus operation, to isolate traffic
- Provides 10 secondary clock outputs with the following features:
 - Low skew permits direct drive of option slots
 - Individual clock disables, capable of automatic configuration during reset
- Provides arbitration support for nine secondary bus devices:
 - A programmable 2-level arbiter
 - Hardware disable control, to permit use of an external arbiter
- Provides a 4-pin general-purpose I/O interface, accessible through device-specific configuration space
- Provides enhanced address decoding:
 - A 32-bit I/O address range
 - A 32-bit memory-mapped I/O address range
 - A 64-bit prefetchable memory address range
 - ISA-aware mode for legacy support in the first 64KB of I/O address range
 - VGA addressing and VGA palette snooping support
- Includes live insertion support
- Supports PCI transaction forwarding for the following commands:
 - All I/O and memory commands
 - Type 1 to Type 1 configuration commands
 - Type 1 to Type 0 configuration commands (downstream only)
 - All Type 1 to special cycle configuration commands
- Includes downstream lock support
- Supports both 5-V and 3.3-V signaling environments
- Available in both 33 MHz and 66 MHz versions
- Provides an IEEE standard 1149.1 JTAG interface.

¹For 21150-AB and later revisions only. The 21150-AA does not implement this feature.

Notice: This document contains preliminary information on new products in production. The specifications are subject to change without notice. Verify with your local Intel sales office that you have the latest datasheet before finalizing a design.



Information in this document is provided in connection with Intel products. No license, express or implied, by estoppel or otherwise, to any intellectual property rights is granted by this document. Except as provided in Intel's Terms and Conditions of Sale for such products, Intel assumes no liability whatsoever, and Intel disclaims any express or implied warranty, relating to sale and/or use of Intel products including liability or warranties relating to fitness for a particular purpose, merchantability, or infringement of any patent, copyright or other intellectual property right. Intel products are not intended for use in medical, life saving, or life sustaining applications.

Intel may make changes to specifications and product descriptions at any time, without notice.

The 21150 PCI-to-PCI Bridge may contain design defects or errors known as errata which may cause the product to deviate from published specifications. Current characterized errata are available on request.

Contact your local Intel sales office or your distributor to obtain the latest specifications and before placing your product order.

Copies of documents which have an ordering number and are referenced in this document, or other Intel literature may be obtained by calling 1-800-548-4725 or by visiting Intel's website at <http://www.intel.com>.

Copyright © Intel Corporation, 1998

*Third-party brands and names are the property of their respective owners.

Contents

1.0	Introduction.....	1
1.1	Architecture	3
1.2	Data Path	5
1.3	Posted Write Queue	6
1.4	Delayed Transaction Queue.....	6
1.5	Read Data Queue	6
2.0	Signal Pins	7
2.1	Primary PCI Bus Interface Signals	8
2.2	Secondary PCI Bus Interface Signals	11
2.3	Secondary Bus Arbitration Signals.....	13
2.4	General-Purpose I/O Interface Signals	14
2.5	Clock Signals.....	14
2.6	Reset Signals	15
2.7	Miscellaneous Signals.....	16
2.8	JTAG Signals	17
3.0	Pin Assignments.....	19
3.1	Numeric Pin Assignment.....	20
3.2	Alphabetic Pin Assignment.....	24
4.0	PCI Bus Operation	27
4.1	Types of Transactions	27
4.2	Address Phase	28
4.2.1	Single Address Phase	28
4.2.2	Dual Address Phase.....	28
4.3	Device Select (DEVSEL#) Generation	29
4.4	Data Phase.....	29
4.5	Write Transactions	29
4.5.1	Posted Write Transactions	30
4.5.2	Memory Write and Invalidate Transactions	32
4.5.3	Delayed Write Transactions	32
4.5.4	Write Transaction Address Boundaries.....	34
4.5.5	Buffering Multiple Write Transactions.....	35
4.5.6	Fast Back-to-Back Write Transactions	35
4.6	Read Transactions	36
4.6.1	Prefetchable Read Transactions	37
4.6.2	Nonprefetchable Read Transactions.....	37
4.6.3	Read Prefetch Address Boundaries	38
4.6.4	Delayed Read Requests	38
4.6.5	Delayed Read Completion with Target.....	39
4.6.6	Delayed Read Completion on Initiator Bus	39
4.7	Configuration Transactions	42
4.7.1	Type 0 Access to the 21150.....	43
4.7.2	Type 1 to Type 0 Translation.....	44
4.7.3	Type 1 to Type 1 Forwarding	45
4.7.4	Special Cycles.....	46

4.8	Transaction Termination	47
4.8.1	Master Termination Initiated by the 21150	47
4.8.2	Master Abort Received by the 21150	48
4.8.3	Target Termination Received by the 21150	50
4.8.3.1	Delayed Write Target Termination Response	50
4.8.3.2	Posted Write Target Termination Response	51
4.8.3.3	Delayed Read Target Termination Response	51
4.8.4	Target Termination Initiated by the 21150	53
4.8.4.1	Target Retry	53
4.8.4.2	Target Disconnect	54
4.8.4.3	Target Abort	54
5.0	Address Decoding.....	55
5.1	Address Ranges.....	55
5.2	I/O Address Decoding	55
5.2.1	I/O Base and Limit Address Registers	56
5.2.2	ISA Mode	57
5.3	Memory Address Decoding.....	58
5.3.1	Memory-Mapped I/O Base and Limit Address Registers	59
5.3.2	Prefetchable Memory Base and Limit Address Registers	60
5.3.3	Prefetchable Memory 64-Bit Addressing Registers.....	61
5.4	VGA Support	62
5.4.1	VGA Mode.....	62
5.4.2	VGA Snoop Mode	63
6.0	Transaction Ordering	65
6.1	Transactions Governed by Ordering Rules.....	65
6.2	General Ordering Guidelines	66
6.3	Ordering Rules	66
6.4	Data Synchronization	68
7.0	Error Handling	69
7.1	Address Parity Errors	69
7.2	Data Parity Errors.....	70
7.2.1	Configuration Write Transactions to 21150 Configuration Space	70
7.2.2	Read Transactions	70
7.2.3	Delayed Write Transactions	71
7.2.4	Posted Write Transactions	73
7.3	Data Parity Error Reporting Summary	74
7.4	System Error (SERR#) Reporting	78
8.0	Exclusive Access	81
8.1	Concurrent Locks	81
8.2	Acquiring Exclusive Access Across the 21150	81
8.3	Ending Exclusive Access	82
9.0	PCI Bus Arbitration.....	85
9.1	Primary PCI Bus Arbitration	85
9.2	Secondary PCI Bus Arbitration	85
9.2.1	Secondary Bus Arbitration Using the Internal Arbiter.....	85
9.2.2	Secondary Bus Arbitration Using an External Arbiter.....	87

- 9.2.3 Bus Parking 87
- 10.0 General-Purpose I/O Interface 89
 - 10.1 gpio Control Registers 89
 - 10.2 Secondary Clock Control..... 90
 - 10.3 Live Insertion 92
- 11.0 Clocks..... 95
 - 11.1 Primary and Secondary Clock Inputs 95
 - 11.2 Secondary Clock Outputs..... 95
 - 11.3 Disabling Unused Secondary Clock Outputs 96
- 12.0 66-Mhz Operation..... 97
- 13.0 PCI Power Management 99
- 14.0 Reset..... 101
 - 14.1 Primary Interface Reset..... 101
 - 14.2 Secondary Interface Reset..... 101
 - 14.3 Chip Reset..... 102
- 15.0 Configuration Space Registers..... 103
 - 15.1 PCI-to-PCI Bridge Standard Configuration Registers 105
 - 15.1.1 Vendor ID Register—Offset 00h..... 105
 - 15.1.2 Device ID Register—Offset 02h 105
 - 15.1.3 Primary Command Register—Offset 04h 105
 - 15.1.4 Primary Status Register—Offset 06h 107
 - 15.1.5 Revision ID Register—Offset 08h 109
 - 15.1.6 Programming Interface Register—Offset 09h 109
 - 15.1.7 Subclass Code Register—Offset 0Ah 109
 - 15.1.8 Base Class Code Register—Offset 0Bh..... 109
 - 15.1.9 Cache Line Size Register—Offset 0Ch 110
 - 15.1.10 Primary Latency Timer Register—Offset 0Dh 110
 - 15.1.11 Header Type Register—Offset 0Eh..... 110
 - 15.1.12 Primary Bus Number Register—Offset 18h 111
 - 15.1.13 Secondary Bus Number Register—Offset 19h..... 111
 - 15.1.14 Subordinate Bus Number Register—Offset 1Ah 111
 - 15.1.15 Secondary Latency Timer Register—Offset 1Bh 112
 - 15.1.16 I/O Base Address Register—Offset 1Ch 112
 - 15.1.17 I/O Limit Address Register—Offset 1Dh..... 113
 - 15.1.18 Secondary Status Register—Offset 1Eh 113
 - 15.1.19 Memory Base Address Register—Offset 20h 115
 - 15.1.20 Memory Limit Address Register—Offset 22h 115
 - 15.1.21 Prefetchable Memory Base Address Register—Offset 24h 115
 - 15.1.22 Prefetchable Memory Limit Address Register—Offset 26h..... 116
 - 15.1.23 Prefetchable Memory Base Address Upper 32 Bits Register—
Offset 28h..... 116
 - 15.1.24 Prefetchable Memory Limit Address Upper 32 Bits Register—
Offset 2Ch 117
 - 15.1.25 I/O Base Address Upper 16 Bits Register—Offset 30h 117
 - 15.1.26 I/O Limit Address Upper 16 Bits Register—Offset 32h 118

	15.1.27 Subsystem Vendor ID Register—Offset 34h.....	118
	15.1.28 ECP Pointer Register—Offset 34h.....	118
	15.1.29 Subsystem ID Register—Offset 36h.....	119
	15.1.30 Interrupt Pin Register—Offset 3Dh.....	119
	15.1.31 Bridge Control Register—Offset 3Eh.....	119
	15.1.32 Capability ID Register—Offset DCh.....	122
	15.1.33 Next Item Ptr Register—Offset DDh.....	123
	15.1.34 Power Management Capabilities Register—Offset DEh.....	123
	15.1.35 Power Management Control and Status Register—Offset E0h.....	124
	15.1.36 PPB Support Extensions Registers—Offset E2h.....	124
	15.1.37 Data Register—Offset E3h.....	125
15.2	Device-Specific Configuration Registers.....	125
	15.2.1 Chip Control Register—Offset 40h.....	125
	15.2.2 Diagnostic Control Register—Offset 41h.....	126
	15.2.3 Arbiter Control Register—Offset 42h.....	127
	15.2.4 p_serr_l Event Disable Register—Offset 64h.....	128
	15.2.5 gpio Output Data Register—Offset 65h.....	129
	15.2.6 gpio Output Enable Control Register—Offset 66h.....	130
	15.2.7 gpio Input Data Register—Offset 67h.....	130
	15.2.8 Secondary Clock Control Register—Offset 68h.....	130
	15.2.9 p_serr_l Status Register—Offset 6Ah.....	132
15.3	Configuration Register Values After Reset.....	133
16.0	JTAG Test Port.....	135
	16.1 Overview.....	135
	16.2 JTAG Signal Pins.....	135
	16.3 Test Access Port Controller.....	135
	16.4 Instruction Register.....	136
	16.5 Bypass Register.....	136
	16.6 Boundary-Scan Register.....	136
	16.6.1 Boundary-Scan Register Cells.....	137
	16.6.2 21150 Boundary-Scan Order.....	137
	16.7 Initialization.....	141
17.0	Electrical Specifications.....	143
	17.1 PCI Electrical Specification Conformance.....	143
	17.2 Absolute Maximum Ratings.....	143
	17.3 DC Specifications.....	144
	17.4 AC Timing Specifications.....	144
	17.4.1 Clock Timing Specifications.....	145
	17.4.2 PCI Signal Timing Specifications.....	146
	17.4.3 Reset Timing Specifications.....	148
	17.4.4 gpio Timing Specifications.....	149
	17.4.5 JTAG Timing Specifications.....	150
18.0	Mechanical Specifications.....	153

Figures

1	21150 on the System Board.....	2
2	21150 with Option Cards.....	3
3	21150 on the System Board.....	4
4	21150 Downstream Data Path.....	5
5	21150 Pin Assignment.....	19
6	Flow-Through Posted Memory Write Transaction.....	31
7	Downstream Delayed Write Transaction.....	34
8	Multiple Memory Write Transactions Posted and Initiated as Fast	
	Back-to-Back Transactions on the Target Bus.....	36
9	Nonprefetchable Delayed Read Transaction.....	40
10	Prefetchable Delayed Read Transaction.....	41
11	Flow-Through Prefetchable Read Transaction.....	42
12	Configuration Transaction Address Formats.....	43
13	Delayed Write Transaction Terminated with Master Abort.....	49
14	Delayed Read Transaction Terminated with Target Abort.....	52
15	I/O Transaction Forwarding Using Base and Limit Addresses.....	56
16	I/O Transaction Forwarding in ISA Mode.....	58
17	Memory Transaction Forwarding Using Base and Limit Registers.....	60
18	Secondary Arbiter Example.....	86
19	Example of gpio Clock Mask Implementation on the System Board.....	91
20	Clock Mask Load and Shift Timing.....	92
21	p_clk and s_clk Relative Timing.....	95
22	21150 Configuration Space.....	104
23	PCI Clock Signal AC Parameter Measurements.....	145
24	PCI Signal Timing Measurement Conditions.....	147
25	208-Pin PQFP Package.....	153

Tables

1	21150 Functional Blocks.....	4
2	Signal Pins.....	7
3	Signal Types.....	7
4	Primary PCI Bus Interface Signals.....	8
5	Secondary PCI Bus Interface Signals.....	11
6	Secondary PCI Bus Interface Signals.....	13
7	General-Purpose I/O Interface Signals.....	14
8	Clock Signals.....	14
9	Reset Signals.....	15
10	Miscellaneous Signals.....	16
11	JTAG Signals.....	17
12	Signal Types.....	20
13	Numeric Pin Assignments.....	21
14	Alphabetic Pin Assignments.....	24
15	21150 PCI Transactions.....	27
16	Write Transaction Forwarding.....	29
17	Write Transaction Disconnect Address Boundaries.....	35
18	Read Transaction Prefetching.....	36
19	Read Prefetch Address Boundaries.....	38

20	Device Number to IDSEL s_ad Pin Mapping	45
21	21150 Response to Delayed Write Target Termination	50
22	21150 Response to Posted Write Target Termination	51
23	21150 Response to Delayed Read Target Termination	51
24	Summary of Transaction Ordering	66
25	Setting the Primary Interface Detected Parity Error Bit	74
26	Setting the Secondary Interface Detected Parity Error Bit	75
27	Setting the Primary Interface Data Parity Detected Bit	75
28	Setting the Secondary Interface Data Parity Detected Bit	76
29	Assertion of p_perr_l	76
30	Assertion of s_perr_l	77
31	Assertion of p_serr_l for Data Parity Errors	78
32	gpio Operation	90
33	gpio Serial Data Format	90
34	Power Management Transitions	99
35	Configuration Register Values After Reset	133
36	JTAG Pins	135
37	JTAG Instruction Registers	136
38	Boundary-Scan Order	137
39	Absolute Maximum Ratings	143
40	Functional Operating Range	143
41	DC Parameters	144
42	33 MHz PCI Clock Signal AC Parameters	145
43	66 MHz PCI Clock Signal AC Parameters	146
44	33 MHz PCI Signal Timing	147
45	66 MHz PCI Signal Timing	148
46	Reset Timing Specifications	148
47	33 MHz gpio Timing Specifications	149
48	66 MHz gpio Timing Specifications	150
49	JTAG Timing Specifications	150
50	208-Pin PQFP Package Dimensions	154

1.0 Introduction

The 21150 is a second-generation PCI-to-PCI bridge and is fully compliant with *PCI Local Bus Specification, Revision 2.1*. The 21150 provides full support for delayed transactions, which enables the buffering of memory read, I/O, and configuration transactions. The 21150 has separate posted write, read data, and delayed transaction queues with significantly more buffering capability than first-generation bridges. In addition, the 21150 supports buffering of simultaneous multiple posted write and delayed transactions in both directions. Among the features provided by the 21150 are a programmable 2-level secondary bus arbiter, an IEEE standard 1149.1 JTAG interface, live insertion support, a 4-pin general-purpose I/O interface, individual secondary clock disables, and enhanced address decoding. The 21150 has sufficient clock and arbitration pins to support nine PCI bus master devices directly on its secondary interface.

The 21150 allows the two PCI buses to operate concurrently. This means that a master and a target on the same PCI bus can communicate while the other PCI bus is busy. This traffic isolation may increase system performance in applications such as multimedia.

The 21150 makes it possible to extend a system's load capability limit beyond that of a single PCI bus by allowing motherboard designers to add more PCI devices or more PCI option card slots than a single PCI bus can support. [Figure 1](#) illustrates the use of two 21150 PCI-to-PCI bridges on a system board. Each 21150 that is added to the board creates a new PCI bus that provides support for the additional PCI slots or devices

Option card designers can use the 21150 to implement multiple-device PCI option cards. Without a PCI-to-PCI bridge, PCI loading rules would limit option cards to one device. The PCI Local Bus Specification) loading rules limit PCI option cards to a single connection per PCI signal in the option card connector. The 21150 overcomes this restriction by providing, on the option card, an independent PCI bus to which up to nine devices can be attached. [Figure 2](#) shows how the 21150 enables the design of a multicomponent option card.

Figure 1. 21150 on the System Board

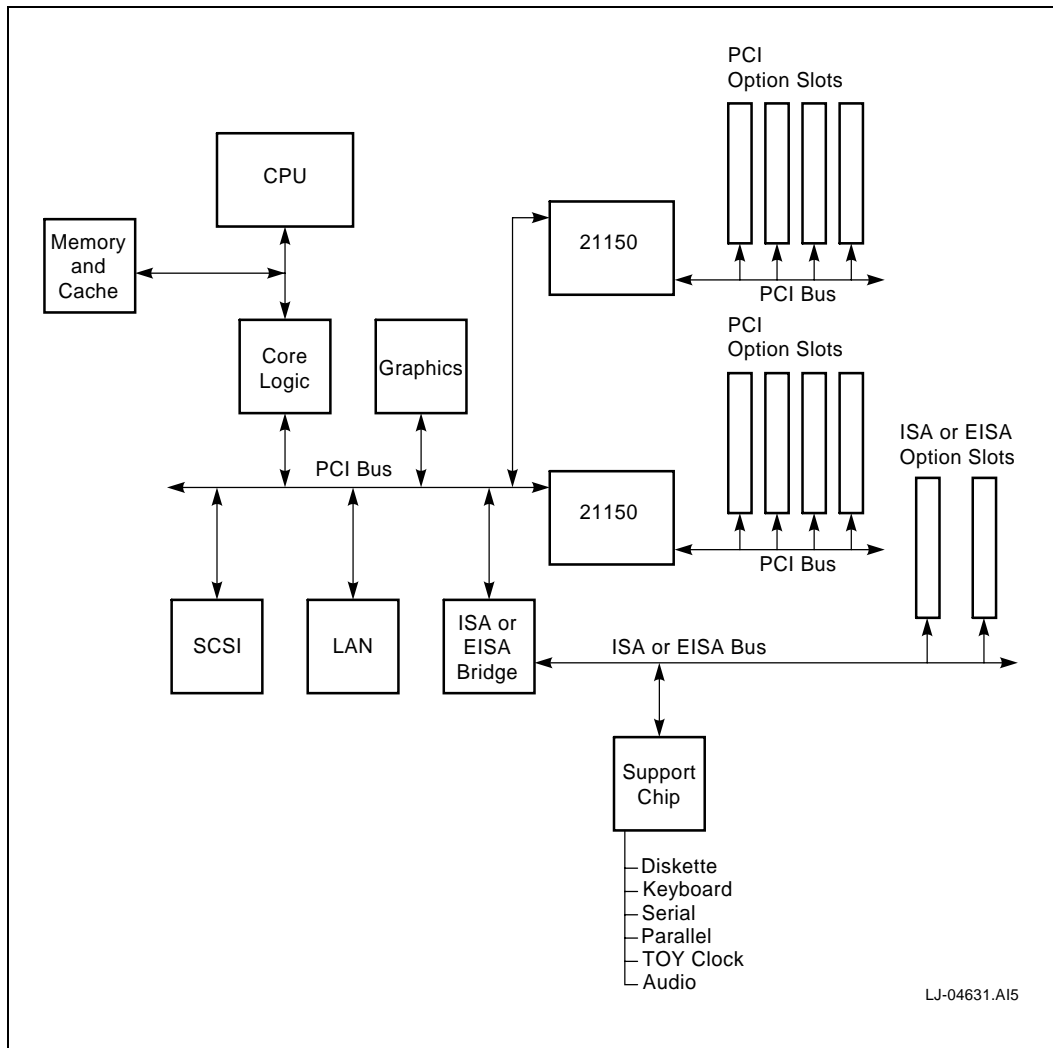

LJ-04631.AI5

Figure 2. 21150 with Option Cards

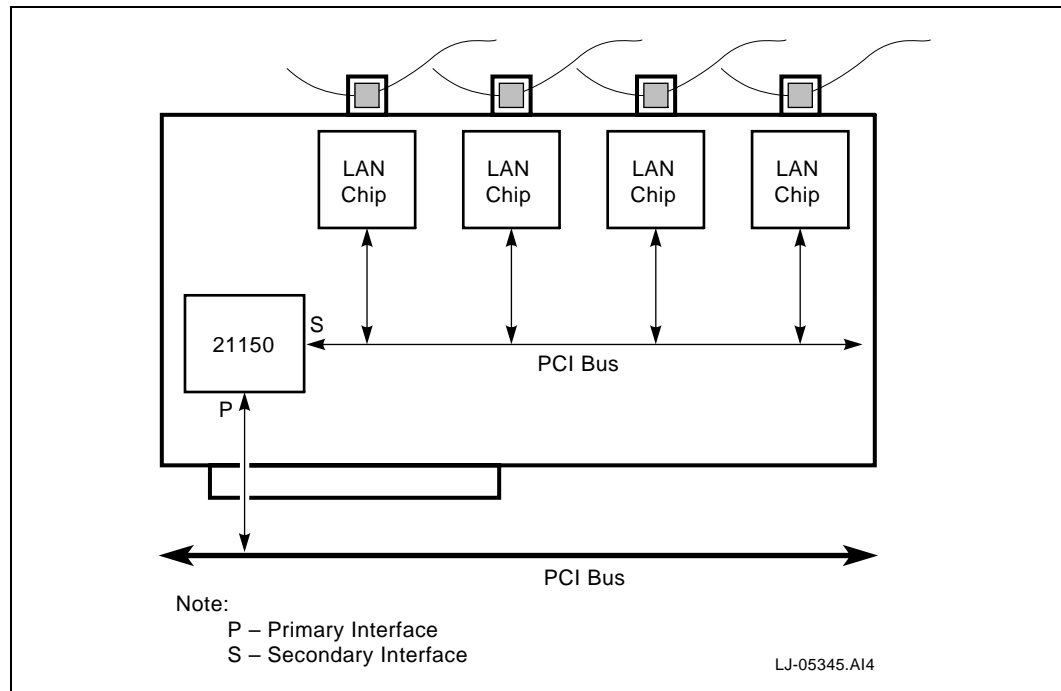

1.1 Architecture

The 21150 internal architecture consists of the following major functions:

- PCI interface control logic for the primary and secondary PCI interfaces
- Data path and data path control logic
- Configuration register and configuration control logic
- Secondary bus arbiter

Figure 3 shows the major functional blocks of the 21150, and Table 1 describes these blocks.

Figure 3. 21150 on the System Board

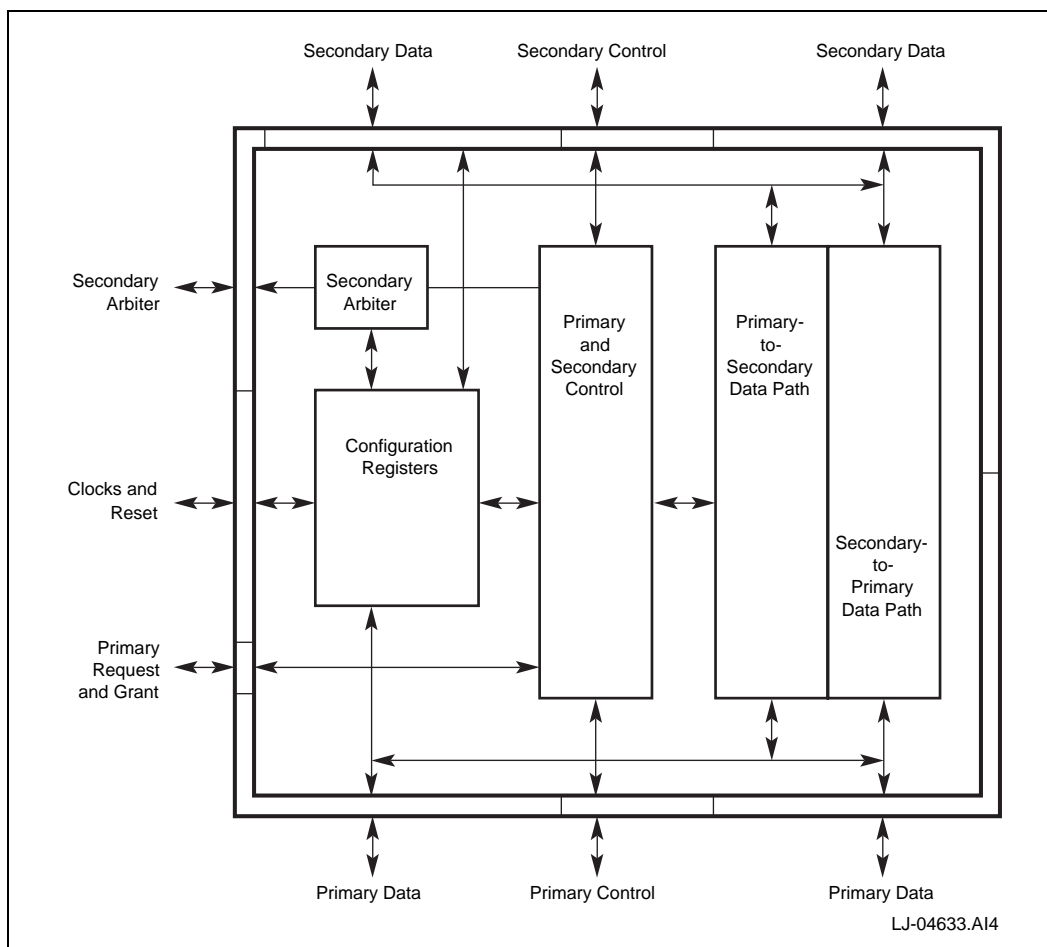

Table 1. 21150 Functional Blocks (Sheet 1 of 2)

Function Blocks	Description
Primary and Secondary Control	PCI interface control logic. This block contains state machines and control logic for the primary target interface, the primary master interface, the secondary target interface, and the secondary master interface. This block also contains logic that interfaces to the data path and the configuration block
Primary-to-Secondary Data Path	Data path for data received on the primary interface and driven on the secondary interface. This block is used for write transactions initiated on the primary PCI bus and for returning read data for read transactions initiated on the secondary PCI bus. This block contains logic to store and, for posted write transactions, to increment the address of the current transaction. This block also performs bus command and configuration address format translations.

Table 1. 21150 Functional Blocks (Sheet 2 of 2)

Secondary-to-Primary Data Path	Data path for data received on the secondary interface and driven on the primary interface. This block is used for write transactions initiated on the secondary PCI bus and for returning read data for read transactions initiated on the primary PCI bus. This block contains logic to store and, for posted write transactions, to increment the address of the current transaction. This block also performs bus command and configuration address format translations
Configuration Registers	Configuration space registers and corresponding control logic. These registers are accessible from the primary interface only.
Secondary Bus Arbiter Control	Logic for secondary bus arbitration. This block receives s_req_l<8:0>, as well as the 21150 secondary bus request, and drives one of the s_gnt_l<8:0> lines or the 21150 secondary bus grant.

1.2 Data Path

The data path consists of a primary-to-secondary data path for transactions and data flowing in the downstream direction and a secondary-to-primary data path for transactions and data flowing in the upstream direction.

Both data paths have the following queues:

- Posted write queue
- Delayed transaction queue
- Read data queue

To prevent deadlocks and to maintain data coherency, a set of ordering rules is imposed on the forwarding of posted and delayed transactions across the 21150. The queue structure, along with the order in which the transactions in the queues are initiated and completed, supports these ordering requirements. [Section 6.0](#) describes the 21150 ordering rules in detail.

See [Section 4.0](#) for a detailed description of 21150 PCI bus operation.

[Figure 4](#) shows the 21150 data path for the downstream direction, and the following sections describe the data path queues.

Figure 4. 21150 Downstream Data Path

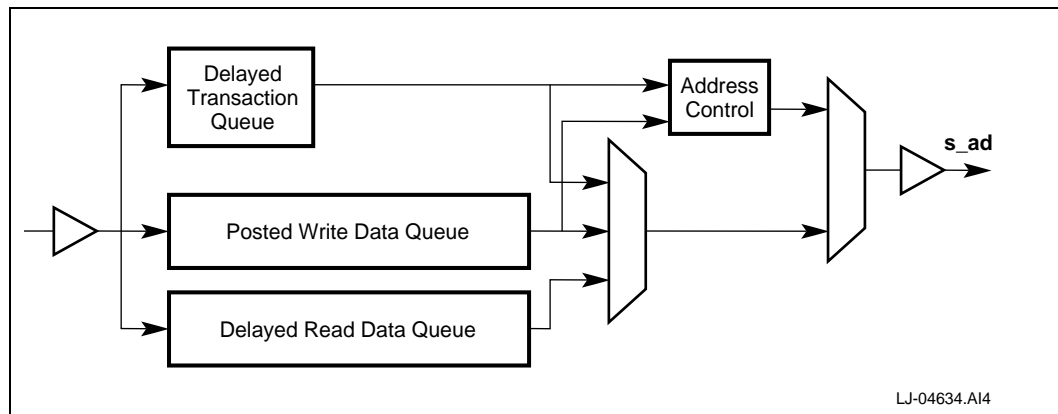

1.3 Posted Write Queue

The posted write queue contains the address and data of memory write transactions targeted for the opposite interface. The posted write transaction can consist of an arbitrary number of data phases, subject to the amount of space in the queue and disconnect boundaries. The posted write queue can contain multiple posted write transactions. The number of posted write transactions that can be queued at one time is dependent upon their burst size. The posted write queue consists of 88 bytes in each direction.

1.4 Delayed Transaction Queue

For a delayed write request transaction, the delayed transaction queue contains the address, bus command, 1 Dword of write data, byte enable bits, and parity. When the delayed write transaction is completed on the target bus, the write completion status is added to the corresponding entry.

For a delayed read request transaction, the delayed transaction queue contains the address and bus command, and for nonprefetchable read transactions, the byte enable bits. When the delayed read transaction is completed on the target bus, the read completion status corresponding to that transaction is added to the delayed request entry. Read data is placed in the read data queue.

The delayed transaction queue can hold up to three transactions (any combination of read and write transactions).

1.5 Read Data Queue

The read data queue contains read data transferred from the target during a delayed read completion. Read data travels in the opposite direction of the transaction. The primary-to-secondary read data queue contains read data corresponding to a delayed read transaction residing in the secondary-to-primary delayed transaction queue. The secondary-to-primary read data queue contains read data corresponding to a delayed read transaction in the primary-to-secondary delayed transaction queue. The amount of read data per transaction depends on the amount of space in the queue and disconnect boundaries.

Read data for up to three transactions, subject to the burst size of the read transactions and available queue space, can be stored. The read data queue for the 21150 consists of 72 bytes in each direction.

2.0 Signal Pins

This chapter provides detailed descriptions of the 21150 signal pins, grouped by function.

Table 2 describes the signal pin functional groups, and the following sections describe the signals in each group.

Table 2. Signal Pins

Function	Description
Primary PCI bus interface signal pins	All PCI pins required by the Revision 1.1 of the <i>PCI-to-PCI Bridge Architecture Specification</i> .
Secondary PCI bus interface signal pins	All PCI pins required by the Revision 1.1 of the <i>PCI-to-PCI Bridge Architecture Specification</i> .
Secondary PCI bus arbiter signal pins	Nine request/grant pairs of pins for the secondary PCI bus. An arbiter enable control pin.
General-purpose I/O interface signal pins	Four general-purpose pins.
Clock signal pins	Two clock inputs (one for each PCI interface). Ten clock outputs (for nine external secondary PCI bus devices and also for the 21150).
Reset signal pins	A primary interface reset input. A secondary interface reset output.
Miscellaneous signal pins	An input-only pin used to disable secondary clock outputs. Two input voltage signaling level pins. Three pins controlling 66 MHz operation.
JTAG signal pins	All JTAG pins required by IEEE standard 1149.1.

Table 3 defines the signal type abbreviations used in the signal tables:

Table 3. Signal Types

Signal Type	Description
I	Standard input only.
O	Standard output only.
TS	Tristate bidirectional.
STS	Sustained tristate. Active low signal must be pulled high for one cycle when deasserting.
OD	Standard open drain.

Note: The *_l* signal name suffix indicates that the signal is asserted when it is at a low voltage level and corresponds to the *#* suffix in the *PCI Local Bus Specification*. If this suffix is not present, the signal is asserted when it is at a high voltage level.

2.1 Primary PCI Bus Interface Signals

Table 4 describes the primary PCI bus interface signals.

Table 4. Primary PCI Bus Interface Signals (Sheet 1 of 3)

Signal Name	Type	Description
p_ad<31:0>	TS	Primary PCI interface address/data. These signals are a multiplexed address and data bus. During the address phase or phases of a transaction, the initiator drives a physical address on p_ad<31:0>. During the data phases of a transaction, the initiator drives write data, or the target drives read data, on p_ad<31:0>. When the primary PCI bus is idle, the 21150 drives p_ad to a valid logic level when p_gnt_l is asserted.
p_cbe_l<3:0>	TS	Primary PCI interface command/byte enables. These signals are a multiplexed command field and byte enable field. During the address phase or phases of a transaction, the initiator drives the transaction type on p_cbe_l<3:0>. When there are two address phases, the first address phase carries the dual address command and the second address phase carries the transaction type. For both read and write transactions, the initiator drives byte enables on p_cbe_l<3:0> during the data phases. When the primary PCI bus is idle, the 21150 drives p_cbe_l to a valid logic level when p_gnt_l is asserted.
p_par	TS	Primary PCI interface parity. Signal p_par carries the even parity of the 36 bits of p_ad<31:0> and p_cbe_l<3:0> for both address and data phases. Signal p_par is driven by the same agent that has driven the address (for address parity) or the data (for data parity). Signal p_par contains valid parity one cycle after the address is valid (indicated by assertion of p_frame_l, or one cycle after data is valid (indicated by assertion of p_irdy_l for write transactions and p_trdy_l for read transactions). Signal p_par is driven by the device driving read or write data one cycle after p_ad is driven. Signal p_par is tristated one cycle after the p_ad lines are tristated. Devices receiving data sample p_par as an input to check for possible parity errors. When the primary PCI bus is idle, the 21150 drives p_par to a valid logic level when p_gnt_l is asserted (one cycle after the p_ad bus is parked).
p_frame_l	STS	Primary PCI interface FRAME#. Signal p_frame_l is driven by the initiator of a transaction to indicate the beginning and duration of an access on the primary PCI bus. Signal p_frame_l assertion (falling edge) indicates the beginning of a PCI transaction. While p_frame_l remains asserted, data transfers can continue. The deassertion of p_frame_l indicates the final data phase requested by the initiator. When the primary PCI bus is idle, p_frame_l is driven to a deasserted state for one cycle and then is sustained by an external pull-up resistor.
p_irdy_l	STS	Primary PCI interface IRDY#. Signal p_irdy_l is driven by the initiator of a transaction to indicate the initiator's ability to complete the current data phase on the primary PCI bus. During a write transaction, assertion of p_irdy_l indicates that valid write data is being driven on the p_ad bus. During a read transaction, assertion of p_irdy_l indicates that the initiator is able to accept read data for the current data phase. Once asserted during a given data phase, p_irdy_l is not deasserted until the data phase completes. When the primary bus is idle, p_irdy_l is driven to a deasserted state for one cycle and then is sustained by an external pull-up resistor.

Table 4. Primary PCI Bus Interface Signals (Sheet 2 of 3)

Signal Name	Type	Description
p_trdy_l	STS	Primary PCI interface TRDY#. Signal p_trdy_l is driven by the target of a transaction to indicate the target's ability to complete the current data phase on the primary PCI bus. During a write transaction, assertion of p_trdy_l indicates that the target is able to accept write data for the current data phase. During a read transaction, assertion of p_trdy_l indicates that the target is driving valid read data on the p_ad bus. Once asserted during a given data phase, p_trdy_l is not deasserted until the data phase completes. When the primary bus is idle, p_trdy_l is driven to a deasserted state for one cycle and then is sustained by an external pull-up resistor.
p_devsel_l	STS	Primary PCI interface DEVSEL#. p_devsel_l is asserted by the target, indicating that the device is accepting the transaction. As a target, the 21150 performs positive decoding on the address of a transaction initiated on the primary bus to determine whether to assert p_devsel_l. As an initiator of a transaction on the primary bus, the 21150 looks for the assertion of p_devsel_l within five cycles of p_frame_l assertion; otherwise, the 21150 terminates the transaction with a master abort. When the primary bus is idle, p_devsel_l is driven to a deasserted state for one cycle and then is sustained by an external pull-up resistor.
p_stop_l	STS	Primary PCI interface STOP#. Signal p_stop_l is driven by the target of the current transaction, indicating that the target is requesting the initiator to stop the current transaction on the primary bus. <ul style="list-style-type: none"> When p_stop_l is asserted in conjunction with p_trdy_l and p_devsel_l assertion, a disconnect with data transfer is being signaled. When p_stop_l and p_devsel_l are asserted, but p_trdy_l is deasserted, a target disconnect without data transfer is being signaled. When this occurs on the first data phase, that is, no data is transferred during the transaction, this is referred to as a target retry. When p_stop_l is asserted and p_devsel_l is deasserted, the target is signaling a target abort. When the primary bus is idle, p_stop_l is driven to a deasserted state for one cycle and then is sustained by an external pull-up resistor.
p_lock_l	I	Primary PCI interface LOCK#. Signal p_lock_l is deasserted during the first address phase of a transaction and is asserted one clock cycle later by an initiator attempting to perform an atomic operation that may take more than one PCI transaction to complete. The 21150 samples p_lock_l as a target and can propagate the lock across to the secondary bus. The 21150 does not drive p_lock_l as an initiator; that is, the 21150 does not propagate locked transactions upstream. When released by an initiator, p_lock_l is driven to a deasserted state for one cycle and then is sustained by an external pull-up resistor.
p_idsel	I	Primary PCI interface IDSEL#. Signal p_idsel is used as the chip select line for Type 0 configuration accesses to 21150 configuration space. When p_idsel is asserted during the address phase of a Type 0 configuration transaction, the 21150 responds to the transaction by asserting p_devsel_l.

Table 4. Primary PCI Bus Interface Signals (Sheet 3 of 3)

Signal Name	Type	Description
p_perr_l	STS	Primary PCI interface PERR#. Signal p_perr_l is asserted when a data parity error is detected for data received on the primary interface. The timing of p_perr_l corresponds to p_par driven one cycle earlier and p_ad and p_cbe_l driven two cycles earlier. Signal p_perr_l is asserted by the target during write transactions, and by the initiator during read transactions. When the primary bus is idle, p_perr_l is driven to a deasserted state for one cycle and then is sustained by an external pull-up resistor.
p_serr_l	OD	Primary PCI interface SERR#. Signal p_serr_l can be driven low by any device on the primary bus to indicate a system error condition. The 21150 can assert p_serr_l for the following reasons: <ul style="list-style-type: none"> • Address parity error • Posted write data parity error on target bus • Secondary bus s_serr_l assertion • Master abort during posted write transaction • Target abort during posted write transaction • Posted write transaction discarded • Delayed write request discarded • Delayed read request discarded • Delayed transaction master timeout Signal p_serr_l is pulled up through an external resistor.
p_req_l	TS	Primary PCI bus REQ#. Signal p_req_l is asserted by the 21150 to indicate to the primary bus arbiter that it wants to start a transaction on the primary bus. When the 21150 receives a target retry or disconnect in response to initiating a transaction, the 21150 deasserts p_req_l for at least two PCI clock cycles before asserting it again.
p_gnt_l	I	Primary PCI bus GNT#. When asserted, p_gnt_l indicates to the 21150 that access to the primary bus is granted. The 21150 can start a transaction on the primary bus when the bus is idle and p_gnt_l is asserted. When the 21150 has not requested use of the bus and p_gnt_l is asserted, the 21150 must drive p_ad, and p_par to valid logic levels.

2.2 Secondary PCI Bus Interface Signals

Table 5 describes the secondary PCI bus interface signals.

Table 5. Secondary PCI Bus Interface Signals (Sheet 1 of 3)

Signal Name	Type	Description
s_ad<31:0>	TS	Secondary PCI interface address/data. These signals are a multiplexed address and data bus. During the address phase or phases of a transaction, the initiator drives a physical address on s_ad<31:0>. During the data phases of a transaction, the initiator drives write data, or the target drives read data, on s_ad<31:0>. When the secondary PCI bus is idle, the 21150 drives s_ad to a valid logic level when its secondary bus grant is asserted.
s_cbe_l<3:0>	TS	Secondary PCI interface command/byte enables. These signals are a multiplexed command field and byte enable field. During the address phase or phases of a transaction, the initiator drives the transaction type on s_cbe_l<3:0>. When there are two address phases, the first address phase carries the dual address command and the second address phase carries the transaction type. For both read and write transactions, the initiator drives byte enables on s_cbe_l<3:0> during the data phases. When the secondary PCI bus is idle, the 21150 drives s_cbe_l to a valid logic level when its secondary bus grant is asserted.
s_par	TS	Secondary PCI interface parity. Signal s_par carries the even parity of the 36 bits of s_ad<31:0> and s_cbe_l<3:0> for both address and data phases. Signal s_par is driven by the same agent that has driven the address (for address parity) or the data (for data parity). Signal s_par contains valid parity one cycle after the address is valid (indicated by assertion of s_frame_l), or one cycle after data is valid (indicated by assertion of s_irdy_l for write transactions and s_trdy_l for read transactions). Signal s_par is driven by the device driving read or write data one cycle after s_ad is driven. Signal s_par is tristated one cycle after the s_ad lines are tristated. Devices receiving data sample s_par as an input in order to check for possible parity errors. When the secondary PCI bus is idle, the 21150 drives s_par to a valid logic level when its secondary bus grant is asserted (one cycle after the s_ad bus is parked).
s_frame_l	STS	Secondary PCI interface FRAME#. Signal s_frame_l is driven by the initiator of a transaction to indicate the beginning and duration of an access on the secondary PCI bus. Signal s_frame_l assertion (falling edge) indicates the beginning of a PCI transaction. While s_frame_l remains asserted, data transfers can continue. The deassertion of s_frame_l indicates the final data phase requested by the initiator. When the secondary PCI bus is idle, s_frame_l is driven to a deasserted state for one cycle and then is sustained by an external pull-up resistor.

Table 5. Secondary PCI Bus Interface Signals (Sheet 2 of 3)

Signal Name	Type	Description
s_irdy_l	STS	Secondary PCI interface IRDY#. Signal s_irdy_l is driven by the initiator of a transaction to indicate the initiator's ability to complete the current data phase on the secondary PCI bus. During a write transaction, assertion of s_irdy_l indicates that valid write data is being driven on the s_ad bus. During a read transaction, assertion of s_irdy_l indicates that the initiator is able to accept read data for the current data phase. Once asserted during a given data phase, s_irdy_l is not deasserted until the data phase completes. When the secondary bus is idle, s_irdy_l is driven to a deasserted state for one cycle and then is sustained by an external pull-up resistor.
s_trdy_l	STS	Secondary PCI interface TRDY. Signal s_trdy_l is driven by the target of a transaction to indicate the target's ability to complete the current data phase on the secondary PCI bus. During a write transaction, assertion of s_trdy_l indicates that the target is able to accept write data for the current data phase. During a read transaction, assertion of s_trdy_l indicates that the target is driving valid read data on the s_ad bus. Once asserted during a given data phase, s_trdy_l is not deasserted until the data phase completes. When the secondary bus is idle, s_trdy_l is driven to a deasserted state for one cycle and then is sustained by an external pull-up resistor.
s_devsel_l	STS	Secondary PCI interface DEVSEL#. Signal s_devsel_l is asserted by the target, indicating that the device is accepting the transaction. As a target, the 21150 performs positive decoding on the address of a transaction initiated on the secondary bus in order to determine whether to assert s_devsel_l. As an initiator of a transaction on the secondary bus, the 21150 looks for the assertion of s_devsel_l within five cycles of s_frame_l assertion; otherwise, the 21150 terminates the transaction with a master abort. When the secondary bus is idle, s_devsel_l is driven to a deasserted state for one cycle and then is sustained by an external pull-up resistor.
s_stop_l	STS	Secondary PCI interface STOP#. Signal s_stop_l is driven by the target of the current transaction, indicating that the target is requesting the initiator to stop the current transaction on the secondary bus. <ul style="list-style-type: none"> When s_stop_l is asserted in conjunction with s_trdy_l and s_devsel_l assertion, a disconnect with data transfer is being signaled. When s_stop_l and s_devsel_l are asserted, but s_trdy_l is deasserted, a target disconnect without data transfer is being signaled. When this occurs on the first data phase, that is, no data is transferred during the transaction, this is referred to as a target retry. When s_stop_l is asserted and s_devsel_l is deasserted, the target is signaling a target abort. When the secondary bus is idle, s_stop_l is driven to a deasserted state for one cycle and then is sustained by an external pull-up resistor.

Table 5. Secondary PCI Bus Interface Signals (Sheet 3 of 3)

Signal Name	Type	Description
s_lock_l	STS	Secondary PCI interface LOCK#. Signal s_lock_l is deasserted during the first address phase of a transaction and is asserted one clock cycle later by the 21150 when it is propagating a locked transaction downstream. The 21150 does not propagate locked transactions upstream. The 21150 continues to assert s_lock_l until the address phase of the next locked transaction, or until the lock is released. When the lock is released, s_lock_l is driven to a deasserted state for one cycle and then is sustained by an external pull-up resistor.
s_perr_l	STS	Secondary PCI interface PERR#. Signal s_perr_l is asserted when a data parity error is detected for data received on the secondary interface. The timing of s_perr_l corresponds to s_par driven one cycle earlier and s_ad driven two cycles earlier. Signal s_perr_l is asserted by the target during write transactions, and by the initiator during read transactions. When the secondary bus is idle, s_perr_l is driven to a deasserted state for one cycle and then is sustained by an external pull-up resistor.
s_serr_l	I	Secondary PCI interface SERR#. Signal s_serr_l can be driven low by any device except the 21150 on the secondary bus to indicate a system error condition. The 21150 samples s_serr_l as an input and conditionally forwards it to the primary bus on p_serr_l. The 21150 does not drive s_serr_l. Signal s_serr_l is pulled up through an external resistor.

2.3 Secondary Bus Arbitration Signals

Table 6 describes the secondary bus arbitration signals.

Table 6. Secondary PCI Bus Interface Signals (Sheet 1 of 2)

Signal Name	Type	Description
s_req_l<8:0>	I	Secondary PCI interface REQ#s. The 21150 accepts nine request inputs, s_req_l<8:0>, into its secondary bus arbiter. The 21150 request input to the arbiter is an internal signal. Each request input can be programmed to be in either a high priority rotating group or a low priority rotating group. An asserted level on an s_req_l pin indicates that the corresponding master wants to initiate a transaction on the secondary PCI bus. If the internal arbiter is disabled (s_cfn_l tied high), s_req_l<0> is reconfigured to be an external secondary grant input for the 21150. In this case, an asserted level on s_req_l<0> indicates that the 21150 can start a transaction on the secondary PCI bus if the bus is idle.
s_gnt_l<8:0>	TS	Secondary PCI interface GNT#s. The 21150 secondary bus arbiter can assert one of nine secondary bus grant outputs, s_gnt_l<8:0>, to indicate that an initiator can start a transaction on the secondary bus if the bus is idle. The 21150's secondary bus grant is an internal signal. A programmable 2-level rotating priority algorithm is used. If the internal arbiter is disabled (s_cfn_l tied high), s_gnt_l<0> is reconfigured to be an external secondary bus request output for the 21150. The 21150 asserts this signal whenever it wants to start a transaction on the secondary bus.

Table 6. Secondary PCI Bus Interface Signals (Sheet 2 of 2)

s_cfn_l	I	Secondary PCI central function enable. When tied low, s_cfn_l enables the 21150 secondary bus arbiter. When tied high, s_cfn_l disables the internal arbiter. An external secondary bus arbiter must then be used. Signal s_req_l<0> is reconfigured to be the 21150 secondary bus grant input, and s_gnt_l<0> is reconfigured to be the 21150 secondary bus request output, when an external arbiter is used. Secondary bus parking is done when s_req_l<0> is asserted, the secondary bus is idle, and the 21150 does not want to initiate a transaction.
---------	---	---

2.4 General-Purpose I/O Interface Signals

Table 7 describes the general-purpose I/O interface signals.

Table 7. General-Purpose I/O Interface Signals

Signal Name	Type	Description
gpio<3:0>	TS	<p>General-purpose I/O data. These four general-purpose signals are programmable as either input-only or bidirectional signals by writing the gpio output enable control register in configuration space. The value on these signals is reflected in a gpio input data configuration register when read. Levels to be driven on gpio pins configured as bidirectional are derived from the value written in the gpio output data configuration register.</p> <p>During the first 23 clock cycles (46 cycles when s_clk operates at 66 MHz) while p_rst_l is deasserted and s_rst_l is asserted, the gpio signals are used to control an external shift register that can shift in a serial clock disable mask into the msk_in input. The gpio pins should not be driven by software during these 23 clock cycles. The mask can then be read and modified in the secondary clock control register in configuration space.</p>

2.5 Clock Signals

Table 8 describes the clock signals.

Table 8. Clock Signals (Sheet 1 of 2)

Signal Name	Type	Description
p_clk	I	Primary interface PCI CLK. Provides timing for all transactions on the primary PCI bus. All primary PCI inputs are sampled on the rising edge of p_clk, and all primary PCI outputs are driven from the rising edge of p_clk. Frequencies supported by the 21150 range from 0 MHz to 33 MHz, or 0 MHz to 66 MHz for a 66 MHz capable 21150.

Table 8. Clock Signals (Sheet 2 of 2)

s_clk	I	Secondary interface PCI CLK. Provides timing for all transactions on the secondary PCI bus. All secondary PCI inputs are sampled on the rising edge of s_clk, and all secondary PCI outputs are driven from the rising edge of s_clk. Frequencies supported by the 21150 range from 0 MHz to 33 MHz, or 0 MHz to 66 MHz for a 66 MHz capable 21150.
s_clk_o<9:0>	O	Secondary interface PCI CLK outputs. Signals s_clk_o<9:0> are 10 clock outputs generated from the primary interface clock input, p_clk. These clocks operate at the same frequency of p_clk, or at half the p_clk frequency when the primary bus frequency is 66 MHz and the secondary bus frequency is 33 MHz. When these clocks are used, one of the clock outputs must be fed back to the secondary clock input, s_clk. Unused clock outputs can be disabled by using the serial disable mask mechanism using the gpio pins and msk_in or by writing the secondary clock disable bits in configuration space; otherwise, terminate them electrically.

2.6 Reset Signals

Table 9 describes the reset signals.

Table 9. Reset Signals

Signal Name	Type	Description
bpcce ¹	I	Bus/power clock control management pin. When signal bpcce is tied high, and when the 21150 is placed in the D3 _{hot} power state, it enables the 21150 to place the secondary bus in the B2 power state. The 21150 disables the secondary clocks and drives them to 0. When tied low, placing the 21150 in the D3 _{hot} power state has no effect on the secondary bus clocks.
p_rst_l	I	Primary PCI bus RST#. Signal p_rst_l forces the 21150 to a known state. All register state is cleared, and all primary PCI bus outputs are tristated. Signal p_rst_l is asynchronous to p_clk.
s_rst_l	O	Secondary PCI bus RST#. Signal s_rst_l is driven by the 21150 and acts as the PCI reset for the secondary bus. The 21150 asserts s_rst_l when any of the following conditions is met: <ul style="list-style-type: none"> • Signal p_rst_l is asserted. • The secondary reset bit in the bridge control register in configuration space is set. • The chip reset bit in the diagnostic control register in configuration space is set. When the 21150 asserts s_rst_l, it tristates all secondary control signals and drives zeros on s_ad, s_cbe_l, and s_par. Signal s_rst_l remains asserted until p_rst_l is deasserted, the gpio serial clock mask has been shifted in, and the secondary reset bit is clear. Assertion of s_rst_l by itself does not clear register state, and configuration registers are still accessible from the primary PCI interface.

¹ For 21150-AB and later revisions only

2.7 Miscellaneous Signals

Table 10 describes the miscellaneous signals.

Table 10. Miscellaneous Signals

Signal Name	Type	Description
misk_in	I	Secondary clock disable serial input. This input-only signal is used by the hardware mechanism to disable secondary clock outputs. The serial stream is received by misk_in, starting when p_rst is detected deasserted and s_rst_l is detected asserted. This serial data is used for selectively disabling secondary clock outputs and is shifted into the secondary clock control configuration register. This input can be tied low to enable all secondary clock outputs, or tied high to drive all secondary clock outputs high.
p_vio	I	Primary interface I/O voltage. This signal must be tied to either 3.3 V or 5 V, corresponding to the signaling environment of the primary PCI bus as described in the <i>PCI Local Bus Specification, Revision 2.1</i> . When any device on the primary PCI bus uses 5-V signaling levels, tie p_vio to 5 V. Signal p_vio is tied to 3.3 V only when all the devices on the primary bus use 3.3-V signaling levels.
s_vio	I	Secondary interface I/O voltage. This signal must be tied to either 3.3 V or 5 V, corresponding to the signaling environment of the secondary PCI bus as described in the <i>PCI Local Bus Specification, Revision 2.1</i> . When any device on the secondary PCI bus uses 5-V signaling levels, tie s_vio to 5 V. Signal s_vio is tied to 3.3 V only when all the devices on the secondary bus use 3.3-V signaling levels.
config66	I	Configure 66 MHz operation. This input only pin is used to specify if the 21150 is capable of running at 66 MHz. If the pin is tied high, then the device can be run at 66 MHz. If the pin is tied low, then the 21150 can only function under the 33 MHz PCI specification.
p_m66ena	I	Primary interface 66 MHz enable. This input-only signal pin is used to designate the primary interface bus speed. This signal should be pulled low for 33 MHz operation on the primary bus. In this case, the s_m66ena pin will be driven low, forcing the secondary interface to also run at 33 MHz. For 66 MHz operation on the primary bus, this signal should be pulled high.
s_m66ena	I/OD	Secondary interface 66 MHz enable. This signal pin is used to designate the secondary interface bus speed. If the primary bus is operating at 33 MHz (i.e. if p_m66ena is low), then the s_m66ena pin will be driven low by the 21150 forcing the secondary bus to operate at 33 MHz. If the primary bus is operating at 66 MHz, then the s_m66ena pin is an input and should be externally pulled high for the secondary bus to operate at 66 MHz or low for the secondary bus to operate at 33 MHz.

2.8 JTAG Signals

Table 11 describes the JTAG signals.

Table 11. JTAG Signals

Signal Name	Type	Description
tdi	I	JTAG serial data in. Signal tdi is the serial input through which JTAG instructions and test data enter the JTAG interface. The new data on tdi is sampled on the rising edge of tck. An unterminated tdi produces the same result as if tdi were driven high.
tdo	O	JTAG serial data out. Signal tdo is the serial output through which test instructions and data from the test logic leave the 21150.
tms	I	JTAG test mode select. Signal tms causes state transitions in the test access port (TAP) controller. An undriven tms has the same result as if it were driven high.
tck	I	JTAG boundary-scan clock. Signal tck is the clock controlling the JTAG logic.
trst_l	I	JTAG TAP reset. When asserted low, the TAP controller is asynchronously forced to enter a reset state, which in turn asynchronously initializes other test logic. An unterminated trst_l produces the same result as if it were driven high.

3.0 Pin Assignments

This chapter describes the 21150 pins. It provides numeric and alphabetic lists of the pins and includes a diagram showing 21150 pin assignment.

Figure 5 shows the 21150 pins. Table 13 and Table 14 list the pins in numeric and alphabetic order.

Figure 5. 21150 Pin Assignment

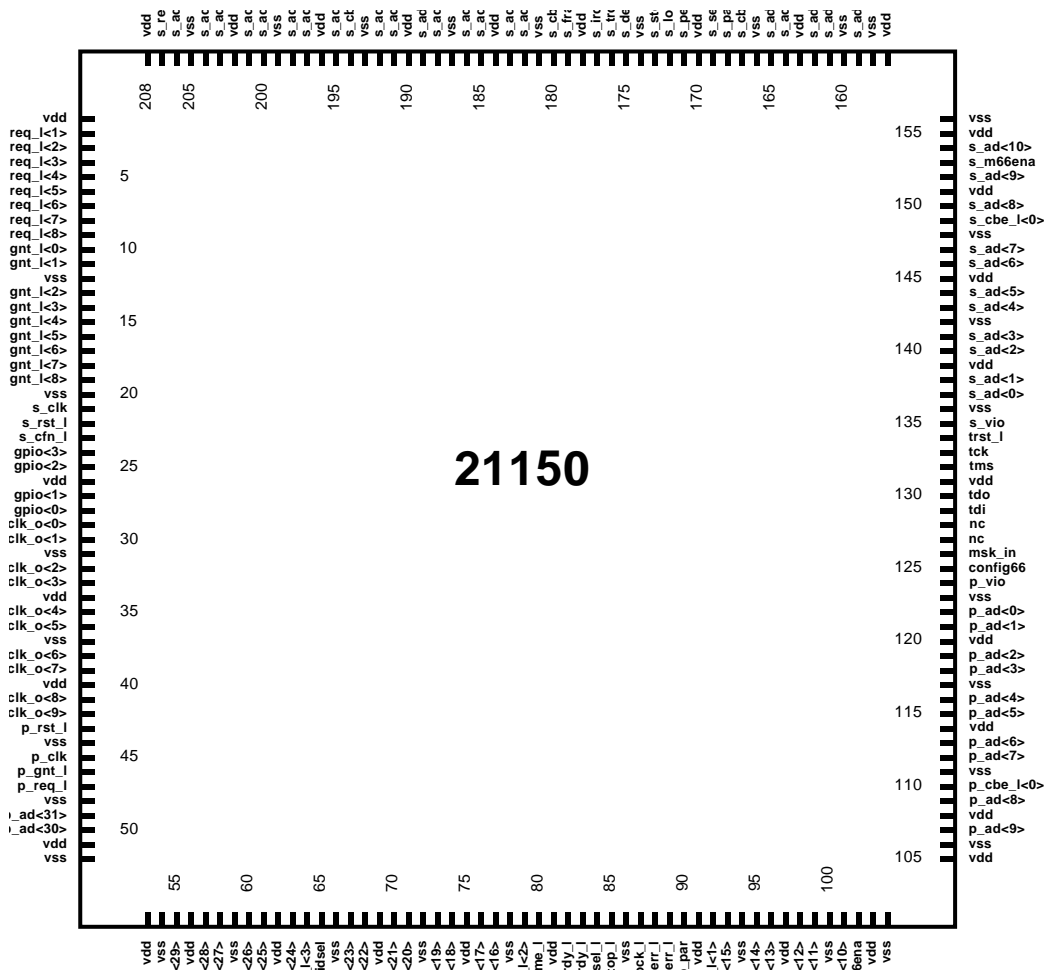

3.1 Numeric Pin Assignment

Table 13 lists the 21150 pins in numeric order, showing the name, number, and signal type of each pin. Table 12 defines the signal type abbreviations.

Table 12. Signal Types

Signal Type	Description
I	Standard input only.
O	Standard output only.
P	Power.
TS	Tristate bidirectional.
STS	Sustained tristate. Active low signal must be pulled high for one cycle when deasserting.
OD	Standard open drain.

Table 13. Numeric Pin Assignments (Sheet 1 of 3)

Pin	Pin Number	Type	Pin	Pin Number	Type
vdd	1	P	vss	37	P
s_req_l<1>	2	I	s_clk_o<6>	38	O
s_req_l<2>	3	I	s_clk_o<7>	39	O
s_req_l<3>	4	I	vdd	40	P
s_req_l<4>	5	I	s_clk_o<8>	41	O
s_req_l<5>	6	I	s_clk_o<9>	42	O
s_req_l<6>	7	I	p_rst_l	43	I
s_req_l<7>	8	I	bpcce ¹	44	I
s_req_l<8>	9	I	p_clk	45	I
s_gnt_l<0>	10	TS	p_gnt_l	46	I
s_gnt_l<1>	11	TS	p_req_l	47	TS
vss	12	P	vss	48	P
s_gnt_l<2>	13	TS	p_ad<31>	48	TS
s_gnt_l<3>	14	TS	p_ad<30>	50	TS
s_gnt_l<4>	15	TS	vdd	51	P
s_gnt_l<5>	16	TS	vss	52	P
s_gnt_l<6>	17	TS	vdd	53	P
s_gnt_l<7>	18	TS	vss	54	P
s_gnt_l<8>	19	TS	p_ad<29>	55	TS
vss	20	P	vdd	56	P
s_clk	21	I	p_ad<28>	57	TS
s_rst_l	22	O	p_ad<27>	58	TS
s_cfn_l	23	I	vss	59	P
gpio<3>	24	TS	p_ad<26>	60	TS
gpio<2>	25	TS	p_ad<25>	61	TS
vdd	26	P	vdd	62	P
gpio<1>	27	TS	p_ad<24>	63	TS
gpio<0>	28	TS	p_cbe_l<3>	64	TS
s_clk_o<0>	29	O	p_idsel	65	I
s_clk_o<1>	30	O	vss	66	P
vss	31	P	p_ad<23>	67	TS
s_clk_o<2>	32	O	p_ad<22>	68	TS
s_clk_o<3>	33	O	vdd	69	P
vdd	34	P	p_ad<21>	70	TS
s_clk_o<4>	35	O	p_ad<20>	71	TS
s_clk_o<5>	36	O	vss	72	P

Table 13. Numeric Pin Assignments (Sheet 2 of 3)

Pin	Pin Number	Type	Pin	Pin Number	Type
p_ad<19>	73	TS	p_cbe_l<0>	110	TS
p_ad<18>	74	TS	vss	111	P
vdd	75	P	p_ad<7>	112	TS
p_ad<17>	76	TS	p_ad<6>	113	TS
p_ad<16>	77	TS	vdd	114	P
vss	78	P	p_ad<5>	115	TS
p_cbe_l<2>	79	TS	p_ad<4>	116	TS
p_frame_l	80	STS	vss	117	P
vdd	81	P	p_ad<3>	118	TS
p_irdy_l	82	STS	p_ad<2>	119	TS
p_trdy_l	83	STS	vdd	120	P
p_devsel_l	84	STS	p_ad<1>	121	TS
p_stop_l	85	STS	p_ad<0>	122	TS
vss	86	P	vss	123	P
p_lock_l	87	STS	p_vio	124	I
p_perr_l	88	STS	config66	125	I
p_serr_l	89	OD	msk_in	126	I
p_par	90	TS	nc ²	127	—
vdd	91	P	nc ²	128	—
p_cbe_l<1>	92	TS	tdi	129	I
p_ad<15>	93	TS	tdo	130	O
vss	94	P	vdd	131	P
p_ad<14>	95	TS	tms	132	I
p_ad<13>	96	TS	tck	133	I
vdd	97	P	trst_l	134	I
p_ad<12>	98	TS	s_vio	135	I
p_ad<11>	99	TS	vss	136	P
vss	100	P	s_ad<0>	137	TS
p_ad<10>	101	TS	s_ad<1>	138	TS
p_m66ena	102	I	vdd	139	P
vdd	103	P	s_ad<2>	140	TS
vss	104	P	s_ad<3>	141	TS
vdd	105	P	vss	142	P
vss	106	P	s_ad<4>	143	TS
p_ad<9>	107	TS	s_ad<5>	144	TS
vdd	108	P	vdd	145	P
p_ad<8>	109	TS	s_ad<6>	146	TS

Table 13. Numeric Pin Assignments (Sheet 3 of 3)

Pin	Pin Number	Type	Pin	Pin Number	Type
s_ad<7>	147	TS	vdd	178	P
vss	148	P	s_frame_l	179	STS
s_cbe_l<0>	149	TS	s_cbe_l<2>	180	TS
s_ad<8>	150	TS	vss	181	P
vdd	151	P	s_ad<16>	182	TS
s_ad<9>	152	TS	s_ad<17>	183	TS
s_m66ena	153	OD	vdd	184	P
s_ad<10>	154	TS	s_ad<18>	185	TS
vdd	155	P	s_ad<19>	186	TS
vss	156	P	vss	187	P
vdd	157	P	s_ad<20>	188	TS
vss	158	P	s_ad<21>	189	TS
s_ad<11>	159	TS	vdd	190	P
vss	160	P	s_ad<22>	191	TS
s_ad<12>	161	TS	s_ad<23>	192	TS
s_ad<13>	162	TS	vss	193	P
vdd	163	P	s_cbe_l<3>	194	TS
s_ad<14>	164	TS	s_ad<24>	195	TS
s_ad<15>	165	TS	vdd	196	P
vss	166	P	s_ad<25>	197	TS
s_cbe<1>	167	TS	s_ad<26>	198	TS
s_par	168	TS	vss	199	P
s_serr_l	169	I	s_ad<27>	200	TS
vdd	170	P	s_ad<28>	201	TS
s_perr_l	171	STS	vdd	202	P
s_lock_l	172	STS	s_ad<29>	203	TS
s_stop_l	173	STS	s_ad<30>	204	TS
vss	174	P	vss	205	P
s_devsel_l	175	STS	s_ad<31>	206	TS
s_trdy_l	176	STS	s_req_l<0>	207	I
s_irdy_l	177	STS	vdd	208	P

¹ Pertains to the 21150-AB and later revisions only. For the 21150-AA, this pin was vss.
² nc—Do not connect these pins on the board.

3.2 Alphabetic Pin Assignment

Table 14 lists the 21150 pins in alphabetic order, showing the name, number, and signal type of each pin. Table 12 defines the signal type abbreviations.

Table 14. Alphabetic Pin Assignments. (Sheet 1 of 3)

Pin	Pin Number	Type	Pin	Pin Number	Type
bpcce ¹	44	I	p_ad<21>	70	TS
config66	125	I	p_ad<22>	68	TS
s_m66ena	153	OD	p_ad<23>	67	TS
p_m66ena	102	I	p_ad<24>	63	TS
gpio<0>	28	TS	p_ad<25>	61	TS
gpio<1>	27	TS	p_ad<26>	60	TS
gpio<2>	25	TS	p_ad<27>	58	TS
gpio<3>	24	TS	p_ad<28>	57	TS
msk_in	126	I	p_ad<29>	55	TS
nc ²	127	—	p_ad<30>	50	TS
nc	128	—	p_ad<31>	49	TS
p_ad<0>	122	TS	p_cbe_l<0>	110	TS
p_ad<1>	121	TS	p_cbe_l<1>	92	TS
p_ad<2>	119	TS	p_cbe_l<2>	79	TS
p_ad<3>	118	TS	p_cbe_l<3>	64	TS
p_ad<4>	116	TS	p_clk	45	I
p_ad<5>	115	TS	p_devsel_l	84	STS
p_ad<6>	113	TS	p_frame_l	80	STS
p_ad<7>	112	TS	p_gnt_l	46	I
p_ad<8>	109	TS	p_idsel	65	I
p_ad<9>	107	TS	p_irdy_l	82	STS
p_ad<10>	101	TS	p_lock	87	STS
p_ad<11>	99	TS	p_par	90	TS
p_ad<12>	98	TS	p_perr_l	88	STS
p_ad<13>	96	TS	p_req_l	47	TS
p_ad<14>	95	TS	p_rst_l	43	I
p_ad<15>	93	TS	p_serr_l	89	OD
p_ad<16>	77	TS	p_stop_l	85	STS
p_ad<17>	76	TS	p_trdy_l	83	STS
p_ad<18>	74	TS	p_vio	124	I
p_ad<19>	73	TS	s_ad<0>	137	TS
p_ad<20>	71	TS	s_ad<1>	138	TS

Table 14. Alphabetic Pin Assignments. (Sheet 2 of 3)

Pin	Pin Number	Type	Pin	Pin Number	Type
s_ad<2>	140	TS	s_clk_o<1>	30	O
s_ad<3>	141	TS	s_clk_o<2>	32	O
s_ad<4>	143	TS	s_clk_o<3>	33	O
s_ad<5>	144	TS	s_clk_o<4>	35	O
s_ad<6>	146	TS	s_clk_o<5>	36	O
s_ad<7>	147	TS	s_clk_o<6>	38	O
s_ad<8>	150	TS	s_clk_o<7>	39	O
s_ad<9>	152	TS	s_clk_o<8>	41	O
s_ad<10>	154	TS	s_clk_o<9>	42	O
s_ad<11>	159	TS	s_devsel_l	175	STS
s_ad<12>	161	TS	s_frame_l	179	STS
s_ad<13>	162	TS	s_gnt_l<0>	10	TS
s_ad<14>	164	TS	s_gnt_l<1>	11	TS
s_ad<15>	165	TS	s_gnt_l<2>	13	TS
s_ad<16>	182	TS	s_gnt_l<3>	14	TS
s_ad<17>	183	TS	s_gnt_l<4>	15	TS
s_ad<18>	185	TS	s_gnt_l<5>	16	TS
s_ad<19>	186	TS	s_gnt_l<6>	17	TS
s_ad<20>	188	TS	s_gnt_l<7>	18	TS
s_ad<21>	189	TS	s_gnt_l<8>	19	TS
s_ad<22>	191	TS	s_irdy_l	177	STS
s_ad<23>	192	TS	s_lock_l	172	STS
s_ad<24>	195	TS	s_par_l	168	TS
s_ad<25>	197	TS	s_perr_l	171	STS
s_ad<26>	198	TS	s_req_l<0>	207	I
s_ad<27>	200	TS	s_req_l<1>	2	I
s_ad<28>	201	TS	s_req_l<2>	3	I
s_ad<29>	203	TS	s_req_l<3>	4	I
s_ad<30>	204	TS	s_req_l<4>	5	I
s_ad<31>	206	TS	s_req_l<5>	6	I
s_cbe_l<0>	149	TS	s_req_l<6>	7	I
s_cbe_l<1>	167	TS	s_req_l<7>	8	I
s_cbe_l<2>	180	TS	s_req_l<8>	9	I
s_cbe_l<3>	194	TS	s_rst_l	22	O
s_cfn_l	23	O	s_serr_l	169	I
s_clk	21	I	s_stop_l	173	STS
s_clk_o<0>	29	O	s_trdy_l	176	STS

Table 14. Alphabetic Pin Assignments. (Sheet 3 of 3)

Pin	Pin Number	Type	Pin	Pin Number	Type
s_vio	135	I	vdd	196	P
tck	133	I	vdd	202	P
tdi	129	I	vdd	208	P
tdo	130	O	vss	12	P
tms	132	I	vss	20	P
trst_l	134	I	vss	31	P
vdd	1	P	vss	37	P
vdd	26	P	vss	48	P
vdd	34	P	vss	52	P
vdd	40	P	vss	54	P
vdd	51	P	vss	59	P
vdd	53	P	vss	66	P
vdd	56	P	vss	72	P
vdd	62	P	vss	78	P
vdd	69	P	vss	86	P
vdd	75	P	vss	94	P
vdd	81	P	vss	100	P
vdd	91	P	vss	104	P
vdd	97	P	vss	106	P
vdd	103	P	vss	111	P
vdd	105	P	vss	117	P
vdd	108	P	vss	123	P
vdd	114	P	vss	136	P
vdd	120	P	vss	142	P
vdd	131	P	vss	148	P
vdd	139	P	vss	156	P
vdd	145	P	vss	158	P
vdd	151	P	vss	160	P
vdd	155	P	vss	166	P
vdd	157	P	vss	174	P
vdd	163	P	vss	181	P
vdd	170	P	vss	187	P
vdd	178	P	vss	193	P
vdd	184	P	vss	199	P
vdd	190	P	vss	205	P

¹ Pertains to the 21150-AB and later revisions only. For the 21150-AA, this pin was vss.

² nc—Do not connect these pins on the board.

4.0 PCI Bus Operation

This chapter presents detailed information about PCI transactions, transaction forwarding across the 21150, and transaction termination.

4.1 Types of Transactions

This section provides a summary of PCI transactions performed by the 21150.

Table 15 lists the command code and name of each PCI transaction. The Master and Target columns indicate 21150 support for each transaction when the 21150 initiates transactions as a master, on the primary bus and on the secondary bus, and when the 21150 responds to transactions as a target, on the primary bus and on the secondary bus.

Table 15. 21150 PCI Transactions

	21150 Initiates as Master		21150 Initiates as Target	
	Primary	Secondary	Primary	Secondary
0000—Interrupt acknowledge	No	No	No	No
0001—Special cycle	Yes	Yes	No	No
0010—I/O read	Yes	Yes	Yes	Yes
0011—I/O write	Yes	Yes	Yes	Yes
0100—Reserved	No	No	No	No
0101—Reserved	No	No	No	No
0110—Memory read	Yes	Yes	Yes	Yes
0111—Memory write	Yes	Yes	Yes	Yes
1000—Reserved	No	No	No	No
1001—Reserved	No	No	No	No
1010—Configuration read	No	Yes	Yes	No
1011—Configuration write	Type 1	Yes	Yes	Type 1
1100—Memory read multiple	Yes	Yes	Yes	Yes
1101—Dual address cycle	Yes	Yes	Yes	Yes
1110—Memory read line	Yes	Yes	Yes	Yes
1111—Memory write and invalidate	Yes	Yes	Yes	Yes

As indicated in Table 15, the following PCI commands are not supported by the 21150:

- The 21150 never initiates a PCI transaction with a reserved command code and, as a target, the 21150 ignores reserved command codes.
- The 21150 never initiates an interrupt acknowledge transaction and, as a target, the 21150 ignores interrupt acknowledge transactions. Interrupt acknowledge transactions are expected to reside entirely on the primary PCI bus closest to the host bridge.
- The 21150 does not respond to special cycle transactions. The 21150 cannot guarantee delivery of a special cycle transaction to downstream buses because of the broadcast nature of the special cycle command and the inability to control the transaction as a target. To generate

special cycle transactions on other PCI buses, either upstream or downstream, a Type 1 configuration command must be used.

- The 21150 does not generate Type 0 configuration transactions on the primary interface, nor does it respond to Type 0 configuration transactions on the secondary PCI interface. The *PCI-to-PCI Bridge Architecture Specification* does not support configuration from the secondary bus.

4.2 Address Phase

The standard PCI transaction consists of one or two address phases, followed by one or more data phases. An address phase always lasts one PCI clock cycle. The first address phase is designated by an asserting (falling) edge on the FRAME# signal. The number of address phases depends on whether the address is 32 bits or 64 bits.

4.2.1 Single Address Phase

A 32-bit address uses a single address phase. This address is driven on AD<31:0>, and the bus command is driven on C/BE#<3:0>.

The 21150 supports the linear increment address mode only, which is indicated when the low 2 address bits are equal to 0. If either of the low 2 address bits is nonzero, the 21150 automatically disconnects the transaction after the first data transfer.

4.2.2 Dual Address Phase

Dual address transactions are PCI transactions that contain two address phases specifying a 64-bit address.

The first address phase is denoted by the asserting edge of FRAME#.

The second address phase always follows on the next clock cycle.

For a 32-bit interface, the first address phase contains the dual address command code on the C/BE#<3:0> lines, and the low 32 address bits on the AD<31:0> lines. The second address phase consists of the specific memory transaction command code on the C/BE#<3:0> lines, and the high 32 address bits on the AD<31:0> lines. In this way, 64-bit addressing can be supported on 32-bit PCI buses.

The *PCI-to-PCI Bridge Architecture Specification* supports the use of dual address transactions in the prefetchable memory range only. See [Section 5.3](#) for a discussion of prefetchable address space. The 21150 supports dual address transactions in both the upstream and the downstream direction. The 21150 supports a programmable 64-bit address range in prefetchable memory for downstream forwarding of dual address transactions. Dual address transactions falling outside the prefetchable address range are forwarded upstream, but not downstream. Prefetching and posting are performed in a manner consistent with the guidelines given in this specification for each type of memory transaction in prefetchable memory space.

The 21150 responds only to dual address transactions that use the following transaction command codes:

- Memory write
- Memory write and invalidate
- Memory read
- Memory read line
- Memory read multiple

Use of other transaction codes may result in a master abort.

Any memory transactions addressing the first 4GB space should use a single address phase; that is, the high 32 bits of a dual address transaction should never be 0.

4.3 Device Select (DEVSEL#) Generation

The 21150 always performs positive address decoding when accepting transactions on either the primary or secondary buses. The 21150 never subtractively decodes. Medium DEVSEL# timing is used on both interfaces.

4.4 Data Phase

The address phase or phases of a PCI transaction are followed by one or more data phases. A data phase is completed when IRDY# and either TRDY# or STOP# are asserted. A transfer of data occurs only when both IRDY# and TRDY# are asserted during the same PCI clock cycle. The last data phase of a transaction is indicated when FRAME# is deasserted and both TRDY# and IRDY# are asserted, or when IRDY# and STOP# are asserted. See [Section 4.8](#) for further discussion of transaction termination.

Depending on the command type, the 21150 can support multiple data phase PCI transactions. For a detailed description of how the 21150 imposes disconnect boundaries, see [Section 4.5.4](#) for a description of write address boundaries and [Section 4.6.3](#) for a description of read address boundaries.

4.5 Write Transactions

Write transactions are treated as either posted write or delayed write transactions. [Table 16](#) shows the method of forwarding used for each type of write operation.

Table 16. Write Transaction Forwarding

Type of Transaction	Type of Forwarding
Memory write	Posted
Memory write and invalidate	Posted
I/O write	Delayed
Type 1 configuration write	Delayed

4.5.1 Posted Write Transactions

Posted write forwarding is used for memory write and for memory write and invalidate transactions.

When the 21150 determines that a memory write transaction is to be forwarded across the bridge, the 21150 asserts DEVSEL# with medium timing and TRDY# in the same cycle, provided that enough buffer space is available in the posted data queue for the address and at least 8 Dwords of data. This enables the 21150 to accept write data without obtaining access to the target bus. The 21150 can accept 1 Dword of write data every PCI clock cycle; that is, no target wait states are inserted. This write data is stored in internal posted write buffers and is subsequently delivered to the target.

The 21150 continues to accept write data until one of the following events occurs:

- The initiator terminates the transaction by deasserting FRAME# and IRDY#.
- An internal write address boundary is reached, such as a cache line boundary or an aligned 4KB boundary, depending on the transaction type.
- The posted write data buffer fills up.

When one of the last two events occurs, the 21150 returns a target disconnect to the requesting initiator on this data phase to terminate the transaction. Once the posted write data moves to the head of the posted data queue, the 21150 asserts its request on the target bus. This can occur while the 21150 is still receiving data on the initiator bus. When the grant for the target bus is received and the target bus is detected in the idle condition, the 21150 asserts FRAME# and drives the stored write address out on the target bus. On the following cycle, the 21150 drives the first Dword of write data and continues to transfer write data until all write data corresponding to that transaction is delivered, or until a target termination is received. As long as write data exists in the queue, the 21150 can drive 1 Dword of write data each PCI clock cycle; that is, no master wait states are inserted. If write data is flowing through the 21150 and the initiator stalls, the 21150 may have to insert wait states on the target bus if the queue empties.

[Figure 6](#) shows a memory write transaction in flow-through mode, where data is being removed from buffers on the target interface while more data is being transferred into the buffers on the master interface.

Figure 6. Flow-Through Posted Memory Write Transaction

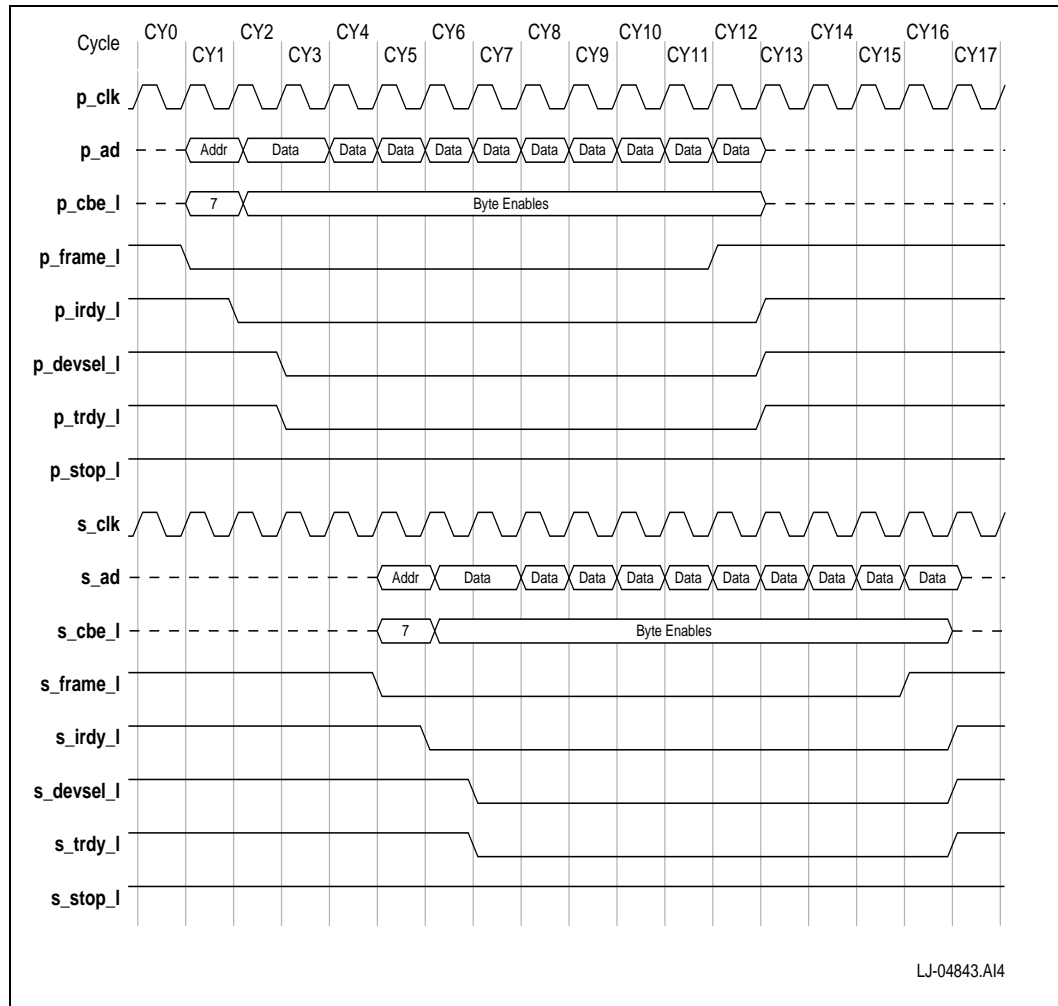

The 21150 ends the transaction on the target bus when one of the following conditions is met:

- All posted write data has been delivered to the target.
- The target returns a target disconnect or target retry (the 21150 starts another transaction to deliver the rest of the write data).
- The target returns a target abort (the 21150 discards remaining write data).
- The master latency timer expires, and the 21150 no longer has the target bus grant (the 21150 starts another transaction to deliver remaining write data).

[Section 4.8.3.2](#) provides detailed information about how the 21150 responds to target termination during posted write transactions.

4.5.2 Memory Write and Invalidate Transactions

Posted write forwarding is used for memory write and invalidate transactions. Memory write and invalidate transactions guarantee transfer of entire cache lines. If the write buffer fills before an entire cache line is transferred, the 21150 disconnects the transaction and converts it to a memory write transaction.

The 21150 disconnects memory write and invalidate commands at aligned cache line boundaries. The cache line size value in the 21150 cache line size register gives the number of Dwords in a cache line. For the 21150 to generate memory write and invalidate transactions, this cache line size value must be written to a value that is a nonzero power of 2 and less than or equal to 16 (that is, 1, 2, 4, 8, or 16 Dwords).

If the cache line size does not meet the memory write and invalidate conditions, that is, the value is 0, or is not a power of 2, or is greater than 16 Dwords, the 21150 treats the memory write and invalidate command as a memory write command. In this case, when the 21150 forwards the memory write and invalidate transaction to the target bus, it converts the command code to a memory write code and does not observe cache line boundaries.

If the value in the cache line size register does meet the memory write and invalidate conditions, that is, the value is a nonzero power of 2 less than or equal to 16 Dwords, the 21150 returns a target disconnect to the initiator either on a cache line boundary or when the posted write buffer fills. For a cache line size of 16 Dwords, the 21150 disconnects a memory write and invalidate transaction on every cache line boundary. When the cache line size is 1, 2, 4, or 8 Dwords, the 21150 accepts another cache line if at least 8 Dwords of empty space remains in the posted write buffer. If less than 8 Dwords of empty space remains, the 21150 disconnects on that cache line boundary.

When the memory write and invalidate transaction is disconnected before a cache line boundary is reached, typically because the posted write buffer fills, the transaction is converted to a memory write transaction.

4.5.3 Delayed Write Transactions

Delayed write forwarding is used for I/O write transactions and for Type 1 configuration write transactions.

A delayed write transaction guarantees that the actual target response is returned back to the initiator without holding the initiating bus in wait states. A delayed write transaction is limited to a single Dword data transfer.

When a write transaction is first detected on the initiator bus, and the 21150 forwards it as a delayed transaction, the 21150 claims the access by asserting DEVSEL# and returns a target retry to the initiator. During the address phase, the 21150 samples the bus command, address, and address parity one cycle later. After IRDY# is asserted, the 21150 also samples the first data Dword, byte enable bits, and data parity. This information is placed into the delayed transaction queue. The transaction is queued only if no other existing delayed transactions have the same address and command, and if the delayed transaction queue is not full. When the delayed write transaction moves to the head of the delayed transaction queue and all ordering constraints with posted data are satisfied (see [Section 6.0](#)), the 21150 initiates the transaction on the target bus. The 21150 transfers the write data to the target. If the 21150 receives a target retry in response to the write transaction on the target bus, it continues to repeat the write transaction until the data transfer is completed, or until an error condition is encountered.

If the 21150 is unable to deliver write data after 2^{24} attempts, the 21150 ceases further write attempts and returns a target abort to the initiator. The delayed transaction is removed from the delayed transaction queue. The 21150 also asserts `p_serr_1` if the primary `SERR#` enable bit is set in the command register. See [Section 7.4](#) for information on the assertion of `p_serr_1`.

When the initiator repeats the same write transaction (same command, address, byte enable bits, and data), and the completed delayed transaction is at the head of the queue, the 21150 claims the access by asserting `DEVSEL#` and returns `TRDY#` to the initiator, to indicate that the write data was transferred. If the initiator requests multiple Dwords, the 21150 also asserts `STOP#` in conjunction with `TRDY#` to signal a target disconnect. Note that only those bytes of write data with valid byte enable bits are compared. If any of the byte enable bits are turned off (driven high), the corresponding byte of write data is not compared.

If the initiator repeats the write transaction before the data has been transferred to the target, the 21150 returns a target retry to the initiator. The 21150 continues to return a target retry to the initiator until write data is delivered to the target, or until an error condition is encountered. When the write transaction is repeated, the 21150 does not make a new entry into the delayed transaction queue. [Section 4.8.3.1](#) provides detailed information about how the 21150 responds to target termination during delayed write transactions.

[Figure 7](#) shows a delayed write transaction forwarded downstream across the 21150.

Figure 7. Downstream Delayed Write Transaction

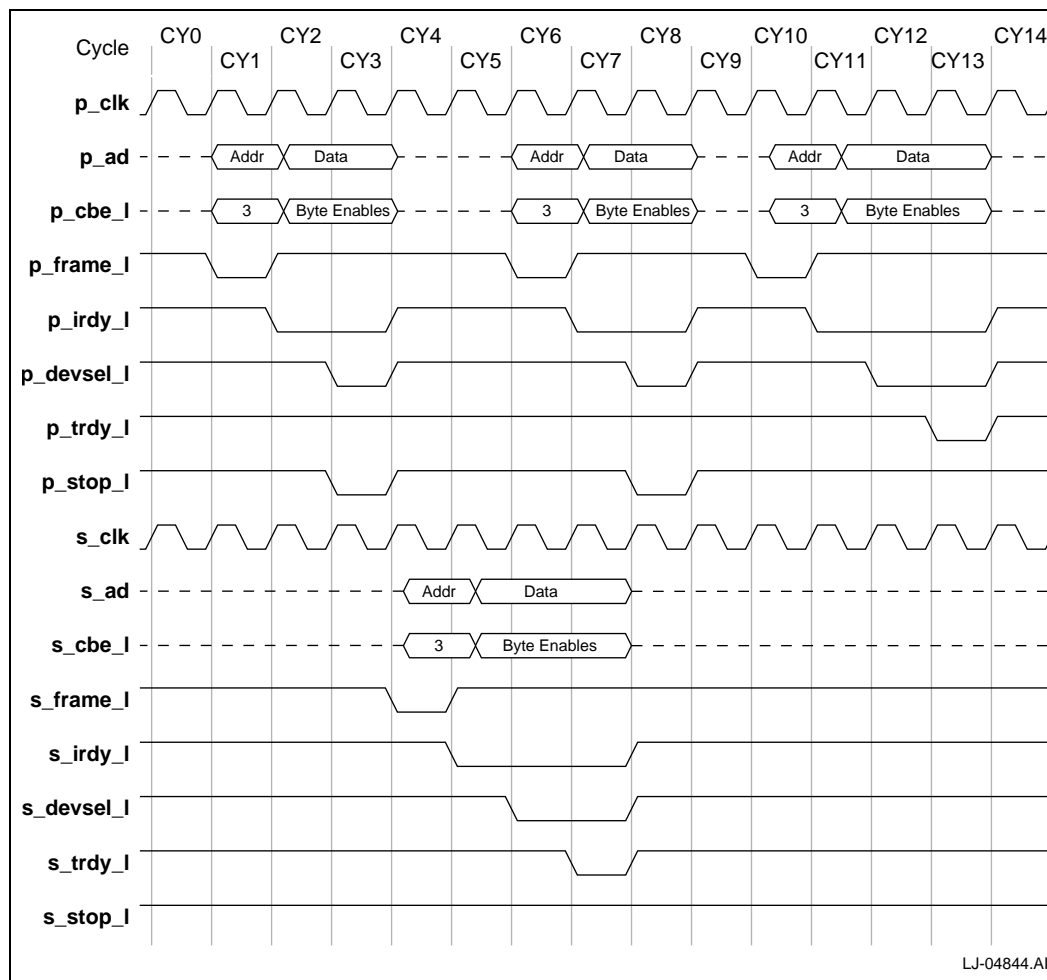

The 21150 implements a discard timer that starts counting when the delayed write completion is at the head of the delayed transaction queue. The initial value of this timer can be set to one of two values, selectable through both the primary and secondary master timeout bits in the bridge control register. If the initiator does not repeat the delayed write transaction before the discard timer expires, the 21150 discards the delayed write transaction from the delayed transaction queue. The 21150 also conditionally asserts `p_serr_l` (see [Section 7.4](#)).

4.5.4 Write Transaction Address Boundaries

The 21150 imposes internal address boundaries when accepting write data. The aligned address boundaries are used to prevent the 21150 from continuing a transaction over a device address boundary and to provide an upper limit on maximum latency. The 21150 returns a target disconnect to the initiator when it reaches the aligned address boundaries under the conditions shown in [Table 17](#).

Table 17. Write Transaction Disconnect Address Boundaries

Type of Transaction	Condition	Aligned Address Boundary
Delayed write	All	Disconnects after one data transfer
Posted memory write	Memory write disconnect control bit = 0 ¹	4KB aligned address boundary
Posted memory write	Memory write disconnect control bit = 1 ¹	Disconnects at cache line boundary
Posted memory write and invalidate	Cache line size \neq 1, 2, 4, 8, 16	4KB aligned address boundary
Posted memory write and invalidate	Cache line size = 1, 2, 4, 8	<i>n</i> th cache line boundary, where a cache line boundary is reached and less than 8 free Dwords of posted write buffer space remains
Posted memory write and invalidate	Cache line size = 16	16-Dword aligned address boundary

¹. The memory write disconnect control bit is located in the chip control register at offset 40h in configuration space.

4.5.5 Buffering Multiple Write Transactions

The 21150 continues to accept posted memory write transactions as long as space for at least 1 Dword of data in the posted write data buffer remains. If the posted write data buffer fills before the initiator terminates the write transaction, the 21150 returns a target disconnect to the initiator.

Delayed write transactions are posted as long as at least one open entry in the 21150 delayed transaction queue exists. Therefore, several posted and delayed write transactions can exist in data buffers at the same time.

See [Section 6.0](#) for information about how multiple posted and delayed write transactions are ordered.

4.5.6 Fast Back-to-Back Write Transactions

The 21150 can recognize and post fast back-to-back write transactions. When the 21150 cannot accept the second transaction because of buffer space limitations, it returns a target retry to the initiator.

When the 21150 has posted multiple write transactions, it can initiate fast back-to-back write transactions if the fast back-to-back enable bit is set in the command register for upstream write transactions, and in the bridge control register for downstream write transactions. The 21150 does not perform write combining or merging.

[Figure 8](#) shows how multiple memory write transactions can be posted and then initiated as fast back-to-back transactions on the target bus.

Figure 8. Multiple Memory Write Transactions Posted and Initiated as Fast Back-to-Back Transactions on the Target Bus

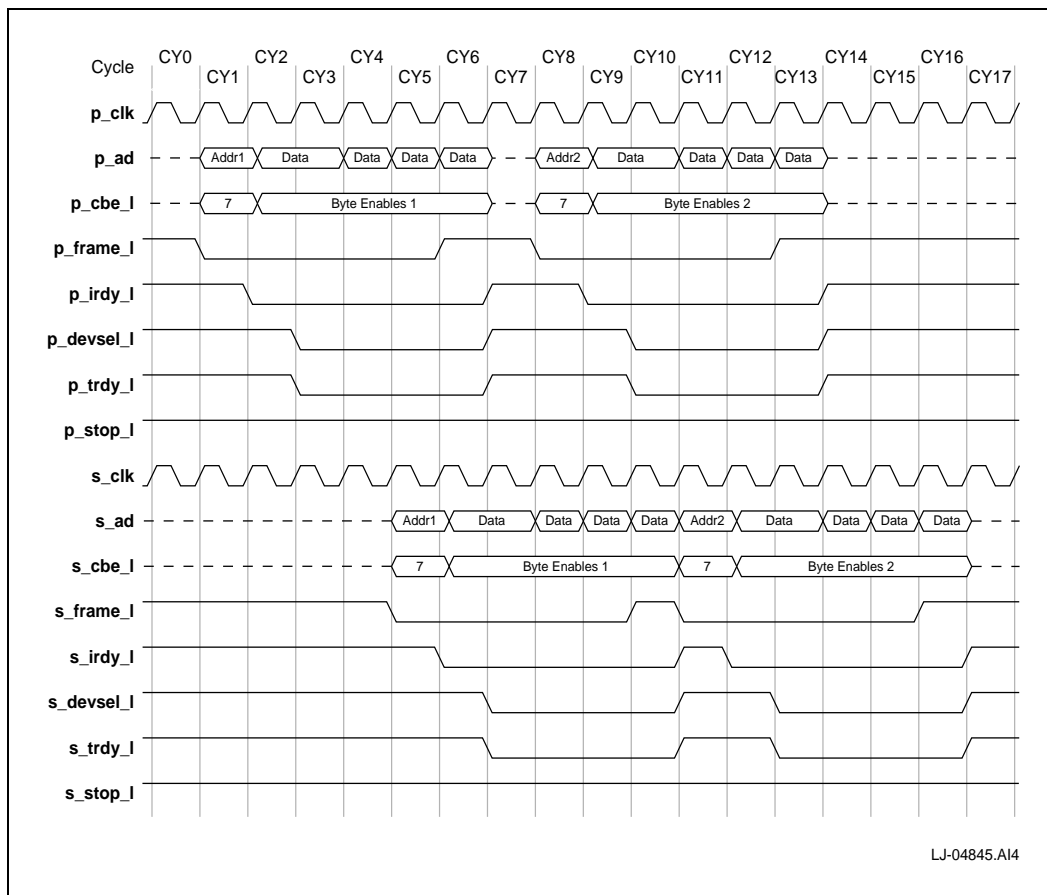

4.6 Read Transactions

Delayed read forwarding is used for all read transactions crossing the 21150.

Delayed read transactions are treated as either prefetchable or nonprefetchable.

Table 18 shows the read behavior, prefetchable or nonprefetchable, for each type of read operation.

Table 18. Read Transaction Prefetching (Sheet 1 of 2)

Type of Transaction	Read Behavior
I/O read	Prefetching never done
Configuration read	Prefetching never done

Table 18. Read Transaction Prefetching (Sheet 2 of 2)

Type of Transaction	Read Behavior
Memory read	Downstream: Prefetching used if address in prefetchable Upstream: Prefetching used if prefetch disable is off (default)
Memory read line	Prefetching always used
Memory read multiple	Prefetching always used

See [Section 5.3](#) for detailed information about prefetchable and nonprefetchable address spaces.

4.6.1 Prefetchable Read Transactions

A prefetchable read transaction is a read transaction where the 21150 performs speculative Dword reads, transferring data from the target before it is requested from the initiator. This behavior allows a prefetchable read transaction to consist of multiple data transfers. However, byte enable bits cannot be forwarded for all data phases as is done for the single data phase of the nonprefetchable read transaction. For prefetchable read transactions, the 21150 forces all byte enable bits to be turned on for all data phases.

Prefetchable behavior is used for memory read line and memory read multiple transactions, as well as for memory read transactions that fall into prefetchable memory space.

The amount of data that is prefetched depends on the type of transaction. The amount of prefetching may also be affected by the amount of free buffer space available in the 21150, and by any read address boundaries encountered.

Prefetching should not be used for those read transactions that have side effects in the target device, that is, control and status registers, FIFOs, and so on. The target device’s base address register or registers indicate if a memory address region is prefetchable.

4.6.2 Nonprefetchable Read Transactions

A nonprefetchable read transaction is a read transaction where the 21150 requests 1–and only 1–Dword from the target and disconnects the initiator after delivery of the first Dword of read data. Unlike prefetchable read transactions, the 21150 forwards the read byte enable information for the data phase.

Nonprefetchable behavior is used for I/O and configuration read transactions, as well as for memory read transactions that fall into nonprefetchable memory space.

If extra read transactions could have side effects, for example, when accessing a FIFO, use nonprefetchable read transactions to those locations. Accordingly, if it is important to retain the value of the byte enable bits during the data phase, use nonprefetchable read transactions. If these locations are mapped in memory space, use the memory read command and map the target into nonprefetchable (memory-mapped I/O) memory space to utilize nonprefetching behavior.

4.6.3 Read Prefetch Address Boundaries

The 21150 imposes internal read address boundaries on read prefetching. When a read transaction reaches one of these aligned address boundaries, the 21150 stops prefetching data, unless the target signals a target disconnect before the read prefetch boundary is reached. When the 21150 finishes transferring this read data to the initiator, it returns a target disconnect with the last data transfer, unless the initiator completes the transaction before all prefetched read data is delivered. Any leftover prefetched data is discarded.

Prefetchable read transactions in flow-through mode prefetch to the nearest aligned 4KB address boundary, or until the initiator deasserts FRAME#. [Section 4.6.6](#) describes flow-through mode during read operations.

[Table 19](#) shows the read prefetch address boundaries for read transactions during non-flow-through mode.

Table 19. Read Prefetch Address Boundaries

Type of Transaction	Address Space	Cache Line Size	Prefetch Aligned Address Boundary
Configuration read	—	—	1 Dword (no prefetch)
I/O read	—	—	1 Dword (no prefetch)
Memory read	Nonprefetchable	—	1 Dword (no prefetch)
Memory read	Prefetchable	CLS \neq 1, 2, 4, 8	16-Dword aligned address boundary
Memory read	Prefetchable	CLS = 1, 2, 4, 8	Cache line address boundary
Memory read line	—	CLS \neq 1, 2, 4, 8	16-Dword aligned address boundary
Memory read line	—	CLS = 1, 2, 4, 8	Cache line boundary
Memory read multiple	—	CLS \neq 1, 2, 4, 8	Queue full
Memory read multiple	—	CLS = 1, 2, 4, 8	Second cache line boundary

4.6.4 Delayed Read Requests

The 21150 treats all read transactions as delayed read transactions, which means that the read request from the initiator is posted into a delayed transaction queue. Read data from the target is placed in the read data queue directed toward the initiator bus interface and is transferred to the initiator when the initiator repeats the read transaction.

When the 21150 accepts a delayed read request, it first samples the read address, read bus command, and address parity. When IRDY# is asserted, the 21150 then samples the byte enable bits for the first data phase. This information is entered into the delayed transaction queue. The 21150 terminates the transaction by signaling a target retry to the initiator. Upon reception of the target retry, the initiator is required to continue to repeat the same read transaction until at least one data transfer is completed, or until a target response other than a target retry (target abort, or master abort) is received.

4.6.5 Delayed Read Completion with Target

When the delayed read request reaches the head of the delayed transaction queue, and all previously queued posted write transactions have been delivered, the 21150 arbitrates for the target bus and initiates the read transaction, using the exact read address and read command captured from the initiator during the initial delayed read request. If the read transaction is a nonprefetchable read, the 21150 drives the captured byte enable bits during the next cycle. If the transaction is a prefetchable read transaction, it drives all byte enable bits to 0 for all data phases. If the 21150 receives a target retry in response to the read transaction on the target bus, it continues to repeat the read transaction until at least one data transfer is completed, or until an error condition is encountered. If the transaction is terminated via normal master termination or target disconnect after at least one data transfer has been completed, the 21150 does not initiate any further attempts to read more data.

If the 21150 is unable to obtain read data from the target after 2^{24} attempts, the 21150 ceases further read attempts and returns a target abort to the initiator. The delayed transaction is removed from the delayed transaction queue. The 21150 also asserts `p_serr_1` if the primary SERR# enable bit is set in the command register. See [Section 7.4](#) for information on the assertion of `p_serr_1`.

Once the 21150 receives DEVSEL# and TRDY# from the target, it transfers the data read to the opposite direction read data queue, pointing toward the opposite interface, before terminating the transaction. For example, read data in response to a downstream read transaction initiated on the primary bus is placed in the upstream read data queue. The 21150 can accept 1 Dword of read data each PCI clock cycle; that is, no master wait states are inserted. The number of Dwords transferred during a delayed read transaction depends on the conditions given in [Table 19](#) (assuming no disconnect is received from the target).

4.6.6 Delayed Read Completion on Initiator Bus

When the transaction has been completed on the target bus, and the delayed read data is at the head of the read data queue, and all ordering constraints with posted write transactions have been satisfied, the 21150 transfers the data to the initiator when the initiator repeats the transaction. For memory read transactions, the 21150 aliases the memory read, memory read line, and memory read multiple bus commands when matching the bus command of the transaction to the bus command in the delayed transaction queue. The 21150 returns a target disconnect along with the transfer of the last Dword of read data to the initiator. If the initiator terminates the transaction before all read data has been transferred, the remaining read data left in data buffers is discarded.

[Figure 9](#) shows a nonprefetchable delayed read transaction.

Figure 9. Nonprefetchable Delayed Read Transaction

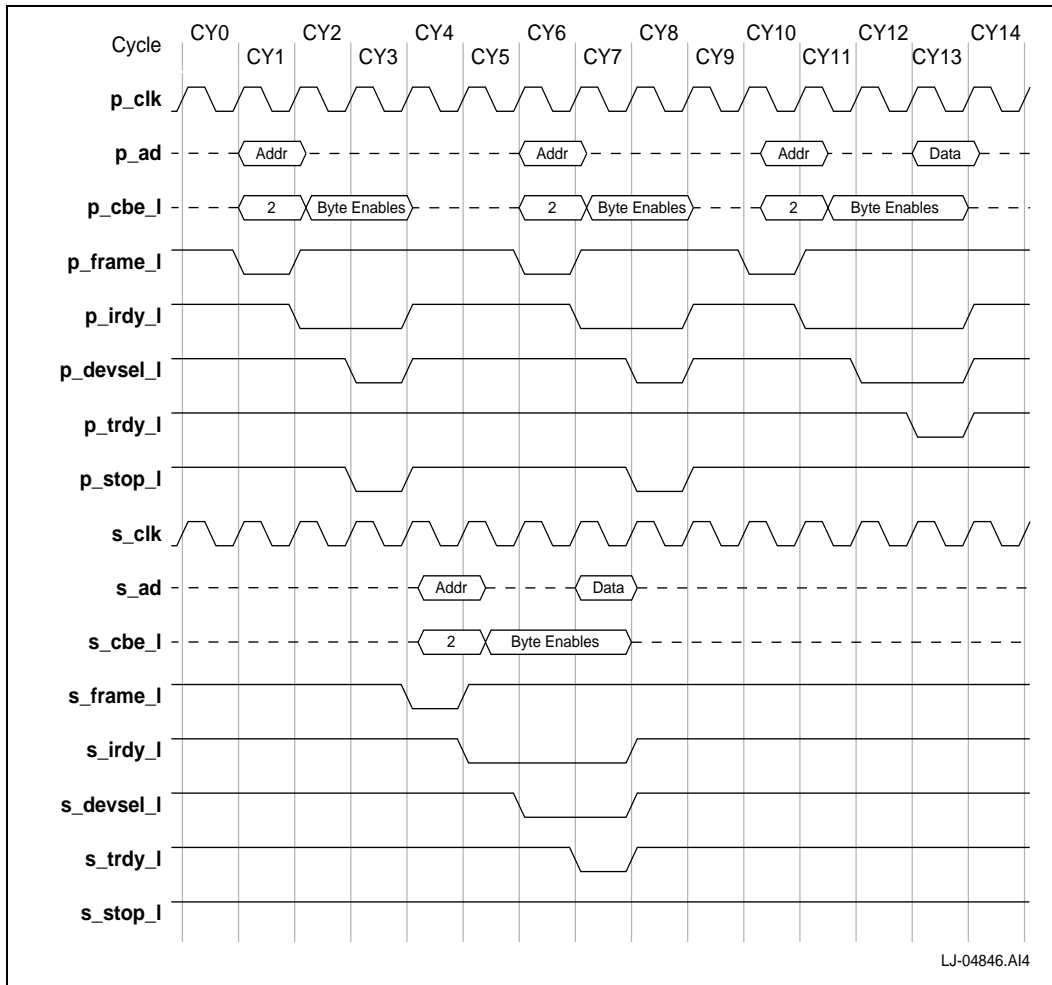
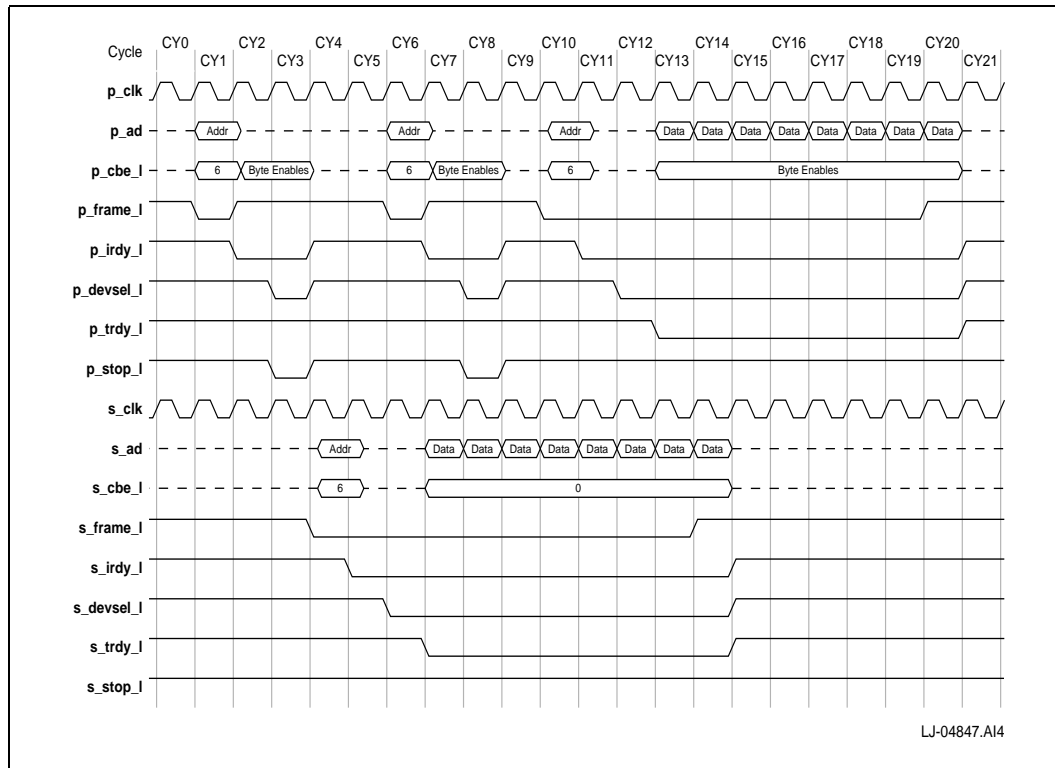

Figure 10 shows a prefetchable delayed read transaction.

Figure 10. Prefetchable Delayed Read Transaction



When the master repeats the transaction and starts transferring prefetchable read data from 21150 data buffers while the read transaction on the target bus is still in progress and before a read boundary is reached on the target bus, the read transaction starts operating in flow-through mode. Because data is flowing through the data buffers from the target to the initiator, long read bursts can then be sustained. In this case, the read transaction is allowed to continue until the initiator terminates the transaction, or until an aligned 4KB address boundary is reached, or until the buffer fills, whichever comes first. When the buffer empties, the 21150 reflects the stalled condition to the initiator by deasserting TRDY# until more read data is available; otherwise, the 21150 does not insert any target wait states. When the initiator terminates the transaction, the deassertion of FRAME# on the initiator bus is forwarded to the target bus. Any remaining read data is discarded.

Figure 11 shows a flow-through prefetchable read transaction.

Figure 11. Flow-Through Prefetchable Read Transaction

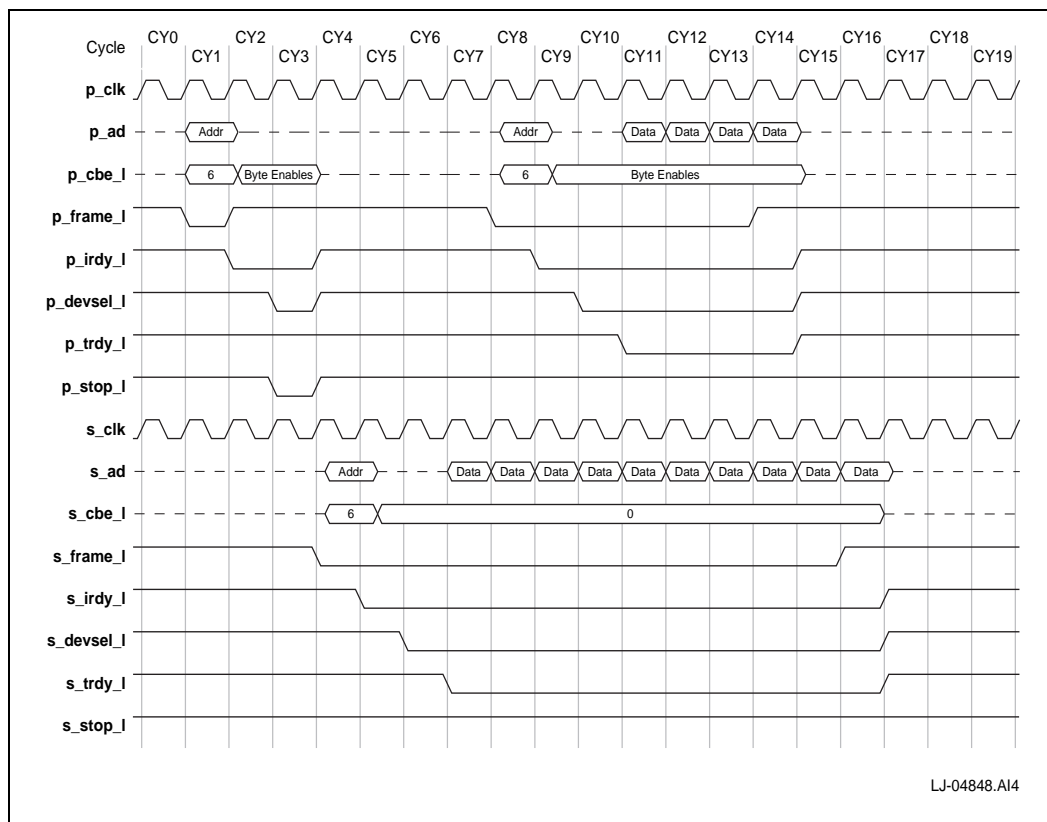

The 21150 implements a discard timer that starts counting when the delayed read completion is at the head of the delayed transaction queue, and the read data is at the head of the read data queue. The initial value of this timer can be set to one of two values, selectable through both the primary and secondary master timeout value bits in the bridge control register. If the initiator does not repeat the read transaction before the discard timer expires, the 21150 discards the read transaction and the read data from its queues. The 21150 also conditionally asserts `p_serr_l` (see [Section 7.4](#)).

The 21150 has the capability to post multiple delayed read requests, up to a maximum of three in each direction. If an initiator starts a read transaction that matches the address and read command of a read transaction that is already queued, the current read command is not posted as it is already contained in the delayed transaction queue.

See [Section 6.0](#) for a discussion of how delayed read transactions are ordered when crossing the 21150.

4.7 Configuration Transactions

Configuration transactions are used to initialize a PCI system. Every PCI device has a configuration space that is accessed by configuration commands. All 21150 registers are accessible in configuration space only.

In addition to accepting configuration transactions for initialization of its own configuration space, the 21150 also forwards configuration transactions for device initialization in hierarchical PCI systems, as well as for special cycle generation.

To support hierarchical PCI bus systems, two types of configuration transactions are specified: Type 0 and Type 1.

Type 0 configuration transactions are issued when the intended target resides on the same PCI bus as the initiator. A Type 0 configuration transaction is identified by the configuration command and the lowest 2 bits of the address set to 00b.

Type 1 configuration transactions are issued when the intended target resides on another PCI bus, or when a special cycle is to be generated on another PCI bus. A Type 1 configuration command is identified by the configuration command and the lowest 2 address bits set to 01b.

Figure 12 shows the address formats for Type 0 and Type 1 configuration transactions.

Figure 12. Configuration Transaction Address Formats

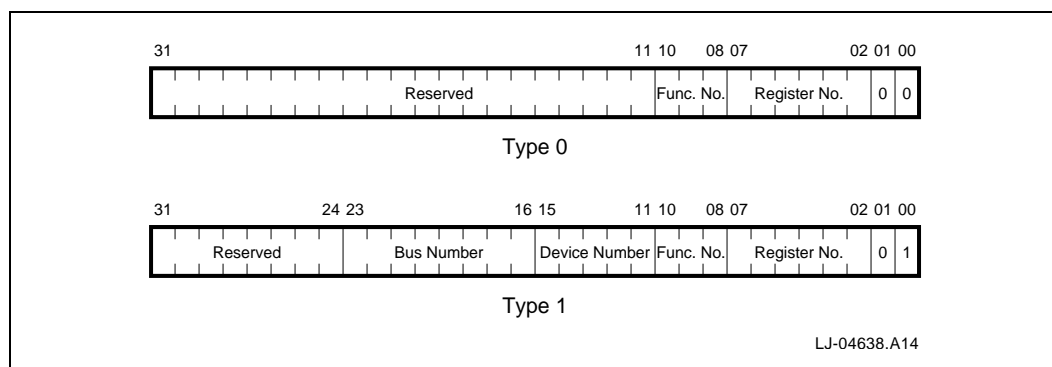

The register number is found in both Type 0 and Type 1 formats and gives the Dword address of the configuration register to be accessed. The function number is also included in both Type 0 and Type 1 formats and indicates which function of a multifunction device is to be accessed. For single-function devices, this value is not decoded. Type 1 configuration transaction addresses also include a 5-bit field designating the device number that identifies the device on the target PCI bus that is to be accessed. In addition, the bus number in Type 1 transactions specifies the PCI bus to which the transaction is targeted.

4.7.1 Type 0 Access to the 21150

The 21150 configuration space is accessed by a Type 0 configuration transaction on the primary interface. The 21150 configuration space cannot be accessed from the secondary bus. The 21150 responds to a Type 0 configuration transaction by asserting `p_devsel_1` when the following conditions are met during the address phase:

- The bus command is a configuration read or configuration write transaction.
- Low 2 address bits `p_ad<1:0>` must be 00b.
- Signal `p_idsel` must be asserted.

The function code is ignored because the 21150 is a single-function device.

The 21150 limits all configuration accesses to a single Dword data transfer and returns a target disconnect with the first data transfer if additional data phases are requested. Because read transactions to 21150 configuration space do not have side effects, all bytes in the requested Dword are returned, regardless of the value of the byte enable bits.

Type 0 configuration write and read transactions do not use 21150 data buffers; that is, these transactions are completed immediately, regardless of the state of the data buffers.

The 21150 ignores all Type 0 transactions initiated on the secondary interface.

4.7.2 Type 1 to Type 0 Translation

Type 1 configuration transactions are used specifically for device configuration in a hierarchical PCI bus system. A PCI-to-PCI bridge is the only type of device that should respond to a Type 1 configuration command. Type 1 configuration commands are used when the configuration access is intended for a PCI device that resides on a PCI bus other than the one where the Type 1 transaction is generated.

The 21150 performs a Type 1 to Type 0 translation when the Type 1 transaction is generated on the primary bus and is intended for a device attached directly to the secondary bus. The 21150 must convert the configuration command to a Type 0 format so that the secondary bus device can respond to it. Type 1 to Type 0 translations are performed only in the downstream direction; that is, the 21150 generates a Type 0 transaction only on the secondary bus, and never on the primary bus.

- The 21150 responds to a Type 1 configuration transaction and translates it into a Type 0 transaction on the secondary bus when the following conditions are met during the address phase:
 - The low 2 address bits on $p_ad<1:0>$ are 01b.
 - The bus number in address field $p_ad<23:16>$ is equal to the value in the secondary bus number register in 21150 configuration space.
 - The bus command on $p_cbe_1<3:0>$ is a configuration read or configuration write transaction.

When the 21150 translates the Type 1 transaction to a Type 0 transaction on the secondary interface, it performs the following translations to the address:

- Sets the low 2 address bits on $s_ad<1:0>$ to 00b.
- Decodes the device number and drives the bit pattern specified in [Table 20](#) on $s_ad<31:1>$ for the purpose of asserting the device's IDSEL signal.
- Sets $s_ad<15:11>$ to 0.
- Leaves unchanged the function number and register number fields.

The 21150 asserts a unique address line based on the device number. These address lines may be used as secondary bus IDSEL signals. The mapping of the address lines depends on the device number in the Type 1 address bits $p_ad<15:11>$. [Table 20](#) presents the mapping that the 21150 uses.

Table 20. Device Number to IDSEL s_ad Pin Mapping

Device Number	p_ad<15:11>	Secondary IDSEL s_ad<31:16>	s_ad Bit
0h	00000	0000 0000 0000 0001	16
1h	00001	0000 0000 0000 0010	17
2h	00010	0000 0000 0000 0100	18
3h	00011	0000 0000 0000 1000	19
4h	00100	0000 0000 0001 0000	20
5h	00101	0000 0000 0010 0000	21
6h	00110	0000 0000 0100 0000	22
7h	00111	0000 0000 1000 0000	23
8h	01000	0000 0001 0000 0000	24
9h	01001	0000 0010 0000 0000	25
Ah	01010	0000 0100 0000 0000	26
Bh	01011	0000 1000 0000 0000	27
Ch	01100	0001 000 0000 0000	28
Dh	01101	0010 0000 0000 0000	29
Eh	01110	0100 0000 0000 0000	30
Fh	01111	1000 000 0000 0000	31
10H–1Eh	10000–11110	0000 0000 0000 0000	—
1Fh	1111	Generate special cycle (p_ad<7:2> = 00h) 0000 0000 0000 0000 (p_ad<7:2> ≠ 00h)	—

The 21150 can assert up to 16 unique address lines to be used as IDSEL signals for up to 16 devices on the secondary bus, for device numbers ranging from 0 through 15. Because of electrical loading constraints of the PCI bus, more than 16 IDSEL signals should not be necessary. However, if device numbers greater than 15 are desired, some external method of generating IDSEL lines must be used, and no upper address bits are then asserted. The configuration transaction is still translated and passed from the primary bus to the secondary bus. If no IDSEL pin is asserted to a secondary device, the transaction ends in a master abort.

The 21150 forwards Type 1 to Type 0 configuration read or write transactions as delayed transactions. Type 1 to Type 0 configuration read or write transactions are limited to a single 32-bit data transfer.

4.7.3 Type 1 to Type 1 Forwarding

Type 1 to Type 1 transaction forwarding provides a hierarchical configuration mechanism when two or more levels of PCI-to-PCI bridges are used.

When the 21150 detects a Type 1 configuration transaction intended for a PCI bus downstream from the secondary bus, the 21150 forwards the transaction unchanged to the secondary bus. Ultimately, this transaction is translated to a Type 0 configuration command or to a special cycle transaction by a downstream PCI-to-PCI bridge. Downstream Type 1 to Type 1 forwarding occurs when the following conditions are met during the address phase:

- The low 2 address bits are equal to 01b.

- The bus number falls in the range defined by the lower limit (exclusive) in the secondary bus number register and the upper limit (inclusive) in the subordinate bus number register.
- The bus command is a configuration read or write transaction.

The 21150 also supports Type 1 to Type 1 forwarding of configuration write transactions upstream to support upstream special cycle generation. A Type 1 configuration command is forwarded upstream when the following conditions are met:

- The low 2 address bits are equal to 01b.
- The bus number falls outside the range defined by the lower limit (inclusive) in the secondary bus number register and the upper limit (inclusive) in the subordinate bus number register.
- The device number in address bits AD<15:11> is equal to 11111b.
- The function number in address bits AD<10:8> is equal to 111b.
- The bus command is a configuration write transaction.

The 21150 forwards Type 1 to Type 1 configuration write transactions as delayed transactions. Type 1 to Type 1 configuration write transactions are limited to a single data transfer.

4.7.4 Special Cycles

The Type 1 configuration mechanism is used to generate special cycle transactions in hierarchical PCI systems. Special cycle transactions are ignored by a PCI-to-PCI bridge acting as a target and are not forwarded across the bridge. Special cycle transactions can be generated from Type 1 configuration write transactions in either the upstream or the downstream direction.

The 21150 initiates a special cycle on the target bus when a Type 1 configuration write transaction is detected on the initiating bus and the following conditions are met during the address phase:

- The low 2 address bits on AD<1:0> are equal to 01b.
- The device number in address bits AD<15:11> is equal to 11111b.
- The function number in address bits AD<10:8> is equal to 111b.
- The register number in address bits AD<7:2> is equal to 000000b.
- The bus number is equal to the value in the secondary bus number register in configuration space for downstream forwarding or equal to the value in the primary bus number register in configuration space for upstream forwarding.
- The bus command on C/BE# is a configuration write command.

When the 21150 initiates the transaction on the target interface, the bus command is changed from configuration write to special cycle. The address and data are forwarded unchanged. Devices that use special cycles ignore the address and decode only the bus command. The data phase contains the special cycle message. The transaction is forwarded as a delayed transaction, but in this case the target response is not forwarded back (because special cycles result in a master abort). Once the transaction is completed on the target bus, through detection of the master abort condition, the 21150 responds with TRDY# to the next attempt of the configuration transaction from the initiator. If more than one data transfer is requested, the 21150 responds with a target disconnect operation during the first data phase.

4.8 Transaction Termination

This section describes how the 21150 returns transaction termination conditions back to the initiator.

The initiator can terminate transactions with one of the following types of termination:

- Normal termination
Normal termination occurs when the initiator deasserts FRAME# at the beginning of the last data phase, and deasserts IRDY# at the end of the last data phase in conjunction with either TRDY# or STOP# assertion from the target.
- Master abort
A master abort occurs when no target response is detected. When the initiator does not detect a DEVSEL# from the target within five clock cycles after asserting FRAME#, the initiator terminates the transaction with a master abort. If FRAME# is still asserted, the initiator deasserts FRAME# on the next cycle, and then deasserts IRDY# on the following cycle. IRDY# must be asserted in the same cycle in which FRAME# deasserts. If FRAME# is already deasserted, IRDY# can be deasserted on the next clock cycle following detection of the master abort condition.

The target can terminate transactions with one of the following types of termination:

- Normal termination—TRDY# and DEVSEL# asserted in conjunction with FRAME# deasserted and IRDY# asserted.
- Target retry—STOP# and DEVSEL# asserted without TRDY# during the first data phase. No data transfers occur during the transaction. This transaction must be repeated.
- Target disconnect with data transfer—STOP# and DEVSEL# asserted with TRDY#. Signals that this is the last data transfer of the transaction.
- Target disconnect without data transfer—STOP# and DEVSEL# asserted without TRDY# after previous data transfers have been made. Indicates that no more data transfers will be made during this transaction.
- Target abort—STOP# asserted without DEVSEL# and without TRDY#. Indicates that the target will never be able to complete this transaction. DEVSEL# must be asserted for at least one cycle during the transaction before the target abort is signaled.

4.8.1 Master Termination Initiated by the 21150

The 21150, as an initiator, uses normal termination if DEVSEL# is returned by the target within five clock cycles of the 21150's assertion of FRAME# on the target bus. As an initiator, the 21150 terminates a transaction when the following conditions are met:

- During a delayed write transaction, a single Dword is delivered.
- During a nonprefetchable read transaction, a single Dword is transferred from the target.
- During a prefetchable read transaction, a prefetch boundary is reached.
- For a posted write transaction, all write data for the transaction is transferred from 21150 data buffers to the target.
- For a burst transfer, with the exception of memory write and invalidate transactions, the master latency timer expires and the 21150's bus grant is deasserted.
- The target terminates the transaction with a retry, disconnect, or target abort.

If the 21150 is delivering posted write data when it terminates the transaction because the master latency timer expires, it initiates another transaction to deliver the remaining write data. The address of the transaction is updated to reflect the address of the current Dword to be delivered.

If the 21150 is prefetching read data when it terminates the transaction because the master latency timer expires, it does not repeat the transaction to obtain more data.

4.8.2 Master Abort Received by the 21150

If the 21150 initiates a transaction on the target bus and does not detect DEVSEL# returned by the target within five clock cycles of the 21150's assertion of FRAME#, the 21150 terminates the transaction with a master abort. The 21150 sets the received master abort bit in the status register corresponding to the target bus.

For delayed read and write transactions, when the master abort mode bit in the bridge control register is 0, the 21150 returns TRDY# on the initiator bus and, for read transactions, returns FFFF FFFFh as data.

When the master abort mode bit is 1, the 21150 returns target abort on the initiator bus. The 21150 also sets the signaled target abort bit in the register corresponding to the initiator bus.

[Figure 13](#) shows a delayed write transaction that is terminated with a master abort.

Figure 13. Delayed Write Transaction Terminated with Master Abort

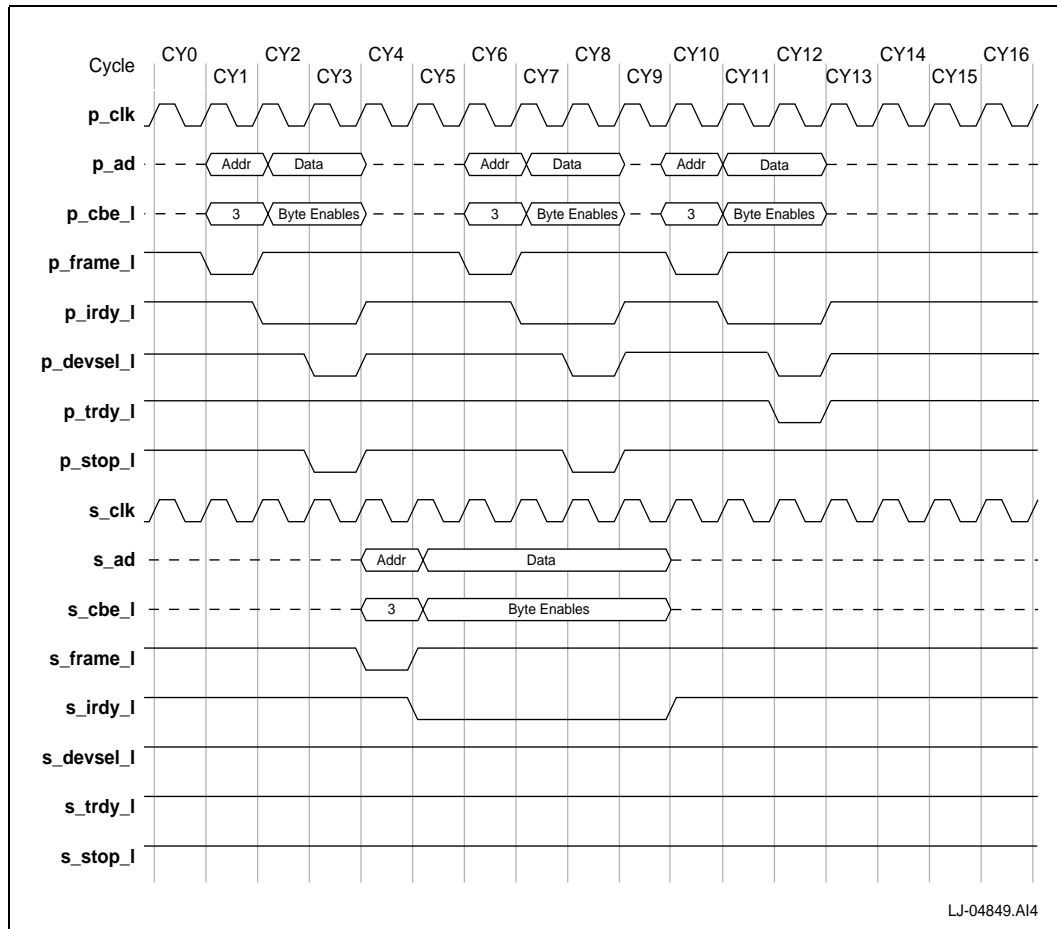

When a master abort is received in response to a posted write transaction, the 21150 discards the posted write data and makes no more attempts to deliver the data. The 21150 sets the received master abort bit in the status register when the master abort is received on the primary bus, or it sets the received master abort bit in the secondary status register when the master abort is received on the secondary interface.

When a master abort is detected in response to a posted write transaction, and the master abort mode bit is set, the 21150 also asserts p_serr_l if enabled by the SERR# enable bit in the command register and if not disabled by the device-specific p_serr_l disable bit for master abort during posted write transactions (that is, master abort mode = 1; SERR# enable bit = 1; and p_serr_l disable bit for master aborts = 0.)

Note: When the 21150 performs a Type 1 to special cycle translation, a master abort is the expected termination for the special cycle on the target bus. In this case, the master abort received bit is *not* set, and the Type 1 configuration transaction is disconnected after the first data phase.

4.8.3 Target Termination Received by the 21150

When the 21150 initiates a transaction on the target bus and the target responds with DEVSEL#, the target can end the transaction with one of the following types of termination:

- Normal termination (upon deassertion of FRAME#)
- Target retry
- Target disconnect
- Target abort

The 21150 handles these terminations in different ways, depending on the type of transaction being performed.

4.8.3.1 Delayed Write Target Termination Response

When the 21150 initiates a delayed write transaction, the type of target termination received from the target can be passed back to the initiator. Table 21 shows the 21150 response to each type of target termination that occurs during a delayed write transaction.

Table 21. 21150 Response to Delayed Write Target Termination

Target Termination	21150 Response
Normal	Return disconnect to initiator with first data transfer only if multiple data phases requested.
Target retry	Return target retry to initiator. Continue write attempts to target.
Target disconnect	Return disconnect to initiator with first data transfer only if multiple data phases requested.
Target abort	Return target abort to initiator. Set received target abort bit in target interface status register. Set signaled target abort bit in initiator interface status register.

The 21150 repeats a delayed write transaction until one of the following conditions is met:

- The 21150 completes at least one data transfer.
- The 21150 receives a master abort.
- The 21150 receives a target abort.
- The 21150 makes 2^{24} write attempts resulting in a response of target retry.

After the 21150 makes 2^{24} attempts of the same delayed write transaction on the target bus, the 21150 asserts p_serr_1 if the primary SERR# enable bit is set in the command register and the implementation-specific p_serr_1 disable bit for this condition is not set in the p_serr_1 event disable register. The 21150 stops initiating transactions in response to that delayed write transaction. The delayed write request is discarded. Upon a subsequent write transaction attempt by the initiator, the 21150 returns a target abort. See Section 7.4 for a description of system error conditions.

4.8.3.2 Posted Write Target Termination Response

When the 21150 initiates a posted write transaction, the target termination cannot be passed back to the initiator. [Table 22](#) shows the 21150 response to each type of target termination that occurs during a posted write transaction.

Table 22. 21150 Response to Posted Write Target Termination

Target Termination	21150 Response
Normal	No additional action.
Target retry	Repeat write transaction to target.
Target disconnect	Initiate write transaction to deliver remaining posted write data.
Target abort	Set received target abort bit in the target interface status register. Assert p_serr_l if enabled, and set the signaled system error bit in the primary status register.

Note that when a target retry or target disconnect is returned and posted write data associated with that transaction remains in the write buffers, the 21150 initiates another write transaction to attempt to deliver the rest of the write data. In the case of a target retry, the exact same address will be driven as for the initial write transaction attempt. If a target disconnect is received, the address that is driven on a subsequent write transaction attempt is updated to reflect the address of the current Dword. If the initial write transaction is a memory write and invalidate transaction, and a partial delivery of write data to the target is performed before a target disconnect is received, the 21150 uses the memory write command to deliver the rest of the write data because less than a cache line will be transferred in the subsequent write transaction attempt.

After the 21150 makes 2^{24} write transaction attempts and fails to deliver all the posted write data associated with that transaction, the 21150 asserts p_serr_l if the primary SERR# enable bit is set in the command register and the device-specific p_serr_l disable bit for this condition is not set in the p_serr_l event disable register. The write data is discarded. See [Section 7.4](#) for a discussion of system error conditions.

4.8.3.3 Delayed Read Target Termination Response

When the 21150 initiates a delayed read transaction, the abnormal target responses can be passed back to the initiator. Other target responses depend on how much data the initiator requests. [Table 23](#) shows the 21150 response to each type of target termination that occurs during a delayed read transaction.

Table 23. 21150 Response to Delayed Read Target Termination (Sheet 1 of 2)

Target Termination	21150 Response
Normal	If prefetchable, target disconnect only if initiator requests more data than read from target. If nonprefetchable, target disconnect on first data phase.
Target retry	Reinitiate read transaction to target.
Target disconnect	If initiator requests more data than read from target, return target disconnect to initiator.

Table 23. 21150 Response to Delayed Read Target Termination (Sheet 2 of 2)

Target Termination	21150 Response
Target abort	Return target abort to initiator. Set received target abort bit in the target interface status register. Set signaled target abort bit in the initiator interface status register.

Figure 14 shows a delayed read transaction that is terminated with a target abort.

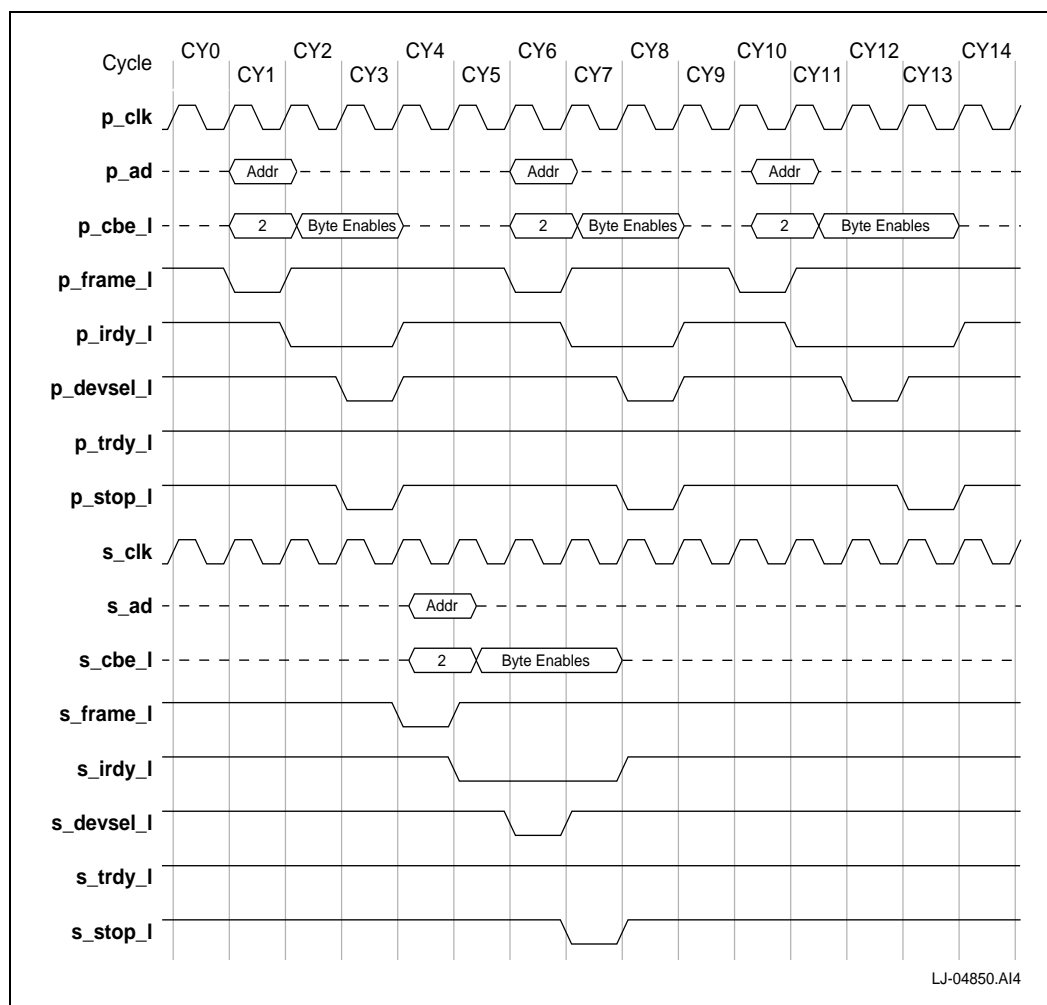
Figure 14. Delayed Read Transaction Terminated with Target Abort

The 21150 repeats a delayed read transaction until one of the following conditions is met:

- The 21150 completes at least one data transfer.
- The 21150 receives a master abort.
- The 21150 receives a target abort.
- The 21150 makes 2^{24} read attempts resulting in a response of target retry.

After the 21150 makes 2^{24} attempts of the same delayed read transaction on the target bus, the 21150 asserts p_serr_1 if the primary SERR# enable bit is set in the command register and the implementation-specific p_serr_1 disable bit for this condition is not set in the p_serr_1 event disable register. The 21150 stops initiating transactions in response to that delayed read transaction. The delayed read request is discarded. Upon a subsequent read transaction attempt by the initiator, the 21150 returns a target abort. See [Section 7.4](#) for a description of system error conditions.

4.8.4 Target Termination Initiated by the 21150

The 21150 can return a target retry, target disconnect, or target abort to an initiator for reasons other than detection of that condition at the target interface.

4.8.4.1 Target Retry

The 21150 returns a target retry to the initiator when it cannot accept write data or return read data as a result of internal conditions. The 21150 returns a target retry to an initiator when any of the following conditions is met:

- For delayed write transactions:
 - The transaction is being entered into the delayed transaction queue.
 - The transaction has already been entered into the delayed transaction queue, but target response has not yet been received.
 - Target response has been received but has not progressed to the head of the return queue.
 - The delayed transaction queue is full, and the transaction cannot be queued.
 - A transaction with the same address and command has been queued.
 - A locked sequence is being propagated across the 21150, and the write transaction is not a locked transaction.
- For delayed read transactions:
 - The transaction is being entered into the delayed transaction queue.
 - The read request has already been queued, but read data is not yet available.
 - Data has been read from the target, but it is not yet at the head of the read data queue, or a posted write transaction precedes it.
 - The delayed transaction queue is full, and the transaction cannot be queued.
 - A delayed read request with the same address and bus command has already been queued.
 - A locked sequence is being propagated across the 21150, and the read transaction is not a locked transaction.
 - The 21150 is currently discarding previously prefetched read data.
- For posted write transactions:
 - The posted write data buffer does not have enough space for address and at least 8 Dwords of write data.
 - A locked sequence is being propagated across the 21150, and the write transaction is not a locked transaction.

When a target retry is returned to the initiator of a delayed transaction, the initiator must repeat the transaction with the same address and bus command as well as the data if this is a write transaction, within the time frame specified by the master timeout value; otherwise, the transaction is discarded from the 21150 buffers.

4.8.4.2 Target Disconnect

The 21150 returns a target disconnect to an initiator when one of the following conditions is met:

- The 21150 hits an internal address boundary
- The 21150 cannot accept any more write data
- The 21150 has no more read data to deliver

See [Section 4.5.4](#) for a description of write address boundaries, and [Section 4.6.3](#) for a description of read address boundaries.

4.8.4.3 Target Abort

The 21150 returns a target abort to an initiator when one of the following conditions is met:

- The 21150 is returning a target abort from the intended target.
- The 21150 is unable to obtain delayed read data from the target or to deliver delayed write data to the target after 2^{24} attempts.

When the 21150 returns a target abort to the initiator, it sets the signaled target abort bit in the status register corresponding to the initiator interface.

5.0 Address Decoding

The 21150 uses three address ranges that control I/O and memory transaction forwarding. These address ranges are defined by base and limit address registers in the 21150 configuration space.

This chapter describes these address ranges, as well as ISA-mode and VGA-addressing support.

5.1 Address Ranges

The 21150 uses the following address ranges that determine which I/O and memory transactions are forwarded from the primary PCI bus to the secondary PCI bus, and from the secondary bus to the primary bus:

- One 32-bit I/O address range
- One 32-bit memory-mapped I/O (nonprefetchable memory)
- One 64-bit prefetchable memory address range

Transactions falling within these ranges are forwarded downstream from the primary PCI bus to the secondary PCI bus. Transactions falling outside these ranges are forwarded upstream from the secondary PCI bus to the primary PCI bus.

The 21150 uses a flat address space; that is, it does not perform any address translations. The address space has no “gaps”—addresses that are not marked for downstream forwarding are always forwarded upstream.

5.2 I/O Address Decoding

The 21150 uses the following mechanisms that are defined in the 21150 configuration space to specify the I/O address space for downstream and upstream forwarding:

- I/O base and limit address registers
- The ISA enable bit
- The VGA mode bit
- The VGA snoop bit

This section provides information on the I/O address registers and ISA mode. [Section 5.4](#) provides information on the VGA modes.

To enable downstream forwarding of I/O transactions, the I/O enable bit must be set in the command register in 21150 configuration space. If the I/O enable bit is not set, all I/O transactions initiated on the primary bus are ignored. To enable upstream forwarding of I/O transactions, the master enable bit must be set in the command register. If the master enable bit is not set, the 21150 ignores all I/O and memory transactions initiated on the secondary bus. Setting the master enable bit also allows upstream forwarding of memory transactions.

Caution: If any 21150 configuration state affecting I/O transaction forwarding is changed by a configuration write operation on the primary bus at the same time that I/O transactions are ongoing on the secondary bus, the 21150 response to the secondary bus I/O transactions is not predictable. Configure the I/O base and limit address registers, ISA enable bit, VGA mode bit, and VGA snoop bit before setting the I/O enable and master enable bits, and change them subsequently only when the primary and secondary PCI buses are idle.

5.2.1 I/O Base and Limit Address Registers

The 21150 implements one set of I/O base and limit address registers in configuration space that define an I/O address range for downstream forwarding. The 21150 supports 32-bit I/O addressing, which allows I/O addresses downstream of the 21150 to be mapped anywhere in a 4GB I/O address space.

I/O transactions with addresses that fall inside the range defined by the I/O base and limit registers are forwarded downstream from the primary PCI bus to the secondary PCI bus. I/O transactions with addresses that fall outside this range are forwarded upstream from the secondary PCI bus to the primary PCI bus.

The I/O range can be turned off by setting the I/O base address to a value greater than that of the I/O limit address. When the I/O range is turned off, all I/O transactions are forwarded upstream, and no I/O transactions are forwarded downstream.

Figure 15 illustrates transaction forwarding within and outside the I/O address range.

Figure 15. I/O Transaction Forwarding Using Base and Limit Addresses

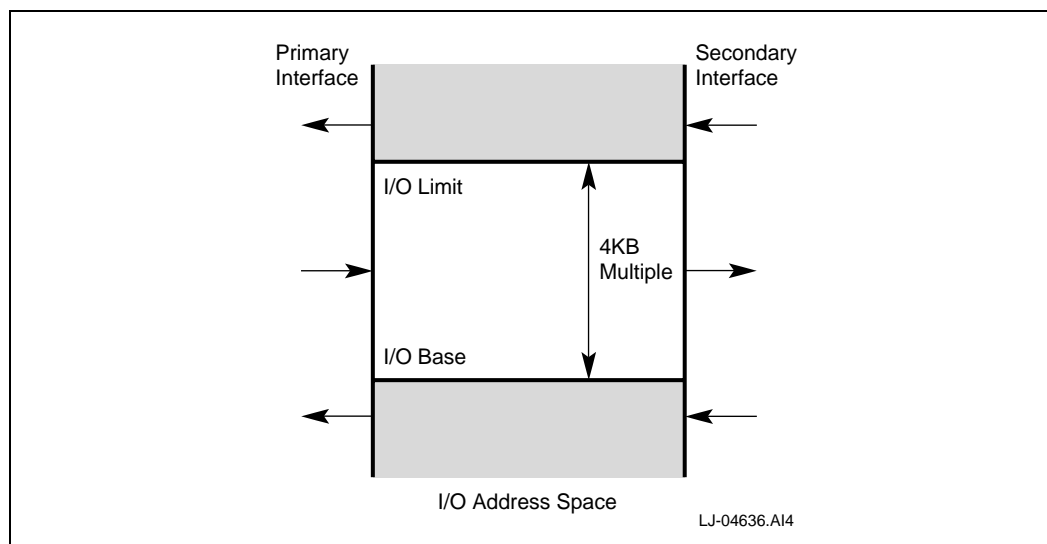

The 21150 I/O range has a minimum granularity of 4KB and is aligned on a 4KB boundary. The maximum I/O range is 4GB in size.

The I/O base register consists of an 8-bit field at configuration address 1Ch, and a 16-bit field at address 30h. The top 4 bits of the 8-bit field define bits <15:12> of the I/O base address. The bottom 4 bits read only as 1h to indicate that the 21150 supports 32-bit I/O addressing. Bits <11:0> of the base address are assumed to be 0, which naturally aligns the base address to a 4KB boundary.

The 16 bits contained in the I/O base upper 16 bits register at configuration offset 30h define AD<31:16> of the I/O base address. All 16 bits are read/write. After primary bus reset or chip reset, the value of the I/O base address is initialized to 0000 0000h.

The I/O limit register consists of an 8-bit field at configuration offset 1Dh and a 16-bit field at offset 32h. The top 4 bits of the 8-bit field define bits <15:12> of the I/O limit address. The bottom 4 bits read only as 1h to indicate that 32-bit I/O addressing is supported. Bits <11:0> of the limit address are assumed to be FFFh, which naturally aligns the limit address to the top of a 4KB I/O address block. The 16 bits contained in the I/O limit upper 16 bits register at configuration offset 32h define AD<31:16> of the I/O limit address. All 16 bits are read/write. After primary bus reset or chip reset, the value of the I/O limit address is reset to 0000 0FFFh.

Note: The initial states of the I/O base and I/O limit address registers define an I/O range of 0000 0000h to 0000 0FFFh, which is the bottom 4KB of I/O space. Write these registers with their appropriate values before setting either the I/O enable bit or the master enable bit in the command register in configuration space.

5.2.2 ISA Mode

The 21150 supports ISA mode by providing an ISA enable bit in the bridge control register in configuration space. ISA mode modifies the response of the 21150 inside the I/O address range in order to support mapping of I/O space in the presence of an ISA bus in the system. This bit only affects the response of the 21150 when the transaction falls inside the address range defined by the I/O base and limit address registers, and only when this address also falls inside the first 64KB of I/O space (address bits <31:16> are 0000h).

When the ISA enable bit is set, the 21150 does not forward downstream any I/O transactions addressing the top 768 bytes of each aligned 1KB block. Only those transactions addressing the bottom 256 bytes of an aligned 1KB block inside the base and limit I/O address range are forwarded downstream. Transactions above the 64KB I/O address boundary are forwarded as defined by the address range defined by the I/O base and limit registers.

Accordingly, if the ISA enable bit is set, the 21150 forwards upstream those I/O transactions addressing the top 768 bytes of each aligned 1KB block within the first 64KB of I/O space. The master enable bit in the command configuration register must also be set to enable upstream forwarding. All other I/O transactions initiated on the secondary bus are forwarded upstream only if they fall outside the I/O address range.

When the ISA enable bit is set, devices downstream of the 21150 can have I/O space mapped into the first 256 bytes of each 1KB chunk below the 64KB boundary, or anywhere in I/O space above the 64KB boundary.

Figure 16 illustrates I/O forwarding when the ISA enable bit is set.

Figure 16. I/O Transaction Forwarding in ISA Mode

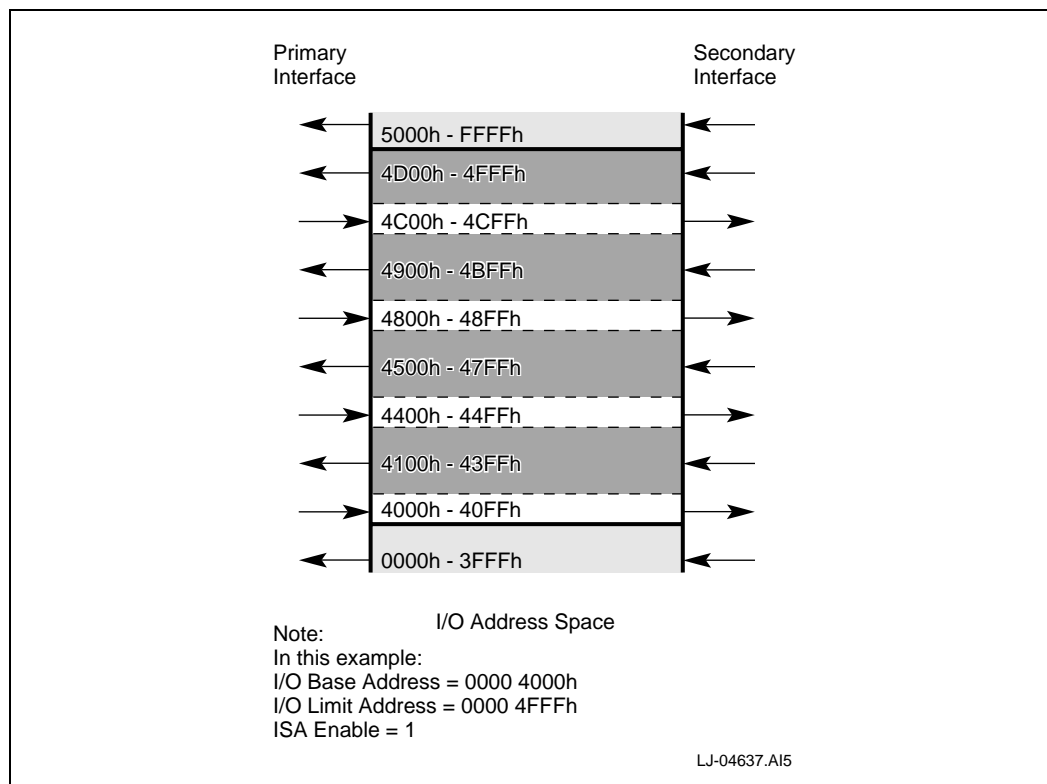

5.3 Memory Address Decoding

The 21150 has three mechanisms for defining memory address ranges for forwarding of memory transactions:

- Memory-mapped I/O base and limit address registers
- Prefetchable memory base and limit address registers
- VGA mode

This section describes the first two mechanisms. [Section 5.4.1](#) describes VGA mode.

To enable downstream forwarding of memory transactions, the memory enable bit must be set in the command register in 21150 configuration space. To enable upstream forwarding of memory transactions, the master enable bit must be set in the command register. Setting the master enable bit also allows upstream forwarding of I/O transactions.

Caution: If any 21150 configuration state affecting memory transaction forwarding is changed by a configuration write operation on the primary bus at the same time that memory transactions are ongoing on the secondary bus, 21150 response to the secondary bus memory transactions is not predictable. Configure the memory-mapped I/O base and limit address registers, prefetchable memory base and limit address registers, and VGA mode bit before setting the memory enable and

master enable bits, and change them subsequently only when the primary and secondary PCI buses are idle.

5.3.1 Memory-Mapped I/O Base and Limit Address Registers

Memory-mapped I/O is also referred to as nonprefetchable memory. Memory addresses that cannot automatically be prefetched but that can conditionally prefetch based on command type should be mapped into this space. Read transactions to nonprefetchable space may exhibit side effects; this space may have non-memory-like behavior. The 21150 prefetches in this space only if the memory read line or memory read multiple commands are used; transactions using the memory read command are limited to a single data transfer.

The memory-mapped I/O base address and memory-mapped I/O limit address registers define an address range that the 21150 uses to determine when to forward memory commands. The 21150 forwards a memory transaction from the primary to the secondary interface if the transaction address falls within the memory-mapped I/O address range. The 21150 ignores memory transactions initiated on the secondary interface that fall into this address range. Any transactions that fall outside this address range are ignored on the primary interface and are forwarded upstream from the secondary interface (provided that they do not fall into the prefetchable memory range or are not forwarded downstream by the VGA mechanism).

The memory-mapped I/O range supports 32-bit addressing only. The *PCI-to-PCI Bridge Architecture Specification* does not provide for 64-bit addressing in the memory-mapped I/O space. The memory-mapped I/O address range has a granularity and alignment of 1MB. The maximum memory-mapped I/O address range is 4GB.

The memory-mapped I/O address range is defined by a 16-bit memory-mapped I/O base address register at configuration offset 20h and by a 16-bit memory-mapped I/O limit address register at offset 22h. The top 12 bits of each of these registers correspond to bits <31:20> of the memory address. The low 4 bits are hardwired to 0. The low 20 bits of the memory-mapped I/O base address are assumed to be 0 0000h, which results in a natural alignment to a 1MB boundary. The low 20 bits of the memory-mapped I/O limit address are assumed to be F FFFFh, which results in an alignment to the top of a 1MB block.

Note: The initial state of the memory-mapped I/O base address register is 0000 0000h. The initial state of the memory-mapped I/O limit address register is 000F FFFFh. Note that the initial states of these registers define a memory-mapped I/O range at the bottom 1MB block of memory. Write these registers with their appropriate values before setting either the memory enable bit or the master enable bit in the command register in configuration space.

To turn off the memory-mapped I/O address range, write the memory-mapped I/O base address register with a value greater than that of the memory-mapped I/O limit address register.

Figure 17 shows how transactions are forwarded using both the memory-mapped I/O range and the prefetchable memory range.

Figure 17. Memory Transaction Forwarding Using Base and Limit Registers

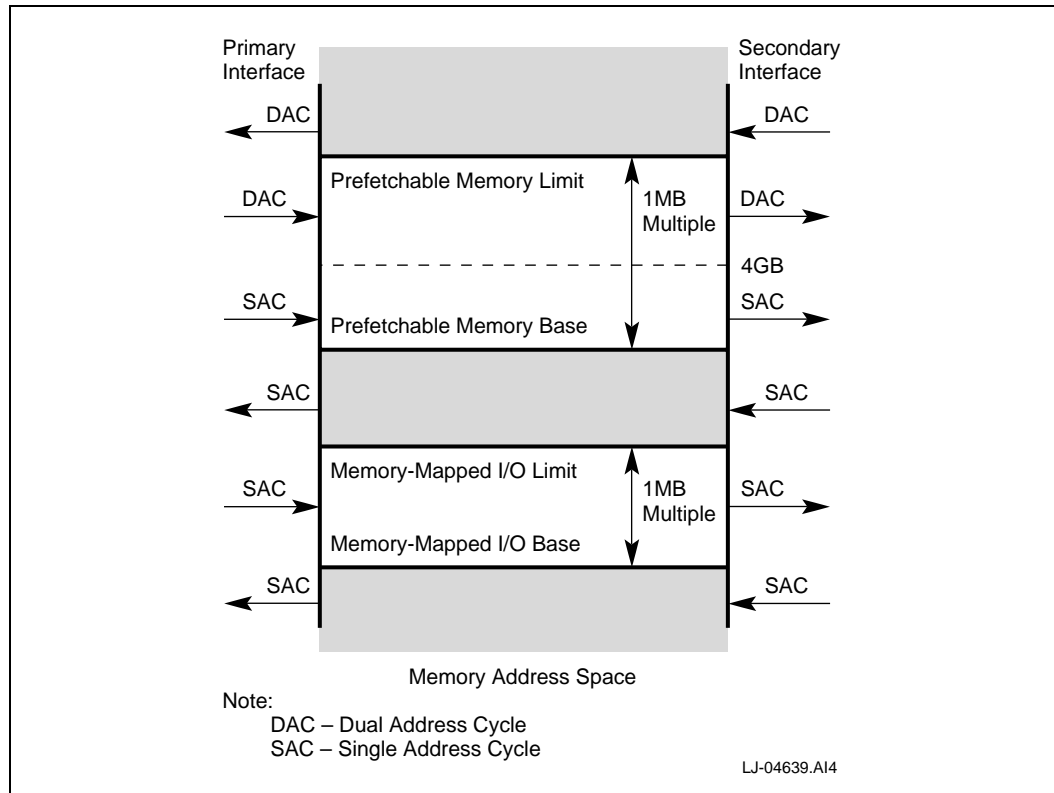

5.3.2 Prefetchable Memory Base and Limit Address Registers

Locations accessed in the prefetchable memory address range must have true memory-like behavior and must not exhibit side effects when read. This means that extra reads to a prefetchable memory location must have no side effects. The 21150 prefetches for all types of memory read commands in this address space.

The prefetchable memory base address and prefetchable memory limit address registers define an address range that the 21150 uses to determine when to forward memory commands. The 21150 forwards a memory transaction from the primary to the secondary interface if the transaction address falls within the prefetchable memory address range. The 21150 ignores memory transactions initiated on the secondary interface that fall into this address range. The 21150 does not respond to any transactions that fall outside this address range on the primary interface and forwards those transactions upstream from the secondary interface (provided that they do not fall into the memory-mapped I/O range or are not forwarded by the VGA mechanism).

The prefetchable memory range supports 64-bit addressing and provides additional registers to define the upper 32 bits of the memory address range, the prefetchable memory base address upper 32 bits register, and the prefetchable memory limit address upper 32 bits register. For address comparison, a single address cycle (32-bit address) prefetchable memory transaction is treated like a 64-bit address transaction where the upper 32 bits of the address are equal to 0. This upper 32-bit value of 0 is compared to the prefetchable memory base address upper 32 bits register and the prefetchable memory limit address upper 32 bits register. The prefetchable memory base address upper 32 bits register must be 0 in order to pass any single address cycle transactions downstream. [Section 5.3.3](#) further describes 64-bit addressing support.

The prefetchable memory address range has a granularity and alignment of 1MB. The maximum memory address range is 4GB when 32-bit addressing is used, and 2^{64} bytes when 64-bit addressing is used.

The prefetchable memory address range is defined by a 16-bit prefetchable memory base address register at configuration offset 24h and by a 16-bit prefetchable memory limit address register at offset 28h. The top 12 bits of each of these registers correspond to bits <31:20> of the memory address. The low 4 bits are hardwired to 1h, indicating 64-bit address support. The low 20 bits of the prefetchable memory base address are assumed to be 0 0000h, which results in a natural alignment to a 1MB boundary. The low 20 bits of the prefetchable memory limit address are assumed to be F FFFFh, which results in an alignment to the top of a 1MB block.

Note: The initial state of the prefetchable memory base address register is 0000 0000h. The initial state of the prefetchable memory limit address register is 000F FFFFh. Note that the initial states of these registers define a prefetchable memory range at the bottom 1MB block of memory. Write these registers with their appropriate values before setting either the memory enable bit or the master enable bit in the command register in configuration space.

To turn off the prefetchable memory address range, write the prefetchable memory base address register with a value greater than that of the prefetchable memory limit address register. The entire base value must be greater than the entire limit value, meaning that the upper 32 bits must be considered. Therefore, to disable the address range, the upper 32 bits registers can both be set to the same value, while the lower base register is set greater than the lower limit register; otherwise, the upper 32-bit base must be greater than the upper 32-bit limit.

5.3.3 Prefetchable Memory 64-Bit Addressing Registers

The 21150 supports 64-bit memory address decoding for forwarding of dual address memory transactions. The dual address cycle is used to support 64-bit addressing. The first address phase of a dual address transaction contains the low 32 address bits, and the second address phase contains the high 32 address bits. During a dual address cycle transaction, the upper 32 bits must never be 0—use the single address cycle commands for transactions addressing the first 4GB of memory space.

The 21150 implements the prefetchable memory base address upper 32 bits register and the prefetchable memory limit address upper 32 bits register to define a prefetchable memory address range greater than 4GB. The prefetchable address space can then be defined in three different ways:

- Residing entirely in the first 4GB of memory
- Residing entirely above the first 4GB of memory
- Crossing the first 4GB memory boundary

If the prefetchable memory space on the secondary interface resides entirely in the first 4GB of memory, both upper 32 bits registers must be set to 0. The 21150 ignores all dual address cycle transactions initiated on the primary interface and forwards all dual address transactions initiated on the secondary interface upstream.

If the secondary interface prefetchable memory space resides entirely above the first 4GB of memory, both the prefetchable memory base address upper 32 bits register and the prefetchable memory limit address upper 32 bits register must be initialized to nonzero values. The 21150 ignores all single address memory transactions initiated on the primary interface and forwards all single address memory transactions initiated on the secondary interface upstream (unless they fall

within the memory-mapped I/O or VGA memory range). A dual address memory transaction is forwarded downstream from the primary interface if it falls within the address range defined by the prefetchable memory base address, prefetchable memory base address upper 32 bits, prefetchable memory limit address, and prefetchable memory limit address upper 32 bits registers. If the dual address transaction initiated on the secondary interface falls outside this address range, it is forwarded upstream to the primary interface. The 21150 does not respond to a dual address transaction initiated on the primary interface that falls outside this address range, or to a dual address transaction initiated on the secondary interface that falls within the address range.

If the secondary interface prefetchable memory space straddles the first 4GB address boundary, the prefetchable memory base address upper 32 bits register is set to 0, while the prefetchable memory limit address upper 32 bits register is initialized to a nonzero value. Single address cycle memory transactions are compared to the prefetchable memory base address register only. A transaction initiated on the primary interface is forwarded downstream if the address is greater than or equal to the base address. A transaction initiated on the secondary interface is forwarded upstream if the address is less than the base address. Dual address transactions are compared to the prefetchable memory limit address and the prefetchable memory limit address upper 32 bits registers. If the address of the dual address transaction is less than or equal to the limit, the transaction is forwarded downstream from the primary interface and is ignored on the secondary interface. If the address of the dual address transaction is greater than this limit, the transaction is ignored on the primary interface and is forwarded upstream from the secondary interface.

The prefetchable memory base address upper 32 bits register is located at configuration Dword offset 28h, and the prefetchable memory limit address upper 32 bits register is located at configuration Dword offset 2Ch. Both registers are reset to 0. See [Figure 17](#) for an illustration of how transactions are forwarded using both the memory-mapped I/O range and the prefetchable memory range.

5.4 VGA Support

The 21150 provides two modes for VGA support:

- VGA mode, supporting VGA-compatible addressing
- VGA snoop mode, supporting VGA palette forwarding

5.4.1 VGA Mode

When a VGA-compatible device exists downstream from the 21150, set the VGA mode bit in the bridge control register in configuration space to enable VGA mode. When the 21150 is operating in VGA mode, it forwards downstream those transactions addressing the VGA frame buffer memory and VGA I/O registers, regardless of the values of the 21150 base and limit address registers. The 21150 ignores transactions initiated on the secondary interface addressing these locations.

The VGA frame buffer consists of the following memory address range:

000A 0000h—000B FFFFh

Read transactions to frame buffer memory are treated as nonprefetchable. The 21150 requests only a single data transfer from the target, and read byte enable bits are forwarded to the target bus.

The VGA I/O addresses consist of the following I/O addresses:

- 3B0h–3BBh
- 3C0h–3DFh

These I/O addresses are aliased every 1KB throughout the first 64KB of I/O space. This means that address bits <15:10> are not decoded and can be any value, while address bits <31:16> must be all 0s.

VGA BIOS addresses starting at C0000h are not decoded in VGA mode.

5.4.2 VGA Snoop Mode

The 21150 provides VGA snoop mode, allowing for VGA palette write transactions to be forwarded downstream. This mode is used when a graphics device downstream from the 21150 needs to snoop or respond to VGA palette write transactions. To enable the mode, set the VGA snoop bit in the command register in configuration space.

Note that the 21150 claims VGA palette write transactions by asserting DEVSEL# in VGA snoop mode.

When the VGA snoop bit is set, the 21150 forwards downstream transactions with the following I/O addresses:

- 3C6h
- 3C8h
- 3C9h

Note that these addresses are also forwarded as part of the VGA compatibility mode previously described. Again, address bits <15:10> are not decoded, while address bits <31:16> must be equal to 0, which means that these addresses are aliased every 1KB throughout the first 64KB of I/O space.

Note: If both the VGA mode bit and the VGA snoop bit are set, the 21150 behaves in the same way as if only the VGA mode bit were set.

6.0 Transaction Ordering

To maintain data coherency and consistency, the 21150 complies with the ordering rules set forth in the *PCI Local Bus Specification, Revision 2.1*, for transactions crossing the bridge.

This chapter describes the ordering rules that control transaction forwarding across the 21150. For a more detailed discussion of transaction ordering, see Appendix E of the *PCI Local Bus Specification, Revision 2.1*.

6.1 Transactions Governed by Ordering Rules

Ordering relationships are established for the following classes of transactions crossing the 21150:

- Posted write transactions, comprised of memory write and memory write and invalidate transactions
Posted write transactions complete at the source before they complete at the destination; that is, data is written into intermediate data buffers before it reaches the target.
- Delayed write request transactions, comprised of I/O write and configuration write transactions
Delayed write requests are terminated by target retry on the initiator bus and are queued in the delayed transaction queue. A delayed write transaction must complete on the target bus before it completes on the initiator bus.
- Delayed write completion transactions, also comprised of I/O write and configuration write transactions
Delayed write completion transactions have been completed on the target bus, and the target response is queued in the 21150 buffers. A delayed write completion transaction proceeds in the direction opposite that of the original delayed write request; that is, a delayed write completion transaction proceeds from the target bus to the initiator bus.
- Delayed read request transactions, comprised of all memory read, I/O read, and configuration read transactions
Delayed read requests are terminated by target retry on the initiator bus and are queued in the delayed transaction queue.
- Delayed read completion transactions, comprised of all memory read, I/O read, and configuration read transactions
Delayed read completion transactions have been completed on the target bus, and the read data has been queued in the 21150 read data buffers. A delayed read completion transaction proceeds in the direction opposite that of the original delayed read request; that is, a delayed read completion transaction proceeds from the target bus to the initiator bus.

The 21150 does not combine or merge write transactions:

- The 21150 does not combine separate write transactions into a single write transaction—this optimization is best implemented in the originating master.
- The 21150 does not merge bytes on separate masked write transactions to the same Dword address—this optimization is also best implemented in the originating master.
- The 21150 does not collapse sequential write transactions to the same address into a single write transaction—the *PCI Local Bus Specification* does not permit this combining of transactions.

6.2 General Ordering Guidelines

Independent transactions on the primary and secondary buses have a relationship only when those transactions cross the 21150.

The following general ordering guidelines govern transactions crossing the 21150:

- The ordering relationship of a transaction with respect to other transactions is determined when the transaction completes, that is, when a transaction ends with a termination other than target retry.
- Requests terminated with target retry can be accepted and completed in any order with respect to other transactions that have been terminated with target retry. If the order of completion of delayed requests is important, the initiator should not start a second delayed transaction until the first one has been completed. If more than one delayed transaction is initiated, the initiator should repeat all the delayed transaction requests, using some fairness algorithm. Repeating a delayed transaction cannot be contingent on completion of another delayed transaction; otherwise, a deadlock can occur.
- Write transactions flowing in one direction have no ordering requirements with respect to write transactions flowing in the other direction. The 21150 can accept posted write transactions on both interfaces at the same time, as well as initiate posted write transactions on both interfaces at the same time.
- The acceptance of a posted memory write transaction as a target can never be contingent on the completion of a nonlocked, nonposted transaction as a master. This is true of the 21150 and must also be true of other bus agents; otherwise, a deadlock can occur.
- The 21150 accepts posted write transactions, regardless of the state of completion of any delayed transactions being forwarded across the 21150.

6.3 Ordering Rules

Table 24 shows the ordering relationships of all the transactions and refers by number to the ordering rules that follow.

Note: The superscript accompanying some of the table entries refers to any applicable ordering rule listed in this section. Many entries are not governed by these ordering rules; therefore, the implementation can choose whether or not the transactions pass each other.

The entries without superscripts reflect the 21150's implementation choices.

Table 24. Summary of Transaction Ordering (Sheet 1 of 2)

↓ Pass →	Posted Write	Delayed Read Request	Delayed Write Request	Delayed Read Completion	Delayed Write Completion
Posted write	No ¹	Yes ⁵	Yes ⁵	Yes ⁵	Yes ⁵
Delayed read request	No ²	No	No	Yes	Yes

Table 24. Summary of Transaction Ordering (Sheet 2 of 2)

↓ Pass →	Posted Write	Delayed Read Request	Delayed Write Request	Delayed Read Completion	Delayed Write Completion
Delayed write request	No ⁴	No	No	Yes	Yes
Delayed read completion	No ³	Yes	Yes	No	No
Delayed write completion	Yes	Yes	Yes	No	No

The following ordering rules describe the transaction relationships. Each ordering rule is followed by an explanation, and the ordering rules are referred to by number in Table 24. These ordering rules apply to posted write transactions, delayed write and read requests, and delayed write and read completion transactions crossing the 21150 in the same direction. Note that delayed completion transactions cross the 21150 in the direction opposite that of the corresponding delayed requests.

1. Posted write transactions must complete on the target bus in the order in which they were received on the initiator bus.

The subsequent posted write transaction can be setting a flag that covers the data in the first posted write transaction; if the second transaction were to complete before the first transaction, a device checking the flag could subsequently consume stale data.
2. A delayed read request traveling in the same direction as a previously queued posted write transaction must push the posted write data ahead of it. The posted write transaction must complete on the target bus before the delayed read request can be attempted on the target bus.

The read transaction can be to the same location as the write data, so if the read transaction were to pass the write transaction, it would return stale data.
3. A delayed read completion must “pull” ahead of previously queued posted write data traveling in the same direction. In this case, the read data is traveling in the same direction as the write data, and the initiator of the read transaction is on the same side of the 21150 as the target of the write transaction. The posted write transaction must complete to the target before the read data is returned to the initiator.

The read transaction can be to a status register of the initiator of the posted write data and therefore should not complete until the write transaction is complete.
4. Delayed write requests cannot pass previously queued posted write data.

As in the case of posted memory write transactions, the delayed write transaction can be setting a flag that covers the data in the posted write transaction; if the delayed write request were to complete before the earlier posted write transaction, a device checking the flag could subsequently consume stale data.
5. Posted write transactions must be given opportunities to pass delayed read and write requests and completions.

Otherwise, deadlocks may occur when bridges that support delayed transactions are used in the same system with bridges that do not support delayed transactions. A fairness algorithm is used to arbitrate between the posted write queue and the delayed transaction queue.

6.4 Data Synchronization

Data synchronization refers to the relationship between interrupt signaling and data delivery. The *PCI Local Bus Specification, Revision 2.1*, provides the following alternative methods for synchronizing data and interrupts:

- The device signaling the interrupt performs a read of the data just written (software).
- The device driver performs a read operation to any register in the interrupting device before accessing data written by the device (software).
- System hardware guarantees that write buffers are flushed before interrupts are forwarded.

The 21150 does not have a hardware mechanism to guarantee data synchronization for posted write transactions. Therefore, all posted write transactions must be followed by a read operation, either from the device to the location just written (or some other location along the same path), or from the device driver to one of the device registers.

7.0 Error Handling

The 21150 checks, forwards, and generates parity on both the primary and secondary interfaces. To maintain transparency, the 21150 always tries to forward the existing parity condition on one bus to the other bus, along with address and data. The 21150 always attempts to be transparent when reporting errors, but this is not always possible, given the presence of posted data and delayed transactions.

To support error reporting on the PCI bus, the 21150 implements the following:

- PERR# and SERR# signals on both the primary and secondary interfaces
- Primary status and secondary status registers
- The device-specific p_serr_l event disable register
- The device-specific p_serr_l status register

This chapter provides detailed information about how the 21150 handles errors. It also describes error status reporting and error operation disabling.

7.1 Address Parity Errors

The 21150 checks address parity for all transactions on both buses, for all address and all bus commands.

When the 21150 detects an address parity error on the primary interface, the following events occur:

- If the parity error response bit is set in the command register, the 21150 does not claim the transaction with p_devsel_l; this may allow the transaction to terminate in a master abort. If the parity error response bit is not set, the 21150 proceeds normally and accepts the transaction if it is directed to or across the 21150.
- The 21150 sets the detected parity error bit in the status register.
- The 21150 asserts p_serr_l and sets the signaled system error bit in the status register, if both of the following conditions are met:
 - The SERR# enable bit is set in the command register.
 - The parity error response bit is set in the command register.

When the 21150 detects an address parity error on the secondary interface, the following events occur:

- If the parity error response bit is set in the bridge control register, the 21150 does not claim the transaction with s_devsel_l; this may allow the transaction to terminate in a master abort. If the parity error response bit is not set, the 21150 proceeds normally and accepts the transaction if it is directed to or across the 21150.
- The 21150 sets the detected parity error bit in the secondary status register.

- The 21150 asserts `p_serr_l` and sets the signaled system error bit in the status register, if both of the following conditions are met:
 - The `SERR#` enable bit is set in the command register.
 - The parity error response bit is set in the bridge control register.

7.2 Data Parity Errors

When forwarding transactions, the 21150 attempts to pass the data parity condition from one interface to the other unchanged, whenever possible, to allow the master and target devices to handle the error condition.

The following sections describe, for each type of transaction, the sequence of events that occurs when a parity error is detected and the way in which the parity condition is forwarded across the 21150.

7.2.1 Configuration Write Transactions to 21150 Configuration Space

When the 21150 detects a data parity error during a Type 0 configuration write transaction to 21150 configuration space, the following events occur:

- If the parity error response bit is set in the command register, the 21150 asserts `p_trdy_l` and writes the data to the configuration register. The 21150 also asserts `p_perr_l`.
If the parity error response bit is not set, the 21150 does not assert `p_perr_l`.
- The 21150 sets the detected parity error bit in the status register, regardless of the state of the parity error response bit.

7.2.2 Read Transactions

When the 21150 detects a parity error during a read transaction, the target drives data and data parity, and the initiator checks parity and conditionally asserts `PERR#`.

For downstream transactions, when the 21150 detects a read data parity error on the secondary bus, the following events occur:

- The 21150 asserts `s_perr_l` two cycles following the data transfer, if the secondary interface parity error response bit is set in the bridge control register.
- The 21150 sets the detected parity error bit in the secondary status register.
- The 21150 sets the data parity detected bit in the secondary status register, if the secondary interface parity error response bit is set in the bridge control register.
- The 21150 forwards the bad parity with the data back to the initiator on the primary bus.
If the data with the bad parity is prefetched and is not read by the initiator on the primary bus, the data is discarded and the data with bad parity is not returned to the initiator.
- The 21150 completes the transaction normally.

For upstream transactions, when the 21150 detects a read data parity error on the primary bus, the following events occur:

- The 21150 asserts p_perr_l two cycles following the data transfer, if the primary interface parity error response bit is set in the command register
- The 21150 sets the detected parity error bit in the primary status register.
- The 21150 sets the data parity detected bit in the primary status register, if the primary interface parity error response bit is set in the command register.
- The 21150 forwards the bad parity with the data back to the initiator on the secondary bus. If the data with the bad parity is prefetched and is not read by the initiator on the secondary bus, the data is discarded and the data with bad parity is not returned to the initiator.
- The 21150 completes the transaction normally.
The 21150 returns to the initiator the data and parity that was received from the target. When the initiator detects a parity error on this read data and is enabled to report it, the initiator asserts PERR# two cycles after the data transfer occurs. It is assumed that the initiator takes responsibility for handling a parity error condition; therefore, when the 21150 detects PERR# asserted while returning read data to the initiator, the 21150 does not take any further action and completes the transaction normally.

7.2.3 Delayed Write Transactions

When the 21150 detects a data parity error during a delayed write transaction, the initiator drives data and data parity, and the target checks parity and conditionally asserts PERR#.

For delayed write transactions, a parity error can occur at the following times:

- During the original delayed write request transaction
- When the initiator repeats the delayed write request transaction
- When the 21150 completes the delayed write transaction to the target

When a delayed write transaction is normally queued, the address, command, address parity, data, byte enable bits, and data parity are all captured and a target retry is returned to the initiator. When the 21150 detects a parity error on the write data for the initial delayed write request transaction, the following events occur:

- If the parity error response bit corresponding to the initiator bus is set, the 21150 asserts TRDY# to the initiator and the transaction is not queued. If multiple data phases are requested, STOP# is also asserted to cause a target disconnect. Two cycles after the data transfer, the 21150 also asserts PERR#. If the parity error response bit is not set, the 21150 returns a target retry and queues the transaction as usual. Signal PERR# is not asserted. In this case, the initiator repeats the transaction.
- The 21150 sets the detected parity error bit in the status register corresponding to the initiator bus, regardless of the state of the parity error response bit.

Note: If parity checking is turned off and data parity errors have occurred for queued or subsequent delayed write transactions on the initiator bus, it is possible that the initiator's reattempts of the write transaction may not match the original queued delayed write information contained in the delayed transaction queue. In this case, a master timeout condition may occur, possibly resulting in a system error (p_serr_l asserted).

For downstream transactions, when the 21150 is delivering data to the target on the secondary bus and s_perr_l is asserted by the target, the following events occur:

- The 21150 sets the secondary interface data parity detected bit in the secondary status register, if the secondary parity error response bit is set in the bridge control register.
- The 21150 captures the parity error condition to forward it back to the initiator on the primary bus.

Similarly, for upstream transactions, when the 21150 is delivering data to the target on the primary bus and p_perr_1 is asserted by the target, the following events occur:

- The 21150 sets the primary interface data parity detected bit in the status register, if the primary parity error response bit is set in the command register.
- The 21150 captures the parity error condition to forward it back to the initiator on the secondary bus.

A delayed write transaction is completed on the initiator bus when the initiator repeats the write transaction with the same address, command, data, and byte enable bits as the delayed write command that is at the head of the posted data queue. Note that the parity bit is not compared when determining whether the transaction matches those in the delayed transaction queues.

Two cases must be considered:

- When parity error is detected on the initiator bus on a subsequent reattempt of the transaction and was not detected on the target bus.
- When parity error is forwarded back from the target bus.

For downstream delayed write transactions, when the parity error is detected on the initiator bus and the 21150 has write status to return, the following events occur:

- The 21150 first asserts p_trdy_1 and then asserts p_perr_1 two cycles later, if the primary interface parity error response bit is set in the command register.
- The 21150 sets the primary interface parity error detected bit in the status register.
- Because there was not an exact data and parity match, the write status is not returned and the transaction remains in the queue.

Similarly, for upstream delayed write transactions, when the parity error is detected on the initiator bus and the 21150 has write status to return, the following events occur:

- The 21150 first asserts s_trdy_1 and then asserts s_perr_1 two cycles later, if the secondary interface parity error response bit is set in the bridge control register.
- The 21150 sets the secondary interface parity error detected bit in the secondary status register.
- Because there was not an exact data and parity match, the write status is not returned and the transaction remains in the queue.

For downstream transactions, in the case where the parity error is being passed back from the target bus and the parity error condition was not originally detected on the initiator bus, the following events occur:

- The 21150 asserts p_perr_1 two cycles after the data transfer, if both of the following are true:
 - The primary interface parity error response bit is set in the command register.
 - The secondary interface parity error response bit is set in the bridge control register.
- The 21150 completes the transaction normally.

For upstream transactions, in the case where the parity error is being passed back from the target bus and the initiator bus, the following events occur:

- The 21150 asserts `s_perr_1` two cycles after the data transfer, if both of the following are true:
 - The primary interface parity error response bit is set in the command register.
 - The secondary interface parity error response bit is set in the bridge control register.
- The 21150 completes the transaction normally.

7.2.4 Posted Write Transactions

During downstream posted write transactions, when the 21150, responding as a target, detects a data parity error on the initiator (primary) bus, the following events occur:

- The 21150 asserts `p_perr_1` two cycles after the data transfer, if the primary interface parity error response bit is set in the command register.
- The 21150 sets the primary interface parity error detected bit in the status register.
- The 21150 captures and forwards the bad parity condition to the secondary bus.
- The 21150 completes the transaction normally.

Similarly, during upstream posted write transactions, when the 21150, responding as a target, detects a data parity error on the initiator (secondary) bus, the following events occur:

- The 21150 asserts `s_perr_1` two cycles after the data transfer, if the secondary interface parity error response bit is set in the bridge control register.
- The 21150 sets the secondary interface parity error detected bit in the secondary status register.
- The 21150 captures and forwards the bad parity condition to the primary bus.
- The 21150 completes the transaction normally.

During downstream write transactions, when a data parity error is reported on the target (secondary) bus by the target's assertion of `s_perr_1`, the following events occur:

- The 21150 sets the data parity detected bit in the secondary status register, if the secondary interface parity error response bit is set in the bridge control register.
- The 21150 asserts `p_serr_1` and sets the signaled system error bit in the status register, if all of the following conditions are met:
 - The `SERR#` enable bit is set in the command register.
 - The device-specific `p_serr_1` disable bit for posted write parity errors is not set.
 - The secondary interface parity error response bit is set in the bridge control register.
 - The primary interface parity error response bit is set in the command register.
 - The 21150 did not detect the parity error on the primary (initiator) bus; that is, the parity error was not forwarded from the primary bus.

During upstream write transactions, when a data parity error is reported on the target (primary) bus by the target's assertion of `p_perr_1`, the following events occur:

- The 21150 sets the data parity detected bit in the status register, if the primary interface parity error response bit is set in the command register.

- The 21150 asserts `p_serr_l` and sets the signaled system error bit in the status register, if all of the following conditions are met:
 - The `SERR#` enable bit is set in the command register.
 - The secondary interface parity error response bit is set in the bridge control register.
 - The primary interface parity error response bit is set in the command register.
 - The 21150 did not detect the parity error on the secondary (initiator) bus; that is, the parity error was not forwarded from the secondary bus.

The assertion of `p_serr_l` is used to signal the parity error condition in the case where the initiator does not know that the error occurred. Because the data has already been delivered with no errors, there is no other way to signal this information back to the initiator.

If the parity error was forwarded from the initiating bus to the target bus, `p_serr_l` is not asserted.

7.3 Data Parity Error Reporting Summary

In the previous sections, the 21150's responses to data parity errors are presented according to the type of transaction in progress. This section organizes the 21150's responses to data parity errors according to the status bits that the 21150 sets and the signals that it asserts.

Table 25 shows setting the detected parity error bit in the status register, corresponding to the primary interface. This bit is set when the 21150 detects a parity error on the primary interface.

Table 25. Setting the Primary Interface Detected Parity Error Bit

Primary Detected Parity Error Bit	Transaction Type	Direction	Bus Where Error Was Detected	Primary/Secondary Parity Error Response Bits
0	Read	Downstream	Primary	x/x ¹
0	Read	Downstream	Secondary	x/x
1	Read	Upstream	Primary	x/x
0	Read	Upstream	Secondary	x/x
1	Posted write	Downstream	Primary	x/x
0	Posted write	Downstream	Secondary	x/x
0	Posted write	Upstream	Primary	x/x
0	Posted write	Upstream	Secondary	x/x
1	Delayed write	Downstream	Primary	x/x
0	Delayed write	Downstream	Secondary	x/x
0	Delayed write	Upstream	Primary	x/x
0	Delayed write	Upstream	Secondary	x/x

¹: x = don't care

Table 26 shows setting the detected parity error bit in the secondary status register, corresponding to the secondary interface. This bit is set when the 21150 detects a parity error on the secondary interface.

Table 26. Setting the Secondary Interface Detected Parity Error Bit

Secondary Detected Parity Error Bit	Transaction Type	Direction	Bus Where Error Was Detected	Primary/Secondary Parity Error Response Bits
0	Read	Downstream	Primary	x/x ¹
1	Read	Downstream	Secondary	x/x
0	Read	Upstream	Primary	x/x
0	Read	Upstream	Secondary	x/x
0	Posted write	Downstream	Primary	x/x
0	Posted write	Downstream	Secondary	x/x
0	Posted write	Upstream	Primary	x/x
1	Posted write	Upstream	Secondary	x/x
0	Delayed write	Downstream	Primary	x/x
0	Delayed write	Downstream	Secondary	x/x
0	Delayed write	Upstream	Primary	x/x
1	Delayed write	Upstream	Secondary	x/x

¹: x = don't care

Table 27 shows setting the data parity detected bit in the status register, corresponding to the primary interface. This bit is set under the following conditions:

- The 21150 must be a master on the primary bus.
- The parity error response bit in the command register, corresponding to the primary interface, must be set.
- The p_perr_1 signal is detected asserted or a parity error is detected on the primary bus.

Table 27. Setting the Primary Interface Data Parity Detected Bit

Primary Data Parity Detected Bit	Transaction Type	Direction	Bus Where Error Was Detected	Primary/Secondary Parity Error Response Bits
0	Read	Downstream	Primary	x/x ¹
0	Read	Downstream	Secondary	x/x
1	Read	Upstream	Primary	1/x
0	Read	Upstream	Secondary	x/x
0	Posted write	Downstream	Primary	x/x
0	Posted write	Downstream	Secondary	x/x
1	Posted write	Upstream	Primary	1/x
0	Posted write	Upstream	Secondary	x/x
0	Delayed write	Downstream	Primary	x/x
0	Delayed write	Downstream	Secondary	x/x
1	Delayed write	Upstream	Primary	1/x
0	Delayed write	Upstream	Secondary	x/x

¹: x = don't care

Table 28 shows setting the data parity detected bit in the secondary status register, corresponding to the secondary interface. This bit is set under the following conditions:

- The 21150 must be a master on the secondary bus.
- The parity error response bit in the bridge control register, corresponding to the secondary interface, must be set.
- The s_perr_l signal is detected asserted or a parity error is detected on the secondary bus.

Table 28. Setting the Secondary Interface Data Parity Detected Bit

Secondary Data Parity Detected Bit	Transaction Type	Direction	Bus Where Error Was Detected	Primary/Secondary Parity Error Response Bits
0	Read	Downstream	Primary	x/x ¹
1	Read	Downstream	Secondary	x/1
0	Read	Upstream	Primary	x/x
0	Read	Upstream	Secondary	x/x
0	Posted write	Downstream	Primary	x/x
1	Posted write	Downstream	Secondary	x/1
0	Posted write	Upstream	Primary	x/x
0	Posted write	Upstream	Secondary	x/x
0	Delayed write	Downstream	Primary	x/x
1	Delayed write	Downstream	Secondary	x/1
0	Delayed write	Upstream	Primary	x/x
0	Delayed write	Upstream	Secondary	x/x

¹: x = don't care

Table 29 shows assertion of p_perr_l. This signal is set under the following conditions:

- The 21150 is either the target of a write transaction or the initiator of a read transaction on the primary bus.
- The parity error response bit in the command register, corresponding to the primary interface, must be set.
- The 21150 detects a data parity error on the primary bus or detects s_perr_l asserted during the completion phase of a downstream delayed write transaction on the target (secondary) bus.

Table 29. Assertion of p_perr_l (Sheet 1 of 2)

p_perr_l	Transaction Type	Direction	Bus Where Error Was Detected	Primary/Secondary Parity Error Response Bits
1 (deasserted)	Read	Downstream	Primary	x/x ¹
1	Read	Downstream	Secondary	x/x
0 (asserted)	Read	Upstream	Primary	1/x
1	Read	Upstream	Secondary	x/x
0	Posted write	Downstream	Primary	1/x
1	Posted write	Downstream	Secondary	x/1

Table 29. Assertion of p_perr_l (Sheet 2 of 2)

p_perr_l	Transaction Type	Direction	Bus Where Error Was Detected	Primary/Secondary Parity Error Response Bits
1	Posted write	Upstream	Primary	x/x
1	Posted write	Upstream	Secondary	x/x
0	Delayed write	Downstream	Primary	1/x
0 ¹	Delayed write	Downstream	Secondary	1/1
1	Delayed write	Upstream	Primary	x/x
1	Delayed write	Upstream	Secondary	x/x

¹. x = don't care

Table 30 shows assertion of s_perr_l. This signal is set under the following conditions:

- The 21150 is either the target of a write transaction or the initiator of a read transaction on the secondary bus.
- The parity error response bit in the bridge control register, corresponding to the secondary interface, must be set.
- The 21150 detects a data parity error on the secondary bus or detects p_perr_l asserted during the completion phase of an upstream delayed write transaction on the target (primary) bus.

Table 30. Assertion of s_perr_l

s_perr_l	Transaction Type	Direction	Bus Where Error Was Detected	Primary/Secondary Parity Error Response Bits
1 (deasserted)	Read	Downstream	Primary	x/x ¹
0 (asserted)	Read	Downstream	Secondary	x/1
1	Read	Upstream	Primary	x/x
1	Read	Upstream	Secondary	x/x
1	Posted write	Downstream	Primary	x/x
1	Posted write	Downstream	Secondary	x/x
1	Posted write	Upstream	Primary	x/x
0	Posted write	Upstream	Secondary	x/1
1	Delayed write	Downstream	Primary	1/x
1	Delayed write	Downstream	Secondary	x/x
0 ¹	Delayed write	Upstream	Primary	1/1
0	Delayed write	Upstream	Secondary	x/1

¹. x = don't care

Table 31 shows assertion of p_serr_l. This signal is set under the following conditions:

- The 21150 has detected p_perr_l asserted on an upstream posted write transaction or s_perr_l asserted on a downstream posted write transaction.
- The 21150 did not detect the parity error as a target of the posted write transaction.

- The parity error response bit on the command register and the parity error response bit on the bridge control register must both be set.
- The SERR# enable bit must be set in the command register.

Table 31. Assertion of p_serr_l for Data Parity Errors

p_serr_l	Transaction Type	Direction	Bus Where Error Was Detected	Primary/Secondary Parity Error Response Bits
1 (deasserted)	Read	Downstream	Primary	x/x ¹
1	Read	Downstream	Secondary	x/x
1	Read	Upstream	Primary	x/x
1	Read	Upstream	Secondary	x/x
1	Posted write	Downstream	Primary	x/x
0 ²	Posted write	Downstream	Secondary	1/1
0 ³	Posted write	Upstream	Primary	1/1
1	Posted write	Upstream	Secondary	x/x
1	Delayed write	Downstream	Primary	x/x
1	Delayed write	Downstream	Secondary	x/x
1	Delayed write	Upstream	Primary	x/x
1	Delayed write	Upstream	Secondary	x/x

¹. x = don't care

². The parity error was detected on the target (secondary) bus but not on the initiator (primary) bus.

³. The parity error was detected on the target (primary) bus but not on the initiator (secondary) bus.

7.4 System Error (SERR#) Reporting

The 21150 uses the p_serr_l signal to report conditionally a number of system error conditions in addition to the special case parity error conditions described in [Section 7.2.3](#).

Whenever the assertion of p_serr_l is discussed in this document, it is assumed that the following conditions apply:

- For the 21150 to assert p_serr_l for any reason, the SERR# enable bit must be set in the command register.
- Whenever the 21150 asserts p_serr_l, the 21150 must also set the signaled system error bit in the status register.

In compliance with the *PCI-to-PCI Bridge Architecture Specification*, the 21150 asserts p_serr_l when it detects the secondary SERR# input, s_serr_l, asserted and the SERR# forward enable bit is set in the bridge control register. In addition, the 21150 also sets the received system error bit in the secondary status register.

The 21150 also conditionally asserts p_serr_l for any of the following reasons:

- Target abort detected during posted write transaction
- Master abort detected during posted write transaction
- Posted write data discarded after 2²⁴ attempts to deliver (2²⁴ target retries received)

- Parity error reported on target bus during posted write transaction (see previous section)
- Delayed write data discarded after 2^{24} attempts to deliver (2^{24} target retries received)
- Delayed read data cannot be transferred from target after 2^{24} attempts (2^{24} target retries received)
- Master timeout on delayed transaction

The device-specific p_serr_1 status register reports the reason for the 21150's assertion of p_serr_1.

Most of these events have additional device-specific disable bits in the p_serr_1 event disable register that make it possible to mask out p_serr_1 assertion for specific events. The master timeout condition has a SERR# enable bit for that event in the bridge control register and therefore does not have a device-specific disable bit.

8.0 Exclusive Access

This chapter describes the use of the LOCK# signal to implement exclusive access to a target for transactions that cross the 21150.

8.1 Concurrent Locks

The primary and secondary bus lock mechanisms operate concurrently except when a locked transaction crosses the 21150. A primary master can lock a primary target without affecting the status of the lock on the secondary bus, and vice versa. This means that a primary master can lock a primary target at the same time that a secondary master locks a secondary target.

8.2 Acquiring Exclusive Access Across the 21150

For any PCI bus, before acquiring access to the LOCK# signal and starting a series of locked transactions, the initiator must first check that both of the following conditions are met:

- The PCI bus must be idle.
- The LOCK# signal must be deasserted.

The initiator leaves the LOCK# signal deasserted during the address phase (only the first address phase of a dual address transaction) and asserts LOCK# one clock cycle later. Once a data transfer is completed from the target, the target lock has been achieved.

Locked transactions can cross the 21150 only in the downstream direction, from the primary bus to the secondary bus.

When the target resides on another PCI bus, the master must acquire not only the lock on its own PCI bus but also the lock on every bus between its bus and the target's bus. When the 21150 detects, on the primary bus, an initial locked transaction intended for a target on the secondary bus, the 21150 samples the address, transaction type, byte enable bits, and parity, as described in [Section 4.6.4](#). It also samples the lock signal.

Because a target retry is signaled to the initiator, the initiator must relinquish the lock on the primary bus, and therefore the lock is not yet established.

The first locked transaction must be a read transaction. Subsequent locked transactions can be read or write transactions. Posted memory write transactions that are a part of the locked transaction sequence are still posted. Memory read transactions that are a part of the locked transaction sequence are not prefetched.

When the locked delayed read request is queued, the 21150 does not queue any more transactions until the locked sequence is finished. The 21150 signals a target retry to all transactions initiated subsequent to the locked read transaction that are intended for targets on the other side of the 21150. The 21150 allows any transactions queued before the locked transaction to complete before initiating the locked transaction.

When the locked delayed read request transaction moves to the head of the delayed transaction queue, the 21150 initiates the transaction as a locked read transaction by deasserting `s_lock_1` on the secondary bus during the first address phase, and by asserting `s_lock_1` one cycle later. If

s_lock_1 is already asserted (used by another initiator), the 21150 waits to request access to the secondary bus until s_lock_1 is sampled deasserted when the secondary bus is idle. Note that the existing lock on the secondary bus could not have crossed the 21150; otherwise, the pending queued locked transaction would not have been queued. When the 21150 is able to complete a data transfer with the locked read transaction, the lock is established on the secondary bus.

When the initiator repeats the locked read transaction on the primary bus with the same address, transaction type, and byte enable bits, the 21150 transfers the read data back to the initiator, and the lock is then also established on the primary bus.

For the 21150 to recognize and respond to the initiator, the initiator's subsequent attempts of the read transaction must use the locked transaction sequence (deassert p_lock_1 during address phase, and assert p_lock_1 one cycle later). If the LOCK# sequence is not used in subsequent attempts, a master timeout condition may result. When a master timeout condition occurs, p_serr_1 is conditionally asserted (see [Section 7.4](#)), the read data and queued read transaction are discarded, and the s_lock_1 signal is deasserted on the secondary bus.

Once the intended target has been locked, any subsequent locked transactions initiated on the primary bus that are forwarded by the 21150 are driven as locked transactions on the secondary bus.

When the 21150 receives a target abort or a master abort in response to the delayed locked read transaction, a target abort is returned to the initiator, and no locks are established on either the target or the initiator bus. The 21150 resumes forwarding unlocked transactions in both directions.

When the 21150 detects, on the secondary bus, a locked delayed transaction request intended for a target on the primary bus, the 21150 queues and forwards the transaction as an unlocked transaction. The 21150 ignores s_lock_1 for upstream transactions and initiates all upstream transactions as unlocked transactions.

8.3 Ending Exclusive Access

After the lock has been acquired on both the primary and secondary buses, the 21150 must maintain the lock on the secondary (target) bus for any subsequent locked transactions until the initiator relinquishes the lock.

The only time a target retry causes the lock to be relinquished is on the first transaction of a locked sequence. On subsequent transactions in the sequence, the target retry has no effect on the status of the lock signal.

An established target lock is maintained until the initiator relinquishes the lock. The 21150 does not know whether the current transaction is the last one in a sequence of locked transactions until the initiator deasserts the p_lock_1 signal at the end of the transaction.

When the last locked transaction is a delayed transaction, the 21150 has already completed the transaction on the secondary bus. In this case, as soon as the 21150 detects that the initiator has relinquished the p_lock_1 signal by sampling it in the deasserted state while p_frame_1 is deasserted, the 21150 deasserts the s_lock_1 signal on the secondary bus as soon as possible. Because of this behavior, s_lock_1 may not be deasserted until several cycles after the last locked transaction has been completed on the secondary bus. As soon as the 21150 has deasserted s_lock_1 to indicate the end of a sequence of locked transactions, it resumes forwarding unlocked transactions.

When the last locked transaction is a posted write transaction, the 21150 deasserts `s_lock_l` on the secondary bus at the end of the transaction because the lock was relinquished at the end of the write transaction on the primary bus.

When the 21150 receives a target abort or a master abort in response to a locked delayed transaction, the 21150 returns a target abort when the initiator repeats the locked transaction. The initiator must then deassert `p_lock_l` at the end of the transaction. The 21150 sets the appropriate status bits, flagging the abnormal target termination condition (see [Section 4.8](#)). Normal forwarding of unlocked posted and delayed transactions is resumed.

When the 21150 receives a target abort or a master abort in response to a locked posted write transaction, the 21150 cannot pass back that status to the initiator. The 21150 asserts `p_serr_l` when a target abort or a master abort is received during a locked posted write transaction, if the `SERR#` enable bit is set in the command register. Signal `p_serr_l` is asserted for the master abort condition if the master abort mode bit is set in the bridge control register (see [Section 7.4](#)).

9.0 PCI Bus Arbitration

The 21150 must arbitrate for use of the primary bus when forwarding upstream transactions, and for use of the secondary bus when forwarding downstream transactions. The arbiter for the primary bus resides external to the 21150, typically on the motherboard. For the secondary PCI bus, the 21150 implements an internal arbiter. This arbiter can be disabled, and an external arbiter can be used instead.

This chapter describes primary and secondary bus arbitration.

9.1 Primary PCI Bus Arbitration

The 21150 implements a request output pin, `p_req_l`, and a grant input pin, `p_gnt_l`, for primary PCI bus arbitration. The 21150 asserts `p_req_l` when forwarding transactions upstream; that is, it acts as initiator on the primary PCI bus. As long as at least one pending transaction resides in the queues in the upstream direction, either posted write data or delayed transaction requests, the 21150 keeps `p_req_l` asserted. However, if a target retry, target disconnect, or a target abort is received in response to a transaction initiated by the 21150 on the primary PCI bus, the 21150 deasserts `p_req_l` for two PCI clock cycles.

For posted write transactions (see [Section 4.5.1](#)), `p_req_l` is asserted one cycle after `s_devsel_l` is asserted. For delayed read and write requests, `p_req_l` is not asserted until the transaction request has been completely queued in the delayed transaction queue (target retry has been returned to the initiator) and is at the head of the delayed transaction queue.

When `p_gnt_l` is asserted low by the primary bus arbiter after the 21150 has asserted `p_req_l`, the 21150 initiates a transaction on the primary bus during the next PCI clock cycle. When `p_gnt_l` is asserted to the 21150 when `p_req_l` is not asserted, the 21150 parks `p_ad`, `p_cbe_l`, and `p_par` by driving them to valid logic levels. When the primary bus is parked at the 21150 and the 21150 then has a transaction to initiate on the primary bus, the 21150 starts the transaction if `p_gnt_l` was asserted during the previous cycle.

9.2 Secondary PCI Bus Arbitration

The 21150 implements an internal secondary PCI bus arbiter. This arbiter supports nine external masters in addition to the 21150.

The internal arbiter can be disabled, and an external arbiter can be used instead for secondary bus arbitration.

9.2.1 Secondary Bus Arbitration Using the Internal Arbiter

To use the internal arbiter, the secondary bus arbiter enable pin, `s_cfn_l`, must be tied low. The 21150 has nine secondary bus request input pins, `s_req_l<8:0>`, and nine secondary bus output grant pins, `s_gnt_l<8:0>`, to support external secondary bus masters. The 21150 secondary bus request and grant signals are connected internally to the arbiter and are not brought out to external pins when `s_cfn_l` is low.

The secondary arbiter supports a programmable 2-level rotating algorithm. Two groups of masters are assigned, a high priority group and a low priority group. The low priority group as a whole represents one entry in the high priority group; that is, if the high priority group consists of n masters, then in at least every $n+1$ transactions the highest priority is assigned to the low priority group. Priority rotates evenly among the low priority group. Therefore, members of the high priority group can be serviced n transactions out of $n+1$, while one member of the low priority group is serviced once every $n+1$ transactions. Figure 18 shows an example of an internal arbiter where four masters, including the 21150, are in the high priority group, and six masters are in the low priority group. Using this example, if all requests are always asserted, the highest priority rotates among the masters in the following fashion (high priority members are given in *italics*, low priority members, in **boldface** type):

B, m0, m1, m2, m3, B, m0, m1, m2, m4, B, m0, m1, m2, m5, B, m0, m1, m2, m6, B, m0, m1, and so on.

Figure 18. Secondary Arbiter Example

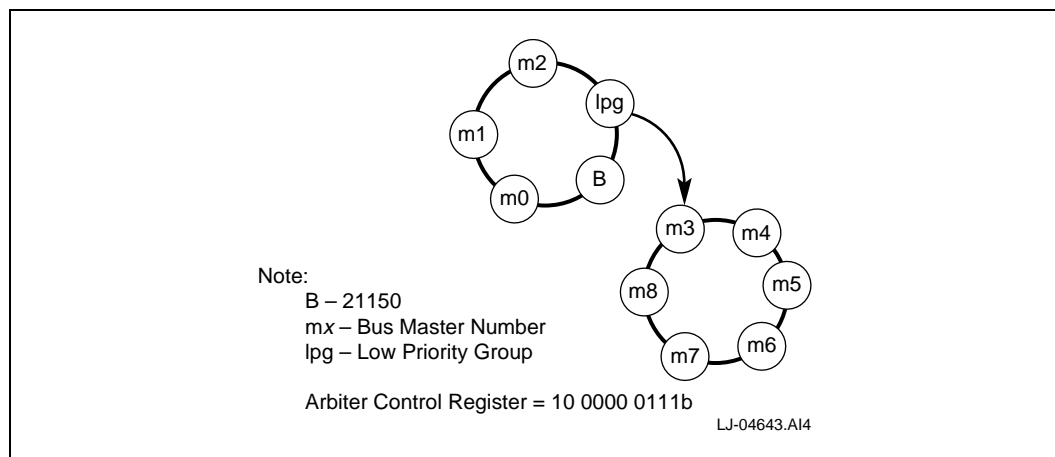

Each bus master, including the 21150, can be configured to be in either the low priority group or the high priority group by setting the corresponding priority bit in the arbiter control register in device-specific configuration space. Each master has a corresponding bit. If the bit is set to 1, the master is assigned to the high priority group. If the bit is set to 0, the master is assigned to the low priority group. If all the masters are assigned to one group, the algorithm defaults to a straight rotating priority among all the masters. After reset, all external masters are assigned to the low priority group, and the 21150 is assigned to the high priority group. The 21150 receives highest priority on the target bus every other transaction, and priority rotates evenly among the other masters.

Priorities are reevaluated every time `s_frame_1` is asserted, that is, at the start of each new transaction on the secondary PCI bus. From this point until the time that the next transaction starts, the arbiter asserts the grant signal corresponding to the highest priority request that is asserted. If a grant for a particular request is asserted, and a higher priority request subsequently asserts, the arbiter deasserts the asserted grant signal and asserts the grant corresponding to the new higher priority request on the next PCI clock cycle. When priorities are reevaluated, the highest priority is assigned to the next highest priority master relative to the master that initiated the previous transaction. The master that initiated the last transaction now has the lowest priority in its group.

If the 21150 detects that an initiator has failed to assert `s_frame_1` after 16 cycles of both grant assertion and a secondary idle bus condition, the arbiter deasserts the grant. That master does not receive any more grants until it deasserts its request for at least one PCI clock cycle.

To prevent bus contention, if the secondary PCI bus is idle, the arbiter never asserts one grant signal in the same PCI cycle in which it deasserts another. It deasserts one grant, and then asserts the next grant, no earlier than one PCI clock cycle later. If the secondary PCI bus is busy, that is, either `s_frame_1` or `s_irdy_1` is asserted, the arbiter can deassert one grant and assert another grant during the same PCI clock cycle.

9.2.2 Secondary Bus Arbitration Using an External Arbiter

The internal arbiter is disabled when the secondary bus central function control pin, `s_cfn_1`, is pulled high. An external arbiter must then be used.

When `s_cfn_1` is tied high, the 21150 reconfigures two pins to be external request and grant pins. The `s_gnt_1<0>` pin is reconfigured to be the 21150's external request pin because it is an output. The `s_req_1<0>` pin is reconfigured to be the external grant pin because it is an input. When an external arbiter is used, the 21150 uses the `s_gnt_1<0>` pin to request the secondary bus. When the reconfigured `s_req_1<0>` pin is asserted low after the 21150 has asserted `s_gnt_1<0>`, the 21150 initiates a transaction on the secondary bus one cycle later. If `s_req_1<0>` is asserted and the 21150 has not asserted `s_gnt_1<0>`, the 21150 parks the `s_ad`, `s_cbe_1`, and `s_par` pins by driving them to valid logic levels.

The unused secondary bus grant outputs, `s_gnt_1<8:1>`, are driven high. Unused secondary bus request inputs, `s_req_1<8:1>`, should be pulled high.

9.2.3 Bus Parking

Bus parking refers to driving the AD, C/BE#, and PAR lines to a known value while the bus is idle. In general, the device implementing the bus arbiter is responsible for parking the bus or assigning another device to park the bus. A device parks the bus when the bus is idle, its bus grant is asserted, and the device's request is not asserted. The AD and C/BE# signals should be driven first, with the PAR signal driven one cycle later.

The 21150 parks the primary bus only when `p_gnt_1` is asserted, `p_req_1` is deasserted, and the primary PCI bus is idle. When `p_gnt_1` is deasserted, the 21150 tristates the `p_ad`, `p_cbe_1`, and `p_par` signals on the next PCI clock cycle. If the 21150 is parking the primary PCI bus and wants to initiate a transaction on that bus, then the 21150 can start the transaction on the next PCI clock cycle by asserting `p_frame_1` if `p_gnt_1` is still asserted.

If the internal secondary bus arbiter is enabled, the secondary bus is always parked at the last master that used the PCI bus. That is, the 21150 keeps the secondary bus grant asserted to a particular master until a new secondary bus request comes along. After reset, the 21150 parks the secondary bus at itself until transactions start occurring on the secondary bus. If the internal arbiter is disabled, the 21150 parks the secondary bus only when the reconfigured grant signal, `s_req_1<0>`, is asserted and the secondary bus is idle.

10.0 General-Purpose I/O Interface

The 21150 implements a 4-pin general-purpose I/O gpio interface. During normal operation, the gpio interface is controlled by device-specific configuration registers. In addition, the gpio interface can be used for the following functions:

- During secondary interface reset, the gpio interface can be used to shift in a 16-bit serial stream that serves as a secondary bus clock disable mask.
- A live insertion bit can be used, along with the gpio<3> pin, to bring the 21150 gracefully to a halt through hardware, permitting live insertion of option cards behind the 21150.

10.1 gpio Control Registers

During normal operation, the gpio interface is controlled by the following device-specific configuration registers:

- The gpio output data register
- The gpio output enable control register
- The gpio input data register

These registers consist of five 8-bit fields:

- Write-1-to-set output data field
- Write-1-to-clear output data field
- Write-1-to-set signal output enable control field
- Write-1-to-clear signal output enable control field
- Input data field

The bottom 4 bits of the output enable fields control whether each gpio signal is input only or bidirectional. Each signal is controlled independently by a bit in each output enable control field. If a 1 is written to the write-1-to-set field, the corresponding pin is activated as an output. If a 1 is written to the write-1-to-clear field, the output driver is tristated, and the pin is then input only. Writing zeros to these registers has no effect. The reset state for these signals is input only.

The input data field is read only and reflects the current value of the gpio pins. A type 0 configuration read operation to this address is used to obtain the values of these pins. All pins can be read at any time, whether configured as input only or as bidirectional.

The output data fields also use the write-1-to-set and write-1-to-clear method. If a 1 is written to the write-1-to-set field and the pin is enabled as an output, the corresponding gpio output is driven high. If a 1 is written to the write-1-to-clear field and the pin is enabled as an output, the corresponding gpio output is driven low. Writing zeros to these registers has no effect. The value written to the output register will be driven only when the gpio signal is configured as bidirectional. A type 0 configuration write operation is used to program these fields. The reset value for the output is 0.

10.2 Secondary Clock Control

The 21150 uses the gpio pins and the msk_in signal to input a 16-bit serial data stream. This data stream is shifted into the secondary clock control register and is used for selectively disabling secondary clock outputs.

The serial data stream is shifted in as soon as p_rst_l is detected deasserted and the secondary reset signal, s_rst_l, is detected asserted. The deassertion of s_rst_l is delayed until the 21150 completes shifting in the clock mask data, which takes 23 clock cycles. After that, the gpio pins can be used as general-purpose I/O pins.

An external shift register should be used to load and shift the data. The gpio pins are used for shift register control and serial data input. Table 32 shows the operation of the gpio pins.

Table 32. gpio Operation

gpio Pin	Operation
gpio<0>	Shift register clock output at 33 MHz maximum frequency
gpio<1>	Not used
gpio<2>	Shift register control 0—Load 1—Shift
gpio<3>	Not used

The data is input through the dedicated input signal, msk_in.

The shift register circuitry is not necessary for correct operation of the 21150. The shift registers can be eliminated, and msk_in can be tied low to enable all secondary clock outputs or tied high to force all secondary clock outputs high.

Table 33 shows the format of the serial stream.

Table 33. gpio Serial Data Format

Bit	Description	s_clk_o Output
<1:0>	Slot 0 PRSNT#<1:0> or device 0	0
<3:2>	Slot 1 PRSNT#<1:0> or device 1	1
<5:4>	Slot 2 PRSNT#<1:0> or device 2	2
<7:6>	Slot 3 PRSNT#<1:0> or device 3	3
<8>	Device 4	4
<9>	Device 5	5
<10>	Device 6	6
<11>	Device 7	7
<12>	Device 8	8
<13>	21150 s_clk input	9
<14>	Reserved	Not applicable
<15>	Reserved	Not applicable

The first 8 bits contain the PRSNT#<1:0> signal values for four slots, and these bits control the s_clk_o<3:0> outputs. If one or both of the PRSNT#<1:0> signals are 0, that indicates that a card is present in the slot and therefore the secondary clock for that slot is not masked. If these clocks are connected to devices and not to slots, one or both of the bits should be tied low to enable the clock.

The next 5 bits are the clock mask for devices; each bit enables or disables the clock for one device. These bits control the s_clk_o<8:4> outputs: 0 enables the clock, and 1 disables the clock.

Bit 13 is the clock enable bit for s_clk_o<9>, which is connected to the 21150's s_clk input.

If desired, the assignment of s_clk_o clock outputs to slots, devices, and the 21150's s_clk input can be rearranged from the assignment shown here. However, it is important that the serial data stream format match the assignment of s_clk_o outputs.

The gpio pin serial protocol is designed to work with two 74F166 8-bit shift registers.

Figure 19 shows how the serial mask circuitry may be implemented for a motherboard with four slots.

Figure 19. Example of gpio Clock Mask Implementation on the System Board

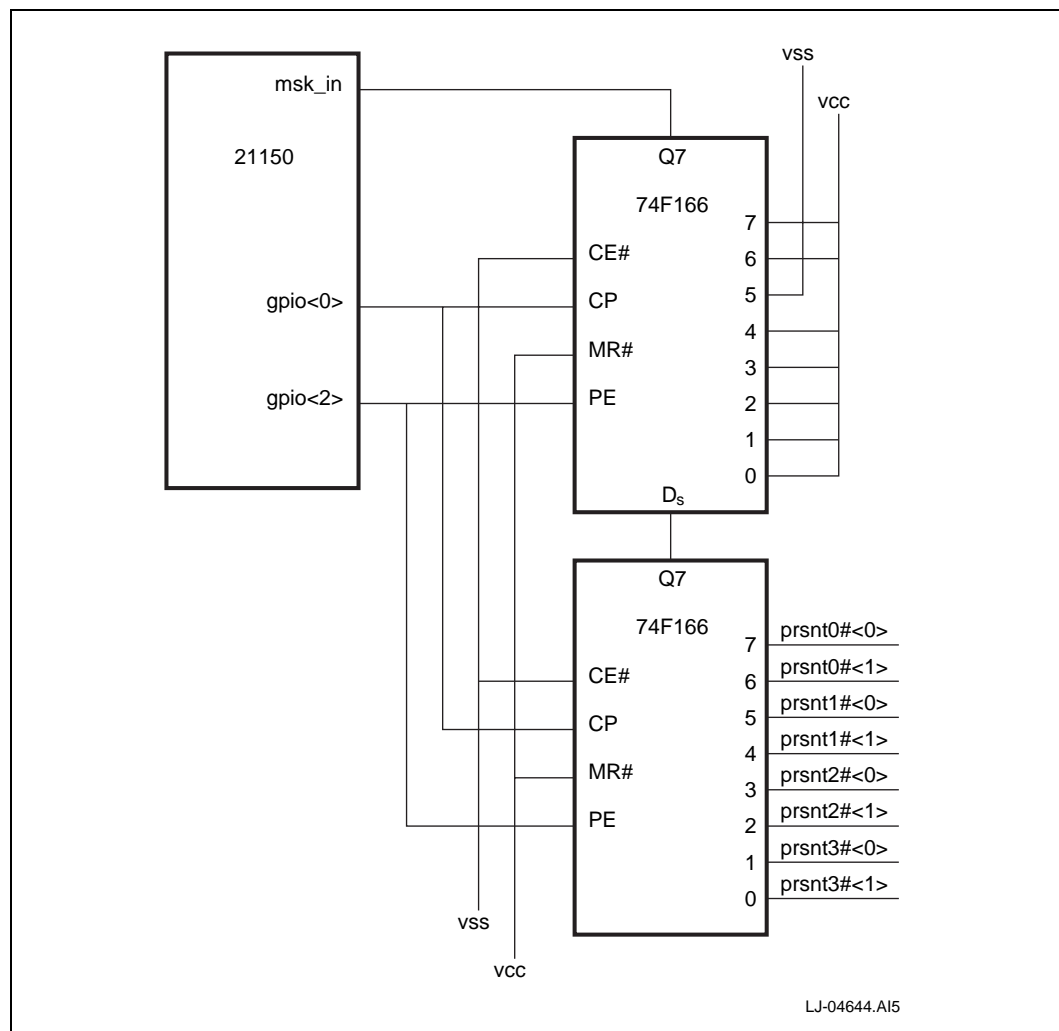

The 8 least significant bits are connected to the PRSNT# pins for the slots. The next 5 bits are tied high to disable their respective secondary clocks because those clocks are not connected to anything. The next bit is tied low because that secondary clock output is connected to the 21150 s_clk input.

When the secondary reset signal, s_rst_l, is detected asserted and the primary reset signal, p_rst_l, is detected deasserted, the 21150 drives gpio<2> low for one cycle to load the clock mask inputs into the shift register. On the next cycle, the 21150 drives gpio<2> high to perform a shift operation. This shifts the clock mask into msk_in; the most significant bit is shifted in first, and the least significant bit is shifted in last.

Figure 20 shows a timing diagram for the load and for the beginning of the shift operation.

Figure 20. Clock Mask Load and Shift Timing

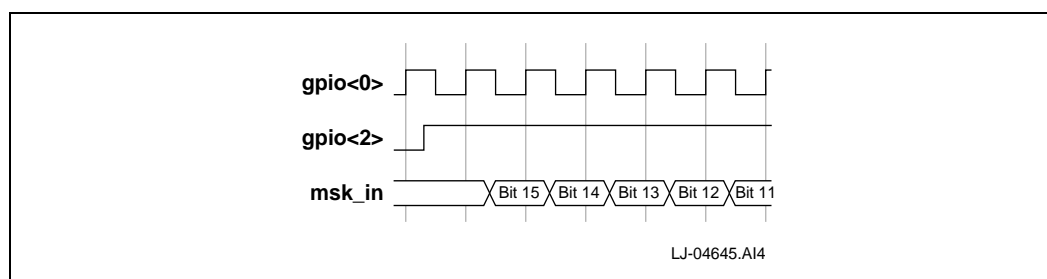

After the shift operation is complete, the 21150 tristates the gpio signals and can deassert s_rst_l if the secondary reset bit is clear. The 21150 then ignores msk_in. Control of the gpio signal now reverts to the 21150 gpio control registers. The clock disable mask can be modified subsequently through a configuration write command to the secondary clock control register in device-specific configuration space.

10.3 Live Insertion

The gpio<3> pin can be used, along with a live insertion mode bit, to disable transaction forwarding.

To enable live insertion mode, the live insertion mode bit in the chip control register must be set to 1, and the output enable control for gpio<3> must be set to input only in the gpio output enable control register. When live insertion mode is enabled, whenever gpio<3> is driven to a value of 1, the I/O enable, the memory enable, and the master enable bits are internally masked to 0. This means that, as a target, the 21150 no longer accepts any I/O or memory transactions, on either interface. When read, the register bits still reflect the value originally written by a configuration write command; when gpio<3> is deasserted, the internal enable bits return to their original value (as they appear when read from the command register). When this mode is enabled, as a master, the 21150 completes any posted write or delayed request transactions that have already been queued.

Delayed completion transactions are not returned to the master in this mode because the 21150 is not responding to any I/O or memory transactions during this time.

Note that the 21150 continues to accept configuration transactions in live insertion mode.

Once live insertion mode brings the 21150 to a halt and queued transactions are completed, the secondary reset bit in the bridge control register can be used to assert `s_rst_1`, if desired, to reset and tristate secondary bus devices, and to enable any live insertion hardware.

11.0 Clocks

This chapter provides information about the 21150 clocks.

11.1 Primary and Secondary Clock Inputs

The 21150 implements a separate clock input for each PCI interface. The primary interface is synchronized to the primary clock input, p_clk, and the secondary interface is synchronized to the secondary clock input, s_clk.

The 21150 operates at a maximum frequency of 33 MHz, or 66 MHz if the 21150 is 66 MHz capable. s_clk operates either at the same frequency or at half the frequency as p_clk.

The primary and secondary clock inputs must always maintain a synchronous relationship to each other; that is, their edge relationships to each other are well defined. The maximum skew between p_clk and s_clk rising edges is 7 ns, as is the maximum skew between p_clk and s_clk falling edges. The minimum skew between p_clk and s_clk edges is 0 ns. The secondary clock edge must never precede the primary clock edge. [Figure 21](#) illustrates the timing relationship between the primary and the secondary clock inputs.

Figure 21. p_clk and s_clk Relative Timing

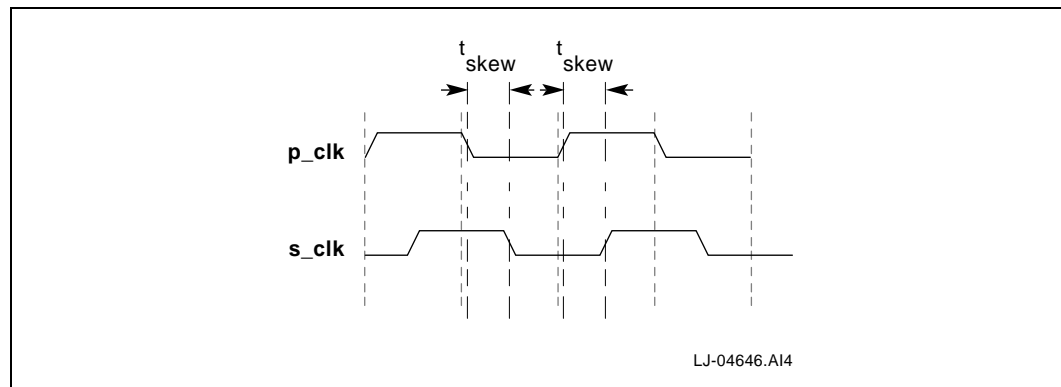

11.2 Secondary Clock Outputs

The 21150 has 10 secondary clock outputs, s_clk_o<9:0>, that can be used as clock inputs for up to nine external secondary bus devices and for the 21150 secondary clock input.

The s_clk_o outputs are derived from p_clk. The s_clk_o edges are delayed from p_clk edges by a minimum of 0 ns and a maximum of 5 ns. The maximum skew between s_clk_o edges is 500 ps. Therefore, to meet the p_clk and s_clk requirements stated in [Section 11.1](#), no more than 2 ns of delay is allowed for secondary clock each returning to the device secondary clock inputs.

The rules for using secondary clocks are:

- Each secondary clock output is limited to one load.
- One of the secondary clock outputs must be used for the 21150 s_clk input.

- DIGITAL recommends using an equivalent amount of etch on the board for all secondary clocks, to minimize skew between them, and a maximum delay of the etch of 2 ns.
- DIGITAL recommends terminating or disabling unused secondary clock outputs to reduce power dissipation and noise in the system.

11.3 Disabling Unused Secondary Clock Outputs

When secondary clock outputs are not used, both `gpio<3:0>` and `msk_in` can be used to clock in a serial mask that selectively tristates secondary clock outputs. [Section 10.2](#) describes how the 21150 uses the `gpio` pins and the `msk_in` signal to input this data stream.

After the serial mask has been shifted into the 21150, the value of the mask is readable and modifiable in the secondary clock disable mask register. When the mask is modified by a configuration write operation to this register, the new clock mask disables the appropriate secondary clock outputs within a few cycles. This feature allows software to disable or enable secondary clock outputs based on the presence of option cards, and so on.

The 21150 delays deasserting the secondary reset signal, `s_rst_l`, until the serial clock mask has been completely shifted in and the secondary clocks have been disabled or enabled, according to the mask. The delay between `p_rst_l` deassertion and `s_rst_l` deassertion is approximately 23 cycles (46 cycles if `s_clk` is operating at 66 MHz).

12.0 66-Mhz Operation

Some versions of the 21150 support 66 MHz operation. All 21150 versions marked 21150-Bx are 66MHz capable. Versions of the 21150 marked 21150-Ax are not capable of operation at 66 MHz.

Signal config66 must be tied high on the board to enable 66 MHz operation and to set the 66 MHz Capable bit in the Status register and Secondary Status register in configuration space. If the 21150 version is not 66MHz capable, then config66 should be tied low. Signals p_m66ena and s_m66ena should never be pulled high unless config66 is also high.

Signals p_m66ena and s_m66ena indicate whether the primary and secondary interfaces, respectively, are operating at 66 MHz¹. This information is needed to control the frequency of the secondary bus. Note that the *PCI Local Bus Specification, Revision 2.1* restricts clock frequency changes above 33 MHz to during PCI reset only.

The 66Mhz capable 21150 supports the following primary and secondary bus frequency combinations:

- 66 MHz primary bus, 66 MHz secondary bus
- 66 MHz primary bus, 33 MHz secondary bus
- 33 MHz primary bus, 33 MHz secondary bus

The 21150 does not support 33 MHz primary/66 MHz secondary bus operation, where the secondary bus is operating at twice the frequency of the primary bus. If config66 is high and p_m66ena is low (66 MHz capable, primary bus at 33MHz), then the 21150 pulls down s_m66ena to indicate that the secondary bus is operating at 33 MHz.

The 21150 generates the clock signals (s_clk_o<9:0>) for the secondary bus devices and its own secondary interface. The 21150 divides the primary bus clock p_clk by two to generate the secondary bus clock outputs whenever the primary bus is operating at 66 MHz and the secondary bus is operating at 33 MHz. The bridge detects this condition when p_m66ena is high and s_m66ena is low.

¹ In general, 66-MHz operation means operation ranging from 33 MHz up to 66 MHz.

13.0 PCI Power Management

The 21150¹ incorporates functionality that meets the requirements of the *PCI Power Management Specification, Revision 1.0*. These features include:

- PCI Power Management registers using the Enhanced Capabilities Port (ECP) address mechanism
- Support for D0, D3_{hot} and D3_{cold} power management states
- Support for D0, D1, D2, D3_{hot}, and D3_{cold} power management states for devices behind the bridge
- Support of the B2 secondary bus power state when in the D3_{hot} power management state

Table 34 shows the states and related actions that the 21150 performs during power management transitions. (No other transactions are permitted.)

Table 34. Power Management Transitions

Current State	Next State	Action
D0	D3 _{cold}	Power has been removed from the 21150. A power-up reset must be performed to bring the 21150 to D0.
D0	D3 _{hot}	If enabled to do so by the bpcce pin, the 21150 will disable the secondary clocks and drive them low.
D0	D2	Unimplemented power state. The 21150 will ignore the write to the power state bits (power state remains at D0).
D0	D1	Unimplemented power state. The 21150 will ignore the write to the power state bits (power state remains at D0).
D3 _{hot}	D0	The 21150 enables secondary clock outputs and performs an internal chip reset. Signal s_rst_! will not be asserted. All registers will be returned to the reset values and buffers will be cleared.
D3 _{hot}	D3 _{cold}	Power has been removed from the 21150. A power-up reset must be performed to bring the 21150 to D0.
D3 _{cold}	D0	Power-up reset. The 21150 performs the standard power-up reset functions as described in Chapter 13.

PME# signals are routed from downstream devices *around* PCI-to-PCI bridges. PME# signals do not pass through PCI-to-PCI bridges.

1. The 21150-AA *does not* include these features.

14.0 Reset

This chapter describes the primary interface, secondary interface, and chip reset mechanisms.

14.1 Primary Interface Reset

The 21150 has one reset input, `p_rst_l`.

When `p_rst_l` is asserted, the following events occur:

- The 21150 immediately tristates all primary and secondary PCI interface signals.
- The 21150 performs a chip reset.
- Registers that have default values are reset.
Appendix A lists the values of all configuration space registers after reset.

The `p_rst_l` asserting and deasserting edges can be asynchronous to `p_clk` and `s_clk`.

14.2 Secondary Interface Reset

The 21150 is responsible for driving the secondary bus reset signal, `s_rst_l`. The 21150 asserts `s_rst_l` when any of the following conditions is met:

- Signal `p_rst_l` is asserted.
Signal `s_rst_l` remains asserted as long as `p_rst_l` is asserted and does not deassert until `p_rst_l` is deasserted and the secondary clock serial disable mask has been shifted in (23 or 46 clock cycles after `p_rst_l` deassertion).
- The secondary reset bit in the bridge control register is set.
Signal `s_rst_l` remains asserted until a configuration write operation clears the secondary reset bit and the secondary clock serial mask has been shifted in.
- The chip reset bit in the diagnostic control register is set.

Signal `s_rst_l` remains asserted until a configuration write operation clears the secondary reset bit and the secondary clock serial mask has been shifted in.

When `s_rst_l` is asserted, all secondary PCI interface control signals, including the secondary grant outputs, are immediately tristated. Signals `s_ad`, `s_cbe_l`, and `s_par` are driven low for the duration of `s_rst_l` assertion. All posted write and delayed transaction data buffers are reset; therefore, any transactions residing in 21150 buffers at the time of secondary reset are discarded.

When `s_rst_l` is asserted by means of the secondary reset bit, the 21150 remains accessible during secondary interface reset and continues to respond to accesses to its configuration space from the primary interface.

14.3 Chip Reset

The chip reset bit in the diagnostic control register can be used to reset the 21150 and the secondary bus.

When the chip reset bit is set, all registers and chip state are reset and all signals are tristated. In addition, `s_rst_l` is asserted, and the secondary reset bit is automatically set. Signal `s_rst_l` remains asserted until a configuration write operation clears the secondary reset bit and the serial clock mask has been shifted in.

As soon as chip reset completes, within 20 PCI clock cycles after completion of the configuration write operation that sets the chip reset bit, the chip reset bit automatically clears and the chip is ready for configuration.

During chip reset, the 21150 is inaccessible.

15.0 Configuration Space Registers

This chapter provides a detailed description of the 21150 configuration space registers. The chapter is divided into three sections: [Section 15.1](#) describes the standard 21150 PCI-to-PCI bridge configuration registers, [Section 15.2](#) describes the 21150 device-specific configuration registers, and [Section 15.3](#) describes the configuration register values after reset.

The 21150 configuration space uses the PCI-to-PCI bridge standard format specified in the *PCI-to-PCI Bridge Architecture Specification*. The header type at configuration address 0Eh reads as 01h, indicating that this device uses the PCI-to-PCI bridge format.

The 21150 also contains device-specific registers, starting at address 40h. Use of these registers is not required for standard PCI-to-PCI bridge implementations.

The configuration space registers can be accessed only from the primary PCI bus. To access a register, perform a Type 0 format configuration read or write operation to that register. During the Type 0 address phase, p_ad<7:2> indicates the Dword offset of the register. During the data phase, p_cbe_l<3:0> selects the bytes in the Dword that is being accessed.

Caution: Software changes the configuration register values that affect 21150 behavior only during initialization. Change these values subsequently only when both the primary and secondary PCI buses are idle, and the data buffers are empty; otherwise, the behavior of the 21150 is unpredictable.

[Figure 22](#) shows a summary of the configuration space.

Figure 22. 21150 Configuration Space

31		16 15		00		
Device ID		Vendor ID				00h
Primary Status		Primary Command				04h
Class Code			Revision ID			08h
Reserved	Header Type	Primary Latency Timer	Cache Line Size			0Ch
Reserved						10h
Reserved						14h
Secondary Latency Timer	Subordinate Bus Number	Secondary Bus Number	Primary Bus Number			18h
Secondary Status		I/O Limit Address	I/O Base Address			1Ch
Memory Limit Address		Memory Base Address				20h
Prefetchable Memory Limit Address		Prefetchable Memory Base Address				24h
Prefetchable Memory Base Address Upper 32 Bits						28h
Prefetchable Memory Limit Address Upper 32 Bits						2Ch
I/O Limit Address Upper 16 Bits			I/O Base Address Upper 16 Bits			30h
Reserved*				ECP Pointer*		34h
Reserved						38h
Bridge Control		Interrupt Pin	Reserved			3Ch
Arbiter Control		Diagnostic Control	Chip Control			40h
Reserved						44h-60h
gpio Input Data	gpio Output Enable Control	gpio Output Data	p_serr_I Event Disable			64h
Reserved	p_serr_I Status	Secondary Clock Control				68h
Reserved						6Ch-DBh
Power Management Capabilities**		Next Item Ptr**	Capability ID**			DCh
Data	PPB Support Extensions**	Power Management CSR**				E0h
Reserved						E4h-FFh

* In the 21150-AA only, these registers are R/W: Subsystem ID and Subsystem Vendor ID.
 ** These are reserved for the 21150-AA.

LJ-06238.AI4

15.1 PCI-to-PCI Bridge Standard Configuration Registers

This section provides a detailed description of the PCI-to-PCI bridge standard configuration registers.

Each field has a separate description.

Fields that have the same configuration Dword address are selectable by turning on (driving low) the appropriate byte enable bits on p_cbe_l during the data phase. To select all fields of a configuration address, drive all byte enable bits low.

All reserved fields and registers are read only and always return 0.

15.1.1 Vendor ID Register—Offset 00h

This section describes the vendor ID register.

Dword address = 00h

Byte enable p_cbe_l<3:0> = xx00b

Dword Bit	Name	R/W	Description
15:0	Vendor ID	R	Identifies the vendor of this device. Internally hardwired to be 1011h

15.1.2 Device ID Register—Offset 02h

This section describes the device ID register.

Dword address = 00h

Byte enable p_cbe_l<3:0> = 00xxb

Dword Bit	Name	R/W	Description
31:16	Device ID	R	Identifies this device as the 21150. Internally hardwired to be 22h.

15.1.3 Primary Command Register—Offset 04h

This section describes the primary command register.

These bits affect the behavior of the 21150 primary interface, except where noted. Some of the bits are repeated in the bridge control register, to act on the secondary interface.

This register must be initialized by configuration software.

Dword address = 04h

Byte enable p_cbe_l<3:0> = xx00b

Dword Bit	Name	R/W	Description
0	I/O space enable	R/W	Controls the 21150's response to I/O transactions on the primary interface. When 0—The 21150 does not respond to I/O transactions initiated on the primary bus. When 1—The 21150 response to I/O transactions initiated on the secondary bus is enabled. Reset value: 0.
1	Memory space enable	R/W	Controls the 21150's response to memory transactions on the 21150 primary interface. When 0—The 21150 does not respond to memory transactions initiated on the primary bus. When 1—The 21150 response to memory transactions initiated on the primary bus is enabled. Reset value: 0.
2	Master enable	R/W	Controls the 21150's ability to initiate memory and I/O transactions on the primary bus on behalf of an initiator on the secondary bus. Forwarding of configuration transactions is not affected. When 0—The 21150 does not respond to I/O or memory transactions on the secondary interface and does not initiate I/O or memory transactions on the primary interface. When 1—The 21150 is enabled to operate as an initiator on the primary bus and responds to I/O and memory transactions initiated on the secondary bus. Reset value: 0.
3	Special cycle enable	R	The 21150 ignores special cycle transactions, so this bit is read only and returns 0.
4	Memory write and invalidate enable	R	The 21150 generates memory write and invalidate transactions only when operating on behalf of another master whose memory write and invalidate transaction is crossing the 21150. This bit is read only and returns 0.
5	VGA snoop enable	R/W	Controls the 21150's response to VGA-compatible palette write transactions. VGA palette write transactions correspond to I/O transactions whose address bits are as follows: <ul style="list-style-type: none"> • p_ad<9:0> are equal to 3C6h, 3C8h, and 3C9h. • p_ad<15:10> are not decoded. • p_ad<31:16> must be 0. When 0—VGA palette write transactions on the primary interface are ignored unless they fall inside the 21150's I/O address range. When 1—VGA palette write transactions on the primary interface are positively decoded and forwarded to the secondary interface. Reset value: 0.

Dword Bit	Name	R/W	Description
6	Parity error response	R/W	Controls the 21150's response when a parity error is detected on the primary interface. When 0—The 21150 does not assert p_perr_l, nor does it set the data parity reported bit in the status register. The 21150 does not report address parity errors by asserting p_serr_l. When 1—The 21150 drives p_perr_l and conditionally sets the data parity reported bit in the status register when a data parity error is detected (see Section 7.0). The 21150 allows p_serr_l assertion when address parity errors are detected on the primary interface. Reset value: 0.
7	Wait cycle control	R	Reads as 0 to indicate that the 21150 does not perform address or data stepping.
8	SERR# enable	R/W	Controls the enable for p_serr_l on the primary interface. When 0—Signal p_serr_l cannot be driven by the 21150. When 1—Signal p_serr_l can be driven low by the 21150 under the conditions described in Section 7.4 . Reset value: 0.
9	Fast back-to-back enable	R/W	Controls the ability of the 21150 to generate fast back-to-back transactions on the primary bus. When 0—The 21150 does not generate back-to-back transactions on the primary bus. When 1—The 21150 is enabled to generate back-to-back transactions on the primary bus. Reset value: 0.
15;10	Reserved	R	Reserved. Returns 0 when read.

15.1.4 Primary Status Register—Offset 06h

This section describes the primary status register.

These bits affect the status of the 21150 primary interface. Bits reflecting the status of the secondary interface are found in the secondary status register. WITC indicates that writing 1 to a bit sets that bit to 0. Writing 0 has no effect.

Dword address = 04h

Byte enable p_cbe_l<3:0> = 00xb

Dword Bit	Name	R/W	Description
19:16	Reserved	R	Reserved. Returns 0 when read.
20	ECP	R	Enhanced Capabilities Port (ECP) enable. Reads as 1 in the 21150-AB and later revisions to indicate that the 21150-AB supports an enhanced capabilities list. The 21150-AA reads as 0 to show that this capability is not supported.
21	66-MHz capable	R	Indicates whether the primary interface is 66-MHz capable. Reads as 0 when pin config66 is tied low to indicate that the 21150 is not 66 MHz capable. Reads as 1 when pin config66 is tied high to indicate that the primary bus is 66 MHz capable.
22	Reserved	R	Reserved. Returns 0 when read.
23	Fast back-to-back capable	R	Reads as 1 to indicate that the 21150 is able to respond to fast back-to-back transactions on the primary interface.
24	Data parity detected	R/W1TC	This bit is set to 1 when all of the following are true: <ul style="list-style-type: none"> The 21150 is a master on the primary bus. Signal p_perr_l is detected asserted, or a parity error is detected on the primary bus. The parity error response bit is set in the command register. Reset value: 0.
26:25	DEVSEL# timing	R	Indicates slowest response to a nonconfiguration command on the primary interface. Reads as 01b to indicate that the 21150 responds no slower than with medium timing.
27	Signaled target abort	R/W1TC	This bit is set to 1 when the 21150 is acting as a target on the primary bus and returns a target abort to the primary master. Reset value: 0.
28	Received target abort	R/W1TC	This bit is set to 1 when the 21150 is acting as a master on the primary bus and receives a target abort from the primary target. Reset value: 0.
29	Received master abort	R/W1TC	This bit is set to 1 when the 21150 is acting as a master on the primary bus and receives a master abort. Reset value: 0.
30	Signaled system error	R/W1TC	This bit is set to 1 when the 21150 has asserted p_serr_l. Reset value: 0.
31	Detected parity error	R/W1TC	This bit is set to 1 when the 21150 detects an address or data parity error on the primary interface. Reset value: 0.

15.1.5 Revision ID Register—Offset 08h

This section describes the revision ID register.

Dword address = 08h

Byte enable p_cbe_l<3:0> = xxx0b

Dword Bit	Name	R/W	Description
7:0	Revision ID	R	Indicates the revision number of this device. The initial revision reads as 0. Subsequent revisions increment by 1.

15.1.6 Programming Interface Register—Offset 09h

This section describes the programming interface register.

Dword address = 08h

Byte enable p_cbe_l<3:0> = xx0xb

Dword Bit	Name	R/W	Description
15:8	Programming interface	R	No programming interfaces have been defined for PCI-to-PCI bridges. Reads as 0.

15.1.7 Subclass Code Register—Offset 0Ah

This section describes the subclass code register.

Dword address = 08h

Byte enable p_cbe_l<:0> = x0xxb

Dword Bit	Name	R/W	Description
23:16	Subclass code	R	Reads as 04h to indicate that this bridge device is a PCI-to-PCI bridge.

15.1.8 Base Class Code Register—Offset 0Bh

This section describes the base class code register.

Dword address = 08h

Byte enable p_cbe_l<3> = 0xxb

Dword Bit	Name	R/W	Description
31:24	Base class code	R	Reads as 06h to indicate that this device is a bridge device.

15.1.9 Cache Line Size Register—Offset 0Ch

This section describes the cache line size register.

Dword address = 0Ch

Byte enable p_cbe_l<3:0> = xxx0b

Dword Bit	Name	R/W	Description
7:0	Cache line size	R/W	Designates the cache line size for the system in units of 32-bit Dwords. Used for prefetching memory read transactions and for terminating memory write and invalidate transactions. The cache line size should be written as a power of 2. If the value is not a power of 2 or is greater than 16, the 21150 behaves as if the cache line size were 0. Reset value: 0.

15.1.10 Primary Latency Timer Register—Offset 0Dh

This section describes the primary latency timer register.

Dword address = 0Ch

Byte enable p_cbe_l<3:0> = xx0xb

Dword Bit	Name	R/W	Description
15:8	Master latency timer	R/W	Master latency timer for the primary interface. Indicates the number of PCI clock cycles from the assertion of p_frame_l to the expiration of the timer when the 21150 is acting as a master on the primary interface. All bits are writable, resulting in a granularity of one PCI clock cycle. When 0—The 21150 relinquishes the bus after the first data transfer when the 21150's primary bus grant has been deasserted, with the exception of memory write and invalidate transactions. Reset value: 0.

15.1.11 Header Type Register—Offset 0Eh

This section describes the header type register.

Dword address = 0Ch

Byte enable p_cbe_l<3:0> = x0xxb

Dword Bit	Name	R/W	Description
23:16	Header type	R	Defines the layout of addresses 10h through 3Fh in configuration space. Reads as 01h to indicate that the register layout conforms to the standard PCI-to-PCI bridge layout.

15.1.12 Primary Bus Number Register—Offset 18h

This section describes the primary bus number register.

This register must be initialized by configuration software.

Dword address = 18h

Byte enable p_cbe_l<3:0> = xxx0b

Dword Bit	Name	R/W	Description
7:0	Primary bus number	R/W	Indicates the number of the PCI bus to which the primary interface is connected. The 21150 uses this register to decode Type 1 configuration transactions on the secondary interface that should either be converted to special cycle transactions on the primary interface or passed upstream unaltered. Reset value: 0.

15.1.13 Secondary Bus Number Register—Offset 19h

This section describes the secondary bus number register.

This register must be initialized by configuration software.

Dword address = 18h

Byte enable p_cbe_l<3:0>= xx0xb

Dword Bit	Name	R/W	Description
15:8	Secondary bus number	R/W	Indicates the number of the PCI bus to which the secondary interface is connected. The 21150 uses this register to determine when to respond to and forward Type 1 configuration transactions on the primary interface, and to determine when to convert them to Type 0 or special cycle transactions on the secondary interface. Reset value: 0.

15.1.14 Subordinate Bus Number Register—Offset 1Ah

This section describes the subordinate bus number register.

This register must be initialized by configuration software.

Dword address = 18h

Byte enable p_cbe_l<3:0>= x0xxb

Dword Bit	Name	R/W	Description
23:16	Subordinate bus number	R/W	Indicates the number of the highest numbered PCI bus that is behind (or subordinate to) the 21150. Used in conjunction with the secondary bus number to determine when to respond to Type 1 configuration transactions on the primary interface and pass them to the secondary interface as a Type 1 configuration transaction. Reset value: 0.

15.1.15 Secondary Latency Timer Register—Offset 1Bh

This section describes the secondary latency timer register.

Dword address = 18h

Byte enable p_cbe_l<3:0> = 0xxxb

Dword Bit	Name	R/W	Description
31:24	Secondary latency timer	R/W	Master latency timer for the secondary interface. Indicates the number of PCI clock cycles from the assertion of s_frame_l to the expiration of the timer when the 21150 is acting as a master on the secondary interface. All bits are writable, resulting in a granularity of one PCI clock cycle. When 0—The 21150 ends the transaction after the first data transfer when the 21150's secondary bus grant has been deasserted, with the exception of memory write and invalidate transactions. Reset value: 0.

15.1.16 I/O Base Address Register—Offset 1Ch

This section describes the I/O base address register.

This register must be initialized by configuration software.

Dword address = 1Ch

Byte enable p_cbe_l<3:0> = xxx0b

Dword Bit	Name	R/W	Description
3:0	32-bit indicator	R	The low 4 bits of this register read as 1h to indicate that the 21150 supports 32-bit I/O address decoding.
7:4	I/O base address <15:12>	R/W	Defines the bottom address of an address range used by the 21150 to determine when to forward I/O transactions from one interface to the other. The upper 4 bits are writable and correspond to address bits <15:12>. The lower 12 bits of the address are assumed to be 0. The upper 16 bits corresponding to address bits <31:16> are defined in the I/O base address upper 16 bits register. The I/O address range adheres to 4 KB alignment and granularity. Reset value: 0.

15.1.17 I/O Limit Address Register—Offset 1Dh

This section describes the I/O limit address register.

This register must be initialized by configuration software.

Dword address = 1Ch

Byte enable p_cbe_l<3:0> = xx0xb

Dword Bit	Name	R/W	Description
11:8	32-bit indicator	R/W	The low 4 bits of this register read as 1h to indicate that the 21150 supports 32-bit I/O address decoding.
15:12	I/O limit address <15:12>	R/W	Defines the top address of an address range used by the 21150 to determine when to forward I/O transactions from one interface to the other. The upper 4 bits are writable and correspond to address bits <15:12>. The lower 12 bits of the address are assumed to be FFFh. The upper 16 bits corresponding to address bits <31:16> are defined in the I/O limit address upper 16 bits register. The I/O address range adheres to 4KB alignment and granularity. Reset value: 0.

15.1.18 Secondary Status Register—Offset 1Eh

This section describes the secondary status register.

These bits reflect the status of the 21150 secondary interface. WITC indicates that writing 1 to that bit sets the bit to 0. Writing 0 has no effect.

Dword address = 1Ch

Byte enable p_cbe_l<3:0> = 00xxb

Dword Bit	Name	R/W	Description
20:16	Reserved	R	Reserved. Returns 0 when read.
21	66-MHz capable	R	Indicates whether the secondary interface is 66-MHz capable. Reads as 0 when pin config66 is tied low to indicate that the 21150 is not 66 MHz capable. Reads as 1 when pin config66 is tied high to indicate that the secondary bus is 66 MHz capable.
22	Reserved	R	Reserved. Returns 0 when read.
23	Fast back-to-back capable	R	Reads as 1 to indicate that the 21150 is able to respond to fast back-to-back transactions on the secondary interface.
24	Data parity detected	R/W1TC	This bit is set to 1 when all of the following are true: <ul style="list-style-type: none"> The 21150 is a master on the secondary bus. Signal s_perr_l is detected asserted, or a parity error is detected on the secondary bus. The parity error response bit is set in the bridge control register. Reset value: 0.
26:25	DEVSEL# timing	R	Indicates slowest response to a command on the secondary interface. Reads as 01b to indicate that the 21150 responds no slower than with medium timing.
27	Signaled target abort	R/W1TC	This bit is set to 1 when the 21150 is acting as a target on the secondary bus and returns a target abort to the secondary bus master. Reset value: 0.
28	Received target abort	R/W1TC	This bit is set to 1 when the 21150 is acting as a master on the secondary bus and receives a target abort from the secondary bus target. Reset value: 0.
29	Received master abort	R/W1TC	This bit is set to 1 when the 21150 is acting as an initiator on the secondary bus and receives a master abort. Reset value: 0.
30	Received system error	R/W1TC	This bit is set to 1 when the 21150 detects the assertion of s_serr_l on the secondary interface. Reset value: 0.
31	Detected parity error	R/W1TC	This bit is set to 1 when the 21150 detects an address or data parity error on the secondary interface. Reset value: 0.

15.1.19 Memory Base Address Register—Offset 20h

This section describes the memory base address register.

This register must be initialized by configuration software.

Dword address = 20h

Byte enable p_cbe_l<3:0> = xx00b

Dword Bit	Name	R/W	Description
3:0	Reserved	R	The low 4 bits of this register are read only and return 0.
15:4	Memory base address <31:20>	R/W	Defines the bottom address of an address range used by the 21150 to determine when to forward memory transactions from one interface to the other. The upper 12 bits are writable and correspond to address bits <31:20>. The lower 20 bits of the address are assumed to be 0. The memory address range adheres to 1MB alignment and granularity. Reset value: 0.

15.1.20 Memory Limit Address Register—Offset 22h

This section describes the memory limit address register.

This register must be initialized by configuration software.

Dword address = 20h

Byte enable p_cbe_l<3:0> = 00xxb

Dword Bit	Name	R/W	Description
19:16	Reserved	R	The low 4 bits of this register are read only and return 0.
31:20	Memory limit address <31:20>	R/W	Defines the top address of an address range used by the 21150 to determine when to forward memory transactions from one interface to the other. The upper 12 bits are writable and correspond to address bits <31:20>. The lower 20 bits of the address are assumed to be FFFFh. The memory address range adheres to 1MB alignment and granularity. Reset value: 0.

15.1.21 Prefetchable Memory Base Address Register—Offset 24h

This section describes the prefetchable memory base address register.

This register must be initialized by configuration software.

Dword address = 24h

Byte enable p_cbe_l<3:0> = xx00b

Dword Bit	Name	R/W	Description
3:0	64-bit indicator	R	The low 4 bits of this register are read only and return 1h to indicate that this range supports 64-bit addressing.
15:4	Prefetchable memory base address <31:20>	R/W	Defines the bottom address of an address range used by the 21150 to determine when to forward memory read and write transactions from one interface to the other. The upper 12 bits are writable and correspond to address bits <31:20>. The lower 20 bits of the address are assumed to be 0. The memory base register upper 32 bits contains the upper half of the base address. The memory address range adheres to 1MB alignment and granularity. Reset value: 0.

15.1.22 Prefetchable Memory Limit Address Register—Offset 26h

This section describes the prefetchable memory limit address register.

This register must be initialized by configuration software.

Dword address = 24h

Byte enable p_cbe_l<3:0> = 00xxb

Dword Bit	Name	R/W	Description
19:16	64-bit indicator	R	The low 4 bits of this register are read only and return 1h to indicate that this range supports 64-bit addressing.
31:20	Prefetchable memory limit address <31:20>	R/W	Defines the top address of an address range used by the 21150 to determine when to forward memory read and write transactions from one interface to the other. The upper 12 bits are writable and correspond to address bits <31:20>. The lower 20 bits of the address are assumed to be FFFFh. The memory limit upper 32 bits register contains the upper half of the limit address. The memory address range adheres to 1MB alignment and granularity. Reset value: 0.

15.1.23 Prefetchable Memory Base Address Upper 32 Bits Register—Offset 28h

This section describes the prefetchable memory base address upper 32 bits register.

This register must be initialized by configuration software.

Dword address = 28h

Byte enable p_cbe_l<3:0>= 0000b

Dword Bit	Name	R/W	Description
31:0	Upper 32 prefetchable memory base address <63:32>	R/W	Defines the upper 32 bits of a 64-bit bottom address of an address range used by the 21150 to determine when to forward memory read and write transactions from one interface to the other. The memory address range adheres to 1MB alignment and granularity. Reset value: 0.

15.1.24 Prefetchable Memory Limit Address Upper 32 Bits Register—Offset 2Ch

This section describes the prefetchable memory limit address upper 32 bits register.

This register must be initialized by configuration software.

Dword address = 2Ch

Byte enable p_cbe_l<3:0> = 0000b

Dword Bit	Name	R/W	Description
31:0	Upper 32 prefetchable memory limit address <63:32>	R/W	Defines the upper 32 bits of a 64-bit top address of an address range used by the 21150 to determine when to forward memory read and write transactions from one interface to the other. Extra read transactions should have no side effects. The memory address range adheres to 1MB alignment and granularity. Reset value: 0.

15.1.25 I/O Base Address Upper 16 Bits Register—Offset 30h

This section describes the I/O base address upper 16 bits register.

This register must be initialized by configuration software.

Dword address = 30h

Byte enable p_cbe_l<3:0> = xx00b

Dword Bit	Name	R/W	Description
15:0	I/O base address upper 16 bits <31:16>	R/W	Defines the upper 16 bits of a 32-bit bottom address of an address range used by the 21150 to determine when to forward I/O transactions from one interface to the other. The I/O address range adheres to 4KB alignment and granularity. Reset value: 0.

15.1.26 I/O Limit Address Upper 16 Bits Register—Offset 32h

This section describes the I/O limit address upper 16 bits register.

This register must be initialized by configuration software.

Dword address = 30h

Byte enable p_cbe_l<3:0> = 00xxb

Dword Bit	Name	R/W	Description
31:16	I/O limit address upper 16 bits <31:16>	R/W	Defines the upper 16 bits of a 32-bit top address of an address range used by the 21150 to determine when to forward I/O transactions from one interface to the other. The I/O address range adheres to 4KB alignment and granularity. Reset value: 0.

15.1.27 Subsystem Vendor ID Register—Offset 34h

This section describes the subsystem vendor ID register.

Dword address = 34h

Byte enable p_cbe_l<3:0> = xx00b

Dword Bit	Name	R/W	Description
15:0	Subsystem vendor ID	R/W	Provides a mechanism allowing add-in cards to distinguish their cards from one another. The 21150 provides a writable subsystem vendor ID that can be initialized during POST. This register is only implemented in the 21150-AA. Reset to 0.

15.1.28 ECP Pointer Register—Offset 34h

This section describes the ECP pointer register.

Dword address = 34h

Byte enable p_cbe_l<3:0> = 0000b

Dword Bit	Name	R/W	Description
7:0	ECP_PTR	R	Enhanced Capabilities Port (ECP) offset pointer. Reads as DCh in the 21150-AB and later revisions to indicate that the first item, which corresponds to the power management registers, resides at that configuration offset. This is a R/W register with no side effects in the 21150-AA.
31:8	Reserved	R	Reserved. The 21150-AB and later revisions return 0 when read. This is a R/W register with no side effects in the 21150-AA.

15.1.29 Subsystem ID Register—Offset 36h

This section describes the subsystem ID register.

Dword address = 34h

Byte enable p_cbe_l<3:0> = 00xxb

Dword Bit	Name	R/W	Description
31:16	Subsystem ID	R/W	Provides a mechanism allowing add-in cards to distinguish their cards from one another. The 21150 provides a writable subsystem ID that can be initialized during POST. This register is only implemented in the 21150-AA. Reset to 0.

15.1.30 Interrupt Pin Register—Offset 3Dh

This section describes the interrupt pin register.

Dword address = 3Ch

Byte enable p_cbe_l<3:0> = xx0xb

Dword Bit	Name	R/W	Description
15:8	Interrupt pin	R	Reads as 0 to indicate that the 21150 does not have an interrupt pin.

15.1.31 Bridge Control Register—Offset 3Eh

This section describes the bridge control register.

This register must be initialized by configuration software.

Dword address = 3Ch

Byte enable p_cbe_l<3:0>= 00xxb

Dword Bit	Name	R/W	Description
16	Parity error response	R/W	Controls the 21150's response when a parity error is detected on the secondary interface. When 0—The 21150 does not assert s_perr_l, nor does it set the data parity reported bit in the secondary status register. The 21150 does not report address parity errors by asserting p_serr_l. When 1—The 21150 drives s_perr_l and conditionally sets the data parity reported bit in the secondary status register when a data parity error is detected on the secondary interface (see Section 7.0). Also must be set to 1 to allow p_serr_l assertion when address parity errors are detected on the secondary interface. Reset value: 0.

Dword Bit	Name	R/W	Description
17	SERR# forward enable	R/W	<p>Controls whether the 21150 asserts p_serr_l when it detects s_serr_l asserted.</p> <p>When 0—The 21150 does not drive p_serr_l in response to s_serr_l assertion.</p> <p>When 1—The 21150 asserts p_serr_l when s_serr_l is detected asserted (the primary SERR# driver enable bit must also be set).</p> <p>Reset value 0.</p>
18	ISA enable	R/W	<p>Modifies the 21150's response to ISA I/O addresses. Applies only to those addresses falling within the I/O base and limit address registers and within the first 64KB of PCI I/O space.</p> <p>When 0—The 21150 forwards all I/O transactions downstream that fall within the I/O base and limit address registers.</p> <p>When 1—The 21150 ignores primary bus I/O transactions within the I/O base and limit address registers and within the first 64KB of PCI I/O space that address the last 768 bytes in each 1KB block. Secondary bus I/O transactions are forwarded upstream if the address falls within the last 768 bytes in each 1KB block.</p> <p>Reset value: 0.</p>
19	VGA enable	R/W	<p>Modifies the 21150's response to VGA-compatible addresses.</p> <p>When 0—VGA transactions are ignored on the primary bus unless they fall within the I/O base and limit address registers and the ISA mode is 0.</p> <p>When 1—The 21150 positively decodes and forwards the following transactions downstream, regardless of the values of the I/O base and limit registers, ISA mode bit, or VGA snoop bit:</p> <ul style="list-style-type: none"> • Memory transactions addressing 000A0000h–000BFFFFh • I/O transactions addressing: <ul style="list-style-type: none"> — p_ad<9:0> = 3B0h–3BBh and 3C0h–3DFh — p_ad<15:10> are not decoded. — p_ad<31:16> = 0000h. <p>I/O and memory space enable bits must be set in the command register.</p> <p>The transactions listed here are ignored by the 21150 on the secondary bus.</p> <p>Reset value: 0.</p>
20	Reserved	R	Reserved. Returns 0 when read.

Dword Bit	Name	R/W	Description
21	Master abort mode	R/W	<p>Controls the 21150's behavior when a master abort termination occurs in response to a transaction initiated by the 21150 on either the primary or secondary PCI interface.</p> <p>When 0—The 21150 asserts TRDY# on the initiator bus for delayed transactions, and FFFF FFFFh for read transactions. For posted write transactions, p_serr_l is not asserted.</p> <p>When 1—The 21150 returns a target abort on the initiator bus for delayed transactions. For posted write transactions, the 21150 asserts p_serr_l if the SERR# enable bit is set in the command register.</p> <p>Reset value: 0.</p>
22	Secondary bus reset	R/W	<p>Controls s_rst_l on the secondary interface.</p> <p>When 0—The 21150 deasserts s_rst_l.</p> <p>When 1—The 21150 asserts s_rst_l. When s_rst_l is asserted, the data buffers and the secondary interface are initialized back to reset conditions. The primary interface and configuration registers are not affected by the assertion of s_rst_l.</p> <p>Reset value: 0.</p>
23	Fast back-to-back enable		<p>Controls the ability of the 21150 to generate fast back-to-back transactions on the secondary interface.</p> <p>When 0—The 21150 does not generate fast back-to-back transactions on the secondary PCI bus.</p> <p>When 1—The 21150 is enabled to generate fast back-to-back transactions on the secondary PCI bus.</p> <p>Reset value: 0.</p>
24	Primary master timeout	R/W	<p>Sets the maximum number of PCI clock cycles that the 21150 waits for an initiator on the primary bus to repeat a delayed transaction request. The counter starts once the delayed transaction completion is at the head of the queue. If the master has not repeated the transaction at least once before the counter expires, the 21150 discards the transaction from its queues.</p> <p>When 0—The primary master timeout value is 2^{15} PCI clock cycles, or 0.983 ms for a 33-MHz bus.</p> <p>When 1—The value is 2^{10} PCI clock cycles, or 30.7 μs for a 33-MHz bus.</p> <p>Reset value: 0.</p>

Dword Bit	Name	R/W	Description
25	Secondary master timeout	R/W	<p>Sets the maximum number of PCI clock cycles that the 21150 waits for an initiator on the secondary bus to repeat a delayed transaction request. The counter starts once the delayed transaction completion is at the head of the queue. If the master has not repeated the transaction at least once before the counter expires, the 21150 discards the transaction from its queues.</p> <p>When 0—The primary master timeout value is 2^{15} PCI clock cycles, or 0.983 ms for a 33-MHz bus.</p> <p>When 1—The value is 2^{10} PCI clock cycles, or 30.7 μs for a 33-MHz bus.</p> <p>Reset value: 0.</p>
26	Master timeout status	R/W1TC	<p>This bit is set to 1 when either the primary master timeout counter or the secondary master timeout counter expires and a delayed transaction is discarded from the 21150's queues. Write 1 to clear.</p> <p>Reset value: 0.</p>
27	Master timeout SERR# enable	R/W	<p>Controls assertion of p_serr_ during a master timeout.</p> <p>When 0—Signal p_serr_ is not asserted as a result of a master timeout.</p> <p>When 1—Signal p_serr_ is asserted when either the primary master timeout counter or the secondary master timeout counter expires and a delayed transaction is discarded from the 21150's queues. The SERR# enable bit in the command register must also be set.</p> <p>Reset value: 0.</p>
31:28	Reserved	R	Reserved. Returns 0 when read.

15.1.32 Capability ID Register—Offset DCh

This section describes the capability ID register. (Implemented in the 21150-AB and later revisions only. In the 21150-AA, these registers are reserved.)

Dword address = DCh

Byte enable p_cbe_<3:0> = xxx0b

Dword Bit	Name	R/W	Description
7:0	CAP_ID	R/W	Enhanced capabilities ID. Reads only as 01h to indicate that these are power management enhanced capability registers.

15.1.33 Next Item Ptr Register—Offset DDh

This section describes the next item ptr register. (Implemented in the 21150-AB and later revisions only. In the 21150-AA, these registers are reserved.)

Dword address = DCh

Byte enable p_cbe_l<3:0> = xx0xb

Dword Bit	Name	R/W	Description
15:8	NEXT_ITEM	R	Next item pointer. Reads as 0 to indicate that there are no other ECP registers.

15.1.34 Power Management Capabilities Register—Offset DEh

This section describes the power management capabilities register. (Implemented in the 21150-AB and later revisions only. In the 21150-AA, these registers are reserved.)

Dword address = DCh

Byte enable p_cbe_l<3:0> = 00xxb

Dword Bit	Name	R/W	Description
18:16	PM_VER	R	Power Management Revision. Reads as 001 to indicate that this device is compliant with Revision 1.0 of the <i>PCI Power Management Interface Specification</i> .
19	PME#Clock	R	PME# Clock Required. Reads as 0 to indicate that this device does not support the PME# pin.
20	AUX	R	Auxiliary Power Support. Reads as 0 to indicate that this device does not have PME# support or an auxiliary power source.
21	DSI	R	Device Specific Initialization. Reads as 0 to indicate that this device does not have device-specific initialization requirements.
24:22	Reserved	R	Reserved. Read as 000b.
25	D1	R	D1 Power State Support. Reads as 0 to indicate that this device does not support the D1 power management state.
26	D2	R	D2 Power State Support. Reads as 0 to indicate that this device does not support the D2 power management state.
31:27	PME_SUP	R	PME# Support. Reads as 0 to indicate that this device does not support the PME# pin.

15.1.35 Power Management Control and Status Register—Offset E0h

This section describes the power management control and status register. (Implemented in the 21150-AB and later revisions only. In the 21150-AA, these registers are reserved.)

Dword address = E0h

Byte enable p_cbe_l<3:0> = xx00b

Dword Bit	Name	R/W	Description
1:0	PWR_STATE	R	Power State. Reflects the current power state of this device. If an unimplemented power state is written to this register, the 21150 completes the write transaction, ignores the write data, and does not change the value of this field. Writing a value of D0 when the previous state was D3 causes a chip reset to occur (without asserting s_rst_l). <ul style="list-style-type: none"> • 00b: D0 • 01b: D1 (not implemented) • 10b: D2 (not implemented) • 11b: D3 Reset value: 00b.
7:2	Reserved	R	Reserved. Reads as 000000b.
8	PME_EN	R	PME# Enable. Reads as 0 because the PME# pin is not implemented.
12:9	DATA_SEL	R	Data Select. Reads as 0000b because the data register is not implemented.
14:13	DATA_SCALE		Data Scale. Reads as 00b because the data register is not implemented.
15	PME_STAT	R	PME Status. Reads as 0 because the PME# pin is not implemented.

15.1.36 PPB Support Extensions Registers—Offset E2h

This section describes the PPB support extensions registers. (Implemented in the 21150-AB and later revisions only. In the 21150-AA, these registers are reserved.)

Dword address = E0h

Byte enable p_cbe_l<3:0> = x0xxb

Dword Bit	Name	R/W	Description
21:16	Reserved	R	Reserved. Read only as 000000b.
22	B2_B3	R	B2_B3 Support for D3 _{hot} . When the BPCC_En bit (bit 23) reads as 1, this bit reads as 1 to indicate that the secondary bus clock outputs will be stopped and driven low when this device is placed in D3 _{hot} . This bit is not defined when the BPCC_En bit reads as 0.

Dword Bit	Name	R/W	Description
23	BPCC_EN	R	Bus Power/Clock Control Enable. When the bpcce pin is tied high, this bit reads as a 1 to indicate that the bus power/clock control mechanism is enabled, as described in B2_B3 (bit 22). When the bpcce pin is tied low, this bit reads as a 0 to indicate that the bus power/clock control mechanism is disabled (secondary clocks are not disabled when this device is placed in D3 _{hot} .)

15.1.37 Data Register—Offset E3h

This section describes the data register.

Dword address = E0h

Byte enable p_cbe_l<3:0> = 0xxxb

Dword Bit	Name	R/W	Description
31:24	Data	R	Data register. This register is not implemented and reads 00h.

15.2 Device-Specific Configuration Registers

This section provides a detailed description of the 21150 device-specific configuration registers.

Each field has a separate description.

Fields that have the same configuration address are selectable by turning on (driving low) the appropriate byte enable bits on p_cbe_l during the data phase. To select all fields of a configuration address, drive all byte enable bits low.

All reserved fields and registers are read only and always return 0.

15.2.1 Chip Control Register—Offset 40h

This section describes the chip control register.

Dword address = 40h

Byte enable p_cbe_l<3:0> = xxx0b

Dword Bit	Name	R/W	Description
0	Reserved	R	Reserved. Returns 0 when read.
1	Memory write disconnect control	R/W	Controls when the 21150, as a target, disconnects memory write transactions. When 0—The 21150 disconnects on queue full or on a 4KB boundary. When 1—The 21150 disconnects on a cache line boundary, as well as when the queue fills or on a 4KB boundary. Reset value: 0.
3:2	Reserved	R	Reserved. Returns 0 when read.
4	Secondary bus prefetch disable	R/W	Controls the 21150's ability to prefetch during upstream memory read transactions. When 0—The 21150 prefetches and does not forward byte enable bits during memory read transactions. When 1—The 21150 requests only one Dword from the target during memory read transactions and forwards read byte enable bits. The 21150 returns a target disconnect to the requesting master on the first data transfer. Memory read line and memory read multiple transactions are still prefetchable. Reset value: 0.
5	Live insertion mode	R/W	Enables hardware control of transaction forwarding in the 21150. When 0—Pin gpio<3> has no effect on the I/O, memory, and master enable bits. When 1—If the output enable control for gpio<3> is set to input only in the gpio output enable control register, this bit enables gpio<3> to mask the I/O enable, memory enable, and master enable bits to 0. These enable bits are masked when gpio<3> is driven high. When this occurs, the 21150 stops accepting I/O and memory transactions. Reset value: 0.
7:6	Reserved	R	Reserved. Returns 0 when read.

15.2.2 Diagnostic Control Register—Offset 41h

This section describes the diagnostic control register.

WITR indicates that writing 1 in this bit position causes a chip reset to occur. Writing 0 has no effect.

Dword address = 40h

Byte enable p_cbe_l<3:0> = xx0xb

Dword Bit	Name	R/W	Description
8	Chip reset	R/W1TR	<p>Chip and secondary bus reset control.</p> <p>When 1—Causes the 21150 to perform a chip reset. Data buffers, configuration registers, and both the primary and secondary interfaces are reset to their initial state.</p> <p>The 21150 clears this bit once chip reset is complete. The 21150 can then be reconfigured.</p> <p>Secondary bus reset s_rst_l is asserted and the secondary reset bit in the bridge control register is set when this bit is set. The secondary reset bit in the bridge control register must be cleared in order to deassert s_rst_l.</p>
10:9	Test mode	R/W	<p>Controls the testability of the 21150's internal counters. These bits are used for chip test only. The value of these bits controls which bytes of the counters are exercised:</p> <ul style="list-style-type: none"> • 00b = Normal functionality—all bits are exercised. • 01b = Byte 1 is exercised. • 10b = Byte 2 is exercised. • 11b = Byte 0 is exercised. <p>Reset value: 00b.</p>
15:11	Reserved	R	Reserved. Returns 0 when read.

15.2.3 Arbiter Control Register—Offset 42h

This section describes the arbiter control register.

Dword address = 40h

Byte enablep_cbe_l<3:0> = 00xxb

Dword Bit	Name	R/W	Description
25:16	Arbiter control	R/W	<p>Each bit controls whether a secondary bus master is assigned to the high priority arbiter group or the low priority arbiter group. Bits <24:16> correspond to request inputs s_req_l<8:0>, respectively. Bit <25> corresponds to the 21150 as a secondary bus master.</p> <p>When 0—Indicates that the master belongs to the low priority group.</p> <p>When 1—Indicates that the master belongs to the high priority group.</p> <p>Reset value: 10 0000 0000b.</p>
31:26	Reserved	R	Reserved. Returns 0 when read.

15.2.4 p_serr_l Event Disable Register—Offset 64h

This section describes the p_serr_l event disable register.

Dword address = 64h

Byte enable p_cbe_l<3:0> = xxx0b

Dword Bit	Name	R/W	Description
0	Reserved	R	Reserved. Returns 0 when read.
1	Posted write parity error	R/W	Controls the 21150's ability to assert p_serr_l when a data parity error is detected on the target bus during a posted write transaction. When 0—Signal p_serr_l is asserted if this event occurs and the SERR# enable bit in the command register is set. When 1—Signal p_serr_l is not asserted if this event occurs. Reset value: 0.
2	Posted write nondelivery	R/W	Controls the 21150's ability to assert p_serr_l when it is unable to deliver posted write data after 2 ²⁴ attempts. When 0—Signal p_serr_l is asserted if this event occurs and the SERR# enable bit in the command register is set. When 1—Signal p_serr_l is not asserted if this event occurs. Reset value: 0.
3	Target abort during posted write	R/W	Controls the 21150's ability to assert p_serr_l when it receives a target abort when attempting to deliver posted write data. When 0—Signal p_serr_l is asserted if this event occurs and the SERR# enable bit in the command register is set. When 1—Signal p_serr_l is not asserted if this event occurs. Reset value: 0.
4	Master abort on posted write	R/W	Controls the 21150's ability to assert p_serr_l when it receives a master abort when attempting to deliver posted write data. When 0—Signal p_serr_l is asserted if this event occurs and the SERR# enable bit in the command register is set. When 1—Signal p_serr_l is not asserted if this event occurs. Reset value: 0.

Dword Bit	Name	R/W	Description
5	Delayed write nondelivery	R/W	Controls the 21150's ability to assert p_serr_l when it is unable to deliver delayed write data after 2 ²⁴ attempts. When 0—Signal p_serr_l is asserted if this event occurs and the SERR# enable bit in the command register is set. When 1—Signal p_serr_l is not asserted if this event occurs. Reset value: 0.
6	Delayed read—no data from target	R/W	Controls the 21150's ability to assert p_serr_l when it is unable to transfer any read data from the target after 2 ²⁴ attempts. When 0—Signal p_serr_l is asserted if this event occurs and the SERR# enable bit in the command register is set. When 1—Signal p_serr_l is not asserted if this event occurs. Reset value: 0.
7	Reserved	R	Reserved. Returns 0 when read.

15.2.5 gpio Output Data Register—Offset 65h

This section describes the gpio output data register.

Dword address = 64h

Byte enable p_cbe_l<3:0> = xx0xb

Dword Bit	Name	R/W	Description
11:8	GPIO output write-1-to-clear	R/W1TC	The gpio<3:0> pin output data write-1-to-clear. Writing 1 to any of these bits drives the corresponding bit low on the gpio<3:0> bus if it is programmed as bidirectional. Data is driven on the PCI clock cycle following completion of the configuration write to this register. Bit positions corresponding to gpio pins that are programmed as input only are not driven. Writing 0 to these bits has no effect. When read, reflects the last value written. Reset value: 0.
15:12	GPIO output write-1-to-set	R/W1TC	The gpio<3:0> pin output data write-1-to-set. Writing 1 to any of these bits drives the corresponding bit high on the gpio<3:0> bus if it is programmed as bidirectional. Data is driven on the PCI clock cycle following completion of the configuration write to this register. Bit positions corresponding to gpio pins that are programmed as input only are not driven. Writing 0 to these bits has no effect. When read, reflects the last value written. Reset value: 0.

15.2.6 gpio Output Enable Control Register—Offset 66h

This section describes the gpio output enable control register.

Dword address = 64h

Byte enable p_cbe_l<3:0> = x0xxb

Dword Bit	Name	R/W	Description
19:16	GPIO output enable write-1-to-clear	R/W1TC	The gpio<3:0> output enable control write-1-to-clear. Writing 1 to any of these bits configures the corresponding gpio<3:0> pin as an input only; that is, the output driver is tristated. Writing 0 to this register has no effect. When read, reflects the last value written. Reset value: 0 (all pins are input only).
23:20	GPIO output enable write-1-to-set	R/W1TS	The gpio<3:0> output enable control write-1-to-set. Writing 1 to any of these bits configures the corresponding gpio<3:0> pin as bidirectional, that is, enables the output driver and drives the value set in the output data register (65h). Writing 0 to this register has no effect. When read, reflects the last value written. Reset value: 0 (all pins are input only).

15.2.7 gpio Input Data Register—Offset 67h

This section describes the gpio input data register.

Dword address = 64h

Byte enable p_cbe_l<3:0> = 0xxxb

Dword Bit	Name	R/W	Description
27:24	Reserved	R	Reserved. Returns 0 when read.
31:28	GPIO input	R	This read-only register reads the state of the gpio<3:0> pins. This state is updated on the PCI clock cycle following a change in the gpio pins.

15.2.8 Secondary Clock Control Register—Offset 68h

This section describes the secondary clock control register.

Dword address = 68h

Byte enable p_cbe_l<3:0> = xx00b

Dword Bit	Name	R/W	Description
1:0	Slot 0 clock disable	R/W	<p>If either bit is 0: Signal s_clk_o<0> is enabled. When both bits are 1—Signal s_clk_o<0> is disabled and driven low.</p> <p>Upon secondary bus reset, this bit is initialized by shifting in a serial data stream. These bits are assigned to correspond to the PRSNT# pins for slot 0.</p>
3:2	Slot 1 clock disable	R/W	<p>If either bit is 0—Signal s_clk_o<1> is enabled. When both bits are 1—Signal s_clk_o<1> is disabled and driven low.</p> <p>Upon secondary bus reset, this bit is initialized by shifting in a serial data stream. These bits are assigned to correspond to the PRSNT# pins for slot 1.</p>
5:4	Slot 2 clock disable	R/W	<p>If either bit is 0—Signal s_clk_o<2> is enabled. When both bits are 1—Signal s_clk_o<2> is disabled and driven low.</p> <p>Upon secondary bus reset, this bit is initialized by shifting in a serial data stream. These bits are assigned to correspond to the PRSNT# pins for slot 2.</p>
7:6	Slot 3 clock disable	R/W	<p>If either bit is 0—Signal s_clk_o<3> is enabled. When both bits are 1—Signal s_clk_o<3> is disabled and driven low.</p> <p>Upon secondary bus reset, this bit is initialized by shifting in a serial data stream. These bits are assigned to correspond to the PRSNT# pins for slot 3.</p>
8	Device 1 clock disable	R/W	<p>When 0—Signal s_clk_o<4> is enabled. When 1—Signal s_clk_o<4> is disabled and driven low.</p> <p>Upon secondary bus reset, this bit is initialized by shifting in a serial data stream.</p>
9	Device 2 clock disable	R/W	<p>When 0—Signal s_clk_o<5> is enabled. When 1—Signal s_clk_o<5> is disabled and driven low.</p> <p>Upon secondary bus reset, this bit is initialized by shifting in a serial data stream.</p>
10	Device 3 clock disable	R/W	<p>When 0—Signal s_clk_o<6> is enabled. When 1—Signal s_clk_o<6> is disabled and driven low.</p> <p>Upon secondary bus reset, this bit is initialized by shifting in a serial data stream.</p>
11	Device 4 clock disable	R/W	<p>When 0—Signal s_clk_o<7> is enabled. When 1—Signal s_clk_o<7> is disabled and driven low.</p> <p>Upon secondary bus reset, this bit is initialized by shifting in a serial data stream.</p>
12	Device 5 clock disable	R/W	<p>When 0—Signal s_clk_o<8> is enabled. When 1—Signal s_clk_o<8> is disabled and driven low.</p> <p>Upon secondary bus reset, this bit is initialized by shifting in a serial data stream.</p>

Dword Bit	Name	R/W	Description
13	The 21150 clock disable	R/W	When 1—Signal s_clk_o<9> is disabled and driven low. When 0—Signal s_clk_o<9> is enabled. Upon secondary bus reset, this bit is initialized by shifting in a serial data stream. This bit is assigned to correspond to the 21150 secondary clock input, s_clk.
15:14	Reserved	R	Reserved. Returns 0 when read.

15.2.9 p_serr_l Status Register—Offset 6Ah

This section describes the p_serr_l status register.

This status register indicates the reason for the 21150's assertion of p_serr_l.

Dword address = 68h

Byte enable p_cbe_l<3:0> = x0xxb

Dword Bit	Name	R/W	Description
16	Address parity error	R/W1TC	When 1—Signal p_serr_l was asserted because an address parity error was detected on either the primary or secondary PCI bus. Reset value: 0.
17	Posted write data parity error	R/W1TC	When 1—Signal p_serr_l was asserted because a posted write data parity error was detected on the target bus. Reset value: 0.
18	Posted write nondelivery	R/W1TC	When 1—Signal p_serr_l was asserted because the 21150 was unable to deliver posted write data to the target after 2 ²⁴ attempts. Reset value: 0.
19	Target abort during posted write	R/W1TC	When 1—Signal p_serr_l was asserted because the 21150 received a target abort when delivering posted write data. Reset value: 0.
20	Master abort during posted write	R/W1TC	When 1—Signal p_serr_l was asserted because the 21150 received a master abort when attempting to deliver posted write data. Reset value: 0.

Dword Bit	Name	R/W	Description
21	Delayed write nondelivery	R/W1TC	When 1—Signal p_serr_l was asserted because the 21150 was unable to deliver delayed write data after 2 ²⁴ attempts. Reset value: 0.
22	Delayed read—no data from target	R/W1TC	When 1—Signal p_serr_l was asserted because the 21150 was unable to read any data from the target after 2 ²⁴ attempts. Reset value: 0.
23	Delayed transaction master timeout	R/W1TC	When 1—Signal p_serr_l was asserted because a master did not repeat a read or write transaction before the master timeout counter expired on the initiator's PCI bus. Reset to 0.

15.3 Configuration Register Values After Reset

Table 35 lists the value of the 21150 configuration registers after reset. Reserved registers are not listed and are always read as 0.

Table 35. Configuration Register Values After Reset (Sheet 1 of 2)

Byte Address	Register Name	Reset Value
00–01h	Vendor ID	1011h
02–03h	Device ID	0022h
04–05h	Command	0000h
06–07h	Status	0280h–21150-AA only 0290h–33 MHz 21150 02B0h–66 MHz capable 21150
8h	Revision ID	xxh ¹
09–0Bh	Class code	060400h
0Ch	Cache line	00h
0Dh	Primary master latency timer	00h
0Eh	Header type	01h
18h	Primary bus number	00h
19h	Secondary bus number	00h
1Ah	Subordinate bus number	00h
1Bh	Secondary master latency timer	00h
1Ch	I/O base	01h
1Dh	I/O limit	01h
1Eh–1Fh	Secondary status	0280h–33 MHz 21150 02A0h–66 MHz capable 21150
20–21h	Memory mapped I/O base	0000h
22–23h	Memory-mapped I/O limit	0000h
24–25h	Prefetchable memory base	0001h

Table 35. Configuration Register Values After Reset (Sheet 2 of 2)

Byte Address	Register Name	Reset Value
26–27h	Prefetchable memory limit	0001h
28–2Bh	Prefetchable memory base upper 32 bits	00000000h
2C–2Fh	Prefetchable memory limit upper 32 bits	00000000h
30–31h	I/O base upper 16 bits	0000h
32–33h	I/O limit upper 16 bits	0000h
34–35h	Subsystem vendor ID–21150-AA only ECP pointer	0000h 00DCh
36–37h	Subsystem ID–21150-AA only Reserved	0000h
3Dh	Interrupt pin	00h
3E–3Fh	Bridge control	0000h
40h	Chip control	00h
41h	Diagnostic control	00h
42–43h	Arbiter control	0200h
64h	p_serr_l event disable	00h
65h	gpio output data	00h
66h	gpio output enable control	00h
67h	gpio input data	00h
68–69h	Secondary clock control ²	
6Ah	p_serr_l status	00h
DCh	Power management capability ID ³	01h
DDh	Next item pointer ³	00h
DE–DFh	Power management capabilities register ³	01h
E0–E1h	Power management control and status ³	00h
E2h	PPB support extensions ³	00h (bpcce = 0) C0h (bpcce = 1)
E3h	Power management data register ³	00h

1. Dependent on revision of device.

2. The value of this register is dependent upon the serial clock disable shift function that occurs during secondary bus reset.

3. Reserved in the 21150-AA.

16.0 JTAG Test Port

This chapter describes the 21150's implementation of a joint test action group (JTAG) test port according to IEEE Standard 1149.1, *IEEE Standard Test Access Port and Boundary-Scan Architecture*.

16.1 Overview

The 21150 contains a serial-scan test port that conforms to IEEE standard 1149.1. The JTAG test port consists of the following:

- A 5-wire test access port
- A test access port controller
- An instruction register
- A bypass register
- A boundary-scan register

Note: The JTAG test access port is to be used only while the 21150 is not operating.

16.2 JTAG Signal Pins

This chapter describes the JTAG pins listed in [Table 36](#).

Table 36. JTAG Pins

Signal Name	Type	Description
tdi	Input	Serial boundary-scan data in
tdo	Output	Serial boundary-scan data out
tms	Input	JTAG test mode select
tck	Input	Boundary-scan clock
trst_l	Input	JTAG test access port reset

16.3 Test Access Port Controller

The test access port controller is a finite state machine that interprets IEEE 1149.1 protocols received through the tms line.

The state transitions in the controller are caused by the tms signal on the rising edge of tck. In each state, the controller generates appropriate clock and control signals that control the operation of the test features. After entry into a state, test feature operations are initiated on the rising edge of tck.

16.4 Instruction Register

The 5-bit instruction register selects the test modes and features. The instruction register bits are interpreted as instructions, as shown in Table 37. The instructions select and control the operation of the boundary-scan and bypass registers.

Table 37 describes the 21150's instructions.

Table 37. JTAG Instruction Registers

Instruction Register Contents	Instruction Name (Test Mode or State)	Test Register Selected	Operation
00000	EXTEST	Boundary-scan	External test (drives pins from the boundary-scan register)
00001	SAMPLE	Boundary-scan	Samples I/O
00010	BSROSC	Boundary-scan	Ring oscillates the boundary-scan register
00011	BSRDLY	Boundary-scan	Configures the boundary-scan register for propagation delay measurement
00100	CLAMP	Bypass	Drives pins from the boundary-scan register and selects the bypass register for shifts
00101	HIGHZ	Bypass	Tristates all output and I/O pins except the tdo pin
00110--11111	BYPASS	Bypass	Selects the bypass register for shifts

The instruction register is loaded through the tdi pin. The instruction register has a shift-in stage from which the instruction is then loaded in parallel.

16.5 Bypass Register

The bypass register is a 1-bit shift register that provides a means for effectively bypassing the JTAG test logic through a single-bit serial connection through the chip from tdi to tdo. At board-level testing, this helps reduce overall length of the scan ring.

16.6 Boundary-Scan Register

The boundary-scan register is a single-shift register-based path formed by boundary-scan cells placed at the chip's signal pins. The register is accessed through the JTAG port's tdi and tdo pins.

16.6.1 Boundary-Scan Register Cells

Each boundary-scan cell operates in conjunction with the current instruction and the current state in the test access port controller state machine. The function of the BSR cells is determined by the associated pins, as follows:

- Input-only pins—The boundary-scan cell is basically a 1-bit shift register. The cell supports sample and shift functions.
- Output-only pins—The boundary-scan cell comprises a 1-bit shift register and an output multiplexer. The cell supports the sample, shift, and drive output functions.
- Bidirectional pins—The boundary-scan cell is identical to the output-only pin cell, but it captures test data from the incoming data line. The cell supports sample, shift, drive output, and hold output functions. It is used at all I/O pins.

16.6.2 21150 Boundary-Scan Order

Table 38 lists the boundary-scan register order and the group disable controls. The group disable control either enables or tristates its corresponding group of bidirectional drivers. When the value of a group disable control bit is 0, the output driver is enabled. When the value is 1, the driver is tristated. There are nine groups of bidirectional drivers, and therefore nine group disable control bits.

The Group Disable Number column in Table 38 shows which group disable bit controls the corresponding output driver. Group disable bits do not affect input-only pins, so those pins have a blank rather than a group number in the Group Disable Number column. The group disable control wire can control pins on either side of where the group disable boundary-scan register is placed. The group disable boundary-scan registers have a boundary-scan register number entry, but they do not have a corresponding pin number or signal name.

Data shifts from tdi into the most significant bit of the boundary-scan register, and from the least significant bit of the boundary-scan register out to tdo.

Table 38. Boundary-Scan Order (Sheet 1 of 5)

Pin Number	Signal Name	Boundary-Scan Register Number	Group Disable Number	Group Disable Cell
2	s_req_l<1>	50	—	—
3	s_req_l<2>	51	—	—
4	s_req_l<3>	52	—	—
5	s_req_l<4>	53	—	—
6	s_req_l<5>	54	—	—
7	s_req_l<6>	55	—	—
8	s_req_l<7>	56	—	—
9	s_req_l<8>	57	—	—
10	s_gnt_l<0>	58	5	—
11	s_gnt_l<1>	59	5	—
		60	—	5
13	s_gnt_l<2>	61	5	—
14	s_gnt_l<3>	62	5	—

Table 38. Boundary-Scan Order (Sheet 2 of 5)

Pin Number	Signal Name	Boundary-Scan Register Number	Group Disable Number	Group Disable Cell
15	s_gnt_l<4>	63	5	—
16	s_gnt_l<5>	64	5	—
17	s_gnt_l<6>	65	5	—
18	s_gnt_l<7>	66	5	—
19	s_gnt_l<8>	67	5	—
21	s_clk	68	—	—
22	s_rst_l	69	4	—
23	s_cfn_l	70	—	—
24	gpio<3>	71	4	—
25	gpio<2>	72	4	—
27	gpio<1>	73	4	—
28	gpio<0>	74	4	—
29	s_clk_o<0>	75	4	—
30	s_clk_o<1>	76	4	—
		77	—	4
32	s_clk_o<2>	78	4	—
33	s_clk_o<3>	79	4	—
35	s_clk_o<4>	80	4	—
36	s_clk_o<5>	81	4	—
38	s_clk_o<6>	82	4	—
39	s_clk_o<7>	83	4	—
41	s_clk_o<8>	84	4	—
42	s_clk_o<9>	85	4	—
43	p_rst_l	86	—	—
45	p_clk	87	—	—
46	p_gnt_l	88	—	—
47	p_req_l	89	3	—
		90	—	3
49	p_ad<31>	91	2	—
50	p_ad<30>	92	2	—
55	p_ad<29>	93	2	—
57	p_ad<28>	94	2	—
58	p_ad<27>	95	2	—
60	p_ad<26>	96	2	—
61	p_ad<25>	97	2	—
63	p_ad<24>	98	2	—
64	p_cbe_l<3>	99	2	—

Table 38. Boundary-Scan Order (Sheet 3 of 5)

Pin Number	Signal Name	Boundary-Scan Register Number	Group Disable Number	Group Disable Cell
65	p_isdel	100	—	—
67	p_ad<23>	101	2	—
68	p_ad<22>	102	2	—
70	p_ad<21>	103	2	—
71	p_ad<20>	104	2	—
73	p_ad<19>	105	2	—
74	p_ad<18>	106	2	—
76	p_ad<17>	107	2	—
77	p_ad<16>	108	2	—
		109	—	2
79	p_cbe_l<2>	110	2	—
80	p_frame_l	111	1	—
82	p_irdy_l	112	1	—
83	p_trdy_l	113	1	—
84	p_devsel_l	114	1	—
85	p_stop_l	115	1	—
		116	—	1
87	p_lock_l	117	—	—
88	p_perr_l	118	1	—
89	p_serr_l	119	1	—
90	p_par	120	0	—
92	p_cbe_l<1>	121	0	—
93	p_ad<15>	122	0	—
95	p_ad<14>	123	0	—
96	p_ad<13>	124	0	—
98	p_ad<12>	125	0	—
99	p_ad<11>	126	0	—
101	p_ad<10>	127	0	—
102	p_m66ena	128	—	—
107	p_ad<9>	129	0	—
109	p_ad<8>	130	0	—
110	p_cbe_l<0>	131	0	—
112	p_ad<7>	132	0	—
113	p_ad<6>	133	0	—
115	p_ad<5>	134	0	—
116	p_ad<4>	135	0	—
118	p_ad<3>	136	0	—

Table 38. Boundary-Scan Order (Sheet 4 of 5)

Pin Number	Signal Name	Boundary-Scan Register Number	Group Disable Number	Group Disable Cell
119	p_ad<2>	137	0	—
121	p_ad<1>	138	0	—
122	p_ad<0>	139	0	—
		140	—	0
125	config66	141	—	—
126	msk_in	142	—	—
	tdi	—	—	—
	tdo	—	—	—
137	s_ad<0>	0	8	—
138	s_ad<1>	1	8	—
140	s_ad<2>	2	8	—
141	s_ad<3>	3	8	—
143	s_ad<4>	4	8	—
144	s_ad<5>	5	8	—
146	s_ad<6>	6	8	—
147	s_ad<7>	7	8	—
149	s_cbe_l<0>	8	8	—
150	s_ad<8>	9	8	—
152	s_ad<9>	10	8	—
153	s_m66ena	11	8	—
154	s_ad<10>	12	8	—
159	s_ad<11>	13	8	—
161	s_ad<12>	14	8	—
162	s_ad<13>	15	8	—
164	s_ad<14>	16	8	—
165	s_ad<15>	17	8	—
		18	—	8
167	s_cbe_l<1>	19	8	—
168	s_parr	20	8	—
169	s_serr_l	21	—	—
171	s_perr_l	22	7	—
172	s_lock_l	23	7	—
173	s_stop_l	24	7	—
		25	—	7
175	s_devsel_l	26	7	—
176	s_trdy_l	27	7	—
177	s_iridy_l	28	7	—

Table 38. Boundary-Scan Order (Sheet 5 of 5)

Pin Number	Signal Name	Boundary-Scan Register Number	Group Disable Number	Group Disable Cell
179	s_frame_l	29	7	—
180	s_cbe_l<2>	30	6	—
182	s_ad<16>	31	6	—
183	s_ad<17>	32	6	—
185	s_ad<18>	33	6	—
186	s_ad<19>	34	6	—
188	s_ad<20>	35	6	—
189	s_ad<21>	36	6	—
191	s_ad<22>	37	6	—
192	s_ad<23>	38	6	—
194	s_cbe_l<3>	39	6	—
195	s_ad<24>	40	6	—
197	s_ad<25>	41	6	—
198	s_ad<26>	42	6	—
200	s_ad<27>	43	6	—
201	s_ad<28>	44	6	—
203	s_ad<29>	45	6	—
204	s_ad<30>	46	6	—
		47	—	6
206	s_ad<31>	48	6	—
207	s_req_l<0>	49	—	—

16.7 Initialization

The test access port controller and the instruction register output latches are initialized when the `trst_l` input is asserted. The test access port controller enters the test-logic reset state. The instruction register is reset to hold the bypass register instruction. During test-logic reset state, all JTAG test logic is disabled, and the chip performs normal functions. The test access port controller leaves this state only when an appropriate JTAG test operation sequence is sent on the `tms` and `tck` pins.

17.0 Electrical Specifications

This chapter specifies the following electrical behavior of the 21150:

- PCI electrical conformance
- Absolute maximum ratings
- dc specifications
- ac timing specifications

17.1 PCI Electrical Specification Conformance

The 21150 PCI pins conform to the basic set of PCI electrical specifications in the *PCI Local Bus Specification, Revision 2.1*. See that document for a complete description of the PCI I/O protocol and pin ac specifications.

17.2 Absolute Maximum Ratings

The 21150 is specified to operate at a maximum frequency of 33 MHz, or 66 MHz if 66 MHz capable, at a junction temperature (T_j) not to exceed 125 °C. [Table 39](#) lists the absolute maximum ratings for the 21150. These are stress ratings only; stressing the device beyond the absolute maximum ratings may cause permanent damage. Operating beyond the functional operating range (see [Table 40](#)) is not recommended and extended exposure beyond the functional operating range may affect reliability.

Table 39. Absolute Maximum Ratings

Parameter	Minimum	Maximum
Junction temperature, T_j	—	125°C
Maximum voltage applied to signal pins	—	5.5 V
Supply voltage, V_{cc}	—	3.9 V
Maximum power, P_{wc} (33 MHz)	—	1.0 W @ 33 MHz
Maximum power, P_{wc} (66 MHz)	—	1.6 W @ 66MHz
Storage temperature range, T_{stg}	-55°C	+125°C

Table 40. Functional Operating Range

Parameter	Minimum	Maximum
Supply voltage, V_{cc}	3.0 V	3.6 V
Operating ambient temperature, T_a	0°C	70°C

17.3 DC Specifications

Table 41 defines the dc parameters met by all 21150 signals under the conditions of the functional operating range.

Table 41. DC Parameters

Symbol	Parameter	Condition	Minimum	Maximum	Unit
V_{cc}	Supply voltage	—	3.0	3.6	V
V_{il}	Low-level input voltage ¹	—	-0.5	$0.3 V_{cc}$	V
V_{ih}	High-level input voltage ¹	—	$0.5 V_{cc}$	$V_{cc} + 0.5 V$	V
V_{ol}	Low-level output voltage ²	$I_{out} = 1500 \mu A$	—	$0.1 V_{cc}$	V
V_{ol5V}	Low-level output voltage ³	$I_{out} = 6 mA$	—	0.55	V
V_{oh}	High-level output voltage ²	$I_{out} = -500 \mu A$	$0.9 V_{cc}$	—	V
V_{oh5V}	High-level output voltage ³	$I_{out} = -2 mA$	2.4	—	V
I_{il}	Low-level input leakage current ^{1, 4}	$0 < V_{in} < V_{cc}$	—	± 10	μA
C_{in}	Input pin capacitance	—	—	10.0	pF
C_{IDSEL}	p_idsel pin capacitance	—	—	8.0	pF
C_{clk}	p_clk, s_clk pin capacitance	—	5.0	12.0	pF

¹ Guarantees meeting the specification for the 5-V signaling environment.

² For 3.3-V signaling environment.

³ For 5-V signaling environment.

⁴ Input leakage currents include high-Z output leakage for all bidirectional buffers with tristate outputs.

Note: In Table 41, currents into the chip (chip sinking) are denoted as positive (+) current. Currents from the chip (chip sourcing) are denoted as negative (-) current.

17.4 AC Timing Specifications

The next sections specify the following:

- Clock timing specifications
- PCI signal timing specifications
- Reset timing specifications
- gpio timing specifications
- JTAG timing specifications

17.4.1 Clock Timing Specifications

The ac specifications consist of input requirements and output responses. The input requirements consist of setup and hold times, pulse widths, and high and low times. Output responses are delays from clock to signal. The ac specifications are defined separately for each clock domain within the 21150.

Figure 23 shows the ac parameter measurements for the p_clk and s_clk signals. Table 42 and Table 43 specify p_clk and s_clk parameter values for clock signal ac timing. See also Figure 24 for a further illustration of signal timing. Unless otherwise noted, all ac parameters are guaranteed when tested within the functional operating range of Table 40.

Figure 23. PCI Clock Signal AC Parameter Measurements

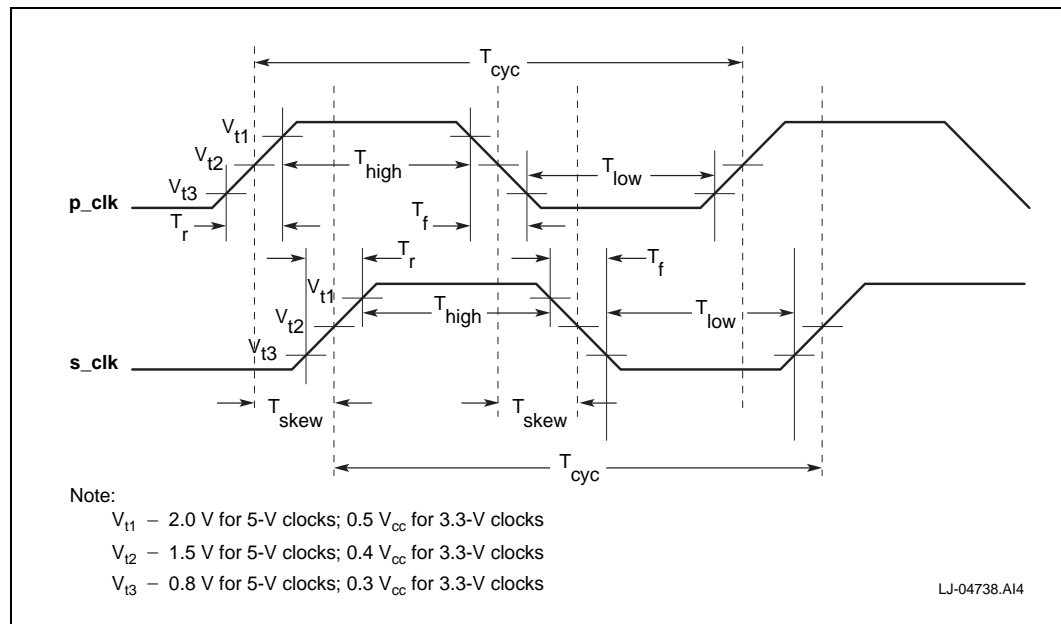

Table 42. 33 MHz PCI Clock Signal AC Parameters (Sheet 1 of 2)

Symbol	Parameter	Minimum	Maximum	Unit
T_{cyc}	p_clk, s_clk cycle time	30	∞	ns
T_{high}	p_clk, s_clk high time	11	—	ns
T_{low}	p_clk, s_clk low time	11	—	ns
	p_clk, s_clk slew rate ¹	1	4	V/ns
T_{sclk}	Delay from p_clk to s_clk	0	10	ns
T_{sclkr}	p_clk rising to s_clk_o rising	0	5	ns

Table 42. 33 MHz PCI Clock Signal AC Parameters (Sheet 2 of 2)

Symbol	Parameter	Minimum	Maximum	Unit
T_{sckf}	p_clk falling to s_clk_o falling ²	0	5	ns
T_{dskew}	s_clk_0 duty cycle skew from p_clk duty cycle	—	0.750	ns
T_{skew}	s_clk_0<x> to s_clk_0<y>	—	0.500	ns

¹. 0.2 V_{cc} to 0.6 V_{cc}

². Measured with 30-pF lumped load

Table 43. 66 MHz PCI Clock Signal AC Parameters

Symbol	Parameter	Minimum	Maximum	Unit
T_{cyc}	p_clk, s_clk cycle time	15	30	ns
T_{high}	p_clk, s_clk high time	6	—	ns
T_{low}	p_clk, s_clk low time	6	—	ns
	p_clk, s_clk slew rate ¹	1.5	4	V/ns
T_{sclk}	Delay from p_clk to s_clk	0	tbd ²	ns
T_{sclkr}	p_clk rising to s_clk_o rising	0	tbd	ns
T_{sckf}	p_clk falling to s_clk_o falling ³	0	tbd	ns
T_{dskew}	s_clk_0 duty cycle skew from p_clk duty cycle	—	0.750	ns
T_{skew}	s_clk_0<x> to s_clk_0<y>	—	0.500	ns

¹. 0.2 V_{cc} to 0.6 V_{cc}

². To be determined

³. Measured with 30-pF lumped load

17.4.2 PCI Signal Timing Specifications

Figure 24, Table 44, and Table 45 show the PCI signal timing specifications.

Figure 24. PCI Signal Timing Measurement Conditions

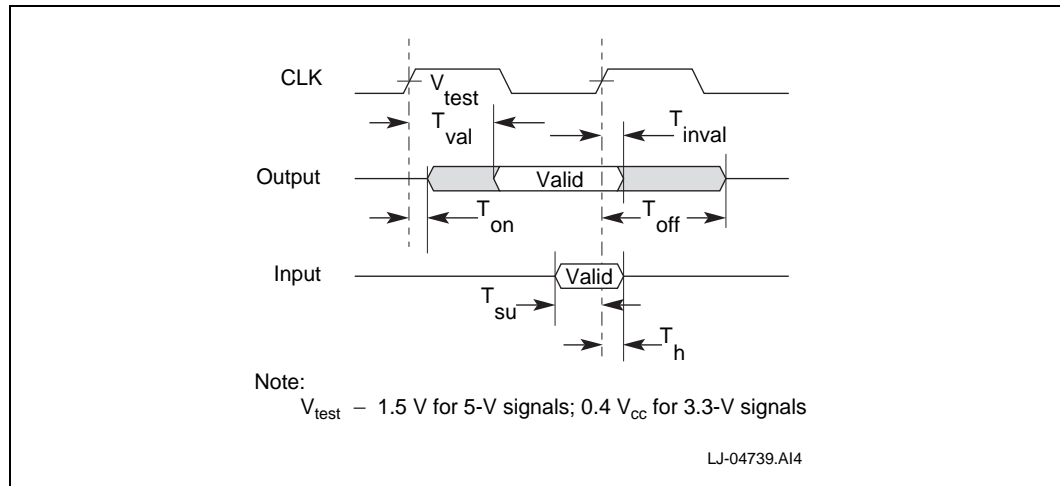

Table 44. 33 MHz PCI Signal Timing

Symbol	Parameter	Minimum	Maximum	Unit
T_{val}	CLK to signal valid delay—bused signals ^{1,2,3}	2	11	ns
$T_{val(ptp)}$	CLK to signal valid delay—point-to-point ^{1,2,3}	2	12	ns
T_{on}	Float to active delay ^{1,2,3}	2	—	ns
T_{off}	Active to float delay ^{1,2}	—	28	ns
T_{su}	Input setup time—bused signals ^{1,2,3}	7	—	ns
$T_{su(ptp)}$	Input setup time to CLK—point-to-point ^{1,2,3}	10, 12	—	ns
T_h	Input signal hold time from CLK ^{1,2}	0	—	ns

1. See Figure 23.
 2. All primary interface signals are synchronized to p_clk. All secondary interface signals are synchronized to s_clk.
 3. Point-to-point signals are p_req_l, s_req_l<8:0>, p_gnt_l, and s_gnt_l<8:0>. Bused signals are p_ad, p_cbe_l, p_par, p_perr_l, p_serr_l, p_frame_l, p_irdy_l, p_trdy_l, p_lock_l, p_devsel_l, p_stop_l, p_idsel, s_ad, s_cbe_l, s_par, s_perr_l, s_serr_l, s_frame_l, s_irdy_l, s_trdy_l, s_lock_l, s_devsel_l, and s_stop_l.

Table 45. 66 MHz PCI Signal Timing

Symbol	Parameter	Minimum	Maximum	Unit
T_{val}	CLK to signal valid delay—bused signals ^{1,2,3}	2	6	ns
$T_{val(ptp)}$	CLK to signal valid delay—point-to-point ^{1,2,3}	2	6	ns
T_{on}	Float to active delay ^{1,2,3}	2	—	ns
T_{off}	Active to float delay ^{1,2}	—	14	ns
T_{su}	Input setup time—bused signals ^{1,2,3}	3	—	ns
$T_{su(ptp)}$	Input setup time to CLK—point-to-point ^{1,2,3}	5	—	ns
T_h	Input signal hold time from CLK ^{1,2}	0	—	ns

1. See Figure 23.

2. All primary interface signals are synchronized to p_clk. All secondary interface signals are synchronized to s_clk.

3. Point-to-point signals are p_req_l, s_req_l<8:0>, p_gnt_l, and s_gnt_l<8:0>. Bused signals are p_ad, p_cbe_l, p_par, p_perr_l, p_serr_l, p_frame_l, p_irdy_l, p_trdy_l, p_lock_l, p_devsel_l, p_stop_l, p_idsel, s_ad, s_cbe_l, s_par, s_perr_l, s_serr_l, s_frame_l, s_irdy_l, s_trdy_l, s_lock_l, s_devsel_l, and s_stop_l.

17.4.3 Reset Timing Specifications

Table 46 shows the reset timing specifications for p_rst_l and s_rst_l.

Table 46. Reset Timing Specifications (Sheet 1 of 2)

Symbol	Parameter	Minimum	Maximum	Unit
T_{rst}	p_rst_l active time after power stable	1	—	μs
$T_{rst-clk}$	p_rst_l active time after p_clk stable	100	—	μs
$T_{rst-off}$	p_rst_l active-to-output float delay	—	40	ns
T_{srst}	s_rst_l active after p_rst_l assertion	—	40	ns

Table 46. Reset Timing Specifications (Sheet 2 of 2)

Symbol	Parameter	Minimum	Maximum	Unit
$T_{srst-on}$	s_rst_l active time after s_clk stable	100	—	μs
T_{drrst}	s_rst_l deassertion after p_rst_l deassertion	20	25	Cycles
	p_rst_l slew rate ¹	50	—	mV/ns

¹: Applies to rising (deasserting) edge only.

17.4.4 gpio Timing Specifications

Table 47 and Table 48 show the gpio timing specifications. See also Figure 24.

Table 47. 33 MHz gpio Timing Specifications

Symbol	Parameter	Minimum	Maximum	Unit
T_{vgpio}	s_clk-to-gpio output valid	—	12	ns
T_{gon}	gpio float-to-active delay	2	—	ns
T_{goff}	gpio active-to-float delay	—	28	ns
T_{gsu}	gpio-to-s_clk setup time	7	—	ns
T_{gh}	gpio hold time after s_clk	0	—	ns
T_{gcval}	s_clk-to-gpio<0> shift clock output valid	—	13.5	ns
T_{gcyc}	gpio<0>cycle time	30	∞	ns
T_{gsval}	gpio<0>-to-<gpio<2> shift control output valid	—	8	ns
T_{msu}	msk_in setup time to gpio<0>	15	—	ns
T_{mh}	msk_in hold time after gpio<0>	0	—	ns

Table 48. 66 MHz gpio Timing Specifications

Symbol	Parameter	Minimum	Maximum	Unit
T_{vgpio}	s_clk-to-gpio output valid	—	12	ns
T_{gon}	gpio float-to-active delay	2	—	ns
T_{goff}	gpio active-to-float delay	—	28	ns
T_{gsu}	gpio-to-s_clk setup time	7	—	ns
T_{gh}	gpio hold time after s_clk	0	—	ns
T_{gcval}	s_clk-to-gpio<0> shift clock output valid	—	13.5	ns
T_{gyc}	gpio<0>cycle time	30	∞	ns
T_{gsval}	gpio<0>-to-<gpio<2> shift control output valid	—	8	ns
T_{msu}	msk_in setup time to gpio<0>	15	—	ns
T_{mh}	msk_in hold time after gpio<0>	0	—	ns

17.4.5 JTAG Timing Specifications

Table 49 shows the JTAG timing specifications.

Table 49. JTAG Timing Specifications (Sheet 1 of 2)

Symbol	Parameter	Minimum	Maximum	Unit
T_{jf}	tck frequency	0	10	MHz
T_{jp}	tck period	100	∞	ns
T_{jht}	tck high time	45	—	ns
T_{jlt}	tck low time	45	—	ns
T_{jrt}	tck rise time ¹	—	10	ns
T_{jft}	tck fall time ²	—	10	ns
T_{js}	tdi, tms setup time to tck rising edge	10	—	ns

Table 49. JTAG Timing Specifications (Sheet 2 of 2)

Symbol	Parameter	Minimum	Maximum	Unit
T_{jh}	tdi, tms hold time from tck rising edge	25	—	ns
T_{jd}	tdo valid delay from tck falling edge ³	—	30	ns
T_{jfd}	tdo float delay from tck falling edge	—	30	ns

¹. Measured between 0.8 V and 2.0 V.

². Measured between 2.0 V and 0.8 V.

³. C1 = 50 pF.

18.0 Mechanical Specifications

The 21150 is contained in an industry-standard 208-pin plastic quad flat pack (PQFP) package, shown in Figure 25.

Figure 25. 208-Pin PQFP Package

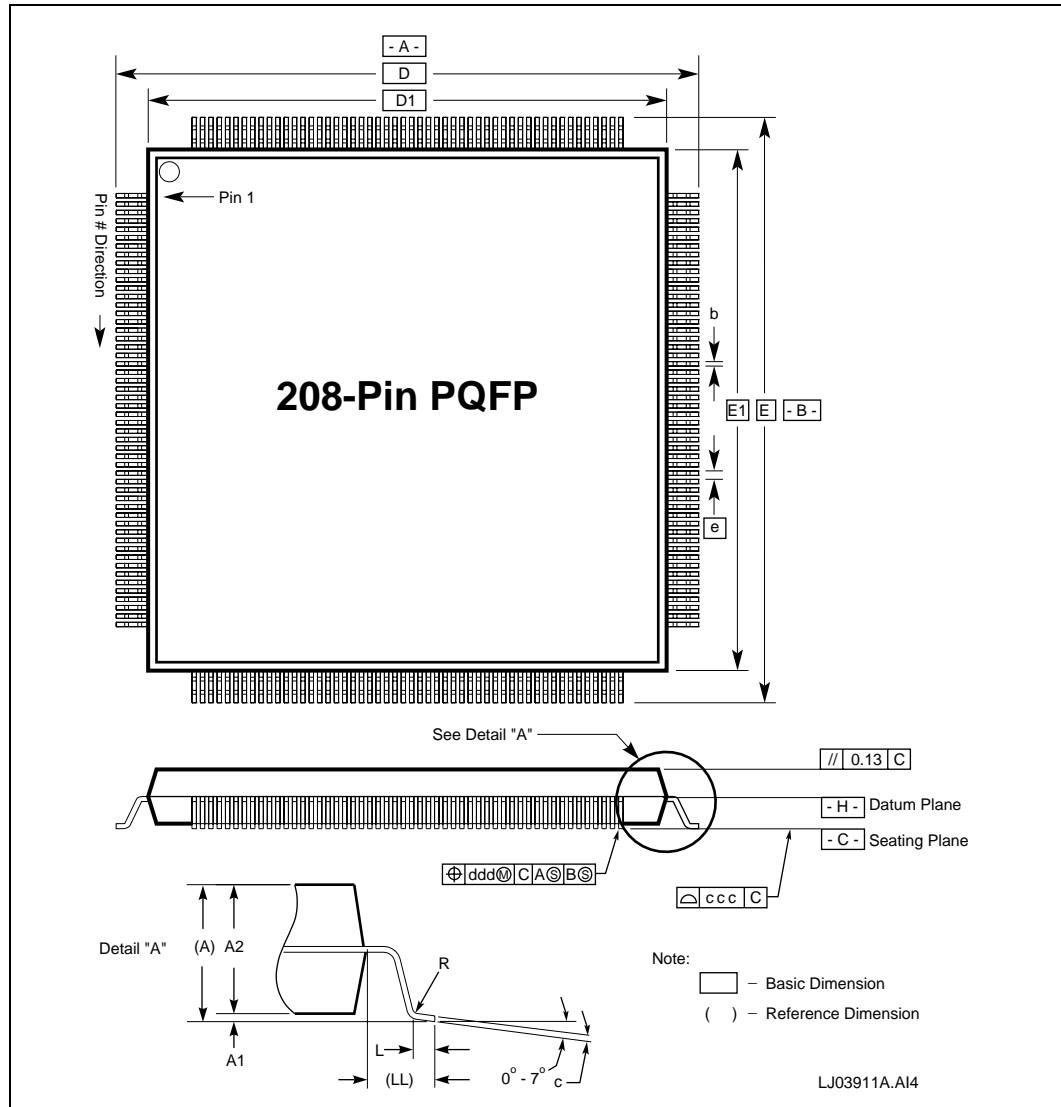

Table 50 lists the 208-pin package dimensions in millimeters.

Table 50. 208-Pin PQFP Package Dimensions

Symbol	Dimension	Value (mm)
LL	Lead Length	1.30 reference ¹
e	Lead pitch	0.50 BSC ²
L	Foot length	0.45 minimum to 0.75 maximum
A	Package overall height	4.20 reference ¹
A1 ¹	Package standoff height	0.25
A2 ²	Package thickness	3.17 minimum to 3.95 maximum
b	Lead width	0.17 minimum to 0.27 maximum
c	Lead thickness	0.09 minimum to 0.20 maximum
ccc	Coplanarity	0.08
ddd	Lead skew	0.08
D	Package overall width	30.60 BSC ²
D1 ¹	Package width	28.00 BSC ²
E	Package overall length	30.60 BSC ²
E1 ¹	Package length	28.00 BSC ²
R	Ankle radius	0.08 minimum to 0.25 maximum

¹ The value for this measurement is for reference only.

² ANSI Y14.5M-1982 American National Standard Dimensioning and Tolerancing, Section 1.3.2, defines Basic Dimension (BSC) as: A numerical value used to describe the theoretically exact size, profile, orientation, or location of a feature or datum target. It is the basis from which permissible variations are established by tolerances on other dimensions, in notes, or in feature control frames.



Support, Products, and Documentation

If you need technical support, a *Product Catalog*, or help deciding which documentation best meets your needs, visit the Intel World Wide Web Internet site:

<http://www.intel.com>

Copies of documents that have an ordering number and are referenced in this document, or other Intel literature may be obtained by calling **1-800-332-2717** or by visiting Intel's website for developers at:

<http://developer.intel.com>

You can also contact the Intel Massachusetts Information Line or the Intel Massachusetts Customer Technology Center. Please use the following information lines for support:

For documentation and general information:	
Intel Massachusetts Information Line	
United States:	1-800-332-2717
Outside United States:	1-303-675-2148
Electronic mail address:	techdoc@intel.com

For technical support:	
Intel Massachusetts Customer Technology Center	
Phone (U.S. and international):	1-978-568-7474
Fax:	1-978-568-6698
Electronic mail address:	techsup@intel.com