

General Description

The AAT4901 FastSwitch™ is a member of AnalogicTech's Application Specific Power MOSFET™ (ASPM™) product family. It is a full-bridge buffered power stage operating with an input voltage range of 2.0V to 5.5V. The device is designed to operate with a switching frequency of up to 2MHz, minimizing the cost and size of external components. The AAT4901 is protected from shoot-through current by integrated break-before-make circuitry. The drivers can be independently controlled and their propagation delay, from input to output, is typically between 8ns-19ns dependent upon logic option.

Four options are offered providing a single input control, dual input control or as two independent half-bridges.

Other features include low $R_{DS(ON)}$ and low quiescent current allowing for high efficiency performance.

The AAT4901 is available in the space-saving, Pb-free 8-pin SC70JW package and is rated over the -40°C to +85°C temperature range.

Features

- V_{IN} Range: 2.0V–5.5V
- $R_{DS(ON)}$:
 - High-side 220m Ω
 - Low-side 160m Ω
- Break-Before-Make Shoot-Through Protection
- 4 Options
 - Single Control Input with Enable
 - Two Logic Versions
 - Dual Control Input with Brake Function
 - Dual Half-bridge
- Low Quiescent Current:
 - 10 μ A (max) DC
 - 4mA (max) at 1MHz
- -40°C to +85°C Temperature Range
- SC70JW-8 Package

Applications

- DC Motor Drive
- Door Locks
- Dual Low-Side MOSFET Gate Driver
- Fan Motors
- High Frequency DC/DC Converters
- High Speed Line Drive
- Proximity Detectors

Typical Applications

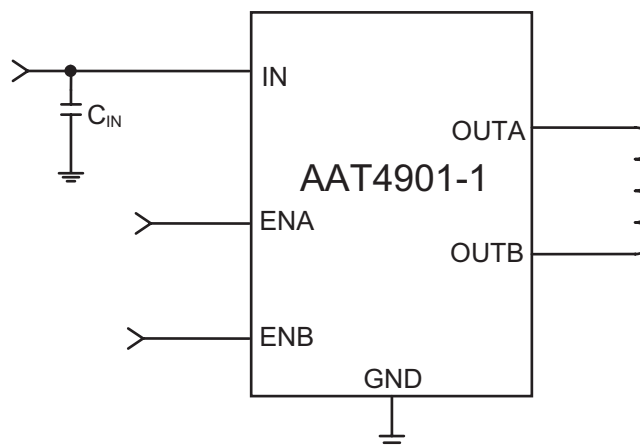

Pin Descriptions

Pin #	Symbol		Function
	-1, -2, -4	-3	
1	ENA		Active high enable signal.
2	IN		Supply voltage input; input voltage range from 2.0V to 5.5V.
3	ENB		Active high enable signal.
4	N/C	ENC	4901-1/-2/-4: No connection. 4901-3: Active high enable signal.
5	GND		Ground connection
6	OUTB		Output of half-bridge B. Connect to load.
7	OUTA		Output of half-bridge A. Connect to load.
8	N/C	END	4901-1/-2/-4: No connection. 4901-3: Active high enable signal.

Pin Configuration

SC70JW-8
(Top View)

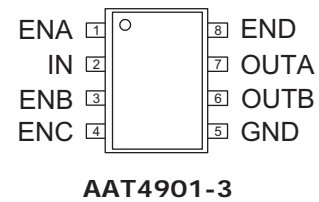
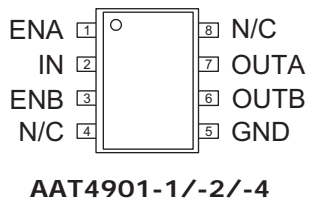

Absolute Maximum Ratings¹

Symbol	Description	Value	Units
V_{IN}	IN to GND	-0.3 to 6.0	V
V_{EN}	ENA, ENB, ENC, END to GND	-0.3 to $V_{IN} + 0.3$	V
V_{OUT}	OUT to GND	-0.3 to $V_{IN} + 0.3$	V
I_{MAX}	Maximum Continuous Switch Current	0.7	A
$I_{MAX(PK)}$	Maximum Peak Current	3	A
T_{LEAD}	Maximum Soldering Temperature (at Leads)	300	°C

Thermal Information

Symbol	Description	Value	Units
P_D	Maximum Power Dissipation ($T_A = 25^\circ\text{C}$)	440	mW
Θ_{JA}	Thermal Resistance ²	225	°C/W
T_J	Operating Junction Temperature Range	-40 to 150	°C

1. Stresses above those listed in Absolute Maximum Ratings may cause permanent damage to the device. Functional operation at conditions other than the operating conditions specified is not implied. Only one Absolute Maximum Rating should be applied at any one time.
 2. Mounted on a FR4 board.

Electrical Characteristics¹

$V_{IN} = 5V$, $T_A = -40$ to $85^\circ C$ unless otherwise noted. Typical values are at $T_A = 25^\circ C$.

Symbol	Description	Conditions	Min	Typ	Max	Units
V_{IN}	Operation Voltage		2.0		5.5	V
I_{QAC}	AC Quiescent Current	IN = 5V, ENB (D) = IN, ENA = 1MHz, $I_{OUT} = 0$	AAT4901-1	3.8	4.0	mA
			AAT4901-2	2.0		
			AAT4901-3	0.72		
			AAT4901-4	0.9		
I_{QDC}	DC Quiescent Current	IN = 5V, ENB (D) = IN, ENA (C) = GND, $I_{OUT} = 0$	AAT4901-1	5.5	10.0	μA
			AAT4901-2			
			AAT4901-3			
			AAT4901-4			
$I_{Q(OFF)}$	Off-Supply Current	ENB (D) = ENA (C) = GND, IN = OUT = 5.5V			1.0	μA
$I_{SD(OFF)}$	Off-Switch Current	ENB (D) = GND, IN = 5.5V, $V_{OUT} = 0$, or OUT = IN		0.03	1	μA
$R_{DS(ON)H}$	High Side MOSFET On-Resistance	$V_{IN} = 4.5V$		220		$m\Omega$
		$V_{IN} = 3.0V$		250		
		$V_{IN} = 2.0V$		340		
$R_{DS(ON)L}$	Low Side MOSFET On-Resistance	$V_{IN} = 4.5V$		160		$m\Omega$
		$V_{IN} = 3.0V$		180		
		$V_{IN} = 2.0V$		240		
V_{ONL}	ENA (C), ENB (D) Input Low Voltage				$0.2 \cdot V_{IN}$	V
V_{ONH}	ENA (C), ENB (D) Input High Voltage		$0.5 \cdot V_{IN}$			V
V_{HYS}	ENA (C), ENB (D) Input Hysteresis			$0.15 \cdot V_{IN}$		V
I_{SINK}	ENA (C), ENB (D) Input Leakage	ENA (C), ENB (D) = 5.5V		0.01	1.0	μA
T_{BBM}	Break-Before-Make Time	ENA (C) Rising		5.0		ns
		ENA (C) Falling		5.0		ns
T_{ON-DLY}	ENA (C) to OUT Delay	ENA (C) Rising	AAT4901-1	15		ns
			AAT4901-2	15		
			AAT4901-3	8		
			AAT4901-4	14		
		ENA (C) Falling	AAT4901-1	18		ns
			AAT4901-2	15		
			AAT4901-3	7		
			AAT4901-4	19		
T_{HIZ}	ENB to OUT HiZ Delay	ENA (C) = GND	AAT4901-1	12		ns
			AAT4901-2	10		
			AAT4901-3	10		
			AAT4901-4	12		
		ENA (C) = IN	AAT4901-1	11		ns
			AAT4901-2	10		
			AAT4901-3	7		
			AAT4901-4	12		

1. The AAT4901 is guaranteed to meet performance specifications over the $-40^\circ C$ to $+85^\circ C$ operating temperature range and is assured by design, characterization, and correlation with statistical process controls.

Typical Characteristics

AC Quiescent Current vs. Input Voltage
(ENB = IN; ENA = 1MHz; I_{OUT} = 0; T_A = 25°C)

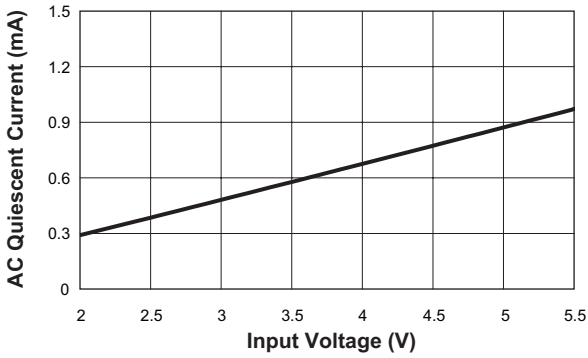

AC Quiescent Current vs. Input Voltage
(ENA = ENB = 1MHz; I_{OUT} = 0; T_A = 25°C)

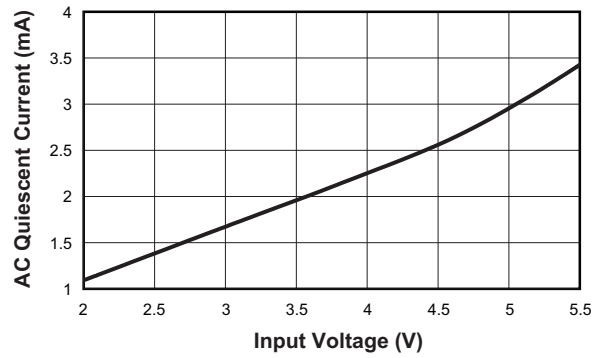

AC Quiescent Current vs. Switching Frequency
(ENB = IN; ENA = 0.1kHz~2000kHz; I_{OUT} = 0; T_A = 25°C)

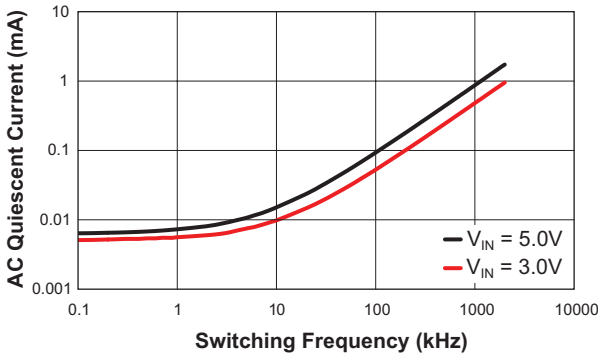

AC Quiescent Current vs. Switching Frequency
(ENA = ENB = 0.1kHz~2000kHz; I_{OUT} = 0; T_A = 25°C)

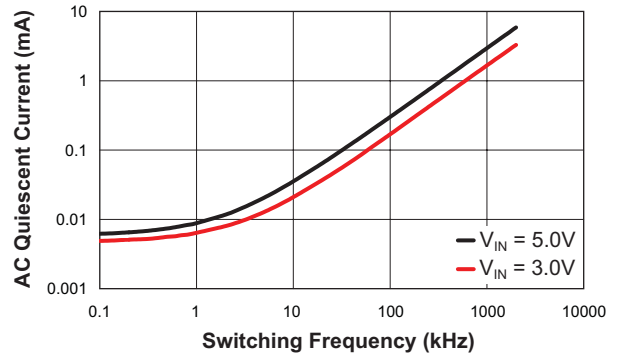

AC Quiescent Current vs. Temperature
(ENA = ENB = 1MHz; I_{OUT} = 0)

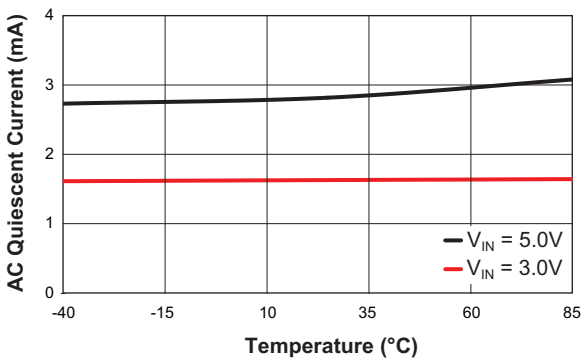

DC Quiescent Current vs. Temperature
(ENB = IN; ENA = GND; I_{OUT} = 0)

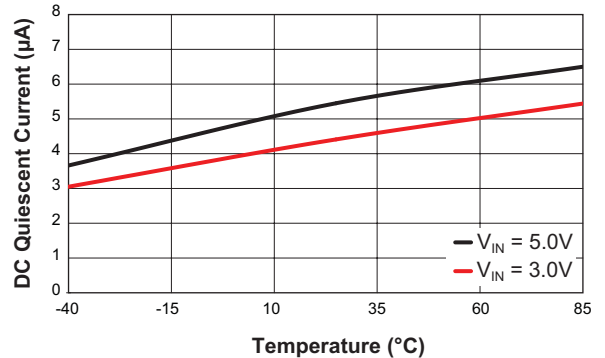

Typical Characteristics

Low Side $R_{DS(ON)}$ vs. Output Current
($T_A = 25^\circ\text{C}$)

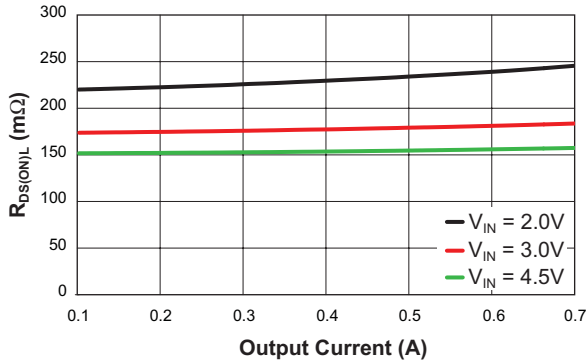

High Side $R_{DS(ON)}$ vs. Output Current
($T_A = 25^\circ\text{C}$)

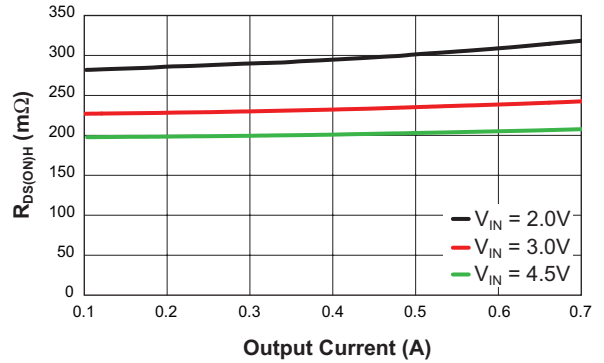

Low Side $R_{DS(ON)}$ vs. Temperature
($I_{OUT} = 0.7A$)

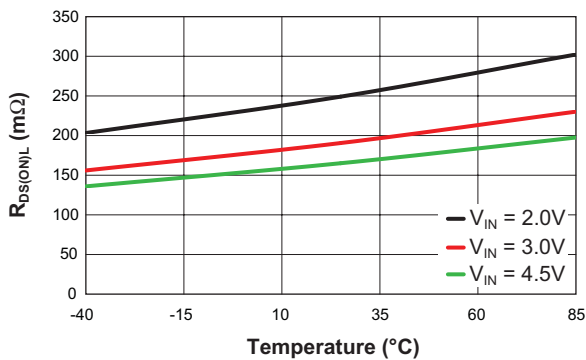

High Side $R_{DS(ON)}$ vs. Temperature
($I_{OUT} = 0.7A$)

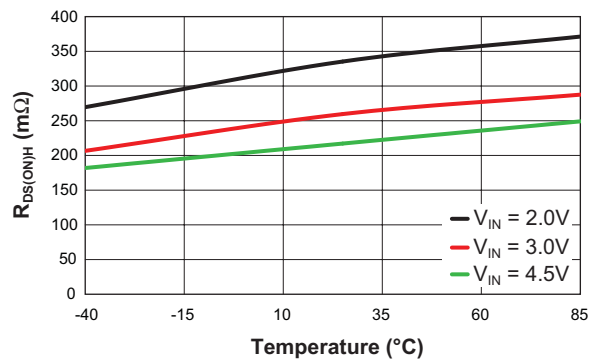

MOSFETs $R_{DS(ON)}$ vs. Input Voltage
($I_{OUT} = 0.7A$; $T_A = 25^\circ\text{C}$)

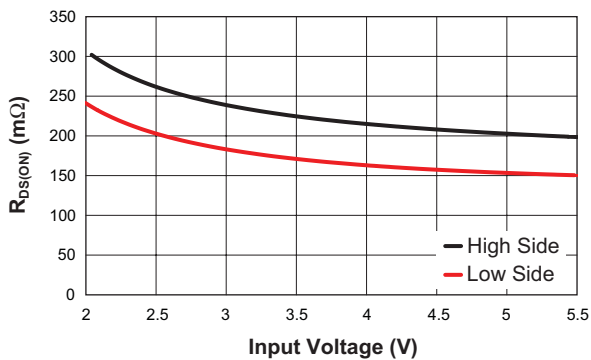

ENA/ENB Threshold vs. Input Voltage
($T_A = 25^\circ\text{C}$)

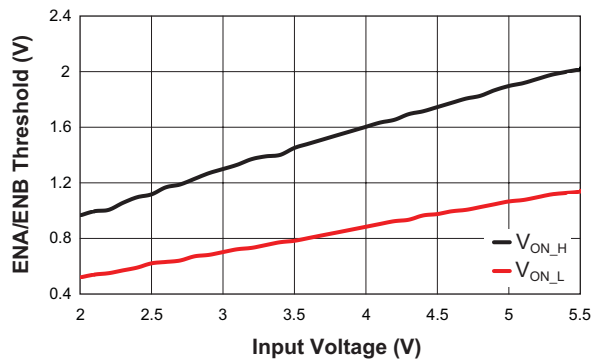

Functional Block Diagram

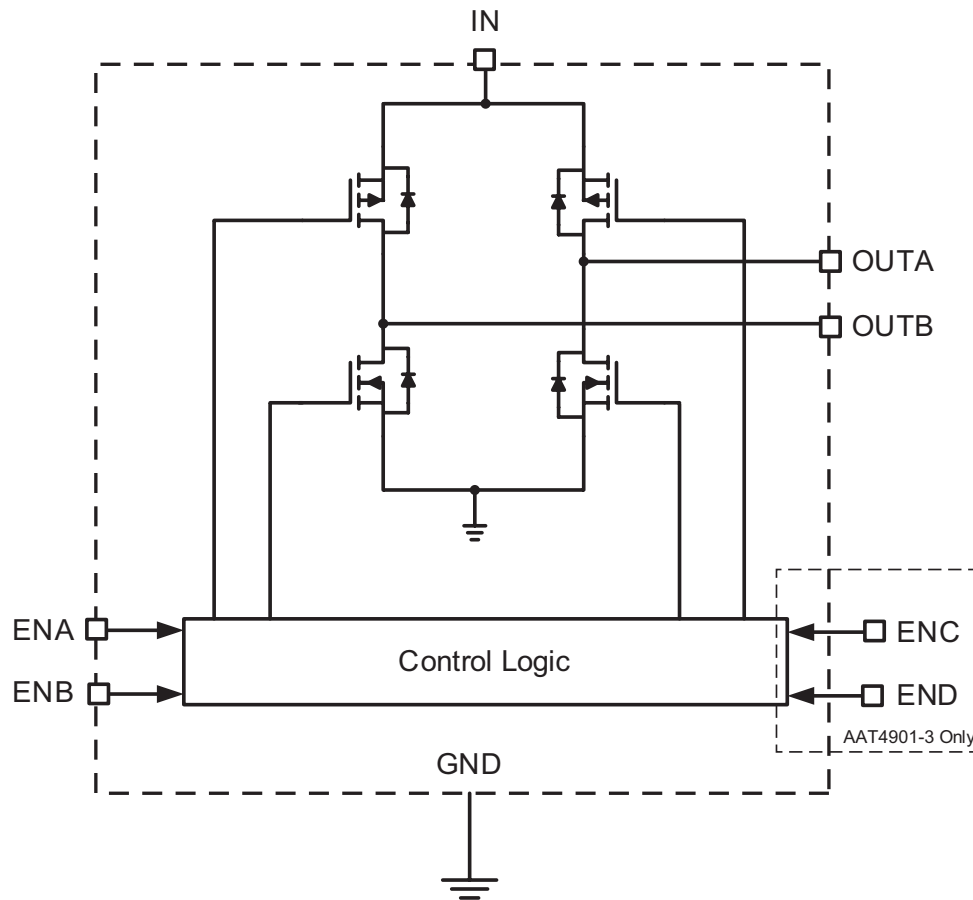

Functional Description

The AAT4901 is a buffered full-bridge driver IC with options to allow the device to function as two independent half-bridges. The output stage is capable of driving output loads of up to 0.7A and features break-before-make timing and very fast propagation delay time, allowing high

switching speed up to 2MHz. The enable input (EN), when driven low, turns off the driver and reduces the operating current to less than 1µA. Logic options allow the AAT4901 to be used as a small DC motor driver with break function, a solenoid driver, a dual-low-side MOSFET driver, or as a coil driver. Applications include motor drive, proximity detectors, electronic locks, and DC-DC converters.

Options

AAT4901-1

H-bridge configuration with two enables. Enable B is active high and enables the H-bridge output. Enable A toggles the H-bridge outputs A and B in anti-phase. In steady state, this can provide forward/reverse motor drive signals.

AAT4901-2

H-bridge configuration with two enables. Enable A and Enable B are in anti-phase and provide forward/reverse and braking.

AAT4901-3

Dual independent half-bridge configuration with four enables. Function similar to 2 x AAT4900.

AAT4901-4

H-bridge with two enables. Enable A and Enable B are in anti-phase and toggle the H-bridge outputs A and B in anti-phase respectively. In steady state, this can provide forward/reverse motor drive signals to adjust the motor speed by various duty cycles.

AAT4901-1/-4 Logic Table

-1		-4		OUTA	OUTB
ENA	ENB	ENA	ENB		
0	0	0	0	Hi Z	Hi Z
1	0	1	1	Hi Z	Hi Z
0	1	1	0	IN	GND
1	1	0	1	GND	IN

AAT4901-2 Logic Table

ENA	ENB	OUTA	OUTB
0	0	Hi Z	Hi Z
1	0	IN	GND
0	1	GND	IN
1	1	IN	IN

AAT4901-3 Logic Table

ENA/C	ENB/D	OUTA/B
0	0	Hi Z
1	0	Hi Z
0	1	IN
1	1	GND

Timing Diagram

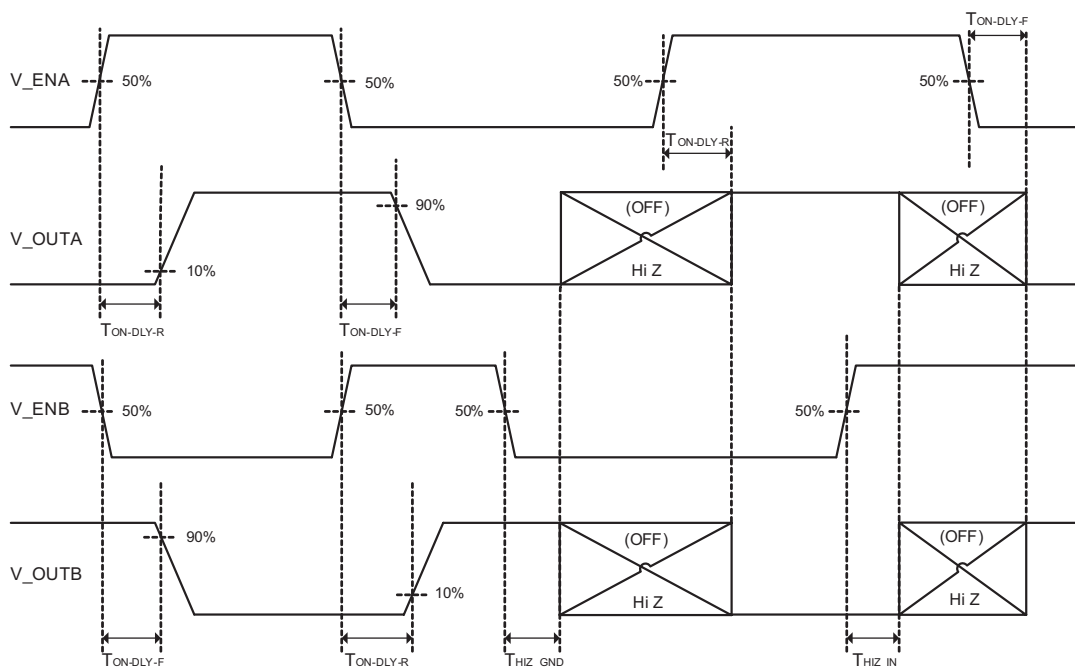

Figure 1: AAT4901-4 Timing Diagram.

Application Information

Input Supply Capacitor

The input capacitor provides a low impedance loop for the edges of pulsed current drawn by the AAT4901 and reduces the surge current drawn from the input power. A 4.7µF to 10µF X7R or X5R low ESR/ESL ceramic capacitor is selected for the input supply decoupling. To minimize the tray resistance, the capacitor should be placed as closely as possible to the input pin. This keeps the high frequency content of input current localized, minimizing EMI and input voltage ripple.

Shoot-Through Protection

The internal high-side and low-side MOSFETs of the AAT4901 cannot conduct at the same time to prevent shoot-through current. When the high-side MOSFET turns on, the low-side MOSFET turns off first; after 5ns break-before-make time, the high-side MOSFET then turns on. Similarly, before the low-side MOSFET turns on, the high-side MOSFET turns off; after a certain break-before-make time (5ns typ.), the low-side MOSFET turns on. The dead time between the high-side and low-side turn-on should be kept as low as possible to minimize current flows through the body diode of the high-side and/or low-side MOSFET(s). The break-before-make shoot-through protection significantly reduces losses associated with the driver at high frequency.

Thermal Calculations

In the dual low-side MOSFET driver application, the power dissipation of the AAT4901 includes the power dissipation in the MOSFETs due to charging and discharging the gate capacitance, the AC quiescent current power dissipation, and transient power in the driver during output transitions. As the transient power is usually very small, its losses can be ignored. Maximum package power dissipation can be estimated by the following equation:

$$\text{Eq. 1: } P_{D(\text{MAX})} = V_{CC} \cdot I_{IN} = \frac{T_{J(\text{MAX})} - T_A}{\theta_{JA}} \\ = I_{QAC} \cdot V_{CC} + Q_{G(\text{tot})} F_{SW} \cdot V_{CC}$$

Where:

$T_{J(\text{MAX})}$ = junction temperature of the dice (°C).

T_A = ambient temperature (°C).

θ_{JA} = thermal resistance (225°C/W).

I_{QAC} = AC quiescent current of the driver (mA).

$Q_{G(\text{tot})}$ = total gate charge of external low side MOSFETs (nC).

F_{SW} = switching frequency (MHz).

The maximum junction temperature for the SC70JW-8 package can be derived from Equation 1:

$$\text{Eq. 2: } T_{J(\text{MAX})} = P_{D(\text{MAX})} \cdot \theta_{JA} + T_A$$

For example, if the AAT4901 drives 2 AAT9560 MOSFETs whose maximum gate charge is specified as 13nC for $V_{GATE} = 5V$, the total power dissipation in the driver at a switching frequency of 1MHz equals:

$$P_{D(\text{tot})} = 2 \cdot (5V \cdot 13nC \cdot 1MHz) + 5V \cdot 4.0mA = 150mW$$

Gate Drive Current Ratings

Assuming that the maximum gate charge of the dual low-side MOSFETs are equal, the maximum gate drive capability for the designed maximum junction temperature without an external resistor can be derived from Equation 1:

$$\text{Eq. 3: } Q_{G(\text{MAX})} = \frac{1}{2 \cdot F_{SW}} \cdot \left(\frac{T_{J(\text{MAX})} - T_A}{\theta_{JA} \cdot V_{IN}} - I_{QAC} \right)$$

The relationship between gate capacitance, turn-on/turn-off time, and the MOSFET driver current rating can be determined by:

$$\text{Eq. 4: } I_{G(\text{MAX})} = C_{G(\text{MAX})} \cdot \frac{dV}{dt}$$

Where:

$I_{G(\text{MAX})}$ = peak drive current for a given voltage

$C_{G(\text{MAX})}$ = maximum gate capacitance

dV = MOSFET gate-to-source voltage

dt = rising time of MOSFET gate-to-source voltage

The relationship between $C_{G(MAX)}$, $Q_{G(MAX)}$, and V_{GATE} is given by:

$$\text{Eq. 5: } C_{G(MAX)} = \frac{Q_{G(MAX)}}{V_{GATE}}$$

The peak current drive requirements for a given MOSFET gate voltage can be derived from Equations 4 and 5:

$$\text{Eq. 6: } I_{G(MAX)} = \frac{Q_{G(MAX)}}{dt}$$

Design Example

$V_{IN} = 5V$
 $V_{GATE} = 5V$
 $F_{SW} = 1MHz$
 $\theta_{JA} = 225^{\circ}C/W$
 $I_{QAC} = 4.0mA$
 $T_{J(MAX)} = 120^{\circ}C$
 $T_A = 85^{\circ}C$
 $t_{RISE} = dt = 10ns$

$$Q_{G(MAX)} = \frac{1}{2 \cdot 1MHz} \cdot \left(\frac{120^{\circ}C - 85^{\circ}C}{225^{\circ}C/W \cdot 5V} - 4.0mA \right) = 13.6nC$$

$$C_{G(MAX)} = \frac{Q_{G(MAX)}}{V_{GATE}} = \frac{13.6nC}{5V} = 2.7nF$$

$$I_{G(MAX)} = \frac{Q_{G(MAX)}}{dt} = \frac{13.6nC}{10ns} = 1.36A$$

Typical Applications

2-Phase Synchronous Buck Converter

The most common AAT4901 applications include multi-phase DC/DC converter output power stages, DC motor drive, a dual low-side MOSFET driver, and a 3-state high-speed high-current line driver.

Figure 2 shows a typical configuration when used as a 2-phase buck converter power stage with synchronous rectification. The EN pin can be used to force outputs OUTA/OUTB to a high impedance state; this allows the output inductor to operate in discontinuous condition mode (DCM) and improves efficiency under light load conditions. The body diode associated with the low-side switching device gives the AAT4901 inductive switching capability, and clamps the LX node at one diode drop below GND during the break-before-make time. The multiphase buck converter assures a stable, high-performance topology for high currents and low voltages which are demanded in computers, workstation, telecom and datacom servers. Figure 3 illustrates output ripple current reduction due to 2-phase cancellation.

Motor Drive

The AAT4901 is ideally suited for use as an efficient output driver for DC brushless motor control due to its full bridge output stage with integrated MOSFETs. The inductive load switching capability of the AAT4901 eliminates the need for external diodes during commutation time. In applications where rotation is always in the same direction, a single half-bridge AAT4900 can be used to drive a DC motor. If needed to control the rotation in both directions, full-bridge motor control circuits can be applied as shown in Figure 4. In this configuration the motor can be controlled to run clockwise, counter-clockwise, stop rapidly ("regeneration" braking) or free run (coast) to a stop.

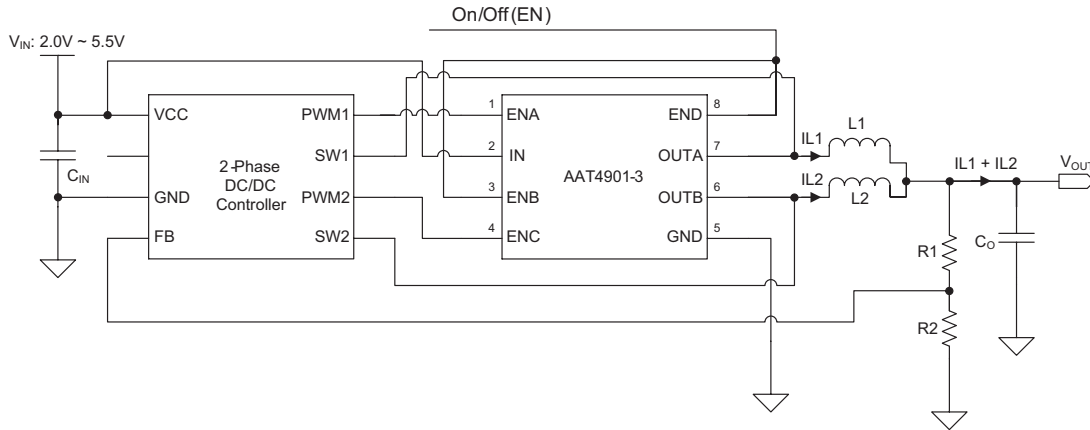

Figure 2: AAT4901 in 2-Phase Synchronous Buck Converter Power Stage.

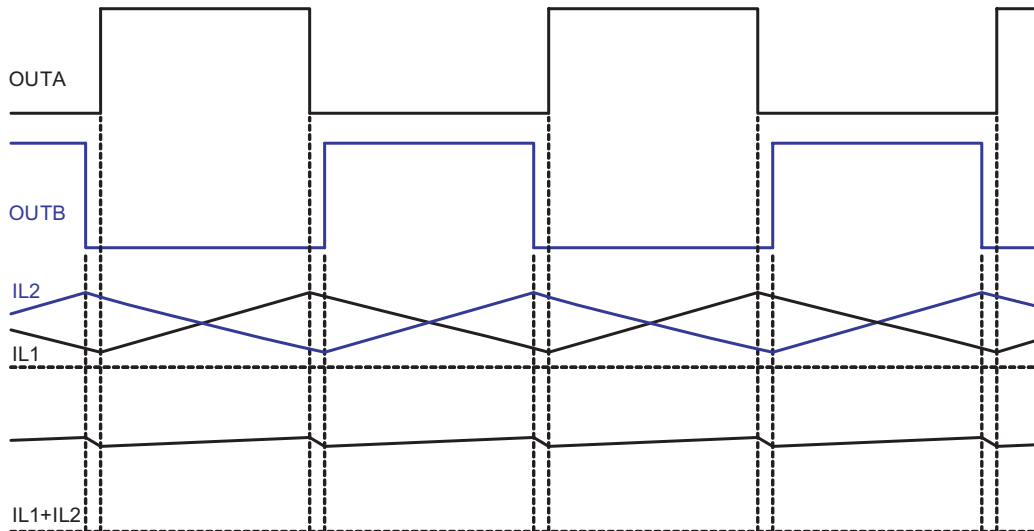

Figure 3: Output Current Ripple Reduction ($IL1 + IL2$) due to 2-Phase Cancellation.

When the voltage applied between the DC motor by the input(s) logic control is reversed, it could change the rotation direction. When both outputs (OUTA/OUTB) are floating, the motor winding acts as a regeneration; the current inside the motor winding would continue to flow into the input capacitor through the internal MOSFET parasitic diode and decay to zero rapidly, stopping the motor rapidly. When both outputs are connected to the input supply (or ground) simultaneously, the motor coasts and the winding current decays slowly due to the winding resistor until the motor free runs to a stop.

The speed of a DC motor is directly proportional to the supply voltage. It can be controlled by simply adjusting the voltage sent to the motor, but this is quite inefficient.

A better method is to switch the motor's supply on and off rapidly. If the switching is fast enough, the motor doesn't notice it, it only notices the average effect. The time it takes a motor to speed up and slow down under switching conditions is dependent on the inertia of the rotor (basically how heavy it is) and the amount of friction and load torque. Figure 5 shows the speed of a motor that is being turned on and off at a fairly low switching frequency. The average speed is around 150, although it varies quite a bit. If the supply voltage is switched quickly enough, the motor will not have time to change speed much and the speed will be quite steady. When the duty cycle ($D = T_{ON}/T$) is increased, the average speed of the motor increases. Thus the speed is controlled by the duty cycle of the PWM (Pulse Width Modulation).

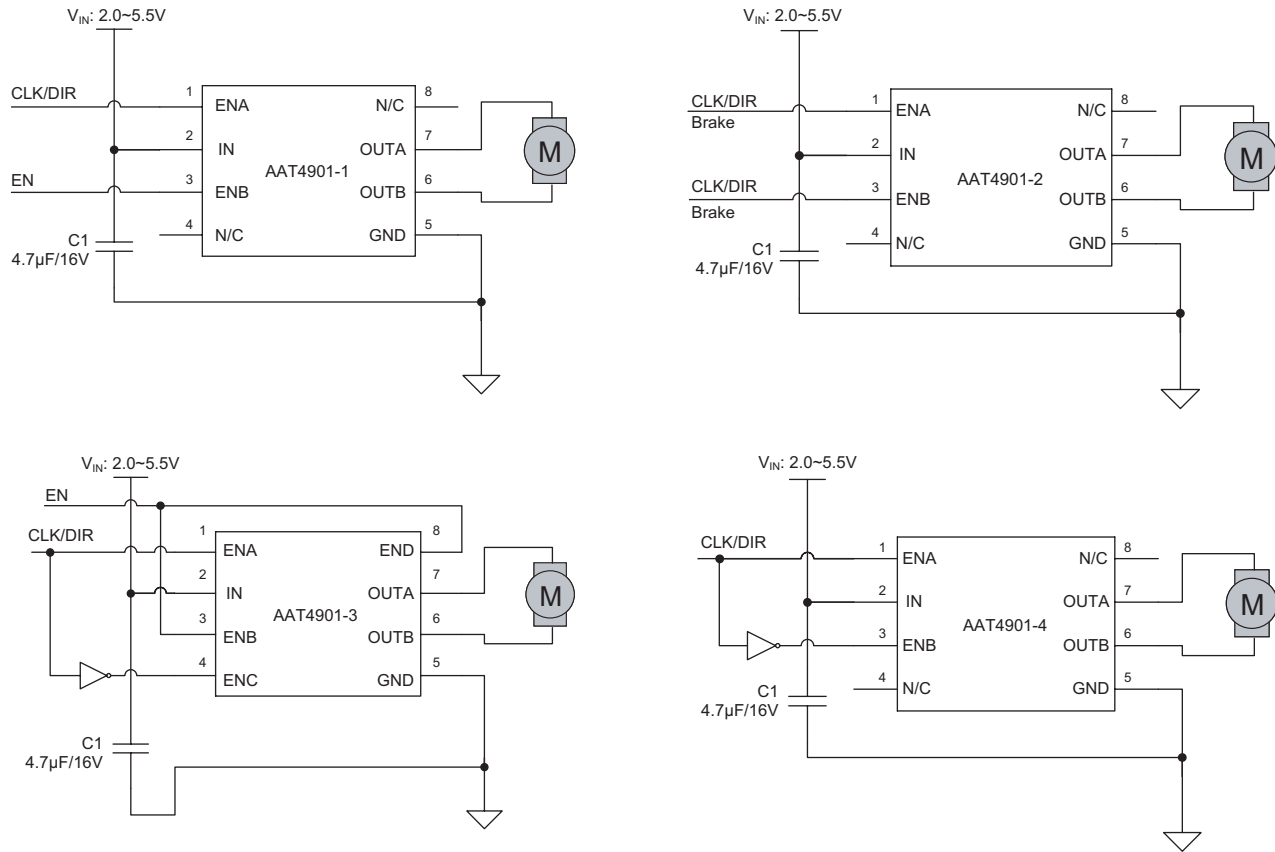

Figure 4: Full-Bridge Motor Driver Using AAT4901.

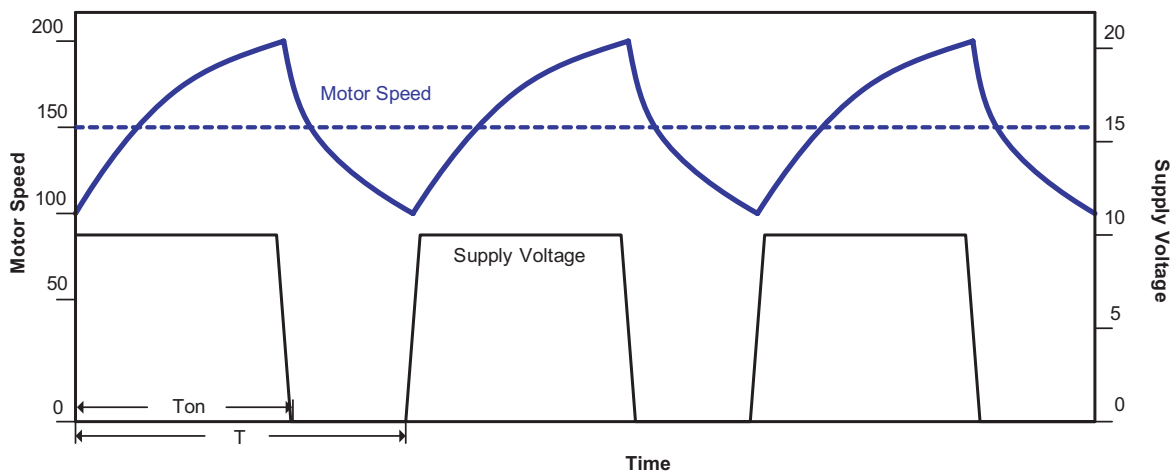

Figure 5: Motor Speed vs. Supply Voltage.

The minimum switching frequency is chosen based on motor characteristics (the equivalent inductance and the parasitic series resistor) and the percentage of current variation to the average current specified. The minimum switching frequency is in direct proportion to the parasitic series resistor, and in inverse proportion to the equivalent inductance and allowable current ripple.

When driving a high-voltage DC motor, external high-voltage MOSFETs are needed to commutate the motor. In this application, the AAT4901 can be configured as a double-ended gate driver, as illustrated in Figure 6.

The full-bridge power stage operates the motor drive control as shown in Figure 7. Each side of the motor can be connected either to the battery's positive terminal or to the battery's negative terminal through the switch. Note that only one MOSFET on each side of the motor may be turned on at any one time; otherwise the high-side and low-side MOSFETs will short out the battery and burn out.

There is also a diode connected in reverse across the field winding, to absorb the current in the field winding when all four MOSFETs in the bridge are turned off.

During period (A), to make the motor run forwards, Q4 is turned on, and Q1 has the PWM signal applied to it. The current path is shown in blue in Figure 7. At period (B) Q4 is kept on, so when the Q1 PWM signal is off, current can continue to flow around the bottom loop through Q3's parasitic diode. At period (C), to make the motor run backwards or control the speed, Q3 is turned on, and Q2 has the PWM signal applied to it. At period (D), Q3 is kept on, so when the Q2 PWM signal is off, current can continue to flow around the bottom loop through Q4's parasitic diode. At period (E), when the motor is running forwards for example, the motor is now acting as a generator and forcing current through its armature, through Q2's diode, through the battery (thereby charging the battery) and back through Q3's diode.

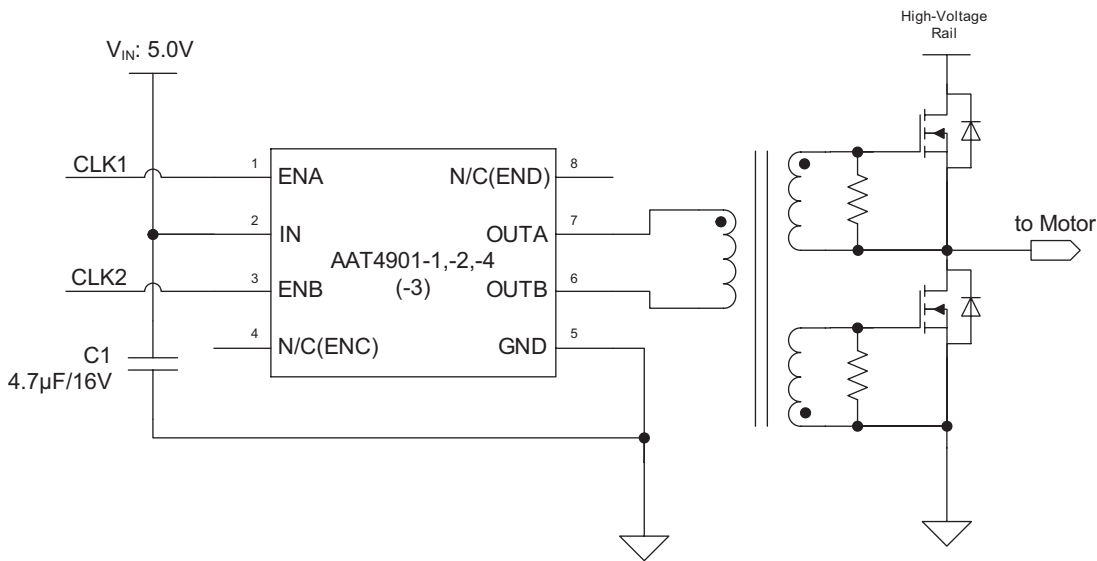
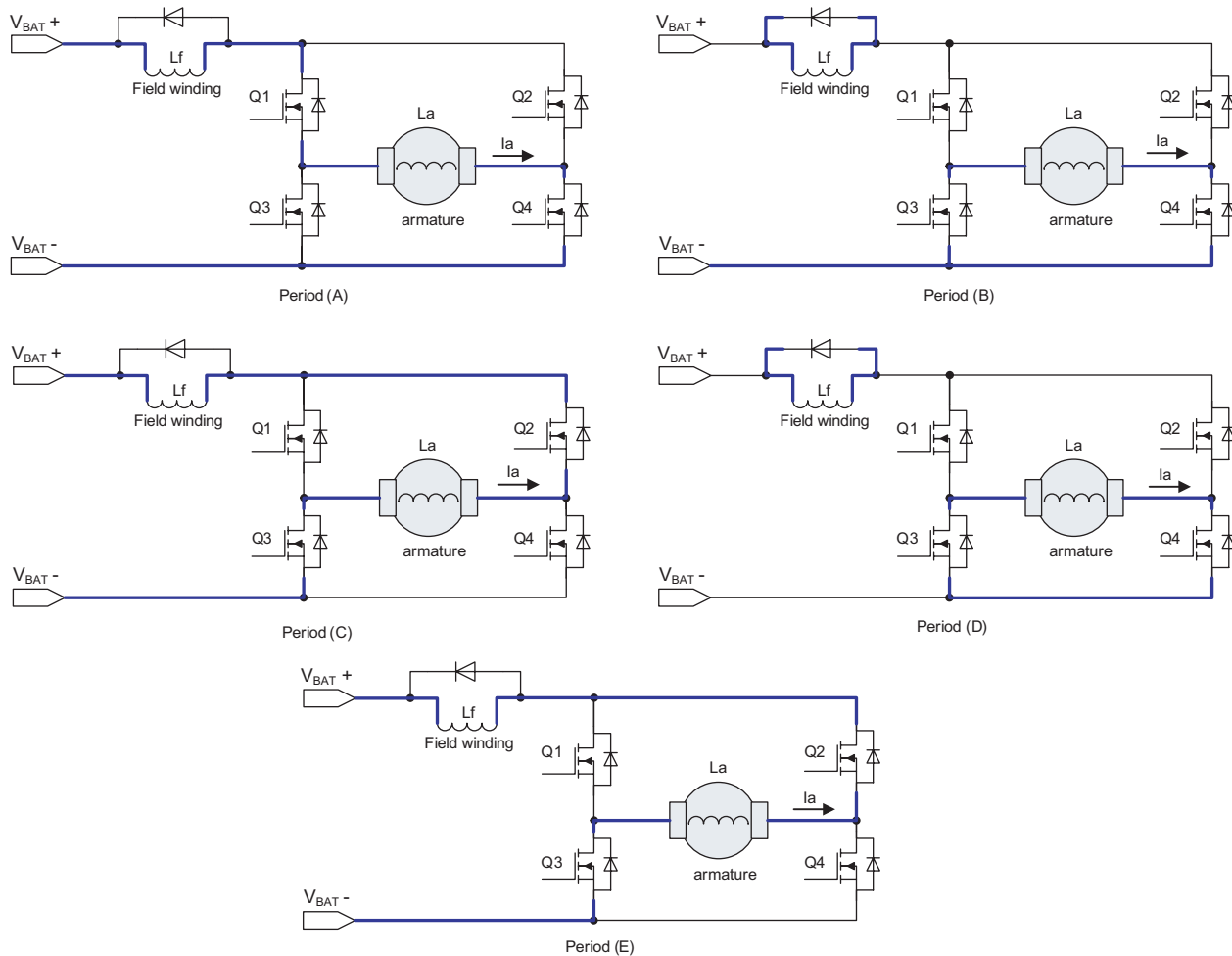

Figure 6: Double-Ended Gate Driver.

Figure 7: Full-Bridge Motor Drive Control.

Dual Channel, High Speed, High Current 3-State Line Driver

The AAT4901-3 is ideally suited for dual channel, high speed, high current 3-state line driver applications such as CCD clock drivers. The low quiescent power dissipation makes this part attractive in battery powered products. The 3A peak drive capability also makes the AAT4901-3 an excellent choice for driving high speed capacitive lines. The 20ns fast switching/delay time allows clocking speeds up to 10MHz.

Dual Low-Side MOSFET Driver

The AAT4901-3 is also ideally suited for dual low-side MOSFET driver applications due to its dual independent half-bridge output configuration. It can be used in a push-pull topology as illustrated in Figure 9 or in other applications which require the ability to drive the MOSFETs quickly, due to the AAT4901's extremely low $R_{DS(ON)}$ (220/160m Ω typ.) and very fast propagation time (20ns typ.)

Ordering Information

Package	Marking ¹	Part Number (Tape and Reel) ²
SC70JW-8	XXGY	AAT4901JJS-1-T1
SC70JW-8	XXGY	AAT4901JJS-2-T1
SC70JW-8	XXGY	AAT4901JJS-3-T1
SC70JW-8	2SGY	AAT4901JJS-4-T1



All AnalogicTech products are offered in Pb-free packaging. The term “Pb-free” means semiconductor products that are in compliance with current RoHS standards, including the requirement that lead not exceed 0.1% by weight in homogeneous materials. For more information, please visit our website at <http://www.analogictech.com/about/quality.aspx>.

Package Information

SC70JW-8

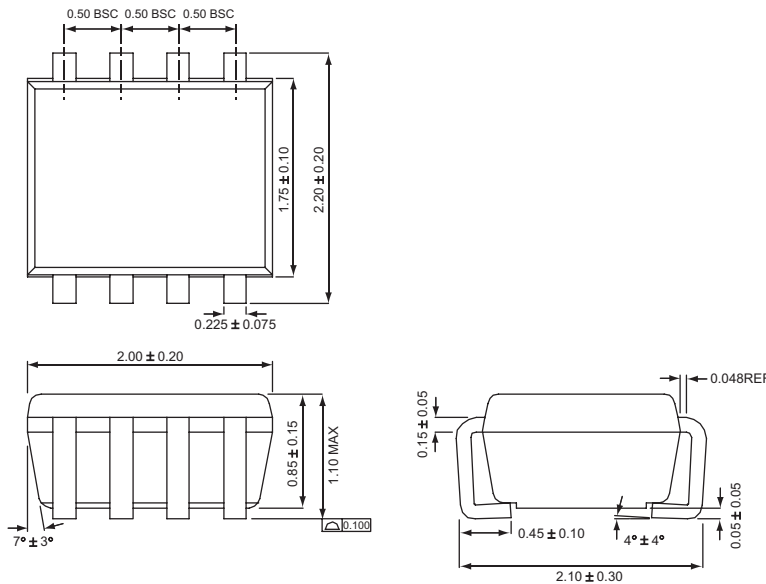

All measurements in millimeters.

1. XXGY: XX denotes Device code, G denotes assembly code, and YY denotes date code.
2. Sample stock is generally held on part numbers listed in **BOLD**.

Advanced Analogic Technologies, Inc.
 3230 Scott Boulevard, Santa Clara, CA 95054
 Phone (408) 737-4600
 Fax (408) 737-4611



© Advanced Analogic Technologies, Inc. AnalogicTech cannot assume responsibility for use of any circuitry other than circuitry entirely embodied in an AnalogicTech product. No circuit patent licenses, copyrights, mask work rights, or other intellectual property rights are implied. AnalogicTech reserves the right to make changes to their products or specifications or to discontinue any product or service without notice. Except as provided in AnalogicTech's terms and conditions of sale, AnalogicTech assumes no liability whatsoever, and AnalogicTech disclaims any express or implied warranty relating to the sale and/or use of AnalogicTech products including liability or warranties relating to fitness for a particular purpose, merchantability, or infringement of any patent, copyright or other intellectual property right. In order to minimize risks associated with the customer's applications, adequate design and operating safeguards must be provided by the customer to minimize inherent or procedural hazards. Testing and other quality control techniques are utilized to the extent AnalogicTech deems necessary to support this warranty. Specific testing of all parameters of each device is not necessarily performed. AnalogicTech and the AnalogicTech logo are trademarks of Advanced Analogic Technologies Incorporated. All other brand and product names appearing in this document are registered trademarks or trademarks of their respective holders.