

- 16 I/O Telemetry Encoder/ Decoder
- Enables Easy Radio Control
- Connects directly to RF Modules
- Simple CMOS/TTL Data Interface
- Performs all Data Encryption for Reliable Operation.
- Achieves Maximum Range From RF Modules
- Fast Activation / Deactivation Time
- 16 I/O Line Channels
- Decoder Learns up to 30 Transmitters
- Easy Learn transmitter function
- Compatible with 200, 204 and 207 series transmitters
- Outputs follow inputs in Real Time.
- One to many / many to one relationship.

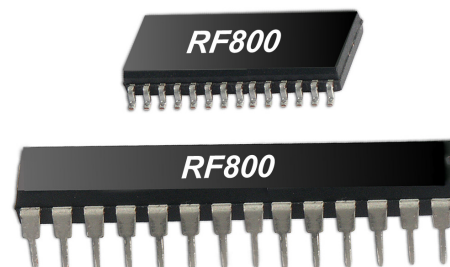

Hardware Features

- 4.0 – 5.5V Operation. (2.0 – 5.5V optional)
- 'Manchester' Modulation
- CRC Error Checking
- 28 pin DIP/SOIC Package
- 16 Digital I/O Telemetry Lines
- compatibility with 200 series transmitters

Typical Applications

Remote Telemetry
Alarm Systems
Communications Systems
High speed telemetry

Description

The RF800 is a single chip telemetry device, which may be an encoder or a decoder. When combined with a Radio transmitter / receiver it may be used to provide a remote control system with upto 16 I/O lines.

The RF800 performs all the necessary data manipulation and encryption for a optimum range reliable radio link whilst providing a simple user interface.

The device has been designed to obtain the maximum range from the Radio path using automatic data packet generation with 'Manchester' encoding and CRC based error checking.

The RF800 is compatible with the RF Solutions 200 series range of remote control products. An 'integrated' remote control can be generated using any of the 200 hand held transmitters.

Part Number	Description	Package
RF800	RF800 Encoder decoder IC PDIP package	28pin PDIP
RF800-SO	RF800 Encoder decoder IC SMT package	28pin SO

System Operation:

The RF800 is can be set to either encoder mode or decoder mode of operation. In all cases transmitters must be learnt to the RF800 decoder before any outputs will operate, thus enabling a secure telemetry system to be built with the possibility of several systems operating within a local environment.

Achieving Optimum Range

Range is dependant on many factors including:

1. RF Power output.
2. Receiver sensitivity.
3. Antenna efficiency.
4. Local environmental conditions and any local Interference.

Given that there is a legal maximum power output which can be transmitted, and a limit on the sensitivity of the receiver (usually constrained by cost), and that the antenna can never achieve 0dB loss (100% efficiency), then the data type is an important aspect of the design.

The RF800 devices use a fully balanced Manchester encoded data protocol designed for optimum use of the radio transmission path. This results in reduced bit errors and therefore ensures maximum range.

The data format automatically includes a pre-amble, synchronisation header, followed by the encrypted and fixed code data then a CRC check. The RF800 data packet contains a total of 150 bits, which takes 30ms to transmit when the RF800 is set to 200us element time. Thus if the element time is set to 400us it takes a total of 60ms to transmit one data packet.

Each RF800 is programmed at the time of manufacture with a unique 16-bit serial number, which provides a secure way of addressing RF800 devices. This provides upto 65,536 possible addresses.

Compatibility with 200 series Transmitters:

Acting as a decoder the RF800 is compatible with the 200 series of ready to operate transmitter encoders (such as the 204 handset as shown right).

To be compatible the RF800 must be setup as a decoder and have its element time set to 400us. This enables designers to easily integrate a remote control function into an application using a ready made transmitter.



Pin Descriptions:

RF Baud Rate:

The RF800 ICs are capable of being set to one of two RF data rates. The 100 / 400 Input allows selection of either 100 or 400 us element times on the RF serial data output. The input is read only at power up: a '1' sets 100 us and a '0' sets 400us. Please note that that the encoder and decoder must be set to the same element time. In order to operate an RF800 decoder with a 200 series transmitter the RF800 decoder must be set for 400us element time.

Mode Pin:

The RF800 device can be configured to act as either a decoder or an encoder. This selection is made using the mode pin. If the mode pin is held low the RF800 will act as a decoder and pin functions will be as the description for a decoder.

If the mode pin is held high then the RF800 will act as an encoder IC and the pin functions will be as the description for the encoder.

Oscillator:

The RF800 device requires an external oscillator running at 4 MHz, please refer to the microchip datasheet for the 16F876A if more detailed information is required.

TEN / LRN:

This is a dual function pin.

- When configured as a decoder: this pin acts as Learn pin, which enables the RF800 decoder to learn and record the address of compatible transmitters.
- When configured as an encoder: this pin acts as a transmitter enable. This is used for controlling the switching of power to the radio transmitter. This is an active high output.

TEN / 204:

This is a dual function pin.

- When configured as a decoder: this pin allows selection between momentary or latching mode when used with the 204 handheld transmitters.
- When configured as an encoder: this pin acts as a transmitter enable. This can be for controlling the switching of power to the radio transmitter. This is an active low output.

LED:

This is a dual function pin.

- When configured as a decoder: this pin acts as a learn LED drive output and gives indication of learn (and erase) progress.
- When configured as an encoder: acts as an LED drive output and gives indication of radio data transmission.

Typical application circuit for RF800 setup as a Decoder

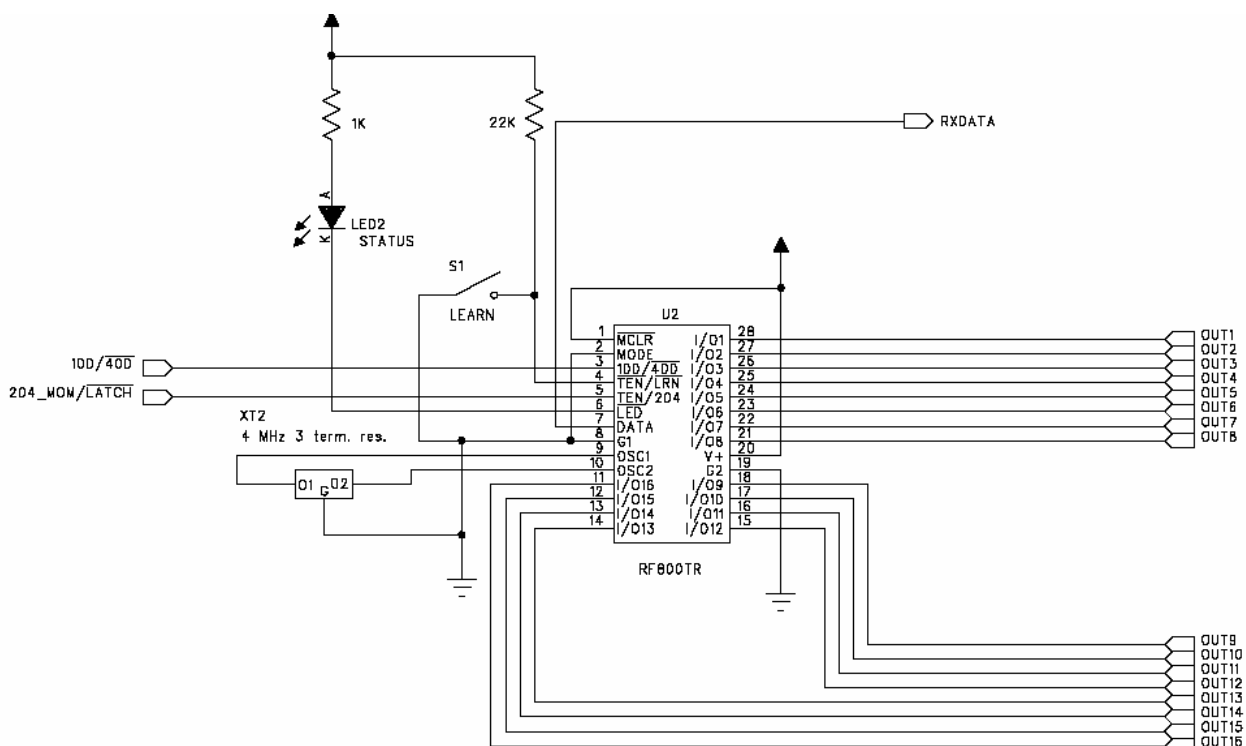

Pin Descriptions for RF800 configured as a Decoder

Pin Number	Name	Type	Description
1	MCLR	Power	Vcc supply voltage connection
2	Mode	In/Out	Selects operation as Decoder when low or Encoder when high.
3	100 / 400	In	RF baud rate (element time) select option. Logic '1' selects 100us element time. Logic '0' selects 400us element time.
4	TEN / LRN	In/Out	Learn button, puts RF800 Decoder into learn mode when momentarily connected to GND
5	TEN / 204	In/Out	Sets outputs to either latched or monetary for operation with the 204 handheld transmitter. Logic "1" selects momentary mode Logic "0" selects latching mode
6	LED	Out	Learn LED drive. Active low.
7	Data	In/Out	Received RF serial data
8 & 19	GND	Power	0 volts.
9	OSC1	In	Connect to 4MHz, 3 terminal resonator.
10	OSC2	Out	Connect to 4MHz, 3 terminal resonator.
11-18	Out 9-16	Out	Logic outputs 9 to 16 (active low)
20	Vcc	Power	Vcc supply voltage connection. Decouple with a 100nF capacitor close to the IC supply pins.
21-28	Out 1-8	Out	Logic outputs 1 to 8 (active low)



Learn Operation using momentary push switch (as application circuit for decoder)

1. Briefly press and release the learn switch.
2. The status LED will illuminate while the switch is pressed and remain on when released.
3. Operate the transmitter encoder once: status LED on the decoder will extinguish.
4. Operate the transmitter encoder a second time: status LED on the decoder will flash.
5. After the status LED has stopped flashing the encoder has been successfully taught to the decoder
6. This transmitter will now operate the system.

Erase operation using momentary push switch (as application circuit)

To completely erase all learned transmitters, press and hold the learn switch on the decoder for 10 seconds. The status LED will illuminate whilst the switch is held down and when it is released will flash while the decoder erases all memory. It may take several seconds until the erase function is complete. After the status LED is extinguished all the encoder identities are erased from the decoder's non-volatile EEPROM memory.



Typical application circuit for RF800 setup as an Encoder

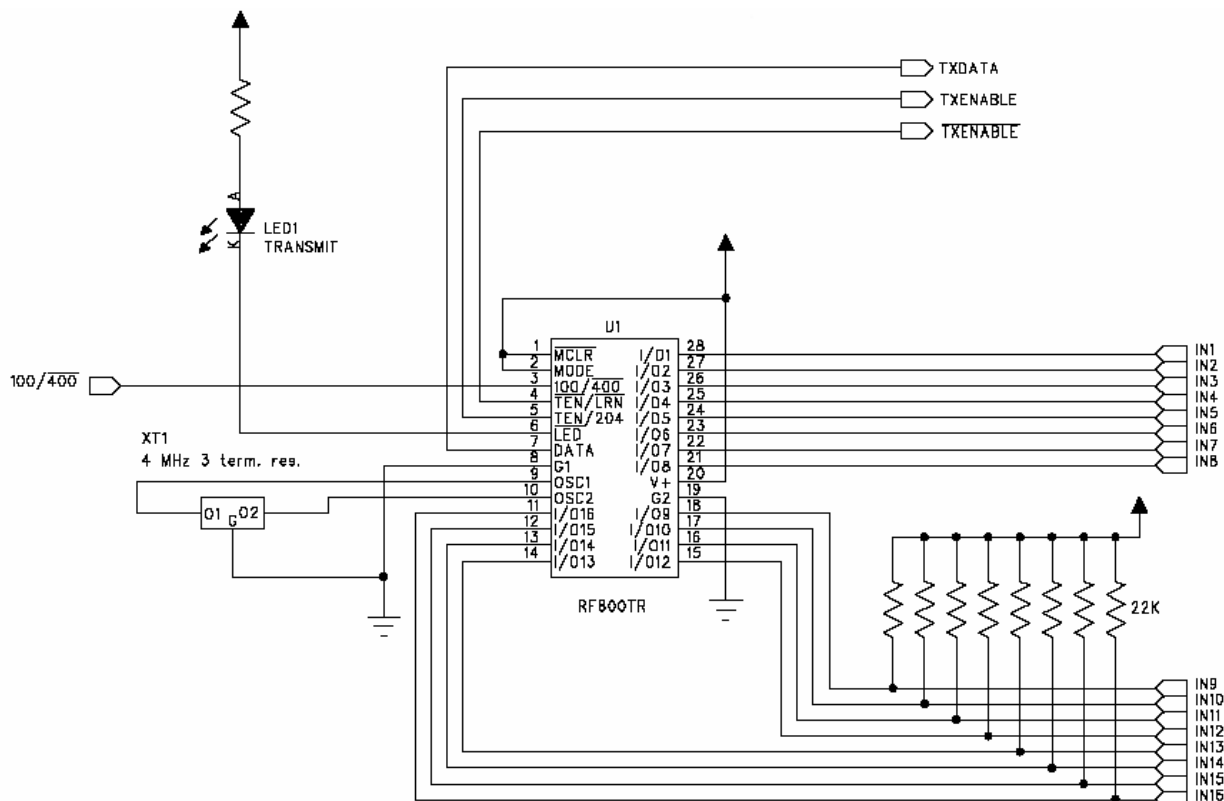

Pin Descriptions for RF800 configured as an Encoder

Pin Number	Name	Type	Description
1	MCLR	Power	Vcc supply voltage connection
2	Mode	In/Out	Selects operation as Decoder when low or Encoder when high.
3	100 / 400	In	RF baud rate (element time) select option. Logic '1' selects 100us element time. Logic '0' selects 400us element time.
4	TEN / LRN	In/Out	Transmitter enable active low
5	TEN / 204	In/Out	Transmitter enable active high
6	LED	Out	Status LED
7	Data	In/Out	Transmitted RF serial data
8 & 19	GND	Power	0 volts.
9	OSC1	In	Connect to 4MHz, 3 terminal resonator.
10	OSC2	Out	Connect to 4MHz, 3 terminal resonator.
11-18	IN 9-16	In	Logic inputs 9 to 16
20	Vcc	Power	Vcc supply voltage connection. Decouple with a 100nF capacitor close to the IC supply pins.
28-21	IN 1-8	In	Logic inputs 1 to 8



Technical Specifications:

Absolute Maximum Ratings

Note: Stresses above those listed under "Absolute Maximum Ratings" may cause permanent damage to the device.

Item	Rating	Units
Supply voltage	4 to 5.5	V
Input voltage	-0.3 to VDD + 0.3	V
Output voltage	-0.3 to VDD+ 0.3	V
Max output current	25	mA
Storage temperature	-55 to +125	°C (Note)
Lead soldering temp	300	°C (Note)
ESD rating	4000	V
Max O/P current sunk by any I/O pin	25	mA
Max O/P current sourced by any I/O pin	25	mA

RF800 Decoder/ Encoder

Electrical Characteristics	Min	Typical	Max	Unit
Operating current(average) Vdd = 5V		1.8	3.3	mA
Standby current		1.8	3.3	µA
High level Input voltage	.45 Vdd		Vdd	V
Low level input voltage	Vss		.2Vss	V
High level output voltage	Vdd-0.7			V
Low level output voltage			0.6	V
Output Pin Current rating			25	mA
LED sink current		5	25	mA

RF800E / 800D System Characteristics

Electrical Characteristics	Min	Typical	Max	Unit
Time from RF800E input operation to RF800D Output asserted: Element time of 100uSecs Element time of 400uSecs	16.6 66.4	16.8 66.6	17 66.8	mS
Time from RF800E input released to RF800D Output released: Element time of 100uSecs Element time of 400uSecs	16.6 66.4	16.8 66.6	17 66.8	mS
Decoder Momentary Output Time of operation	350			mS

Note that in momentary mode, the output will be asserted for as long as the 204 buttons are pressed.



28-Lead Skinny Plastic Dual In-line (SP) – 300 mil (PDIP)

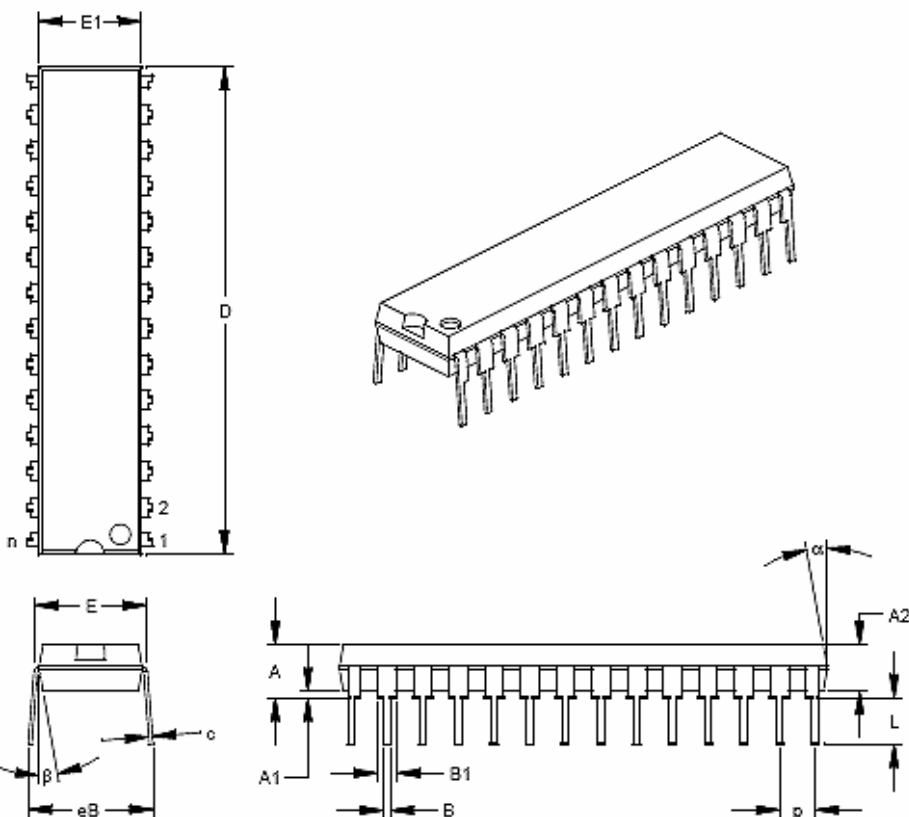

Dimension Limits	Units	INCHES*			MILLIMETERS		
		MIN	NOM	MAX	MIN	NOM	MAX
Number of Pins	n		28			28	
Pitch	P		.100			2.54	
Top to Seating Plane	A	.140	.150	.160	3.56	3.81	4.08
Molded Package Thickness	A2	.125	.130	.135	3.18	3.30	3.43
Base to Seating Plane	A1	.015			0.38		
Shoulder to Shoulder Width	E	.300	.310	.325	7.62	7.87	8.26
Molded Package Width	E1	.275	.285	.295	6.99	7.24	7.49
Overall Length	D	1.345	1.365	1.385	34.16	34.87	35.18
Tip to Seating Plane	L	.125	.130	.135	3.18	3.30	3.43
Lead Thickness	c	.008	.012	.015	0.20	0.29	0.38
Upper Lead Width	B1	.040	.053	.065	1.02	1.33	1.65
Lower Lead Width	B	.018	.019	.022	0.41	0.48	0.56
Overall Row Spacing	§ eB	.320	.350	.430	8.13	8.89	10.92
Mold Draft Angle Top	α	5	10	15	5	10	15
Mold Draft Angle Bottom	β	5	10	15	5	10	15

* Controlling Parameter

§ Significant Characteristic

Notes:

Dimension D and E1 do not include mold flash or protrusions. Mold flash or protrusions shall not exceed .010" (0.254mm) per side.

JEDEC Equivalent: MO-095

Drawing No. C04-070

28-Lead Plastic Small Outline (SO) – Wide, 300 mil (SOIC)

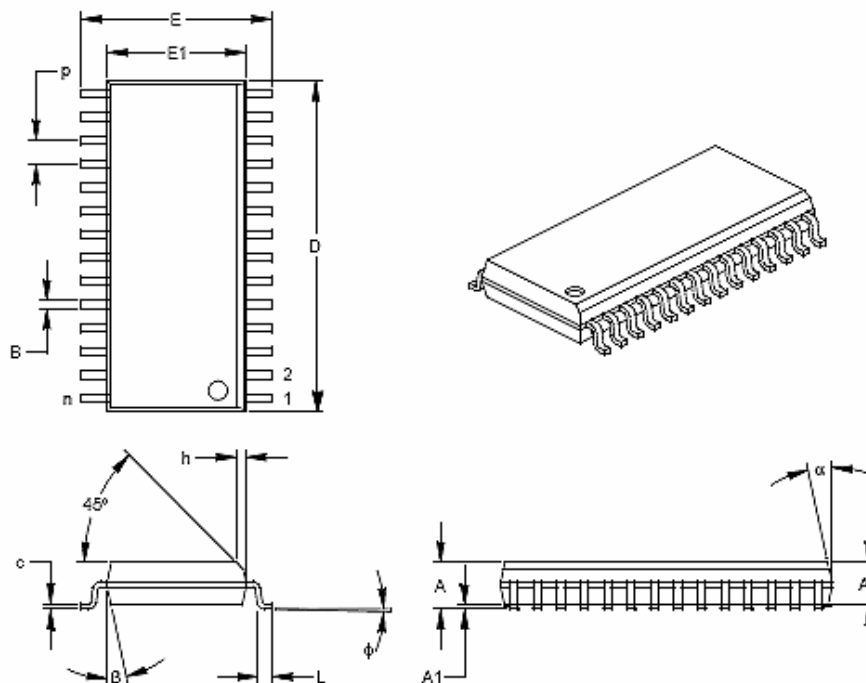

Dimension Limits	Units	INCHES*			MILLIMETERS		
	n	MIN	NOM	MAX	MIN	NOM	MAX
Number of Pins	n		.28			.28	
Pitch	p		.050			1.27	
Overall Height	A	.093	.099	.104	2.36	2.50	2.64
Molded Package Thickness	A2	.088	.091	.094	2.24	2.31	2.39
Standoff §	A1	.004	.008	.012	0.10	0.20	0.30
Overall Width	E	.394	.407	.420	10.01	10.34	10.67
Molded Package Width	E1	.288	.295	.299	7.32	7.49	7.59
Overall Length	D	.695	.704	.712	17.65	17.87	18.08
Chamfer Distance	h	.010	.020	.029	0.25	0.50	0.74
Foot Length	L	.016	.033	.050	0.41	0.84	1.27
Foot Angle Top	φ	0	4	8	0	4	8
Lead Thickness	c	.009	.011	.013	0.23	0.28	0.33
Lead Width	B	.014	.017	.020	0.36	0.42	0.51
Mold Draft Angle Top	α	0	12	15	0	12	15
Mold Draft Angle Bottom	β	0	12	15	0	12	15

* Controlling Parameter
 § Significant Characteristic

Notes:

Dimensions D and E1 do not include mold flash or protrusions. Mold flash or protrusions shall not exceed .010" (0.254mm) per side.

JEDEC Equivalent: MS-013

Drawing No. C04-052

R. F. Solutions Ltd.,
 Unit 21, Cliffe Industrial Estate, South Street, Lewes,
 E. Sussex, BN8 6JL, England

Tel +44 (0)1273 898 000

Fax +44 (0)1273 480 661

Email sales@rfsolutions.co.uk

<http://www.rfsolutions.co.uk>

RF Solutions is a member of the Low Power Radio Association

All Trademarks acknowledged and remain the property of the respected owners

Information contained in this document is believed to be accurate, however no representation or warranty is given and R.F. Solutions Ltd. assumes no liability with respect to the accuracy of such information. Use of R.F.Solutions as critical components in life support systems is not authorised except with express written approval from R.F.Solutions Ltd.