

SMD TYPE

LPF7028 SERIES

SMD Shielded type

SHAPES & DIMENSIONS RECOMMENDED PCB PATTERN

(Dimensions in mm)

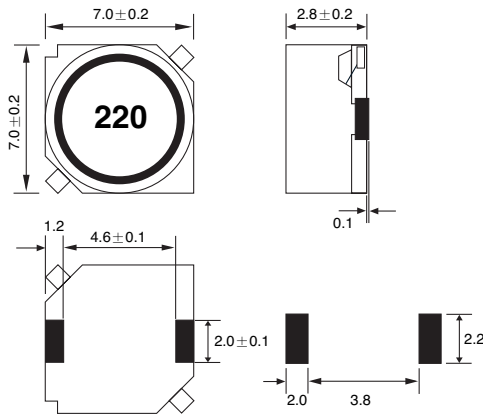

ELECTRICAL CHARACTERISTICS

Ordering Code	Inductance (μH)	Inductance TOL.(%)	Test Freq. (KHz)	DC Resistance (Ω)±20%	Rated Current(A)	
					IDC1 (Max.)	IDC2 (Ref.)
LPF7028T-3R3M	3.3	± 20	100	0.0250	2.00	2.7
LPF7028T-4R7M	4.7			0.0290	1.50	2.4
LPF7028T-6R8M	6.8			0.0370	1.30	2.1
LPF7028T-100M	10			0.0615	1.10	2.0
LPF7028T-150M	15			0.1000	0.88	1.6
LPF7028T-220M	22			0.1330	0.75	1.2
LPF7028T-330M	33			0.1850	0.65	1.1
LPF7028T-470M	47			0.2750	0.54	0.9
LPF7028T-680M	68			0.3950	0.45	0.7
LPF7028T-101M	100			0.5500	0.40	0.6

TEST EQUIPMENTS

- Inductance: Agilent 4284A LCR Meter (100KHz 0.5V)
- Rdc: HIOKI 3540 mΩ HiTESTER
- Bias Current: Agilent 4284A + Agilent 42841A
- IDC1(The saturation current): $\Delta L \leq 10\%$ at rated current
- IDC2(The temperature rise): $\Delta T = 20^\circ\text{C}$ at rated current

OPERATING TEMPERATURE RANGE

-20 ~ +85°C (Including self-generated heat)

LPF7030 SERIES

SMD Shielded type

Low RDC, High Current

SHAPES & DIMENSIONS RECOMMENDED PCB PATTERN

(Dimensions in mm)

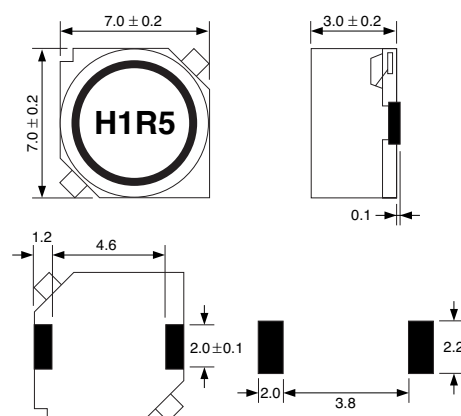

ELECTRICAL CHARACTERISTICS

Ordering Code	Inductance (μH)	Inductance TOL.(%)	Test Freq. (KHz)	DC Resistance (mΩ)Max	Rated Current(A)	
					IDC1 (Max.)	IDC2 (Ref.)
LPF7030T-1R0N	1.0	± 30	100	8.40	8.3	5.3
LPF7030T-1R5N	1.5			12.0	6.5	4.9
LPF7030T-2R2M	2.2	± 20	100	14.2	5.7	4.4
LPF7030T-3R3M	3.3			19.8	4.4	4.0
LPF7030T-4R7M	4.7			31.0	3.5	3.3
LPF7030T-6R8M	6.8			45.0	3.0	2.8
LPF7030T-100M	10			60.0	2.5	2.3

TEST EQUIPMENTS

- Inductance: Agilent 4284A LCR Meter (100KHz 0.5V)
- Rdc: HIOKI 3540 mΩ HiTESTER
- Bias Current: Agilent 4284A + Agilent 42841A
- IDC1(The saturation current): $\Delta L \leq 30\%$ at rated current
- IDC2(The temperature rise): $\Delta T = 35^\circ\text{C}$ at rated current

OPERATING TEMPERATURE RANGE

-40 ~ +105°C (Including self-generated heat)