



Low Jitter and Skew DC to 160MHz Clock Buffer

Key Features

- DC to 160 MHz operating frequency range
- Low output clock skew: 50ps-typ
- Low part-to-part output skew: 90 ps-typ
- 3.3V +/-10% operation supply voltage
- Low power dissipation:
 - - 7 mA-typ at 33MHz
 - - 8 mA-typ at 66MHz
 - - 12 mA-typ at 133MHz
- One input to four output fanout buffer drivers
- Output Enable (OE) control function
- Available in 8-pin TSSOP package
- Available in Commercial and Industrial grades
- Available in Lead (Pb) free package

Applications

- General Purpose PCI/PCI-X Clock Buffer
- Printers, MFPs and Digital Copiers
- PCs and Work Stations
- Routers, Switchers and Servers
- Datacom and Telecom
- High-Speed Digital Embedded Systems

Description

The SL2304NZ is a low skew, jitter and power fanout Buffer designed to produce up to four (4) clock outputs from one (1) reference input clock, for high speed clock distribution, including PCI/PCI-X applications.

The SL2304NZ products operate from DC to 160MHz.

The only difference between SL2304NZ-1 and SL2304NZ-1Z is the OE logic implementation. Refer to the Available OE Logic Configuration Table. 1

Refer to SL23EP04NZ products for DC to 220MHz-max frequency range, 2.5V to 3.3V power supply operation, improved skew, jitter and higher drive options.

Benefits

- Up to four (4) distribution of input clock
- Low skew
- Low Jitter
- Low power dissipation

Block Diagram

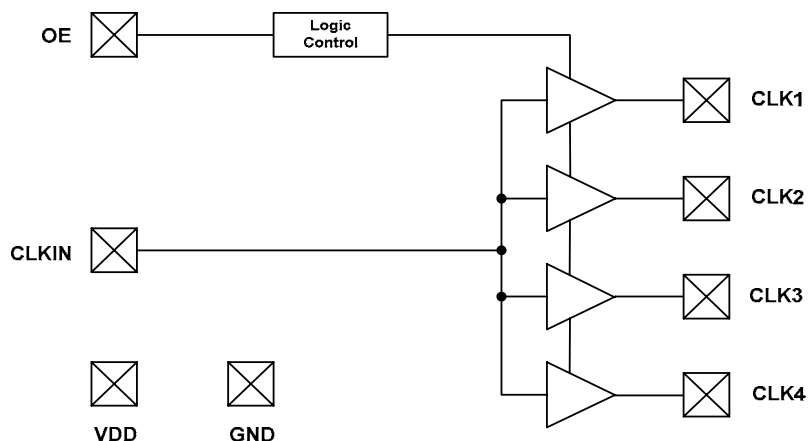

Pin Configuration

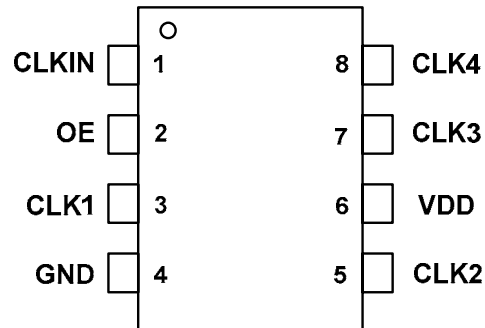

Pin Description

Pin Number	Pin Name	Pin Type	Pin Description
1	CLKIN	Input	Reference Clock Input
2	OE	Output	Output Enable. Refer to the Table. 1 for Logic Table
3	CLK1	Output	Buffered Clock Output 1
4	GND	Power	Power Ground.
5	CLK2	Output	Buffered Clock Output 2
6	VDD	Output	3.3V Power Supply
7	CLK3	Power	Buffered Clock Output 3
8	CLK4	Input	Buffered Clock Output 4

General Description

The SL2304NZ is a low skew, jitter and power fanout Buffer designed to produce up to four (4) clock outputs from one (1) reference input clock, for high speed clock distribution, including PCI/PCI-X applications.

Input and output Frequency Range

The input and output frequency is the same (1x) for SL2304NZ-1 and SL2304NZ-1Z and operates from DC to 160MHz clock range with up to 25pF output load.

OE (Output Enable) Function

The only difference between SL2304-1 and SL2304NZ-1Z is the OE logic implementation. When OE=0, SL2304NZ-1 outputs are disabled and outputs are at Logic Low. In the case of SL2304NZ-1Z the outputs are at High-Z. Refer to the Available OE Logic Configuration Table. 1 below.

Output Clock Skew

All outputs should drive the similar load to achieve output-to-output skew and input-to-output delay specifications as given in the switching electrical tables.

Power Supply Range (VDD)

The SL2304NZ is designed to operate 3.3V+/-10% (3.63V-max to 2.97V-min) VDD power supply range. An internal on-chip voltage regulator is used to provide to constant power supply of 1.8V, leading to a consistent and stable electrical performance in terms of skew and jitter. The SL2304NZ I/O is powered by using VDD.

Refer to SL23EP04NZ products for DC to 220MHz-max frequency range, 2.5V to 3.3V power supply operation, improved skew, jitter and higher drive options.

Contact SLI for 1.8V power supply Fan-Out Buffer and ZDB products.

CLKIN (Pin-1)	OE (Pin-2)	SL2304NZ-1 CLKOUT [1:4]	SL2304NZ-1Z CLKOUT [1:4]
Low	Low	Low	High-Z
High	Low	Low	High-Z
Low	High	Low	Low
High	High	High	High

Table 1. Available SL2304 CLKIN and OE Logic Configurations

Absolute Maximum Ratings (All Products)

Description	Condition	Min	Max	Unit
Supply voltage, VDD		-0.5	4.6	V
All Inputs and Outputs		-0.5	VDD+0.5	V
Ambient Operating Temperature	In operation, C-Grade	0	70	°C
Ambient Operating Temperature	In operation, I-Grade	-40	85	°C
Storage Temperature	No power is applied	-65	150	°C
Junction Temperature	In operation, power is applied	–	125	°C
Soldering Temperature		–	260	°C
ESD Rating (Human Body Model)	MIL-STD-883, Method 3015	2000	–	V

Operating Conditions (C-Grade and VDD=3.3V)

Unless otherwise stated VDD= 3.3V+/- 10%, CL=15pF and Ambient Temperature range 0 to +70°C

Description	Symbol	Condition	Min	Typ	Max	Unit
Operating Voltage	VDD	VDD+/-10%	2.97	3.3	3.63	V
Operating Temperature	TA	Ambient Temperature	0	–	70	°C
Input Capacitance	VIH	Pins 1 and 2	–	5	7	pF
Output Capacitance	COUT	Pins 3, 5, 7 and 8	–	3	5	pF
Load Capacitance	CL	Pins 3, 5, 7 and 8	–	–	30	pF

DC Electrical Characteristics (C-Grade and VDD=3.3V)

Unless otherwise stated VDD= 3.3V+/- 10%, CL=15pF and Ambient Temperature range 0 to +70°C

Description	Symbol	Condition	Min	Typ	Max	Unit
Input Low Voltage	VINL	CLKIN and OE	–	–	0.8	V
Input High Voltage	VINH	CLKIN and OE	2.0	–	VDD+0.3	V
Input Low Current	IINL	0 < VIN < 0.8V	-5	+/-2	5	µA
Input High Current	IINH	2.4V < VIN < VDD	-5	+/-2	5	µA
Output Low Voltage	VOL1	IoL=24mA	–	–	0.80	V
	VOL2	IoL=12mA	–	–	0.55	V
Output High Voltage	VOH1	IoH=-24mA	2.0	–	–	V
	VOH1	IoH=-12mA	2.4	–	–	V
Power Supply Current	IDD1	CLKIN=33MHz CL=0 (No load at outputs)	–	7	10	mA
Power Supply Current	IDD2	CLKIN=66MHz CL=0 (No load at outputs)	–	8	12	mA
Power Supply Current	IDD3	CLKIN=133MHz CL=0 (No load at outputs)	–	12	18	mA

Switching Electrical Characteristics (C-Grade and VDD=3.3V)

Unless otherwise stated VDD= 3.3V+/- 10%, CL=15pF and Ambient Temperature range 0 to +70°C

Description	Symbol	Condition	Min	Typ	Max	Unit
Output Frequency Range	FOUT	CL=25pf	0	–	160	MHz
Input Duty Cycle	DC1	Measured at VDD/2	20	50	80	%
Output Duty Cycle	DC2	CL=15pF, Fout=66 MHz Measured at VDD/2	45	50	55	%
Output Duty Cycle	DC3	CL=15pF, Fout=133 MHz Measured at VDD/2	45	50	55	%
Output Rise Time	tr	CL=25pF, measured at 0.8V to 2.0V	–	–	1.5	ns
Output Fall Time	tf	CL=25pF, all versions, measured at 0.8V to 2.0V	–	–	1.5	ns
CLKIN High or Low Time	tHL	CLKIN=66MHz, CL=15pF	5	–	–	ns
		CLKIN=140MHz, CL=15pF	2	–	–	ns
Output to Output Skew	SKW1	Measured at VDD/2 and Outputs are equally loaded	–	50	100	ps
Part to Part Skew	SKW2	Measured at VDD/2 and Outputs are equally loaded	–	90	200	ps
Propagation Delay Time	PDT	Measured at VDD/2 from CLKIN to Output Clock rising edge and Outputs are equally loaded	–	3.0	3.8	ns
Cycle-to-Cycle Jitter	CCJ1	CLKIN=66MHz and CL=0 (No Load)	–	60	120	ps
Cycle-to-Cycle Jitter	CCJ2	CLKIN=133MHz and CL=0 (No Load)	–	45	90	ps

Operating Conditions (I-Grade and VDD=3.3V)

Unless otherwise stated VDD= 3.3V+/- 10%, CL=15pF and Ambient Temperature range -40 to +85°C

Description	Symbol	Condition	Min	Typ	Max	Unit
Operating Voltage	VDD	VDD+/-10%	2.97	3.3	3.63	V
Operating Temperature	TA	Ambient Temperature	-40	–	85	°C
Input Capacitance	VIH	Pins 1 and 2	–	6	8	pF
Output Capacitance	COUT	Pins 3, 5, 7 and 8	–	4	6	pF
Load Capacitance	CL	Pins 3, 5, 7 and 8	–	–	25	pF

DC Electrical Characteristics (I-Grade and VDD=3.3V)

Unless otherwise stated VDD= 3.3V+/- 10%, CL=15pF and Ambient Temperature range -40 to +85°C

Description	Symbol	Condition	Min	Typ	Max	Unit
Input LOW Voltage	VINL	CLKIN and OE	–	–	0.8	V
Input HIGH Voltage	VINH	CLKIN and OE	2.0	–	VDD+0.3	V
Input LOW Current	IINL	0 < VIN < 0.8V	-6	+/-3	6	µA
Input HIGH Current	IINH	2.4V < VIN < VDD	-6	+/-3	6	µA
Output Low Voltage	VOL	IoL=24mA	–	–	0.80	V
		IoL=12mA	–	–	0.55	V
Output High Voltage	VOH	IoH=-24mA	2.0	–	–	V
		IoH=-12mA	2.4	–	–	V
Power Supply Current	IDD1	CLKIN=33MHz CL=0 (No load at outputs)	–	8	11	mA
Power Supply Current	IDD2	CLKIN=66MHz CL=0 (No load at outputs)	–	9	13	mA
Power Supply Current	IDD3	CLKIN=133MHz CL=0 (No load at outputs)	–	14	20	mA

Switching Electrical Characteristics (I-Grade and VDD=3.3V)

Unless otherwise stated VDD= 3.3V+/- 10%, CL=15pF and Ambient Temperature range -40 to +85°C

Description	Symbol	Condition	Min	Typ	Max	Unit
Output Frequency Range	FOUT	CL=25pf	0	–	160	MHz
Input Duty Cycle	DC1	Measured at VDD/2	20	50	80	%
Output Duty Cycle	DC2	CL=15pF, Fout=66 MHz Measured at VDD/2	45	50	55	%
Output Duty Cycle	DC3	CL=15pF, Fout=133 MHz Measured at VDD/2	45	50	55	%

Switching Electrical Characteristics (I-Grade and VDD=3.3V – Cont.)

Unless otherwise stated VDD= 3.3V+/- 10%, CL=15pF and Ambient Temperature range -40 to +85°C

Output Fall Time	tf	CL=25pF, measured at 0.8V to 2.0V	–	–	1.6	ns
CLKIN High or Low Time	tHL	CLKIN=66MHz, CL=15pF	5	–	–	ns
		CLKIN=140MHz, CL=15pF	2	–	–	ns
Output to Output Skew	SKW1	Measured at VDD/2 and Outputs are equally loaded	–	50	100	ps
Part to Part Skew	SKW2	Measured at VDD/2 and Outputs are equally loaded	–	90	200	ps
Propagation Delay Time	PDT	Measured at VDD/2 from CLKIN to Output Clock rising edge and Outputs are equally loaded	–	3.2	4.0	ns
Cycle-to-Cycle Jitter	CCJ1	CLKIN=66MHz and CL=0 (No Load)	–	70	140	ps
Cycle-to-Cycle Jitter	CCJ2	CLKIN=133MHz and CL=0 (No Load)	–	50	100	ps

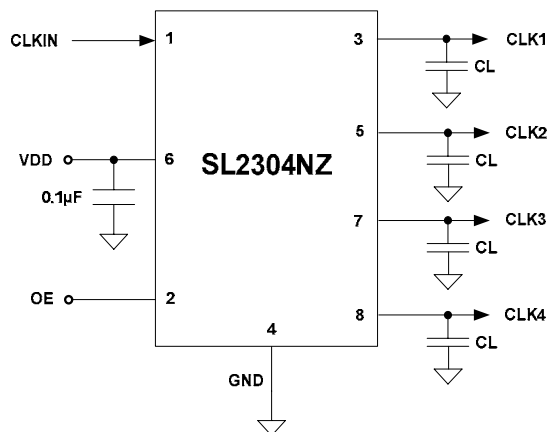
External Components & Design Considerations
Typical Application Schematic

Comments and Recommendations

Decoupling Capacitor: A decoupling capacitor of 0.1µF must be used between VDD and VSS pins. Place the capacitor on the component side of the PCB as close to the VDD pin as possible. The PCB trace to the VDD pin and to the GND via should be kept as short as possible. Do not use vias between the decoupling capacitor and the VDD pin.

Series Termination Resistor: A series termination resistor is recommended if the distance between the output clocks and the load is over 1 ½ inch. Place the series termination resistors as close to the clock outputs as possible.

Package Outline and Package Dimensions

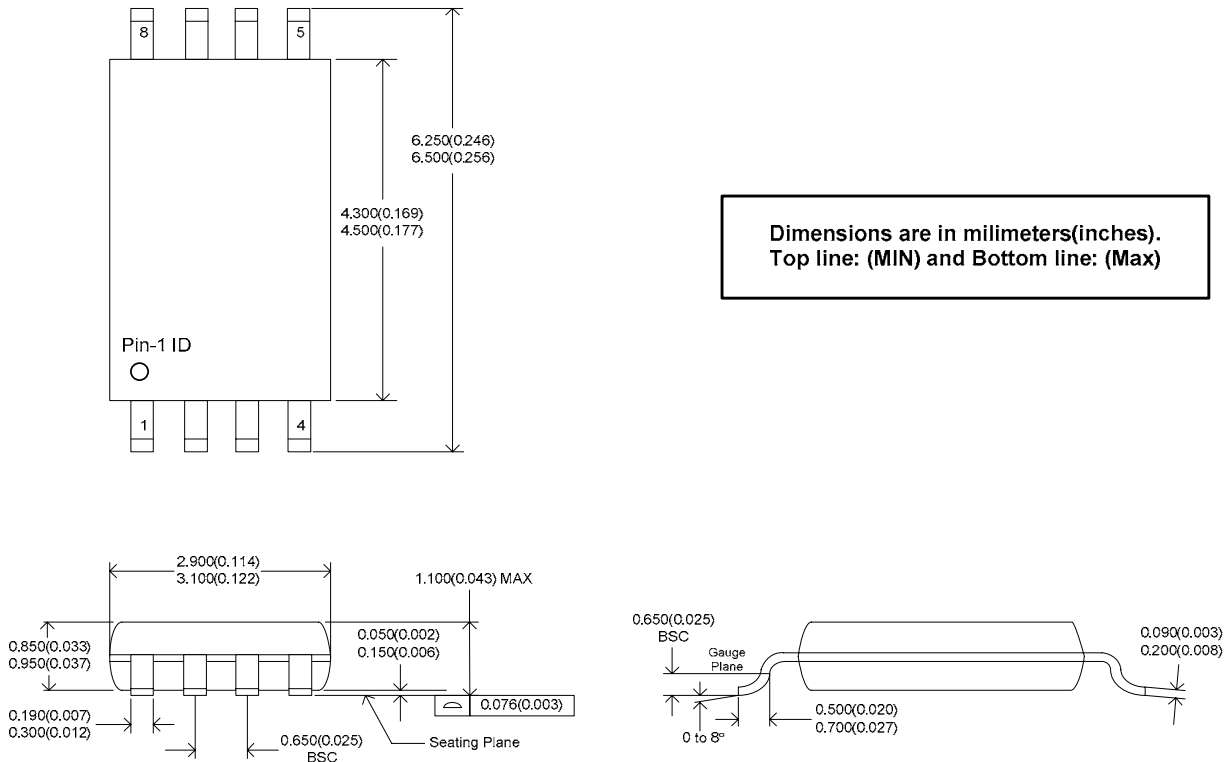
8-Pin TSSOP (4.4 mm)



Thermal Characteristics

Parameter	Symbol	Condition	Min	Typ	Max	Unit
Thermal Resistance Junction to Ambient	θ_{JA}	Still air	-	110	-	$^{\circ}\text{C}/\text{W}$
	θ_{JA}	1m/s air flow	-	100	-	$^{\circ}\text{C}/\text{W}$
	θ_{JA}	3m/s air flow	-	80	-	$^{\circ}\text{C}/\text{W}$
Thermal Resistance Junction to Case	θ_{JC}	Independent of air flow	-	35	-	$^{\circ}\text{C}/\text{W}$

Ordering Information ^[3]

Ordering Number	Marking	Shipping Package	Package	Temperature
SL2304NZZC-1	SL2304NZZC-1	Tube	8-pin TSSOP	0 to 70°C
SL2304NZZC-1T	SL2304NZZC-1	Tape and Reel	8-pin TSSOP	0 to 70°C
SL2304NZZI-1	SL2304NZZI-1	Tube	8-pin TSSOP	-40 to 85°C
SL2304NZZI-1T	SL2304NZZI-1	Tape and Reel	8-pin TSSOP	-40 to 85°C
SL2304NZZC-1Z	SL2304NZZC-1Z	Tube	8-pin TSSOP	0 to 70°C
SL2304NZZC-1ZT	SL2304NZZC-1Z	Tape and Reel	8-pin TSSOP	0 to 70°C
SL2304NZZI-1Z	SL2304NZZI-1Z	Tube	8-pin TSSOP	-40 to 85°C
SL2304NZZI-1ZT	SL2304NZZI-1Z	Tape and Reel	8-pin TSSOP	-40 to 85°C

Notes:

3. The SL2304NZ products are RoHS compliant.

While SLI has reviewed all information herein for accuracy and reliability, Spectra Linear Inc. assumes no responsibility for the use of any circuitry or for the infringement of any patents or other rights of third parties which would result from each use. This product is intended for use in normal commercial applications and is not warranted not is it intended for use in life support, critical medical instruments, or any other application requiring extended temperature range, high reliability, or any other extraordinary environmental requirements unless pursuant to additional processing by Spectra Linear Inc., and an expressed written agreement by Spectra Linear Inc. Spectra Linear Inc. reserves the right to change any circuitry or specification without notice.