

# 3-Axis Digital Compass Module HMC6343

Advanced Information

The Honeywell HMC6343 is a fully integrated compass module that combines 3-axis magneto-resistive sensors and 3-axis MEMS accelerometers with the required analog and digital support circuits, and algorithms for heading computation. By combining the sensor elements, processing electronics, and firmware in to a 9.0mm by 9.0mm by 1.9mm LCC package, Honeywell offers a complete, ready to use tilt-compensated electronic compass. This provides design engineers with the simplest solution to integrate high volume, cost effective compasses into wireless phones, consumer electronics, vehicle compassing, and antenna positioning.

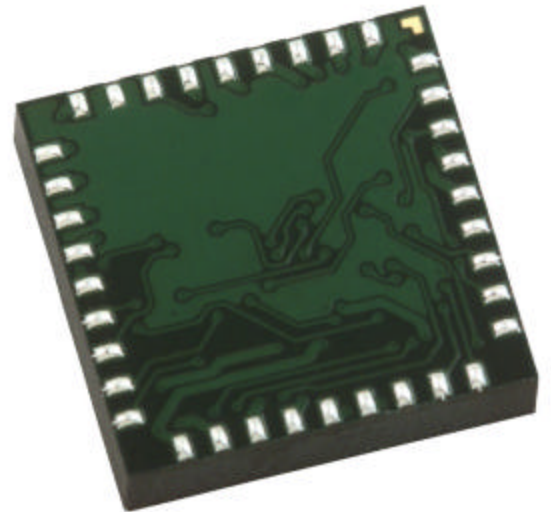

The HMC6343 utilizes Honeywell's Anisotropic Magnetoresistive (AMR) technology that provides advantages over other magnetic sensor technologies. The sensors feature precision sensitivity and linearity, solid-state construction with very low cross-axis sensitivity designed to measure both direction and magnitude of Earth's magnetic fields. Honeywell's Magnetic Sensors are among the most sensitive and reliable low-field sensors in the industry.

Honeywell continues to maintain product excellence and performance by introducing innovative solid-state magnetic sensor solutions. These are highly reliable, top performance products that are delivered when promised. Honeywell's magnetic sensor solutions provide real solutions you can count on.

## FEATURES

## BENEFITS

- |   |  |
|---|--|
| ▶ Compass with Heading Output   | ▶ A Complete Compass. Everything is Done.  |
| ▶ 3-Axis MR Sensors and Accelerometers plus Electronics in a Single Package | ▶ A Complete Digital Solution with Heading/Tilt Outputs and Hard Iron Calibration. Serial Data Interface for Heading Output. |
| ▶ 9 x 9 x 1.9mm LCC Surface Mount Package                                   | ▶ Small Size, Easy to Assemble and Compatible with High Speed SMT Assembly   |
| ▶ Low Voltage Operations (2.7 to 3.6V)                                      | ▶ Compatible for Battery Powered Applications  |
| ▶ Digital Serial Data Interface   | ▶ I <sup>2</sup> C Interface, Easy to Use 2-Wire Communication   |
| ▶ Moderate Precision Outputs  | ▶ +/-2° Heading Accuracy with +/-1° Pitch and Roll Accuracy  |
| ▶ Lead Free Package Construction  | ▶ Complies with RoHS Environmental Standards   |

# HMC6343

## SPECIFICATIONS

Characteristics	Conditions*	Min	Typ	Max	Units
-----------------	-------------	-----	-----	-----	-------

### Power Supply

Supply Voltage	VDD Referenced to GND	2.7	3.3	3.6	Volts
Current	All VDD pins connected together	3.5	4.5	5.5	mA
	Run Mode (10Hz Output)				
	Standby Mode				
	Sleep mode		10		μA

### Compass Function

Field Range	total applied magnetic field		±1	±6	gauss
Heading Accuracy	At Level		2.0	3.0	± deg RMS
	±15° tilt		3.0		
	±60° tilt		4.0		
Heading Resolution	Output Data		0.1		degrees
Update Rate	Run Mode (1, 5, 10Hz)	1	5	10	Hz
Tilt Range	From Horizontal		±80		degrees
Tilt Accuracy	0° to ±15°		±1		degrees
	±15° to ±60°		±2		
Tilt Resolution	Output Data		0.1		degrees

### Offset Straps

Resistance	Measured from OFF+ to OFF-	5	8	11	ohms
Offset Constant	DC Current Field applied in sensitive direction		10		mA/gauss
Resistance Tempco	T <sub>A</sub> =-40 to 125°C	1800	2700	4500	

### General

Operating Temperature	Ambient	-40		80	°C
Storage Temperature	Ambient, unbiased	-55		125	°C
Weight			0.32		grams
ESD Voltage				400	V
MSL	Moisture Sensitivity Level	3			-

\* Tested at 25°C except stated otherwise.

# HMC6343

## FUNCTIONAL DIAGRAM

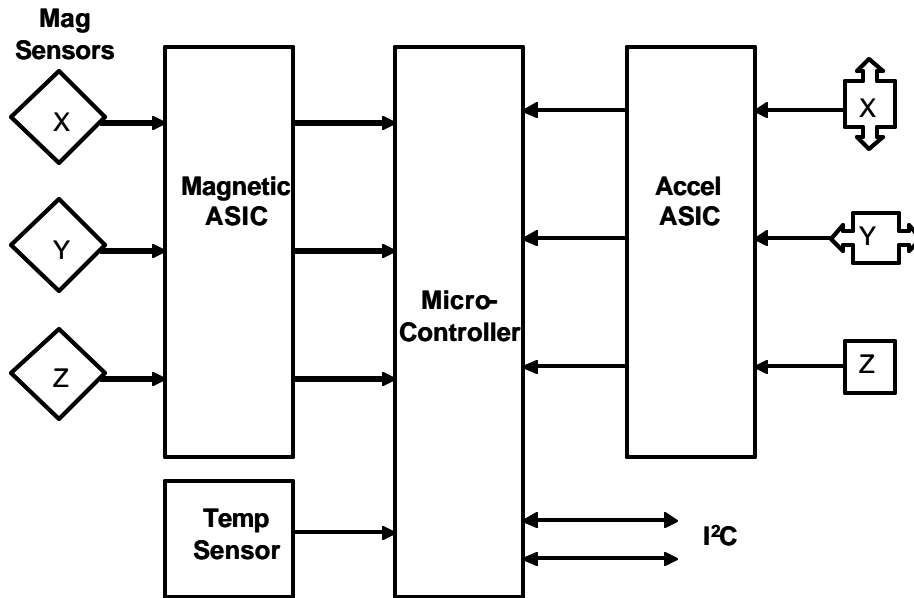

## PIN CONFIGURATIONS

Pin Number	Description	Pin Number	Description
1	RX	19	Y OFF-
2	NC	20	Y OFF+
3	VDD1	21	VDD2
4	NC	22	CS
5	NC	23	X OFF-
6	NC	24	X OFF+
7	NC	25	GND2
8	NC	26	NC
9	NC	27	NC
10	VDD4	28	NC
11	VDD3	29	GND1
12	NC	30	NC
13	NC	31	NC
14	NC	32	SCK/SCL
15	Z OFF-	33	TX
16	Z OFF+	34	SDO
17	NC	35	CS_CTRL
18	NC	36	SDA

# HMC6343

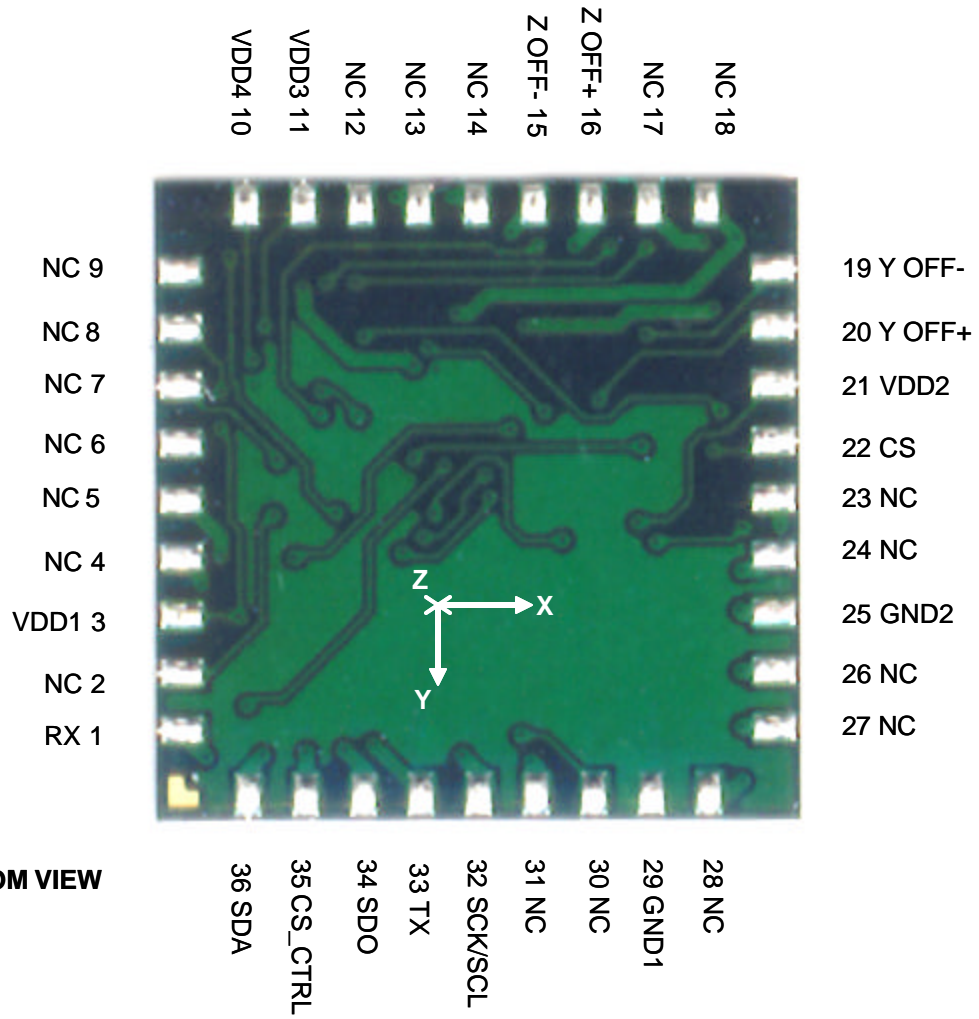

**BOTTOM VIEW**

# HMC6343

## PACKAGE OUTLINES

PACKAGE DRAWING HMC6343 (32-PIN LPCC, dimensions in millimeters)

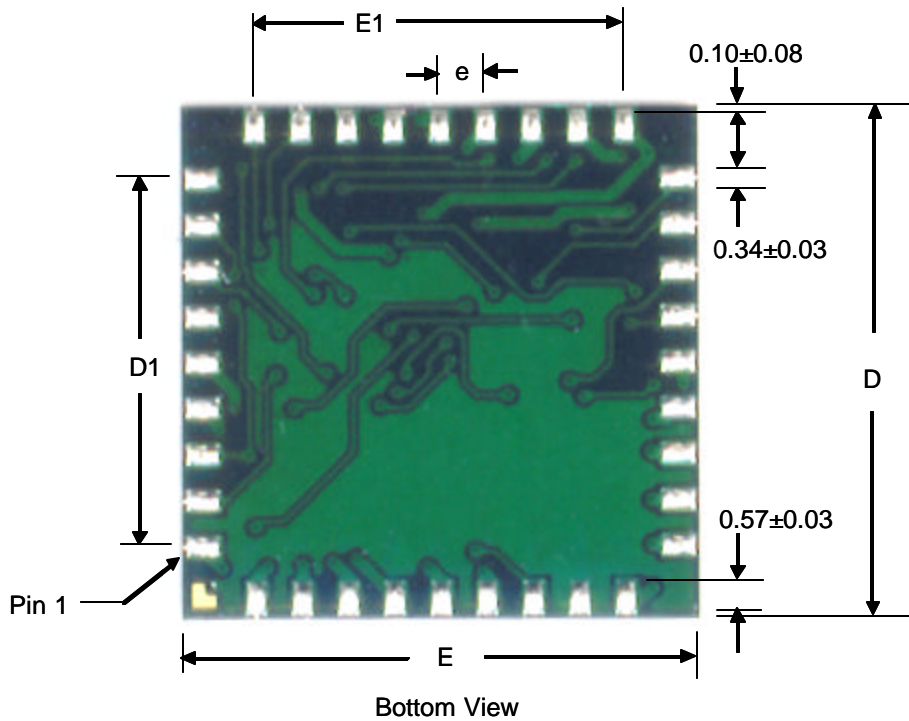

Dimensions (mm)	Minimum	Nominal	Maximum
A (height)	1.73	1.87	2.02
D	-	9.00 BSC	-
D1	-	6.40 BSC	-
E	-	9.00 BSC	-
E1	-	6.40 BSC	-
e	-	0.8 Basic	-

## MOUNTING CONSIDERATIONS

The following is the recommend printed circuit board (PCB) footprint for the HMC6343. All dimensions are nominal and in millimeters.

### Stencil Design and Solder Paste

A 4 mil stencil and 100% paste coverage is recommended for the electrical contact pads. The HMC6343 has been tested successfully with no-clean solder paste.

### Pick and Place

Placement is machine dependant and no restrictions are recommended, and have be tested with mechanical centering. Placement force should be equivalent 1206 SMT resistors and enough force should be used to squeeze the paste out from the package/contact pad overlap and to keep the package pin contacts vertical.

# HMC6343

## BASIC DEVICE OPERATION

The Honeywell HMC6343 magnetoresistive sensor circuit is a trio of magnetic sensors, accelerometers, and analog support circuits to measure magnetic fields. Additionally a microcontroller is integrated for computation of direction and calibration. With power supply applied, the sensor converts any incident magnetic field in the sensitive axis direction to a differential voltage output. In addition to the bridge circuit, the sensors have on-chip magnetically coupled offset straps for incident field adjustment.

## BASIC SCHEMATIC INTERFACE

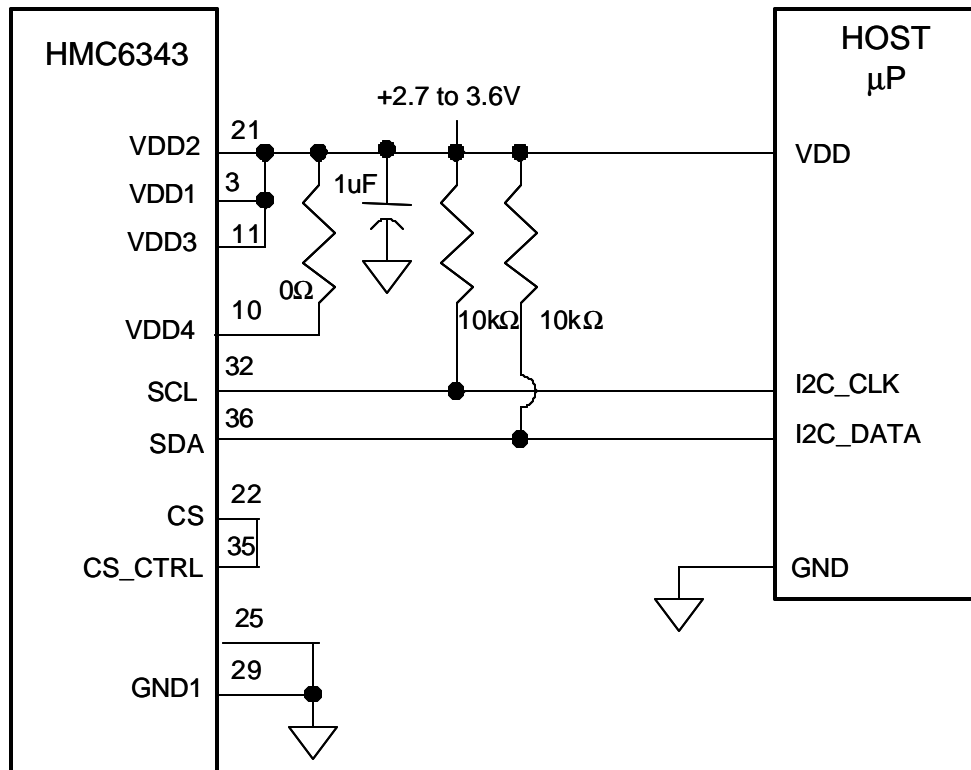

### Offset Straps

The three offset straps have a spiral of metallization that couples in the sensor element's sensitive axis. The straps will easily handle currents to buck or boost fields through the  $\pm 6$  gauss linear measurement range, but designers should note the extreme thermal heating on the die when doing so.

With most applications, the offset strap is not utilized and can be ignored. Designers can leave one or both strap connections (Off- and Off+) open circuited, or ground one connection node.

### Operational Modes

The HMC6343 has three operational modes; Sleep, Standby, and Run. Sleep mode is defined as having the analog circuitry powered off, and has the lowest power consumption while power is applied to the VDD pins. Standby mode has the HMC6343 fully powered, but with no measurements performed and the processor is waiting for commands to perform. Run mode is fully engaged in continuous measurements at the set rate, and ready to receive further commands. The operational mode settings are stored in EEPROM register 0x04, and shown further the HMC6343 protocol definition.

# HMC6343

## Mounting Orientations

The HMC6343 provides for three standard mounting orientations, with a flat horizontal orientation the factory set default. For vertical mounting, there are two upright orientations with either the X-axis or the Z-axis designated as the forward reference directions. To change the forward reference direction, send the appropriate command byte (0x72, 0x73, or 0x74) for level or upright orientations, and reset the processor (or cycle power). To enjoy other orientations, you can add or subtract 90 degree increments of deviation angle as required from the three choices. The figure below shows pictorially the orientations.

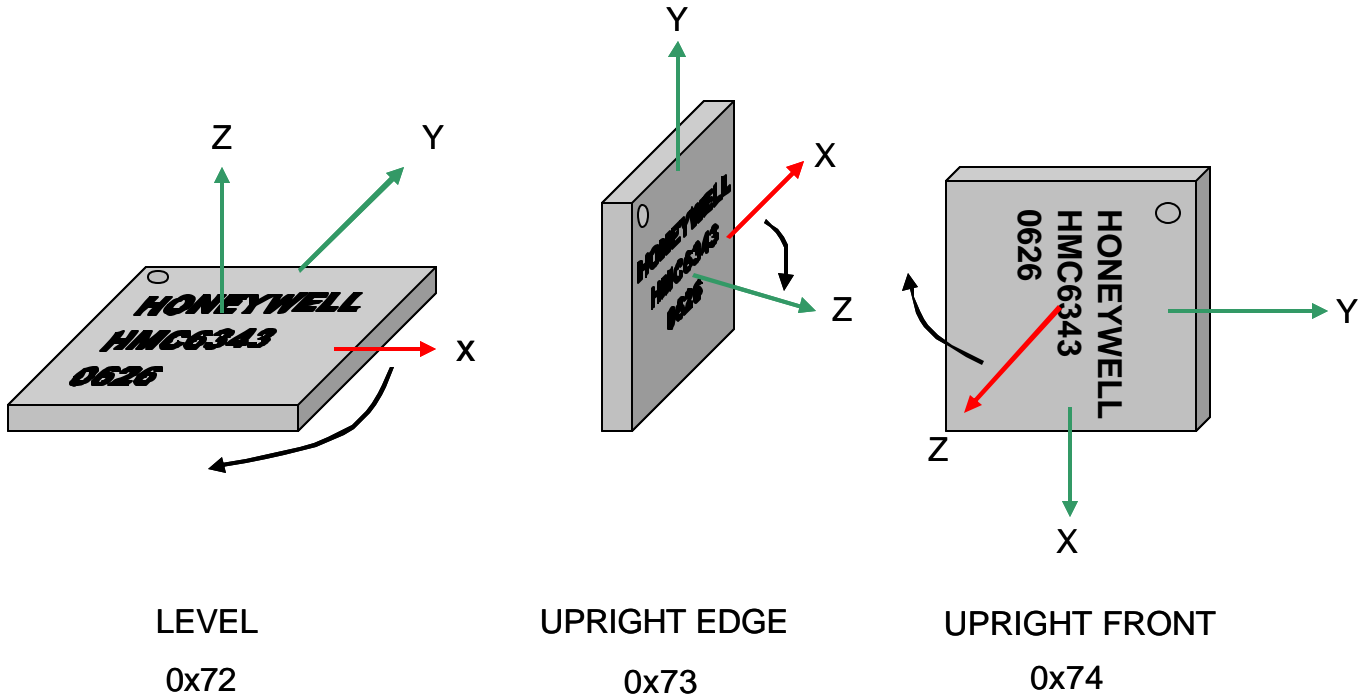

## HMC6343 ORIENTATIONS

Red Arrow is the Forward Direction

## I<sup>2</sup>C COMMUNICATION PROTOCOL

The HMC6343 communicates via a two-wire I<sup>2</sup>C bus system as a slave device. The HMC6343 uses a layered protocol with the interface protocol defined by the I<sup>2</sup>C bus specification, and the lower command protocol defined by Honeywell. The data rate is the standard-mode 100kbps rate as defined in the I<sup>2</sup>C Bus Specification 2.1. The bus bit format is an 8-bit Data/Address send and a 1-bit acknowledge bit. The format of the data bytes (payload) shall be case sensitive ASCII characters or binary data to the HMC6343 slave, and binary data returned. Negative binary values will be in two's complement form. The default (factory) HMC6343 7-bit slave address is 0x32 for write operations, or 0x33 for read operations.

The HMC6343 Serial Clock (SCL) and Serial Data (SDA) lines do not have internal pull-up resistors, and require resistive pull-ups (Rp) between the master device (usually a host microprocessor) and the HMC6343. Pull-up resistance values of about 10k ohms are recommended with a nominal 3.3-volt supply voltage. Other values may be used as defined in the I<sup>2</sup>C Bus Specification 2.1.

The SCL and SDA lines in this bus specification can be connected to a host of devices. The bus can be a single master to multiple slaves, or it can be a multiple master configuration. All data transfers are initiated by the master device which is responsible for generating the clock signal, and the data transfers are 8 bit long. All devices are addressed by I<sup>2</sup>C's unique 7 bit address. After each 8-bit transfer, the master device generates a 9<sup>th</sup> clock pulse, and releases the SDA line. The receiving device (addressed slave) will pull the SDA line low to acknowledge (ACK) the successful transfer or leave the SDA high to negative acknowledge (NACK).

## HMC6343

Per the I<sup>2</sup>C spec, all transitions in the SDA line must occur when SCL is low. This requirement leads to two unique conditions on the bus associated with the SDA transitions when SCL is high. Master device pulling the SDA line low while the SCL line is high indicates the Start (S) condition, and the Stop (P) condition is when the SDA line is pulled high while the SCL line is high. The I<sup>2</sup>C protocol also allows for the Restart condition in which the master device issues a second start condition without issuing a stop.

All bus transactions begin with the master device issuing the start sequence followed by the slave address byte. The address byte contains the slave address; the upper 7 bits (bits7-1), and the Least Significant bit (LSb). The LSb of the address byte designates if the operation is a read (LSb=1) or a write (LSb=0). At the 9<sup>th</sup> clock pulse, the receiving slave device will issue the ACK (or NACK). Following these bus events, the master will send data bytes for a write operation, or the slave will clock out data with a read operation. All bus transactions are terminated with the master issuing a stop sequence.

I<sup>2</sup>C bus control can be implemented with either hardware logic or in software. Typical hardware designs will release the SDA and SCL lines as appropriate to allow the slave device to manipulate these lines. In a software implementation, care must be taken to perform these tasks in code.

### I<sup>2</sup>C Slave Address

The I<sup>2</sup>C slave address byte consists of the 7 most significant bits with the least significant bit zero filled. As described earlier, the default (factory) value is 0x32 and the legal I<sup>2</sup>C bounded values are between 0x10 and 0xF6. This slave address is in EEPROM address 0x00. Users can change the slave address by writing to this location. Any address updates will become effective after the next power up or after a reset command.

### Software Version

This EEPROM software version number byte contains the binary value of the programmed software. Values of 0x05 and beyond are considered production software.

### Deviation Angle Correction

Typically the HMC6343 X-axis (or Z-axis) is designated the forward direction of the compass, and is placed mechanically towards the forward direction of the end user product. The deviation angle is used to correct for mechanical angle errors in package orientation by adding the deviation angle to the internal compass heading before the result is placed as the computed heading. Two EEPROM Bytes are used to store the deviation angle, and the binary value is in tenths of a degree and in two's complement form for a  $\pm 1800$  representation. The deviation angle MSB is located in EEPROM register 0x0B and the LSB in 0x0A.

### Variation Angle Correction

The variation angle or declination angle of the HMC6343 is the number of degree that must be added to the internal compass heading to convert the magnetic north reference direction to the geographic (true) north reference direction. This angle information is provided to the HMC6343 from external latitude and longitude data processed through a World Magnetic Model equation to compute variation angle, or by lookup table. Two EEPROM Bytes are used to store the variation angle, and the binary value is in tenths of a degree and in two's complement form for a  $\pm 1800$  representation. The deviation angle MSB is located in EEPROM register 0x0D and the LSB in 0x0C.

### Magnetometer Offsets

The Magnetometer Offset bytes are the values stored after the completion of the last factory or user hard-iron calibration routine. Additional value changes are possible, but will be overwritten when the next calibration routine is completed. Note that these offset values are added to the sensor offset values computed by the set/reset routine to convert the raw magnetometer data to the compensated magnetometer data. These values are written into EEPROM addresses 0x0E to 0x13 and loaded to RAM on the power up.



# HMC6343

## Heading Filter

This allows for an Infinite Impulse Response (IIR) filter to be employed on current and previous heading data outputs. Typical values are 0 to 15 with a factory default of zero. The filter is only applied in run mode where a continuous stream of data is present. At the 5Hz default update rate, a filter value of 4 would weight the latest heading with the previous four headings of regressive weightings for a second's worth of filtering.

## EEPROM Registers

The HMC6343 contains EEPROM non-volatile memory locations (registers) to store useful compass data for processor routines. The following Table shows the register locations, content, description, and factory shipped defaults.

**Table 1 – EEPROM Registers**

EEPROM Location	Content	Description	Factory Default
0x00	Slave Address	I2C Slave Address	0x32
0x01	Reserved		
0x02	S/W_Version	Software Version Number	
0x03	Reserved		
0x04	OP_Mode1	Operational Mode Register 1	0x11
0x05	OP_Mode2	Operational Mode Register 2	0x01
0x06	S/N LSB	Device Serial Number	
0x07	S/N MSB	Device Serial Number	
0x08	Date Code: YY	Package Date Code: Last Two Digits of the Year	Year
0x09	Date Code: WW	Package Date Code: Fiscal Week	Week
0x0A	Deviation LSB	Deviation Angle ( $\pm 1800$ ) in tenths of a degree	0x00
0x0B	Deviation MSB	Deviation Angle ( $\pm 1800$ ) in tenths of a degree	0x00
0x0C	Variation LSB	Variation Angle ( $\pm 1800$ ) in tenths of a degree	0x00
0x0D	Variation MSB	Variation Angle ( $\pm 1800$ ) in tenths of a degree	0x00
0x0E	X_Offset LSB	Hard-Iron Calibration Offset for the X-axis	0x00
0x0F	X_Offset MSB	Hard-Iron Calibration Offset for the X-axis	0x00
0x10	Y_Offset LSB	Hard-Iron Calibration Offset for the Y-axis	0x00
0x11	Y_Offset MSB	Hard-Iron Calibration Offset for the Y-axis	0x00
0x12	Z_Offset LSB	Hard-Iron Calibration Offset for the Z-axis	0x00
0x13	Z_Offset MSB	Hard-Iron Calibration Offset for the Z-axis	0x00
0x14	Filter LSB	Heading IIR Filter (0x00 to 0x0F typical)	0x00
0x15	Filter MSB	Heading IIR Filter (set at zero)	0x00

# HMC6343

## Command Protocol

The command protocol defines the content of the data (payload) bytes of I<sup>2</sup>C protocol sent by the master, and the slave device (HMC6343).

After the master device sends the 7-bit slave address, the 1-bit Read/Write, and gets the 1-bit slave device acknowledge bit returned; the next one to three sent data bytes are defined as the input command and argument bytes. To conserve data traffic, all response data (Reads) will be context sensitive to the last command (Write) sent. All write commands shall have the address byte least significant bit cleared (factory default 0x32). These commands then follow with the command byte and command specific binary formatted argument bytes in the general form of:

(Command Byte) (Argument Binary MS Byte) (Argument Binary LS Byte)

The slave (HMC6343) shall provide the acknowledge bits between each data byte per the I<sup>2</sup>C protocol. Response byte reads are done by sending the address byte (factory default 0x33) with the least significant bit set, and then clocking back response bytes, last command dependant. Table 2 shows the HMC6343 command and response data flow.

**Table 2 – HMC6343 Interface Commands/Responses**

Command Byte (hex)	Argument 1 Byte (Binary)	Argument 2 Byte (Binary)	Response Bytes (Binary)	Command Description
(0x40)			MSB/LSB Data (6 Bytes)	Post Accel Data. AxMSB, AxLSB, AyMSB, AyLSB, AzMSB, AzLSB
(0x45)			MSB/LSB Data (6 Bytes)	Post Mag Data. MxMSB, MxLSB, MyMSB, MyLSB, MzMSB, MzLSB
(0x50)			MSB/LSB Data (6 Bytes)	Post Heading Data. HeadMSB, HeadLSB, PitchMSB, PitchLSB, RollMSB, RollLSB
(0x55)			MSB/LSB Data (6 Bytes)	Post Tilt Data. PitchMSB, PitchLSB, RollMSB, RollLSB, TempMSB, TempLSB
(0x70)				Enter User Calibration Mode
(0x72)				Level Orientation (X=forward, +Z=up) (default)
(0x73)				Upright Sideways Orientation (X=forward, Y=up)
(0x74)				Upright Flat Front Orientation (Z=forward, -X=up)
(0x75)				Enter Run Mode (from Standby Mode)
(0x76)				Enter Standby Mode (from Run Mode)
(0x7F)				Exit User Calibration Mode
(0x82)				Reset the Processor
(0x83)				Enter Sleep Mode (from Run Mode)
(0x84)				Exit Sleep Mode (to Standby Mode)
(0xE1)	EEPROM Address		Data (1 Byte)	Read from EEPROM
(0xF1)	EEPROM Address	Data		Write to EEPROM

# HMC6343

## Timing

Upon power application to the HMC6343, wait nominally 5 milli-seconds before sending the first I2C command (typically a 0x32 byte followed by a 0x50 byte for the usual heading/pitch/roll). Depending on the command sent, a delay time should be inserted before clocking out the response bytes (send 0x33, clock back response bytes). The following table indicates the response delay times for various commands.

**Table 3 – HMC6343 Command to Response Delay Times**

Prior Command (hex)	Commanded Action	Response Bytes & Description	Response/Delay Time (milli-seconds)
Power Applied	VDD1-3 low to high	No Response Data	5 nominally
0x40	Post Accel Data.	6 binary data Bytes. AxMSB, AxLSB, AyMSB, AyLSB, AzMSB, AzLSB	1
0x45	Post Mag Data.	6 binary data Bytes.. MxMSB, MxLSB, MyMSB, MyLSB, MzMSB, MzLSB	1
0x50	Post Heading Data.	6 binary data Bytes. HeadMSB, HeadLSB, PitchMSB, PitchLSB, RollMSB, RollLSB	1
0x55	Post Tilt Data.	6 binary data Bytes. PitchMSB, PitchLSB, RollMSB, RollLSB, TempMSB, TempLSB	1
0x70	Enter User Calibration Mode	No Response Data	0.3
0x72	Level Orientation	(X=forward, +Z=up) (default) No Response Data	0.3
0x73	Upright Sideways Orientation	(X=forward, Y=up) No Response Data	0.3
0x74	Upright Flat Front Orientation	(Z=forward, -X=up) No Response Data	0.3
0x75	Enter Run Mode	No Response Data	0.3
0x76	Enter Standby Mode	No Response Data	0.3
0x7F	Exit User Calibration Mode	No Response Data	3
0x82	Reset the Processor	No Response Data	0.3
0x83	Enter Sleep Mode	No Response Data	1
0x84	Exit Sleep Mode	No Response Data	20
0xE1	Read from EEPROM	1 binary data Byte	10
0xF1	Write to EEPROM	No Response Data. Data Settling Time	10

# HMC6343

## Operational Mode Registers

EEPROM registers 0x04 and 0x05 contain Bytes that are read for operational mode status and for setting the Run Mode measurement rate. The tables below describe the register contents and interpretation. It is recommended that Operational Mode Register 1 be read only, and register 2 written only to change update rate.

**Table 4 – Operational Mode Register 1 (EEPROM 0x04)**

OM1_7	OM1_6	OM1_5	OM1_4	OM1_3	OM1_2	OM1_1	OM1_0
Comp(0)	Cal(0)	Filter(0)	Run(1)	Stdby(0)	UF(0)	UE(0)	Level(1)

**Table 5 – Operational Mode Register 1 Bit Designations**

Location	Name	Description
OM1_7	Comp	Calculating compass data if set. (read only)
OM1_6	Cal	Calculating calibration offsets if set. (read only)
OM1_5	Filter	IIR Heading Filter used if set.
OM1_4	Run	Run Mode if set.
OM1_3	Stdby	Standby Mode if set.
OM1_2	UF	Upright Front Orientation if set.
OM1_1	UE	Upright Edge Orientation if set.
OM1_0	Level	Level Orientation if set

**Table 6 – Operational Mode Register 2 (EEPROM 0x05)**

OM2_7	OM2_6	OM2_5	OM2_4	OM2_3	OM2_2	OM2_1	OM2_0
(0)	(0)	(0)	(0)	(0)	(0)	MR1(0)	MR0(1)

**Table 7 – Operational Mode Register 2 Bit Designations**

Location	Name	Description
OM1_7 to OM2_2	0	These bits must be cleared for correct operation.
OM2_1 to OM2_0	MR1, MR0	Measurement Rate 0,0 = 1Hz 0,1 = 5Hz (default) 1,0 = 10Hz 1,1 = Not Assigned

## User Hard-Iron Calibration

The HMC6343 provides a user calibration routine with the 0x70 command permitting entry into the calibration mode and the 0x7F command to exit the calibration mode. During the calibration procedure, the compass and the platform to which the compass is attached is rotated at a reasonably steady speed through 360 degrees. This process should at least take one minute for best accuracy. For best HMC6343 calibration, the rotation should include as much pitch and roll orientations possible. The calibration time window is recommended to be from 60 seconds up to 3 minutes depending on the end user's platform.

The calibration routine collects these readings to correct for hard-iron distortions of the magnetic field. These hard-iron effects are due to magnetized materials nearby the HMC6343 part that in a fixed position with respect to the end user platform. An example would be the magnetized chassis or engine block of a vehicle in which the compass is mounted onto. Upon exiting the calibration mode, the resulting magnetometer offsets and scaling factors are updated.

# HMC6343

## Example Communication

For basic power up and compassing using the defaults, the following order of operations is recommended:

1. Apply power to the VDD pins (nominally +3.3 volts)
2. Wait at least 5 milli-seconds for device initialization. The HMC6343 is in the default Run Mode.
3. Send 0x32 and 0x50 to command the Heading and Tilt Data to be clocked out next.
4. Wait at least 1 milli-second to allow the HMC6343 to process the command.
5. Send 0x33 and clock back six more response Bytes from the HMC6343. These will be the Heading, Pitch and Roll Byte pairs; binary format in tenths of a degree with 2's complement on pitch and roll angles. (0 to 3600 heading,  $\pm 1800$  pitch, and  $\pm 1800$  roll)
6. Repeat the 0x33 sends and six Byte clock backs every 200 milli-seconds or longer to get fresh data from the default 5Hz update rate.

## ORDERING INFORMATION

Ordering Number	Product
HMC6343	Digital Compass Module

## FIND OUT MORE

For more information on Honeywell's Magnetic Sensors visit us online at [www.magneticsensors.com](http://www.magneticsensors.com) or contact us at 800-323-8295 (763-954-2474 internationally).

The application circuits herein constitute typical usage and interface of Honeywell product. Honeywell does not warranty or assume liability of customer-designed circuits derived from this description or depiction.

Honeywell reserves the right to make changes to improve reliability, function or design. Honeywell does not assume any liability arising out of the application or use of any product or circuit described herein; neither does it convey any license under its patent rights nor the rights of others.

U.S. Patents 4,441,072, 4,533,872, 4,569,742, 4,681,812, 4,847,584 and 6,529,114 apply to the technology described

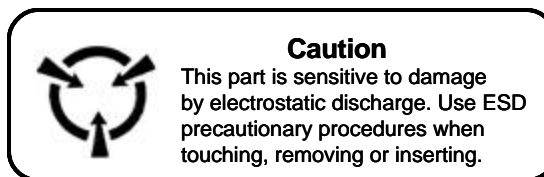

**CAUTION: ESDS CAT. 1A**