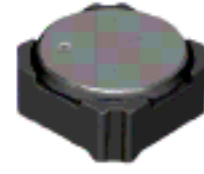
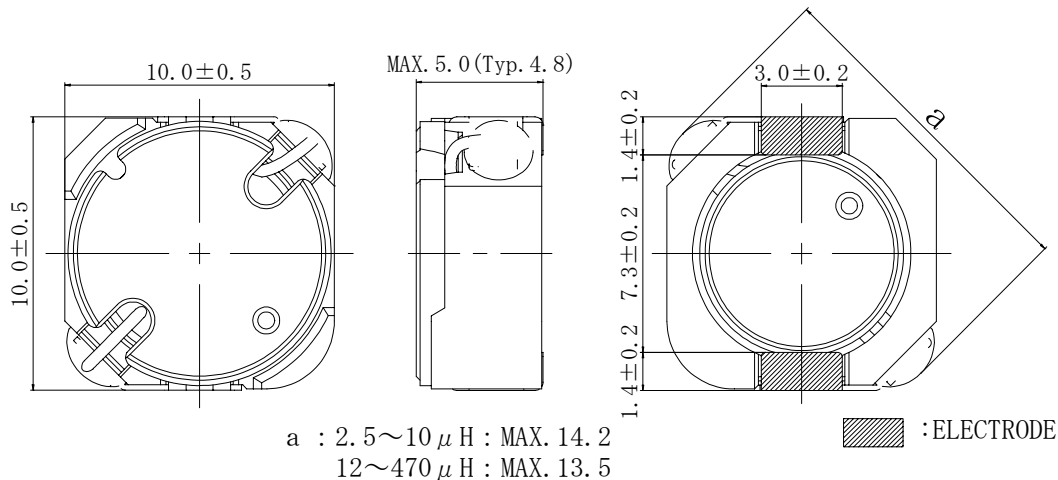
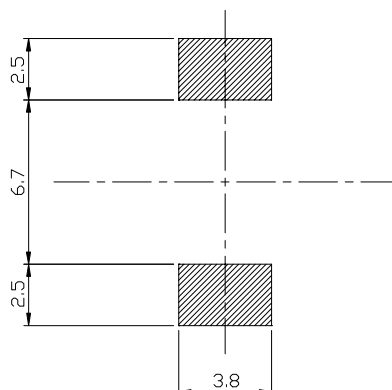

Type: CDRH10D48MN
◆ Product Description

- 10.5×10.5mm Max.(L×W), 5.0 mm Max. Height.
- Inductance Range:2.5~470 μ H
- Rated current range: 0.49~8.9A
- In addition to the standard versions of inductors shown here, custom inductors are available to meet your exact requirements.

◆ Feature

- Magnetically shielded construction.
- Hybrid power inductors use Mn-Zn D.core & Ni-Zn R.core, used as general power inductors.
- Higher saturation current characteristics than that of Ni-Zn inductors.
- Usually used in LCD driver,DSC/DVC,Notebook PC or the other portable equipment,.
- RoHS Compliance.

◆ Dimensions (mm)

◆ Land Pattern (mm)

Type: CDRH10D48MN
◆ Specification

Part Name ※	Stamp	Inductance [Within] 100kHz/1V	D.C.R.(mΩ) Max.(Typ.) (at 20°C)	Saturation Current (A) ※1		Temperature rise current (A)※2
				(at20°C)	(at105°C)	
CDRH10D48MNNP-2R5N□	2R5	2.5 μH±25%	8.8(7)	10.20	7.50	8.90
CDRH10D48MNNP-3R7N□	3R7	3.7 μH±25%	10.0(8)	8.40	6.30	7.00
CDRH10D48MNNP-5R1N□	5R1	5.1 μH±25%	12.5(10)	7.40	5.60	6.30
CDRH10D48MNNP-6R7N□	6R7	6.7 μH±25%	17.5(14)	6.60	5.10	5.50
CDRH10D48MNNP-8R6N□	8R6	8.6 μH±25%	19(15)	5.80	4.40	4.80
CDRH10D48MNNP-100N□	100	10 μH±25%	24(19)	5.10	3.90	4.20
CDRH10D48MNNP-120N□	120	12 μH±25%	33(26)	4.70	3.60	3.50
CDRH10D48MNNP-150N□	150	15 μH±25%	37(29)	4.50	3.40	3.20
CDRH10D48MNNP-180N□	180	18 μH±25%	45(36)	4.10	3.10	2.80
CDRH10D48MNNP-220N□	220	22 μH±25%	49(39)	3.70	2.90	2.60
CDRH10D48MNNP-270N□	270	27 μH±25%	58(46)	3.30	2.60	2.40
CDRH10D48MNNP-330N□	330	33 μH±25%	68(54)	3.10	2.40	2.30
CDRH10D48MNNP-390N□	390	39 μH±25%	89(71)	2.80	2.10	1.90
CDRH10D48MNNP-470N□	470	47 μH±25%	95(76)	2.60	2.00	1.80
CDRH10D48MNNP-560N□	560	56 μH±25%	117(93)	2.40	1.80	1.60
CDRH10D48MNNP-680N□	680	68 μH±25%	130(104)	2.10	1.60	1.50
CDRH10D48MNNP-820N□	820	82 μH±25%	168(134)	1.90	1.50	1.30
CDRH10D48MNNP-100N□	101	100 μH±25%	203(162)	1.70	1.30	1.20
CDRH10D48MNNP-121N□	121	120 μH±25%	230(184)	1.60	1.20	1.10
CDRH10D48MNNP-151N□	151	150 μH±25%	284(227)	1.40	1.10	0.98
CDRH10D48MNNP-181N□	181	180 μH±25%	367(293)	1.30	0.99	0.84
CDRH10D48MNNP-221N□	221	220 μH±25%	448(358)	1.20	0.91	0.75
CDRH10D48MNNP-271N□	271	270 μH±25%	535(428)	1.10	0.83	0.66
CDRH10D48MNNP-331N□	331	330 μH±25%	655(524)	0.96	0.77	0.59
CDRH10D48MNNP-391N□	391	390 μH±25%	790(632)	0.88	0.69	0.53
CDRH10D48MNNP-471N□	471	470 μH±25%	965(772)	0.80	0.62	0.49

※ Description of part name

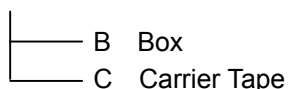
CDRH10D48MNNP-2R5N□



※1. Saturation current: The DC current at which the inductance decreases to 65% of its nominal value.

※2. Temperature rise current: The DC current at which the temperature rise is Δt=40°C. (Ta=20°C).