

TOSHIBA BIPOLAR LINEAR INTEGRATED CIRCUIT SILICON MONOLITHIC

TA8462F/FG

FAN MOTOR DRIVER IC

The TA8462F/FG is a 2 phase half-wave hall motor driver IC. This IC is best suited for the fan motor driving.

The output current of this IC is 1.5 A (peak) and all functions needed for fan motor driving have been incorporated into a 1 chip, enabling it to largely reduce peripheral parts and a space, thus realizing down-sizing.

Further, the TA8462F/FG is provided with the FG output pin (outputs pulses proportional to the motor speed) and the RD output pin (outputs the motor ON / OFF statuses).

FEATURES

- Built-in Automatic Self Rotation Recovery Circuit After Release of Motor Locking.
- Thermal Shutdown Circuit Incorporated.
- Operating Voltage: 4~15 V
- Recommended Operating Voltage: $V_{CC} = 5\text{ V}, 12\text{ V}$
- No V_{CC} -GND Reverse Connection Preventive Diode Required.

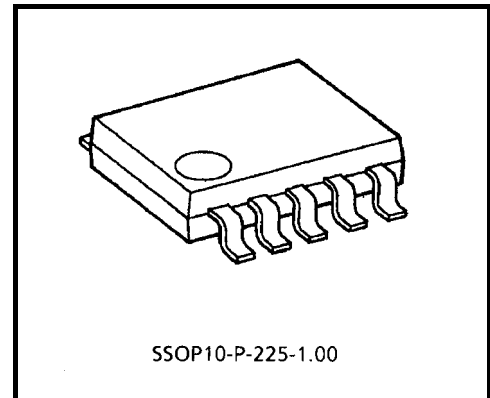

Weight : 0.09 g (Typ.)

The TA8462FG:

The TA8462FG is a Pb-free product.

The following conditions apply to solderability:

*Solderability

1. Use of Sn-37Pb solder bath
 - *solder bath temperature = 230°C
 - *dipping time = 5 seconds
 - *number of times = once
 - *use of R-type flux
2. Use of Sn-3.0Ag-0.5Cu solder bath
 - *solder bath temperature = 245°C
 - *dipping time = 5 seconds
 - *the number of times = once
 - *use of R-type flux

BLOCK DIAGRAM

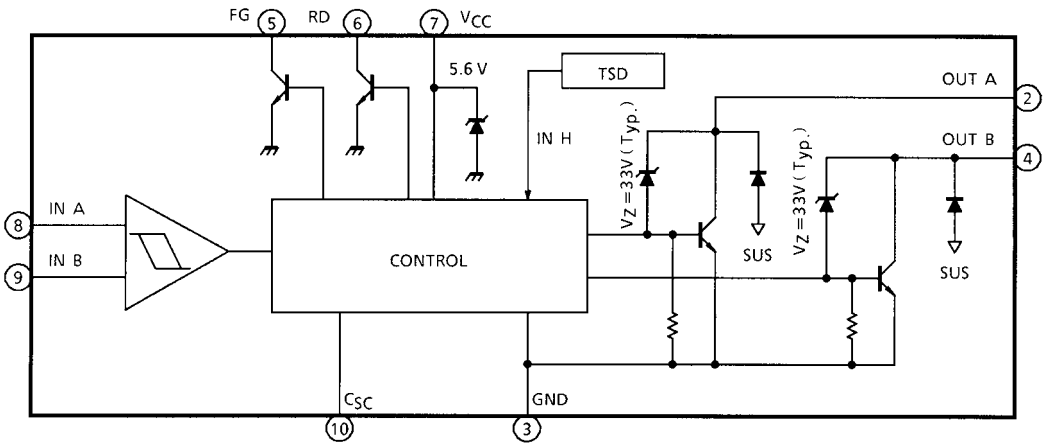

PIN FUNCTION

PIN No.	SYMBOL	FUNCTIONAL DESCRIPTION
1	NC	Non connection
2	OUT A	Output terminal
3	GND	GND terminal
4	OUT B	Output terminal
5	FG	Rotation speed output terminal
6	RD	Rotation detect output terminal
7	V _{CC}	Power voltage supply terminal
8	IN A	Hall input terminal
9	IN B	Hall input terminal
10	C _{SC}	Lock protector time constant determined terminal

- FG and RD outputs

Both the FG and RD outputs are the open collector outputs.

The FG output is pulse proportional to the number of revolutions (the cycle is the same as OUT B) and the RD output is at the GND level (actually, at V_{sat} (RD) level) when the motor is being driven and the RD output at the potential level that is to be applied to the RD terminal as shown in Figure 2 is output when the motor is kept restrained.

- Automatic self rotation recovery circuit

If the rotation of the fan motor is forced to stop by any physical power, the driving coil may be burnt as inducing voltage caused when the motor is running disappears and large current flows to the driving coil.

Therefore, it becomes necessary to provide the fan motor with a circuit to prevent the driving coil from being burned by detecting the forced stop of the motor rotation from the outside by some method and a circuit to automatically rotate the motor when it is released from the restraint.

The TA8462F/FG is an IC that has cleared the above problems by the burning preventive automatic return circuit.

This operation is shown in Figure 1.

The capacitor C_{SC} connected to the C_{SC} terminal is charged by the charging current I_{SL} (6.3 μA Typ.) and its potential rises as shown below :

$$V = \frac{1}{C_{SC}} \int I_{SL} dt$$

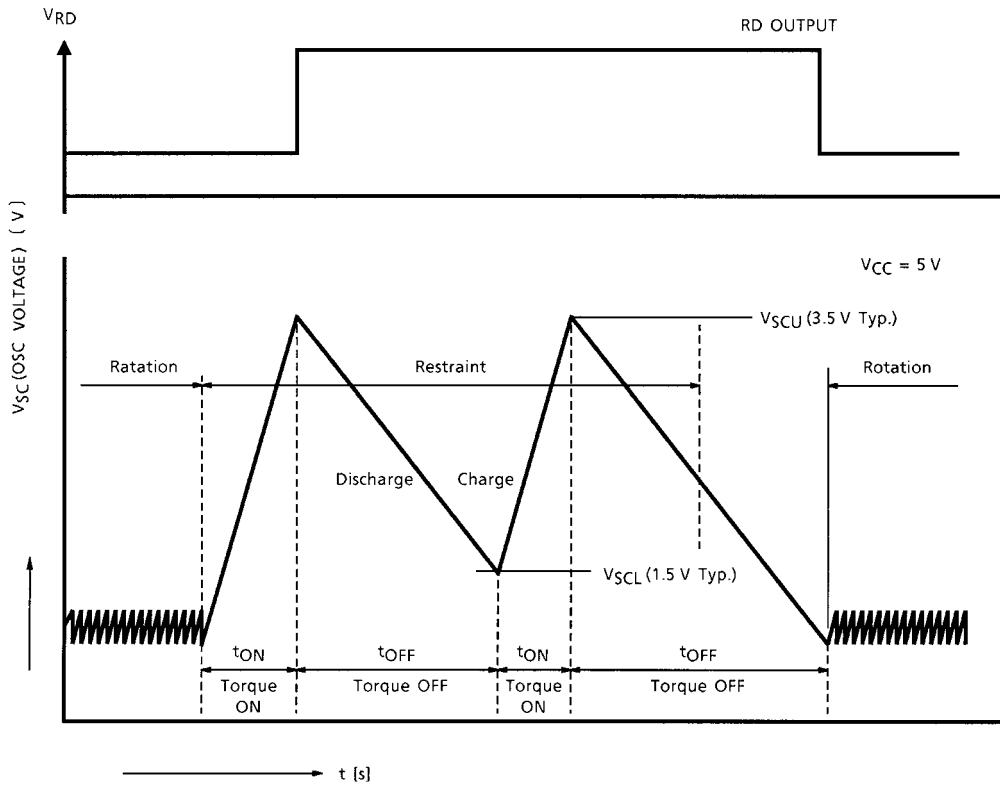

Fig.1 Auto mAtic Self Rotation Recovery Circuit Operation

When the motor is rotating, it is charged and discharged repeatedly by trigger pulse but if the motor rotation is physically restrained, CSC discharge by trigger pulse is stopped and the potential further increases. During this period, current flows continuously to the motor. If VSC (OSC potential) reaches VSCU (3.5 V Typ.), discharge starts slowly and at the same time, the output is turned OFF to cur off current flowing to the motor. When the VSC potential reaches VSCL (1.5 V Typ.), the output is turned ON to allow current flow to the motor and torque is generated.

As long as the motor rotation is kept restrained, this operation is repeated and the output is turned ON / OFF at a ratio of nearly 1 : 5.

By this operation, the motor is heated and cooled and its temperature rise can be suppressed to a certain level. If the motor is released from the above restraint, the motor is started to run again by the generated torque and is continuously rotated by the generated trigger pulse.

ABSOLUTE MAXIMUM RATINGS (Ta = 25°C)

CHARACTERISTIC	SYMBOL	RATING	UNIT
Output Terminal Breakdown Voltage	V _{CER}	35	V
Output Current (PEAK)	I _O (PEAK)	1.5 (Note 1)	A
FG Output Current (PEAK)	I _{FG} (PEAK)	10 (Note 1)	mA
RD Output Current (PEAK)	I _{RD} (PEAK)	10 (Note 1)	mA
Hall Input Voltage	V _{HM}	300 (Note 2)	mV
Power Dissipation	P _D	735 (Note 3)	mW
Operating Temperature	T _{opr}	-30~85	°C
Storage Temperature	T _{stg}	-55~150	°C

Note 1: t = 0.1 s

Note 2: T_j = -25~150°C

Note 3: This value is obtained by 50 × 50 × 1.6 mm PCB mounting occupied in excess of 30% of copper area.

ELECTRICAL CHARACTERISTICS

(Ta = 25°C, V_{CC} = 12 V, R_{VCC} = 200 Ω, C_{SC} = 1.0 μF)

CHARACTERISTIC		SYMBOL	TEST CIR-CUIT	TEST CONDITION	MIN	TYP.	MAX	UNIT	
Supply Current	I _{CC}	—	—	V _{CC} = 5 V, R _{VCC} = 0 Ω Output open	A: ON	—	8.7	13.0	mA
					B: ON	—	7.7	12.0	
				V _{CC} = 12 V R _{VCC} = 200 Ω Output open	A: ON	—	28	35	
					B: ON	—	28	35	
Output Saturation Voltage	V _{SAT}	—	—	I _O = 0.2 A, T _j = 25°C	—	0.8	1.0	V	
				I _O = 1.0 A, T _j = 25°C	—	1.15	1.6		
Output Terminal Clamp Voltage		V _{CER}	—	—	31	—	35	V	
Automatic Self Rotation Recovery Circuit	Charge Current	I _c	—	C _{SC} = GND	3.0	6.2	8.2	μA	
	Discharge Current	I _d	—	C _{SC} = 4 V	0.5	1.15	1.3		
	Output OFF Voltage	V _{SCU}	—	V _{CC} = 5 V	—	3.5	—	V	
	Output ON Voltage	V _{SCL}	—	V _{CC} = 5 V	—	1.5	—		
	Duty	DR	—	I _d / I _c = t _{OFF} / t _{ON}	3	5	8	s	
	ON Time	t _{ON}	—	—	—	0.35	—		
	OFF Time	t _{OFF}	—	—	—	1.75	—		

CHARACTERISTIC		SYMBOL	TEST CIR-CUIT	TEST CONDITION	MIN	TYP.	MAX	UNIT
Hall Amp.	Sensitivity	V_{HS}	—	Include offset / hysteresis	10	—	—	mV
	Hysteresis	V_{HH}	—	—	—	2.5	—	
	Operating DC Potential	CMR	—	—	0	~	3	V
Supply Zener Voltage		V_Z	—	—	5.4	6.0	6.3	V
FG Output Saturation Voltage		$V_{sat}(FG)$	—	$I_{FG} = 5\text{ mA}$	—	0.2	0.4	V
RD Output Saturation Voltage		$V_{sat}(RD)$	—	$I_{RD} = 5\text{ mA}$	—	0.2	0.4	V
Thermal Shutdown Operating Temperature		T_{SD}	—	T_j	150	—	—	°C

APPLICATION CIRCUIT

- 12 V use

- 5 V use

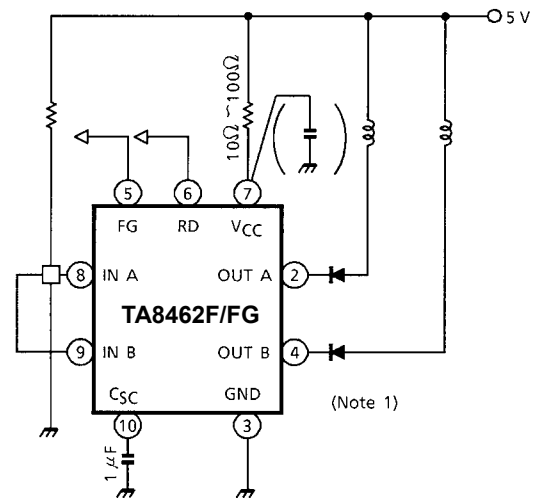
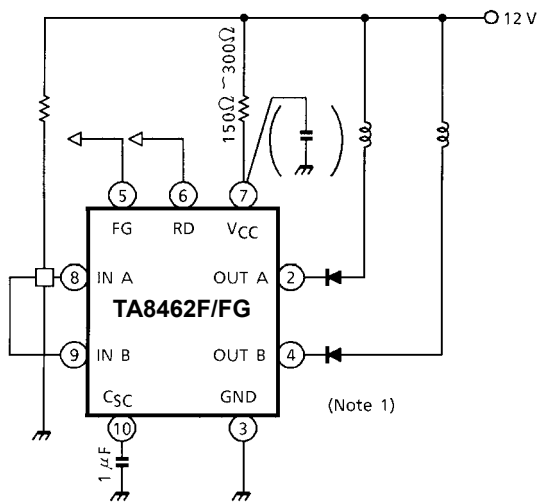

- Note 1: In order to prevent the mutual induction of a motor, connect a additional diode between each output to motor.
- Note 2: Utmost care is necessary in the design of the output, V_{CC} , V_M , and GND lines since the IC may be destroyed by short-circuiting between outputs, air contamination faults, or faults due to improper grounding, or by short-circuiting between contiguous pins.

PACKAGE DIMENSIONS

SSOP10-P-225-1.00

Unit : mm

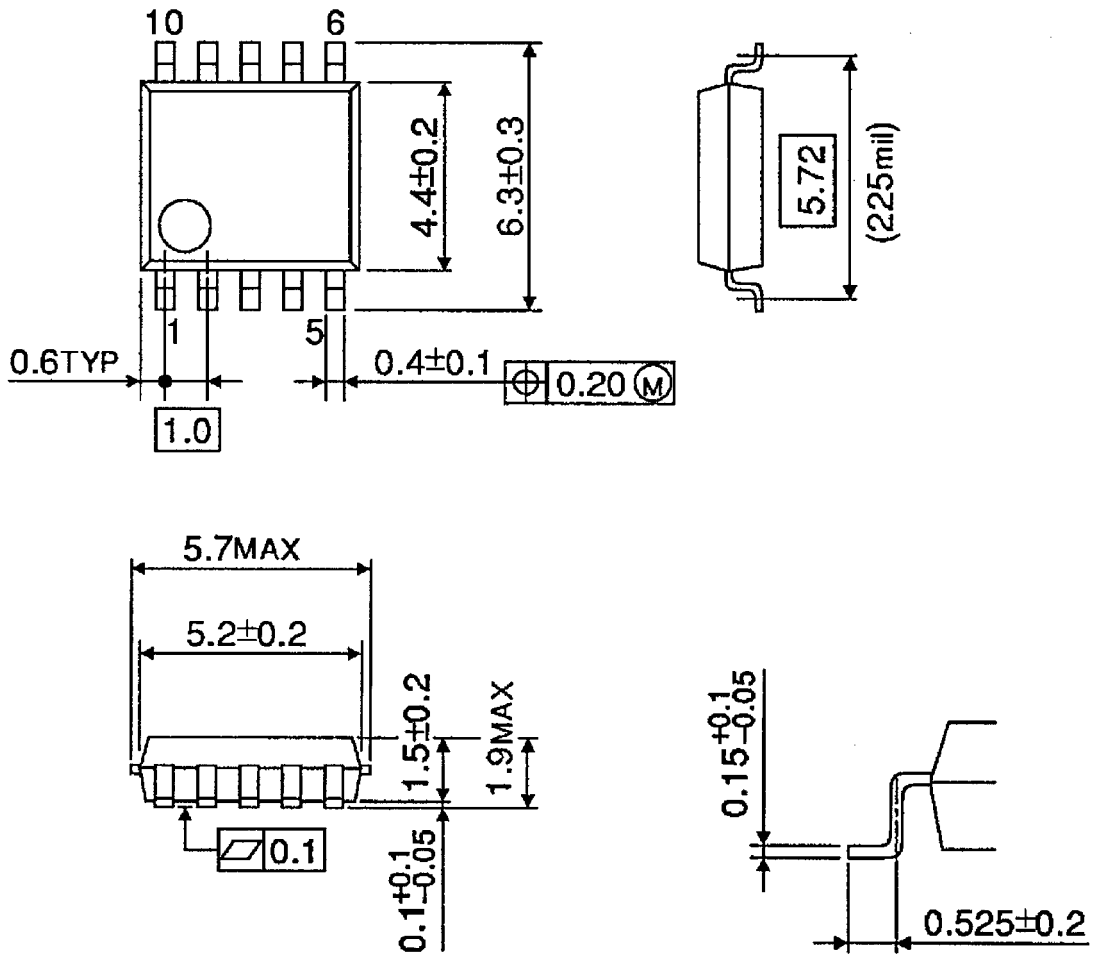

Weight : 0.09 g (Typ.)

Notes on Contents

1. Block Diagrams

Some of the functional blocks, circuits, or constants in the block diagram may be omitted or simplified for explanatory purposes.

2. Equivalent Circuits

The equivalent circuit diagrams may be simplified or some parts of them may be omitted for explanatory purposes.

3. Timing Charts

Timing charts may be simplified for explanatory purposes.

4. Application Circuits

The application circuits shown in this document are provided for reference purposes only. Thorough evaluation is required, especially at the mass production design stage.

Toshiba does not grant any license to any industrial property rights by providing these examples of application circuits.

5. Test Circuits

Components in the test circuits are used only to obtain and confirm the device characteristics. These components and circuits are not guaranteed to prevent malfunction or failure from occurring in the application equipment.

IC Usage Considerations

Notes on handling of ICs

- [1] The absolute maximum ratings of a semiconductor device are a set of ratings that must not be exceeded, even for a moment. Do not exceed any of these ratings.
Exceeding the rating(s) may cause the device breakdown, damage or deterioration, and may result injury by explosion or combustion.
- [2] Use an appropriate power supply fuse to ensure that a large current does not continuously flow in case of over current and/or IC failure. The IC will fully break down when used under conditions that exceed its absolute maximum ratings, when the wiring is routed improperly or when an abnormal pulse noise occurs from the wiring or load, causing a large current to continuously flow and the breakdown can lead smoke or ignition. To minimize the effects of the flow of a large current in case of breakdown, appropriate settings, such as fuse capacity, fusing time and insertion circuit location, are required.
- [3] If your design includes an inductive load such as a motor coil, incorporate a protection circuit into the design to prevent device malfunction or breakdown caused by the current resulting from the inrush current at power ON or the negative current resulting from the back electromotive force at power OFF. IC breakdown may cause injury, smoke or ignition.
Use a stable power supply with ICs with built-in protection functions. If the power supply is unstable, the protection function may not operate, causing IC breakdown. IC breakdown may cause injury, smoke or ignition.
- [4] Do not insert devices in the wrong orientation or incorrectly.
Make sure that the positive and negative terminals of power supplies are connected properly.
Otherwise, the current or power consumption may exceed the absolute maximum rating, and exceeding the rating(s) may cause the device breakdown, damage or deterioration, and may result injury by explosion or combustion.
In addition, do not use any device that is applied the current with inserting in the wrong orientation or incorrectly even just one time.

Points to remember on handling of ICs**(1) Thermal Shutdown Circuit**

Thermal shutdown circuits do not necessarily protect ICs under all circumstances. If the thermal shutdown circuits operate against the over temperature, clear the heat generation status immediately.

Depending on the method of use and usage conditions, such as exceeding absolute maximum ratings can cause the thermal shutdown circuit to not operate properly or IC breakdown before operation.

(2) Heat Radiation Design

In using an IC with large current flow such as power amp, regulator or driver, please design the device so that heat is appropriately radiated, not to exceed the specified junction temperature (T_J) at any time and condition. These ICs generate heat even during normal use. An inadequate IC heat radiation design can lead to decrease in IC life, deterioration of IC characteristics or IC breakdown. In addition, please design the device taking into consideration the effect of IC heat radiation with peripheral components.

(3) Back-EMF

When a motor rotates in the reverse direction, stops or slows down abruptly, a current flow back to the motor's power supply due to the effect of back-EMF. If the current sink capability of the power supply is small, the device's motor power supply and output pins might be exposed to conditions beyond maximum ratings. To avoid this problem, take the effect of back-EMF into consideration in system design.

RESTRICTIONS ON PRODUCT USE

060116EBA

- The information contained herein is subject to change without notice. 021023_D
- TOSHIBA is continually working to improve the quality and reliability of its products. Nevertheless, semiconductor devices in general can malfunction or fail due to their inherent electrical sensitivity and vulnerability to physical stress. It is the responsibility of the buyer, when utilizing TOSHIBA products, to comply with the standards of safety in making a safe design for the entire system, and to avoid situations in which a malfunction or failure of such TOSHIBA products could cause loss of human life, bodily injury or damage to property.
In developing your designs, please ensure that TOSHIBA products are used within specified operating ranges as set forth in the most recent TOSHIBA products specifications. Also, please keep in mind the precautions and conditions set forth in the "Handling Guide for Semiconductor Devices," or "TOSHIBA Semiconductor Reliability Handbook" etc. 021023_A
- The TOSHIBA products listed in this document are intended for usage in general electronics applications (computer, personal equipment, office equipment, measuring equipment, industrial robotics, domestic appliances, etc.). These TOSHIBA products are neither intended nor warranted for usage in equipment that requires extraordinarily high quality and/or reliability or a malfunction or failure of which may cause loss of human life or bodily injury ("Unintended Usage"). Unintended Usage include atomic energy control instruments, airplane or spaceship instruments, transportation instruments, traffic signal instruments, combustion control instruments, medical instruments, all types of safety devices, etc. Unintended Usage of TOSHIBA products listed in this document shall be made at the customer's own risk. 021023_B
- The products described in this document shall not be used or embedded to any downstream products of which manufacture, use and/or sale are prohibited under any applicable laws and regulations. 060106_Q
- The information contained herein is presented only as a guide for the applications of our products. No responsibility is assumed by TOSHIBA for any infringements of patents or other rights of the third parties which may result from its use. No license is granted by implication or otherwise under any patent or patent rights of TOSHIBA or others. 021023_C
- The products described in this document are subject to the foreign exchange and foreign trade laws. 021023_E