



## MT2130 SINGLE-CHIP LOW POWER TERRESTRIAL TUNER

PRODUCT BRIEF

The MT2130 is a single-chip low-power tuner for analog and digital worldwide television standards.



MT2130 Single-Chip Tuner

The MicroTuner™ MT2130 is an advanced low-power terrestrial TV tuner, optimized for portable and power sensitive devices. It has been developed to give manufacturers design flexibility and low cost while maintaining high sensitivity.

The MT2130 receives frequencies in the 48 MHz to 1 GHz range and converts a selected channel to a standard intermediate frequency (IF) between 30 MHz and 57 MHz.

The MT2130's dual-conversion architecture allows for operation of both terrestrial and cable systems without any manual adjustments. This is achieved via the combination of MicroTune's ClearTune technology and an autonomous automatic gain control (AGC). The integrated LNA delivers excellent sensitivity. The innovative gain control and power detector circuits provide reliable terrestrial performance even in hostile signal environments.

The MT2130 can interface with multiple TV transmission standards including ATSC, DVB-T, NTSC, PAL, SECAM and QAM. In addition, the MT2130 provides excellent in-band flatness, as well as consistent gain characteristics across the complete reception band for use in USB TV Receivers, Express Card TV Receivers, portable TVs and TV tuner modules for laptop computers.

## APPLICATIONS

- ATSC/NTSC USB TV receivers
- DVB-T/PAL USB TV receivers
- DVB-T/ATSC USB TV receivers
- ISDB-T receivers
- Express Card TV Receivers
- Cardbus TV Receivers
- Mini Card TV tuner modules for laptop computers
- Portable TVs

## FEATURES

- 48 MHz to 1 GHz input frequency range.
- Low-power 1.2 W dual conversion architecture.
- Integrated front-end band pass filtering
- Integrated RF power detectors and closed-loop RF AGC
- Single-ended RF input
- On-chip low-noise amplifier provides excellent terrestrial sensitivity
- Integrated IF variable gain amplifier for direct connection to digital demodulators
- Interface with ATSC, NTSC, DVB-T, ISDB-T, PAL, SECAM and QAM TV transmission standards.
- Capable of driving multiple IF filters
- Compatible with 3.3 V and 5 V serial bus
- 48 pin, 7 mm X 7 mm QFN package

# MT2130 LOW POWER TERRESTRIAL TUNER

## PRODUCT BRIEF

### RECOMMENDED OPERATING CONDITIONS

PARAMETER	MIN	TYP	MAX	UNIT
Second intermediate center frequency (programmable)	30		57	MHz
Supply voltage 5V	4.75	5.0	5.25	V
Supply voltage 3.3V	3.15	3.3	3.45	V
Supply voltage ripple			15	mV
Operating junction temperature			125	°C
VGA output load impedance	300			Ω
Serial control clock			400	kHz

### ABSOLUTE RATINGS

PARAMETER	MIN	MAX	UNIT
Supply voltage 5V		6	V
Supply voltage 3.3V		3.6	V
Storage temperature range	-40	+150	°C
Lead-free temperature (soldering 5 seconds)		+260	°C
Input voltage	-0.3	VCC +0.3	V

### TUNER ELECTRICAL CHARACTERISTICS

PARAMETER	MIN	TYP	MAX	UNIT
<b>Power Supply</b>				
Active current 5V		190		mA
Active current 3.3V		80		mA
<b>RF Signal Path</b>				
Input frequency range	48		1000	MHz
Noise figure (Off-Air mode)		6		dB
Voltage gain		42		dB
RF AGC range		55		dB
LO phase noise (10 kHz)		-84		dBc/Hz
LO phase noise (100 kHz)		-104		dBc/Hz
LO step size		50		kHz
<b>IF VGA</b>				
Frequency range	30		57	MHz
Maximum output voltage			2.0	Vp-p
Maximum voltage gain		60		dB
IF AGC range		39		dB

PRELIMINARY

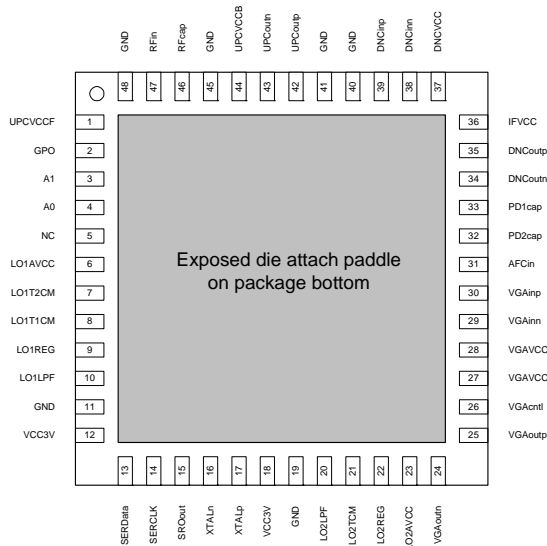

MT2130 Pin Diagram

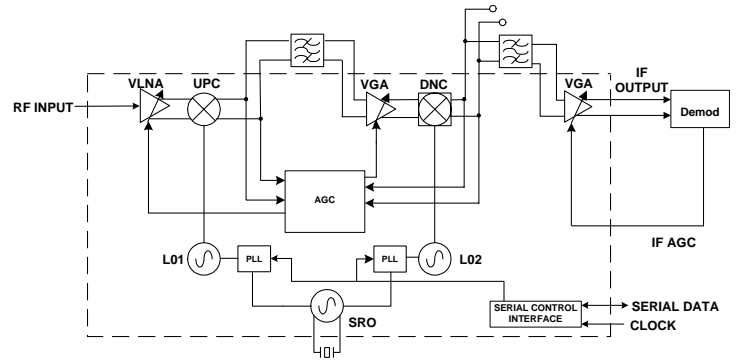

MT2130 Block Diagram



MicroTune, Inc., 2201 Tenth Street, Plano, TX 75074, USA

Tel: +1-972-673-1600, Fax: +1-972-673-1602, E-mail: sales@microtune.com, Web site: [www.microtune.com](http://www.microtune.com)

For a detailed list of office locations, sales offices, and sales representatives, visit our Web site at [www.microtune.com](http://www.microtune.com)

The information in this document is believed to be accurate and reliable. MicroTune assumes no responsibility for any consequences arising from the use of this information, nor from any infringement of patents or the rights of third parties which may result from its use. No license is granted by implication or otherwise under any patent or other rights of MicroTune. The information in this publication replaces and supersedes all information previously supplied, and is subject to change without notice. The customer is responsible for assuring that proper design and operating safeguards are observed to minimize inherent and procedural hazards. MicroTune assumes no responsibility for applications assistance or customer product design.

The devices described in this document are not authorized for use in medical, life-support equipment, or any other application involving a potential risk of severe property or environmental damage, personal injury, or death without prior express written approval of MicroTune. Any such use is understood to be entirely at the user's risk.

MicroTune is a registered trademark of MicroTune, Inc. MicroTuner, MicroStreamer, VideoCaster, DataCaster, and the MicroTune logo are trademarks of MicroTune, Inc. All other trademarks belong to their respective companies.

MicroTune's products are protected by one or more of the following U.S. patents: 5,625,325; 5,648,744; 5,717,730; 5,737,035; 5,739,730; 5,805,988; 5,847,612; 6,100,761; 6,104,242; 6,163,684; 6,169,569; 6,172,378; 6,177,964; 6,211,745; 6,218,899; 6,268,778; 6,310,387; 6,323,736; 6,355,537; 6,429,502; 6,462,327; 6,535,068; 6,580,313; 6,608,522; 6,631,257; 6,714,776; 6,725,463; 6,744,308; 6,771,124; 6,784,945; 6,804,099; 6,888,406; 6,891,435; 6,906,594; 6,909,886; 6,920,182; 6,922,556; 6,963,478; 6,973,288; 6,993,310; 7,035,614; 7,078,960; 7,079,195; D469,742 and additional patents pending or filed.