



Features

- Operating temperature range up to 125 °C
- Low thermal derating factor
- Higher hold currents at elevated temperature
- Choice of operating currents
- RoHS compliant*

Applications

- Protection of automotive circuitry including engine control modules
- Overcurrent surge protection of electronic equipment required to operate at high operating temperature ranges
- Resettable fault protection of general electronic equipment

MF-SMHT Series - PTC Resettable Fuses

Electrical Characteristics

Model	V max. Volts	I max. Amps	I _{hold}	I _{trip}	Resistance		Max. Time To Trip		Tripped Power Dissipation
			Amperes at 23 °C		Ohms at 23 °C		Amperes at 23 °C	Seconds at 23 °C	Watts at 23 °C
			Hold	Trip	R _{Min.}	R _{1Max.}		Max.	Typ.
MF-SMHT136	16	100	1.36	2.72	0.085	0.33	8.0	10.0	2.1
MF-SMHT160	16	100	1.60	3.20	0.050	0.15	8.0	10.0	2.1

Environmental Characteristics

Operating Temperature	-40 °C to +125 °C
Storage Temperature	-40 °C to +85 °C
Passive Aging	+125 °C, 1000 hours±15 % typical resistance change
Humidity Aging	+85 °C, 85 % R.H. 7 days±15 % typical resistance change
Thermal Shock	MIL-STD-202F, Method 107G,±15 % typical resistance change +125 °C to -55 °C, 10 cycles
Vibration	MIL-STD-883C, Method 2007.1, Condition ANo change

Test Procedures And Requirements For Model MF-SMHT Series

Test	Test Conditions	Accept/Reject Criteria
Visual/Mech.	Verify dimensions and materials	Per MF physical description
Resistance	In still air @ 23 °C	R _{min} ≤ R ≤ R _{1max}
Time to Trip	At specified current, V _{max} , 23 °C	T ≤ max. time to trip (seconds)
Hold Current	.30 min. at I _{hold}	No trip
Trip Cycle Life	V _{max} , I _{max} , 100 cycles	No arcing or burning
Trip Endurance	V _{max} , 48 hours	No arcing or burning
Solderability	MIL-STD-202F, Method 208F	95 % min. coverage

Thermal Derating Chart - I_{hold} / I_{trip} (Amps)

Model	Ambient Operating Temperature									
	-40 °C	-20 °C	0 °C	23 °C	40 °C	50 °C	60 °C	70 °C	85 °C	125 °C
MF-SMHT136	1.91 / 3.82	1.72 / 3.44	1.54 / 3.08	1.36 / 2.72	1.18 / 2.36	1.09 / 2.18	1.00 / 2.00	0.91 / 1.82	0.77 / 1.54	0.40 / 0.80
MF-SMHT160	2.15 / 4.30	1.96 / 3.92	1.78 / 3.56	1.60 / 3.20	1.42 / 2.84	1.33 / 2.66	1.24 / 2.48	1.15 / 3.30	1.02 / 2.04	0.64 / 1.28



Circuit Protection Division

Asia-Pacific:

Tel: +886-2 2562-4117 • Fax: +886-2 2562-4116

Europe:

Tel: +41-41 768 5555 • Fax: +41-41 768 5510

The Americas:

Tel: +1-951 781-5500 • Fax: +1-951 781-5700

www.bourns.com

*RoHS Directive 2002/95/EC Jan 27 2003 including Annex

Specifications are subject to change without notice.

Customers should verify actual device performance in their specific applications.

MF-SMHT Series - PTC Resettable Fuses

BOURNS®

Product Dimensions

Model	A		B	C	D		E		F		G		H
	Min.	Max.	Max.	Max.	Min.	Max.	Min.	Max.	Min.	Max.	Min.	Max.	Min.
MF-SMHT136	6.73 (0.265)	7.98 (0.314)	3.00 (0.118)	5.44 (0.214)	0.56 (0.022)	0.71 (0.028)	0.56 (0.022)	0.71 (0.028)	2.16 (0.085)	2.41 (0.095)	0.66 (0.026)	1.37 (0.054)	0.43 (0.017)
MF-SMHT160	8.00 (0.315)	9.50 (0.374)	3.00 (0.118)	6.71 (0.264)	0.56 (0.022)	0.71 (0.028)	0.56 (0.022)	0.71 (0.028)	3.68 (0.145)	3.94 (0.155)	0.66 (0.026)	1.37 (0.054)	0.43 (0.017)

Packaging:

TAPE & REEL: MF-SMHT136 = 2000 pcs. per reel;
MF-SMHT160 = 1500 pcs. per reel.

UNIT = $\frac{\text{MM}}{\text{(INCHES)}}$

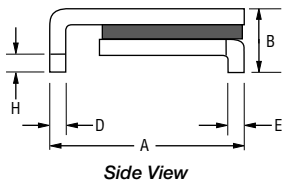

Terminal material:
Tin-plated brass

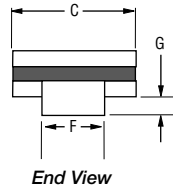

Typical Part Marking

Represents total content. Layout may vary.

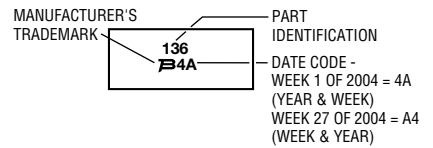

How to Order

MF - SMHT 136 - 2

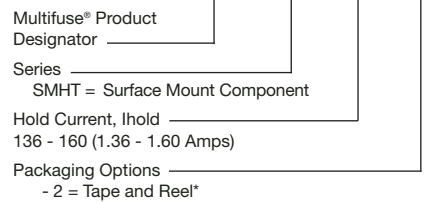

*Packaged per EIA-481-2

Recommended Pad Layout MF-SMHT136

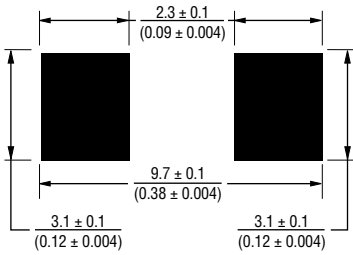

Recommended Pad Layout MF-SMHT160

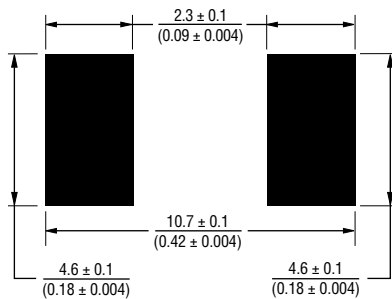

MF-SMHT Series - PTC Resettable Fuses



Typical Time to Trip at 23 °C

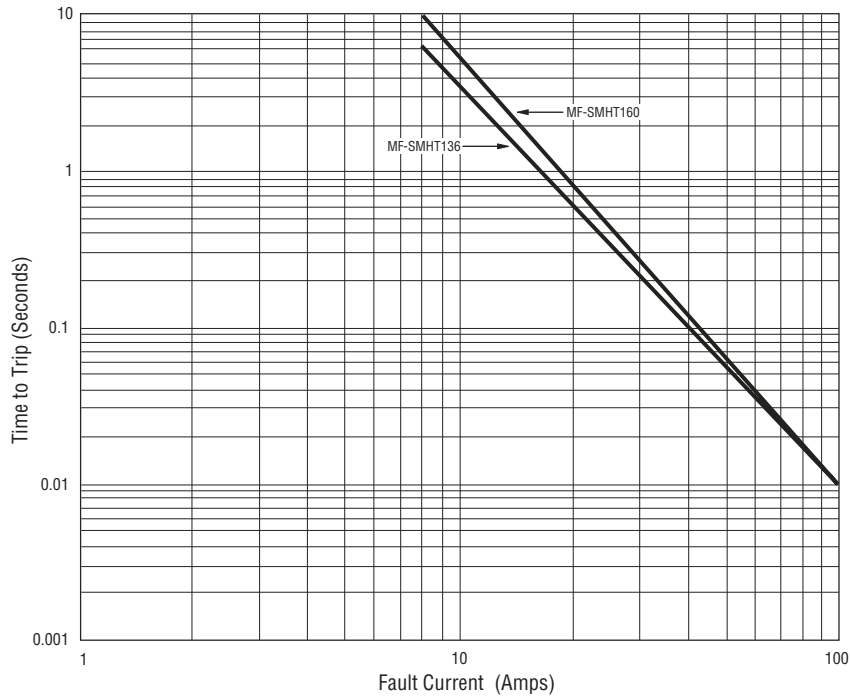

The Time to Trip curves represent typical performance of a device in a simulated application environment. Actual performance in specific customer applications may differ from these values due to the influence of other variables.

Solder Reflow Recommendations

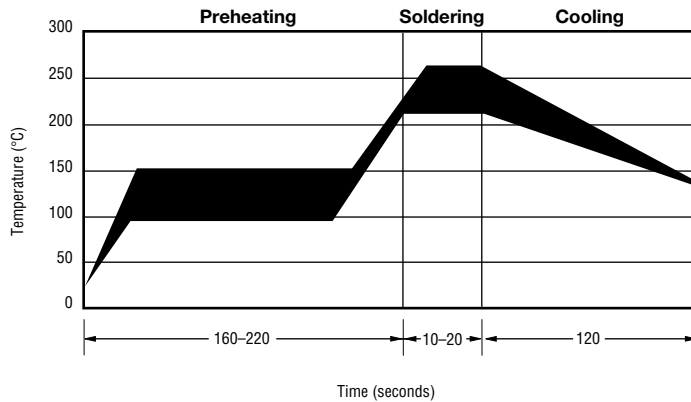

Solder reflow

- Recommended reflow methods: IR, vapor phase oven, hot air oven.
- Devices are not designed to be wave soldered to the bottom side of the board.
- Gluing the devices is not recommended.
- Recommended maximum paste thickness is 0.25 mm (.010 inch).
- Devices can be cleaned using standard industry methods and solvents.

Note:

- If reflow temperatures exceed the recommended profile, devices may not meet the performance requirements.

Rework

- A device should not be reworked.

MF-SMHT Series Tape and Reel Specifications

BOURNS®

Tape Dimensions	MF-SMHT136 per EIA-481-2	MF-SMHT160 per EIA 481-2
W	$\frac{16.0 \pm 0.3}{(0.630 \pm 0.012)}$	$\frac{16.0 \pm 0.3}{(0.630 \pm 0.012)}$
P ₀	$\frac{4.0 \pm 0.1}{(0.157 \pm 0.004)}$	$\frac{4.0 \pm 0.1}{(0.157 \pm 0.004)}$
P ₁	$\frac{8.0 \pm 0.1}{(0.315 \pm 0.004)}$	$\frac{12.0 \pm 0.1}{(0.472 \pm 0.004)}$
P ₂	$\frac{2.0 \pm 0.1}{(0.079 \pm 0.004)}$	$\frac{2.0 \pm 0.1}{(0.079 \pm 0.004)}$
A ₀	$\frac{5.7 \pm 0.1}{(0.224 \pm 0.004)}$	$\frac{6.9 \pm 0.1}{(0.272 \pm 0.004)}$
B ₀	$\frac{8.1 \pm 0.1}{(0.319 \pm 0.004)}$	$\frac{9.6 \pm 0.1}{(0.378 \pm 0.004)}$
B ₁ max.	$\frac{12.1}{(0.476)}$	$\frac{12.1}{(0.476)}$
D ₀	$\frac{1.5 + 0.1/-0.0}{(0.059 + 0.004/-0)}$	$\frac{1.5 + 0.1/-0.0}{(0.059 + 0.004/-0)}$
F	$\frac{7.5 \pm 0.1}{(0.295 \pm 0.004)}$	$\frac{7.5 \pm 0.1}{(0.295 \pm 0.004)}$
E ₁	$\frac{1.75 \pm 0.1}{(0.069 \pm 0.004)}$	$\frac{1.75 \pm 0.1}{(0.069 \pm 0.004)}$
E ₂ min.	$\frac{14.25}{(0.561)}$	$\frac{14.25}{(0.561)}$
T max.	$\frac{0.6}{(0.024)}$	$\frac{0.6}{(0.024)}$
T ₁ max.	$\frac{0.1}{(0.004)}$	$\frac{0.1}{(0.004)}$
K ₀	$\frac{3.4 \pm 0.1}{(0.134 \pm 0.004)}$	$\frac{3.4 \pm 0.1}{(0.134 \pm 0.004)}$
Leader min.	$\frac{390}{(15.35)}$	$\frac{390}{(15.35)}$
Trailer min.	$\frac{160}{(6.30)}$	$\frac{160}{(6.30)}$
Reel Dimensions		
A max.	$\frac{360}{(14.17)}$	$\frac{360}{(14.17)}$
N min.	$\frac{50}{(1.97)}$	$\frac{50}{(1.97)}$
W ₁	$\frac{16.4 + 2.0/-0.0}{(0.646 + 0.079/-0)}$	$\frac{16.4 + 2.0/-0.0}{(0.646 + 0.079/-0)}$
W ₂ max.	$\frac{22.4}{(0.882)}$	$\frac{22.4}{(0.882)}$

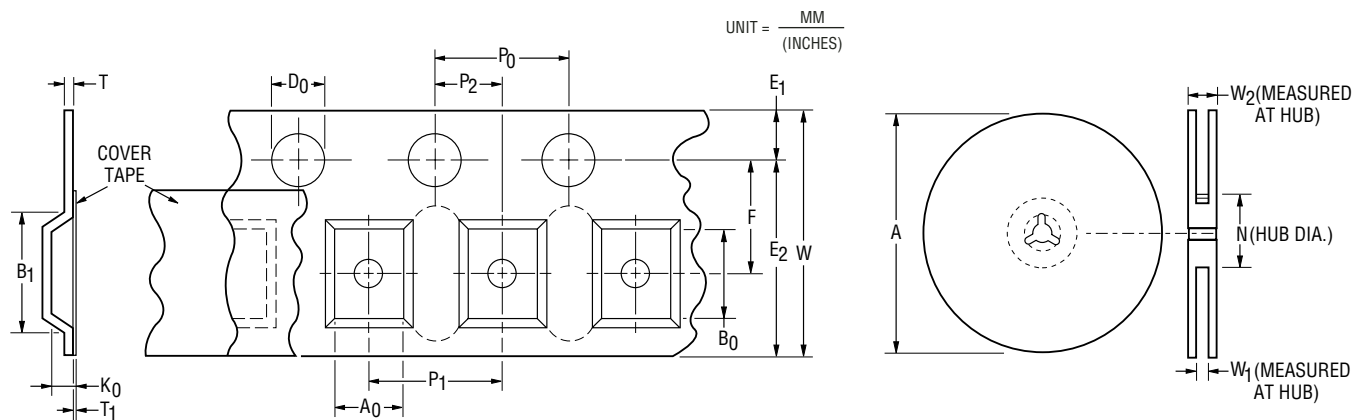

Specifications are subject to change without notice.
Customers should verify actual device performance in their specific applications.