

# FAN2103 — TinyBuck™

## 3A, 24V Input Integrated Synchronous Buck Regulator

### Features

- Over 95% efficiency
- Internal power MOSFETs:  
High-side  $R_{DS(ON)} = 31m\Omega$   
Low-side  $R_{DS(ON)} = 23m\Omega$
- Integrated low-side Schottky diode
- Programmable frequency operation up to 750KHz
- Power-good signal
- Wide input range: 3.0V to 24V
- Output voltage range: 0.8V to 90% $V_{IN}$
- Input under-voltage lockout (UVLO)
- Programmable over-current protection
- Under-voltage, over-voltage, and thermal protection
- Selectable light-load power-saving mode
- 5x6mm, 25-pin, 3-pad MLP

### Applications

- Thin and light Notebook PCs
- Graphics cards
- Battery-powered equipment
- Set-top box
- Point-of-load regulation

### Description

The FAN2103 TinyBuck™ is an easy-to-use, cost- and space-efficient, synchronous buck solution. It enables designers to solve high-current requirements in a small area with minimal external components.

External programming of clock frequency, current limit, and loop response allows for optimization and flexibility selecting output filter components and transient response.

The summing current mode modulator uses lossless current sensing for current feedback and over-current, and includes voltage feedforward.

Fairchild's advanced BiCMOS power process, combined with a thermally efficient MLP package, provides low- $R_{DS(ON)}$ , internal MOSFETs, and the ability to dissipate high power in a small package.

Under-voltage, thermal shutdown, and power-good are blanked at start-up, but protect the device from damage during fault conditions.

### Related Application Notes

- [AN-5067 – PCB land pattern design and surface mount guidelines for MLP packages](#)

### Ordering Information

| Part Number | Operating Temperature Range | Package                                    | Packing Method |
|-------------|-----------------------------|--|----------------|
| FAN2103MPX  | -10°C to 85°C               | 25-Pin Molded Leadless Package (MLP) 5x6mm | Tape and Reel  |
| FAN2103EMPX | -40°C to 85°C               | 25-Pin Molded Leadless Package (MLP) 5x6mm | Tape and Reel  |

 All packages are lead free per JEDEC: J-STD-020B standard.

### Typical Application Diagram

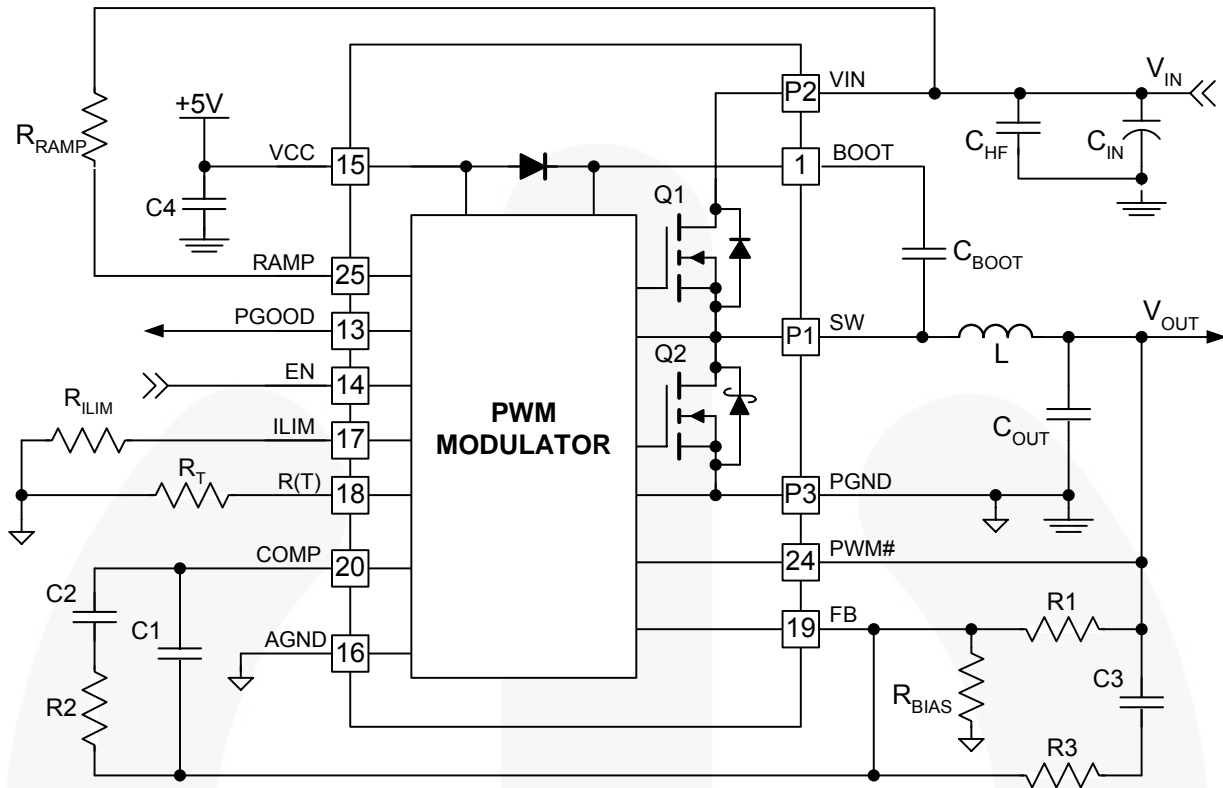

Figure 1. Typical Application

### Block Diagram

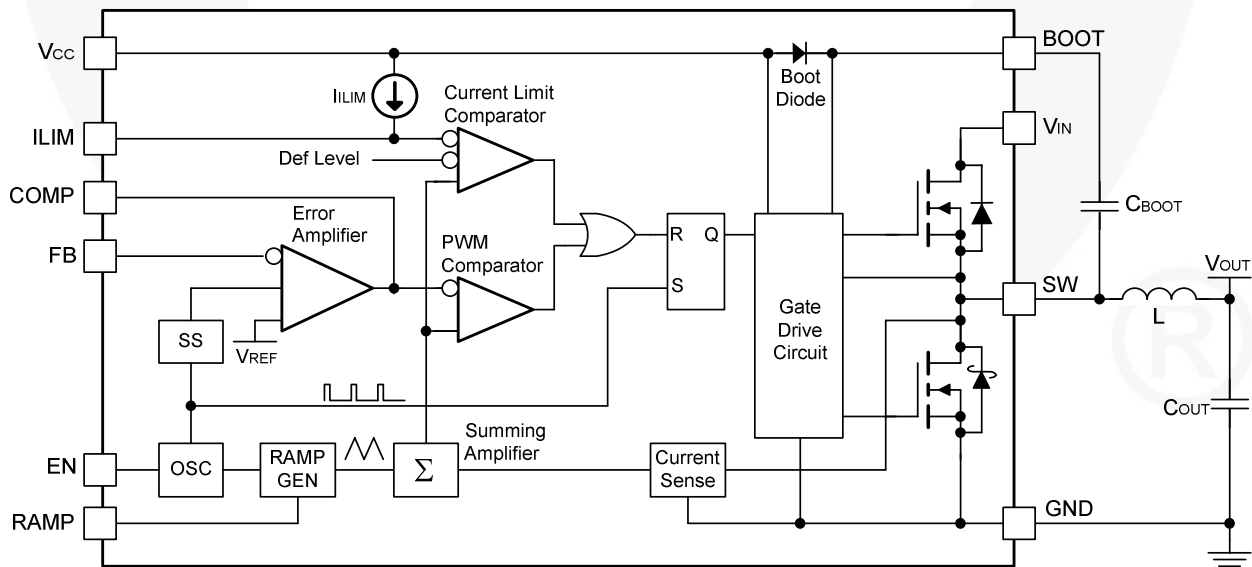

Figure 2. Block Diagram

## Pin Configuration

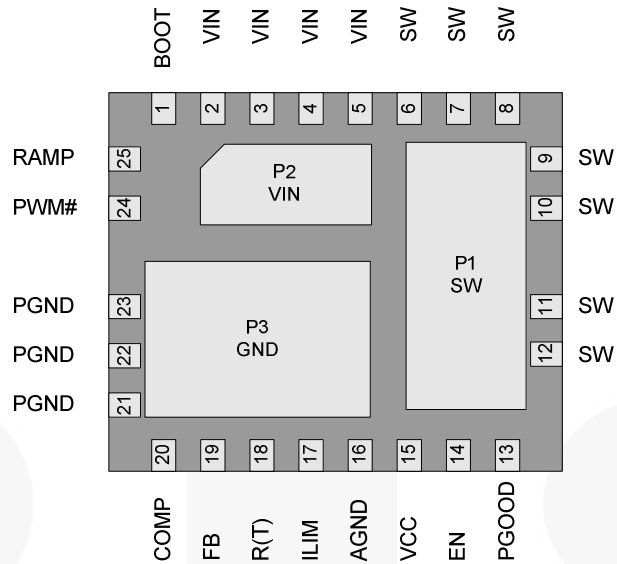

Figure 3. MLP 5x6mm Pin Configuration (Bottom View)

## Pin Definitions

| Pin       | Name  | Description   |
|-----------|-------|---|
| P1, 6-12  | SW    | <b>Switching Node.</b>  |
| P2, 2-5   | VIN   | <b>Power Input Voltage.</b> Connect to the main input power source.   |
| P3, 21-23 | PGND  | <b>Power Ground.</b> Power return and Q2 source.  |
| 1         | BOOT  | <b>High-side Drive BOOT Voltage.</b> Connect through capacitor ( $C_{BOOT}$ ) to SW. The IC includes an internal synchronous bootstrap diode to recharge the capacitor on this pin to $V_{CC}$ when SW is LOW.  |
| 13        | PGOOD | <b>Power-Good Flag.</b> An open-drain output that pulls LOW when FB is outside a $\pm 10\%$ range of the reference when EN is HIGH. PGOOD does not assert HIGH until the fault latch is enabled.  |
| 14        | EN    | <b>ENABLE.</b> Enables operation when pulled to logic HIGH or left open. Toggling EN resets the regulator after a latched fault condition. This input has an internal pull-up when the IC is functioning normally. When a latched fault occurs, EN is discharged by a current sink. |
| 15        | VCC   | <b>Input Bias Supply for IC.</b> The IC's logic and analog circuitry are powered from this pin.   |
| 16        | AGND  | <b>Analog Ground.</b> The signal ground for the IC. All internal control voltages are referred to this pin. Tie this pin to the ground island/plane through the lowest impedance connection.  |
| 17        | ILIM  | <b>Current Limit.</b> A resistor ( $R_{ILIM}$ ) from this pin to AGND can be used to program the current-limit trip threshold lower than the default setting.   |
| 18        | R(T)  | <b>Oscillator Frequency.</b> A resistor ( $R_T$ ) from this pin to AGND sets the PWM switching frequency.   |
| 19        | FB    | <b>Output Voltage Feedback.</b> Connect through a resistor divider to the output voltage.   |
| 20        | COMP  | <b>Compensation.</b> Error amplifier output. Connect the external compensation network between this pin and FB.   |
| 24        | PWM#  | <b>Power Save Mode / Forced PWM.</b> Connect to $V_{CC}$ to enable light-load, power-saving mode of operation. Connect to GND or leave open for fixed-frequency PWM mode.   |
| 25        | RAMP  | <b>Ramp Amplitude.</b> A resistor ( $R_{RAMP}$ ) connected from this pin to VIN sets the ramp amplitude and provides voltage feedforward functionality.   |

## Absolute Maximum Ratings

Stresses exceeding the absolute maximum ratings may damage the device. The device may not function or be operable above the recommended operating conditions and stressing the parts to these levels is not recommended. In addition, extended exposure to stresses above the recommended operating conditions may affect device reliability. The absolute maximum ratings are stress ratings only.

| Parameter               | Conditions                        | Min. | Max.                 | Unit |
|-------------------------|-----------------------------------|------|----------------------|------|
| V <sub>IN</sub> to PGND |                                   |      | 28                   | V    |
| V <sub>CC</sub> to AGND | AGND = PGND                       |      | 6                    | V    |
| BOOT to PGND            |                                   |      | 35                   | V    |
| BOOT to SW              |                                   | -0.3 | 6.0                  | V    |
| SW to PGND              | Transient (t < 20ns, F ≤ 600KHz)  | -5   | 30                   | V    |
| All other pins          |                                   | -0.3 | V <sub>CC</sub> +0.3 | V    |
| ESD                     | Human Body Model, JESD22-A114     | 2.0  |                      | kV   |
|                         | Charged Device Model, JESD22-C101 | 2.0  |                      |      |

## Recommended Operating Conditions

The Recommended Operating Conditions table defines the conditions for actual device operation. Recommended operating conditions are specified to ensure optimal performance to the datasheet specifications. Fairchild does not recommend exceeding them or designing to absolute maximum ratings.

| Symbol          | Parameter            | Conditions              | Min. | Typ. | Max. | Unit |
|-----------------|----------------------|-------------------------|------|------|------|------|
| V <sub>CC</sub> | Bias Voltage         | V <sub>CC</sub> to AGND | 4.5  | 5.0  | 5.5  | V    |
| V <sub>IN</sub> | Supply Voltage       | V <sub>IN</sub> to PGND | 3    |      | 24   | V    |
| T <sub>A</sub>  | Ambient Temperature  | FAN2103M                | -10  |      | +85  | °C   |
|                 |                      | FAN2103EM               | -40  |      | +85  | °C   |
| T <sub>J</sub>  | Junction Temperature |                         |      |      | +125 | °C   |

## Thermal Information

| Symbol             | Parameter  | Min.    | Typ.              | Max.               | Unit |
|--------------------|--|---------|-------------------|--------------------|------|
| T <sub>STG</sub>   | Storage Temperature                              | -65     |                   | +150               | °C   |
| T <sub>L</sub>     | Lead Soldering Temperature, 10 Seconds           |         |                   | +300               | °C   |
| T <sub>VP</sub>    | Vapor Phase, 60 Seconds                          |         |                   | +215               | °C   |
| T <sub>I</sub>     | Infrared, 15 Seconds                             |         |                   | +220               | °C   |
| θ <sub>JC</sub>    | Thermal Resistance: Junction-to-Case             | P1 (Q2) | 4                 |                    | °C/W |
|                    |  | P2 (Q1) | 7                 |                    | °C/W |
|                    |  | P3      | 4                 |                    | °C/W |
| θ <sub>J-PCB</sub> | Thermal Resistance: Junction-to-Mounting Surface |         | 35 <sup>(1)</sup> |                    | °C/W |
| P <sub>D</sub>     | Power Dissipation, T <sub>A</sub> = 25°C         |         |                   | 2.8 <sup>(1)</sup> | W    |

### Note:

- Typical thermal resistance when mounted on a four-layer, two-ounce PCB, as shown in Figure 26. Actual results are dependent on mounting method and surface related to the design.

## Electrical Specifications

Recommended operating conditions are the result of using the circuit shown in Figure 1 unless otherwise noted.

| Parameter                             | Conditions  | Min. | Typ. | Max. | Unit              |
|---------------------------------------|---|------|------|------|-------------------|
| <b>Power Supplies</b>                 |   |      |      |      |                   |
| V <sub>CC</sub> Current               | SW = Open, FB = 0.7V, V <sub>CC</sub> = 5V,<br>F <sub>SW</sub> = 600KHz                       |      | 8    | 12   | mA                |
|                                       | Shutdown: EN = 0, V <sub>CC</sub> = 5V  |      | 7    | 10   | μA                |
|                                       | Power Saving Mode, V <sub>CC</sub> = 5V, F <sub>MIN</sub>                                     |      | 2.2  | 4.5  | mA                |
| V <sub>CC</sub> UVLO Threshold        | Rising V <sub>CC</sub>  | 4.1  | 4.3  | 4.5  | V                 |
|                                       | Hysteresis  |      | 300  |      | mV                |
| <b>Power Output Section</b>           |   |      |      |      |                   |
| N-Channel (Q1) R <sub>DS(ON)</sub>    | V <sub>CC</sub> = 5V, 25°C  |      | 31   | 35   | mΩ                |
| N-Channel (Q2) R <sub>DS(ON)</sub>    |   |      | 23   | 25   | mΩ                |
| <b>Oscillator</b>                     |   |      |      |      |                   |
| Frequency                             | R <sub>T</sub> = 50KΩ   | 255  | 300  | 345  | KHz               |
|                                       | R <sub>T</sub> = 24KΩ   | 540  | 600  | 660  | KHz               |
| Minimum On-Time <sup>(2)</sup>        |   |      | 50   | 65   | ns                |
| Ramp Amplitude, pk-pk                 | 16V <sub>IN</sub> , 1.8V <sub>OUT</sub> , R <sub>T</sub> = 30KΩ,<br>R <sub>RAMP</sub> = 200KΩ |      | 0.53 |      | V                 |
| Minimum Off-Time <sup>(2)</sup>       |   |      | 100  | 150  | ns                |
| <b>Reference</b>                      |   |      |      |      |                   |
| Reference Voltage (V <sub>FB</sub> )  | FAN2103M, 25°C  | 794  | 800  | 806  | mV                |
|                                       | FAN2103EM, 25°C   | 795  | 800  | 805  | mV                |
| FAN2103M,                             | Temp. Coefficient (-10 to +85°C)  |      | 50   |      | PPM               |
| FAN2103EM                             | Temp. Coefficient (-40 to +85°C)  |      | 70   |      | PPM               |
| <b>Error Amplifier</b>                |   |      |      |      |                   |
| DC Gain <sup>(2)</sup>                | V <sub>CC</sub> = 5V  | 80   | 85   |      | dB                |
| Gain Bandwidth Product <sup>(2)</sup> |   | 12   | 15   |      | MHz               |
| Output Voltage (V <sub>COMP</sub> )   |   | 0.4  |      | 3.2  | V                 |
| Output Current, Sourcing              | V <sub>CC</sub> = 5V, V <sub>COMP</sub> = 2.2V  | 1.5  | 2.2  |      | mA                |
| Output Current, Sinking               | V <sub>CC</sub> = 5V, V <sub>COMP</sub> = 1.2V  | 0.8  | 1.2  |      | mA                |
| FB Bias Current                       | V <sub>FB</sub> = 0.8V, 25°C  | -850 | -650 | -450 | nA                |
| <b>Protection and Shutdown</b>        |   |      |      |      |                   |
| Current Limit                         | R <sub>LIM</sub> open   | 3.8  | 5.0  | 7.0  | A                 |
| I <sub>LIM</sub> Current              | 25°C, V <sub>CC</sub> = 5V  | 9    | 10   | 11   | μA                |
| Over-Temperature Shutdown             | Internal Temperature  |      | 160  |      | °C                |
| Over-Temperature Hysteresis           |   |      |      | 30   |                   |
| Over-Voltage Threshold                | 2 Consecutive Clock Cycles  | 110  | 115  | 120  | %V <sub>OUT</sub> |
| Under-Voltage Shutdown                | 16 Consecutive Clock Cycles   | 68   | 73   | 78   | %V <sub>OUT</sub> |
| Fault Discharge Threshold             | Measured at FB Pin  |      | 250  |      | mV                |
| Fault Discharge Hysteresis            | Measured at FB Pin (V <sub>FB</sub> ~500mV)   |      | 250  |      | mV                |

**Note:**

- Specifications guaranteed by design and characterization; not production tested.

**Electrical Specifications** (Continued)

Recommended operating conditions are the result of using the circuit shown in Figure 1 unless otherwise noted.

| Parameter  | Conditions                  | Min. | Typ. | Max. | Unit             |
|--|-----------------------------|------|------|------|------------------|
| <b>Soft-Start</b>                                  |                             |      |      |      |                  |
| V <sub>OUT</sub> to Regulation (T <sub>0.8</sub> ) | Frequency = 600KHz          |      | 5.3  |      | ms               |
| Fault Enable/SSOK (T <sub>1.0</sub> )              |                             |      | 6.7  |      | ms               |
| <b>Control Functions</b>                           |                             |      |      |      |                  |
| EN Threshold, Rising                               |                             |      | 1.35 | 2.00 | V                |
| EN Hysteresis                                      |                             |      | 250  |      | mV               |
| EN Pull-up Resistance                              |                             |      | 800  |      | K $\Omega$       |
| EN Discharge Current                               | Auto-restart Mode           |      | 1    |      | $\mu$ A          |
| FB OK Drive Resistance                             |                             |      |      | 800  | $\Omega$         |
| PGOOD Threshold                                    | FB < V <sub>REF</sub>       | -14  | -11  | -8   | %V <sub>FB</sub> |
|  | FB > V <sub>REF</sub>       | 107  | 110  | 113  | %V <sub>FB</sub> |
| PGOOD Output Low                                   | I <sub>OUT</sub> $\leq$ 2mA |      |      | 0.4  | V                |
| PGOOD Output High                                  | V <sub>PGOOD</sub> = 5V     |      |      | 1    | $\mu$ A          |
| PWM# Threshold                                     |                             |      | 0.6  | 0.8  | V                |
| PWM# Input Current                                 | V <sub>PWM#</sub> = 0.4V    |      | 1.0  | 1.2  | $\mu$ A          |

## Typical Characteristics

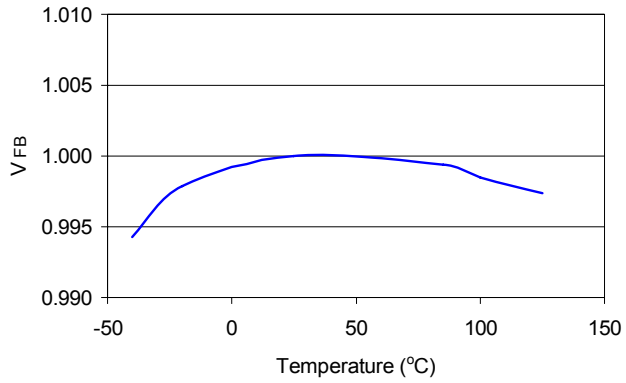

**Figure 4. Reference Voltage ( $V_{FB}$ ) vs. Temperature, Normalized**

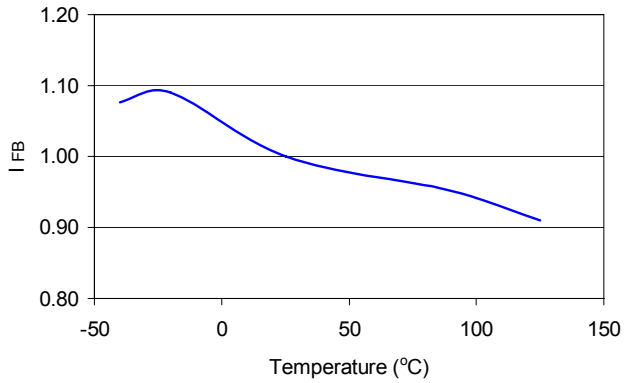

**Figure 5. Reference Bias Current ( $I_{FB}$ ) vs. Temperature, Normalized**

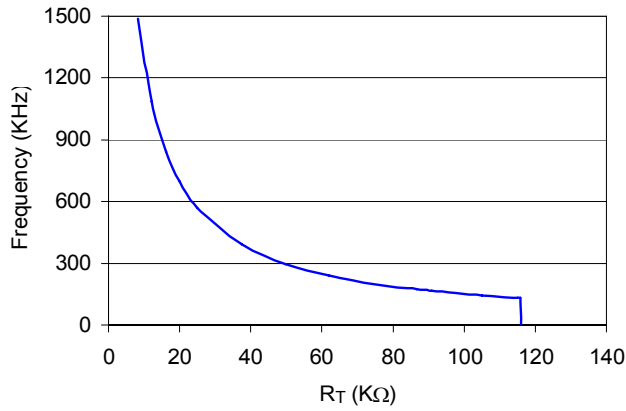

**Figure 6. Frequency vs.  $R_T$**

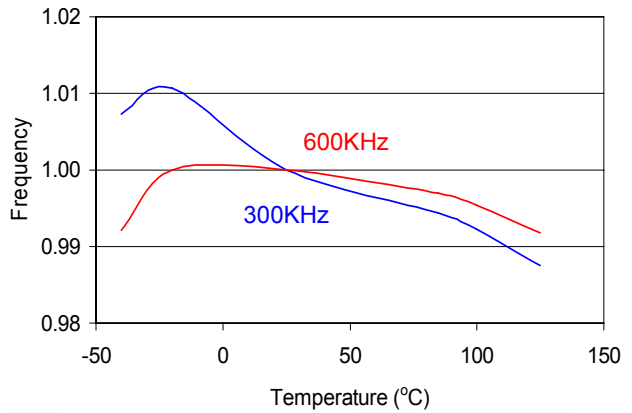

**Figure 7. Frequency vs. Temperature, Normalized**

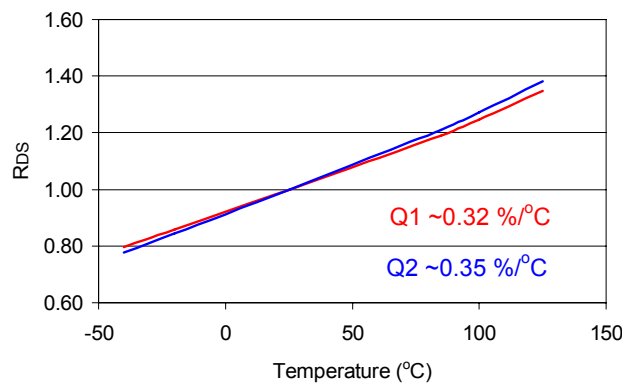

**Figure 8.  $R_{DS}$  vs. Temperature, Normalized ( $V_{CC} = V_{GS} = 5V$ )**

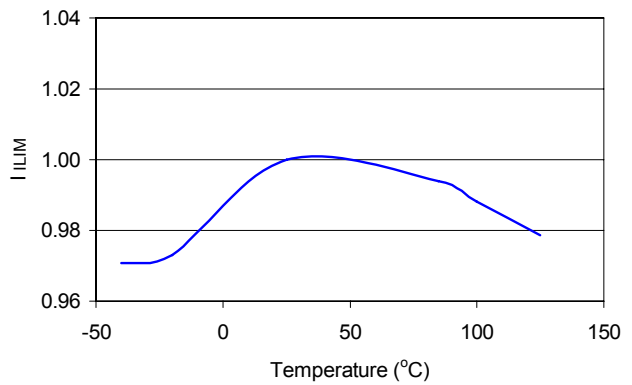

**Figure 9.  $I_{ILIM}$  Current ( $I_{ILIM}$ ) vs. Temperature, Normalized**

### Application Circuit

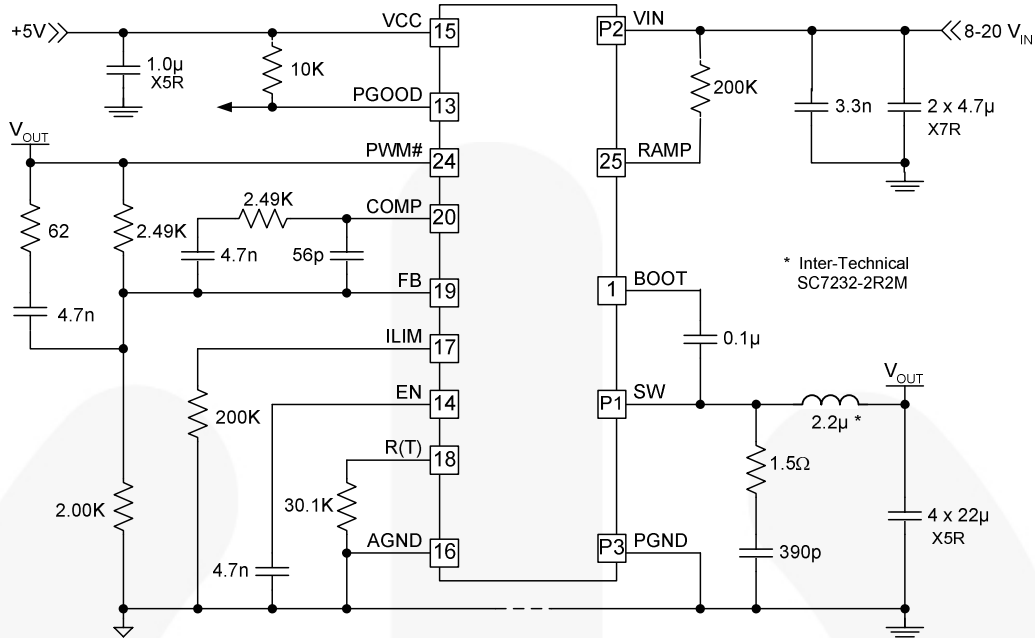

Figure 10. Application Circuit: 1.8 V<sub>OUT</sub>, 500KHz

### Typical Performance Characteristics

Typical operating characteristics using the circuit shown in Figure 10. V<sub>IN</sub>=16V, V<sub>CC</sub>=5V, unless otherwise specified.

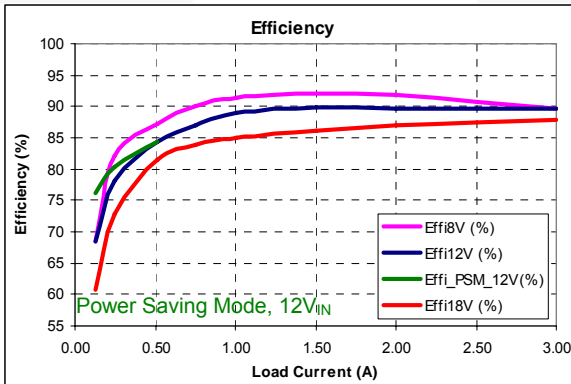

Figure 11. 1.8 V<sub>OUT</sub> Efficiency Over V<sub>IN</sub> vs. Load

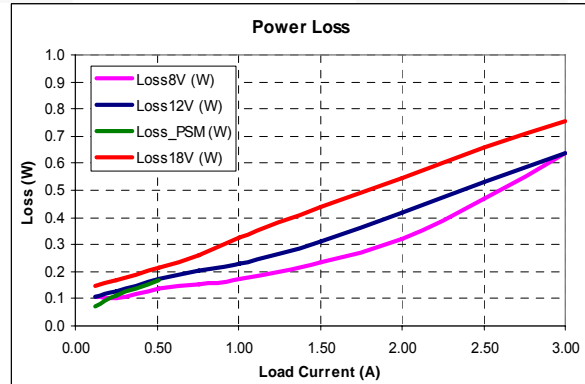

Figure 12. 1.8 V<sub>OUT</sub> Dissipation Over V<sub>IN</sub> vs. Load

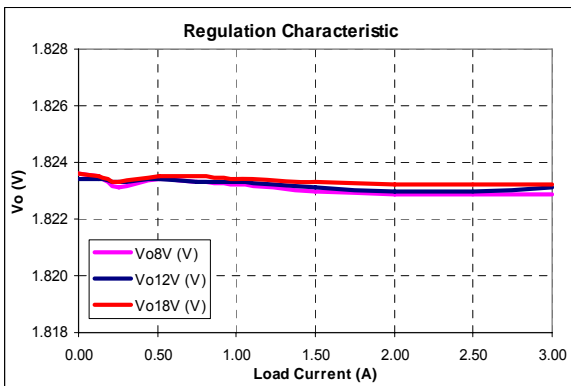

Figure 13. 1.8 V<sub>OUT</sub> Regulation vs. Load

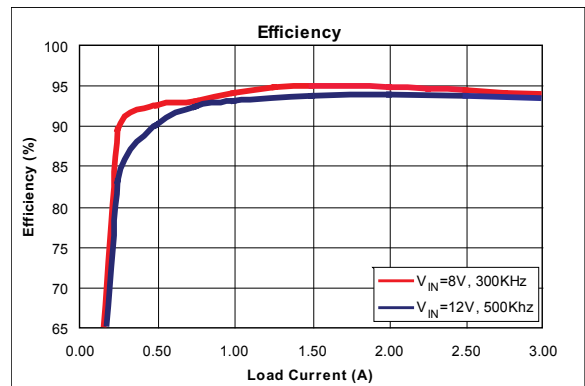

Figure 14. 3.3 V<sub>OUT</sub> Efficiency vs. Load (Circuit Values Changed)



## Typical Performance Characteristics (Continued)

Typical operating characteristics using the circuit shown in Figure 10.  $V_{IN}=12V$ ,  $V_{CC}=5V$ , unless otherwise specified.

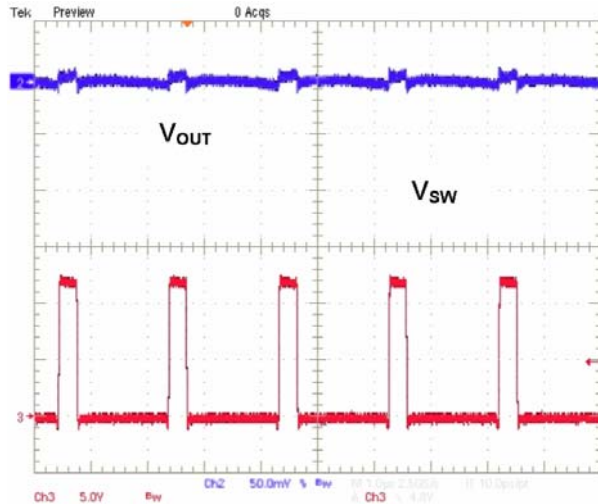

Figure 15. SW and  $V_{OUT}$  Ripple, 3A Load

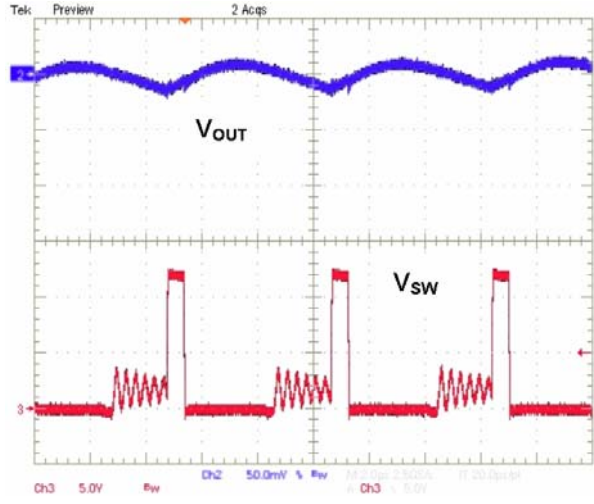

Figure 16. SW and  $V_{OUT}$  Ripple, 0.5A Load

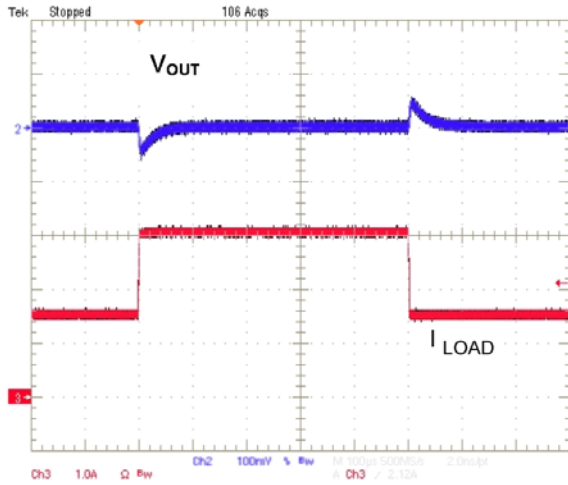

Figure 17. Transient Response, 1.5-3A Load  
(Circuit Values Changed)

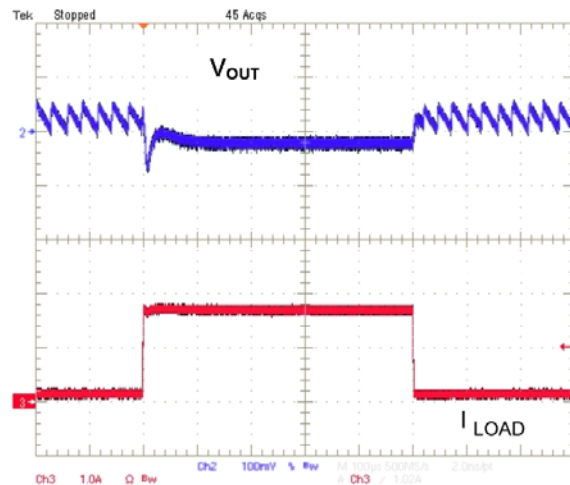

Figure 18. Transient Response, 0.3-3A Load  
(Circuit Values Changed)

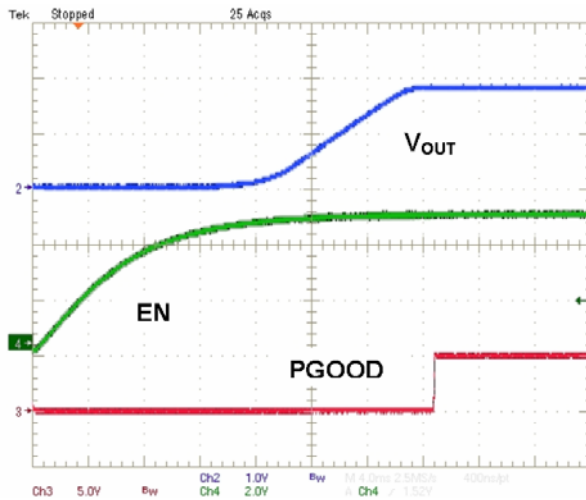

Figure 19. Start-up, 3A Load

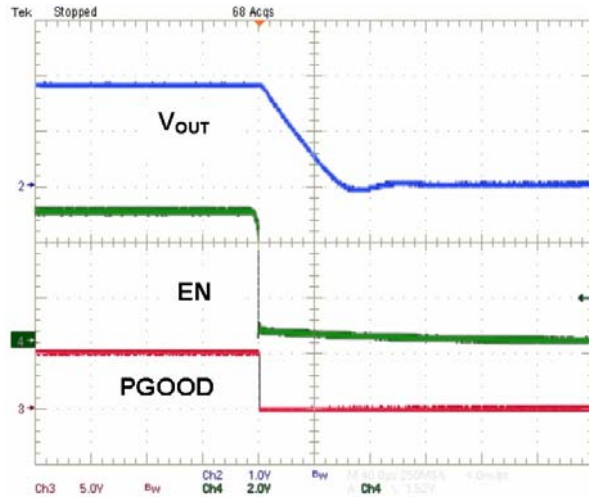

Figure 20. Shutdown, 3A Load

## Circuit Description

### Initialization

Once  $V_{CC}$  exceeds the UVLO threshold and EN is HIGH, the IC checks for an open or shorted FB pin before releasing the internal soft-start ramp (SS).

If R1 is open, the error amplifier output (COMP) is forced LOW and no pulses are generated. After the SS ramp times out (T1.0), an under-voltage latched fault occurs.

If the parallel combination of R1 and  $R_{BIAS}$  is  $\leq 1K\Omega$ , the internal SS ramp is not released and the regulator does not start.

### Soft-Start

Once SS has charged to 0.8V (T0.8), the output voltage is in regulation. Until SS reaches 1.0V (T1.0), the "Fault Latch" and power-saving mode operations are inhibited.

To avoid skipping the soft-start cycle, it is necessary to apply  $V_{IN}$  before  $V_{CC}$  reaches its UVLO threshold.

Soft-start time is a function of oscillator frequency.

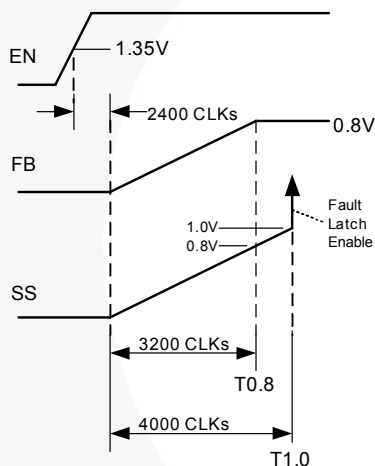

Figure 21. Soft-Start Timing Diagram

The regulator does not allow the low-side MOSFET to operate in full synchronous rectification mode until SS reaches 95% of  $V_{REF}$  (~0.76V). This helps the regulator start against pre-biased outputs and ensures that inductor current does not "ratchet" up during the soft-start cycle.

$V_{CC}$  UVLO or toggling the EN pin discharges the SS and resets the IC.

### Bias Supply

The FAN2103 requires a 5V supply rail to bias the IC and provide gate-drive energy and controller power. Connect a  $\geq 1.0\mu f$  X5R or X7R decoupling capacitor between  $V_{CC}$  and PGND. Whenever EN pin is pulled up to  $V_{CC}$ , the 5V supply connected to  $V_{CC}$  should be turned ON after  $V_{IN}$  comes up. If the power supply is turned ON using EN pin with an external control after  $V_{CC}$  and  $V_{IN}$  come up, the  $V_{CC}$  and  $V_{IN}$  power sequencing is not relevant.

Since  $V_{CC}$  is used to drive the internal MOSFET gates, supply current is frequency and voltage dependent. Approximate  $V_{CC}$  current ( $I_{CC}$ ) can be calculated using:

$$I_{CC(mA)} = 4.58 + \left[ \left( \frac{V_{CC} - 5}{227} + 0.013 \right) \cdot (F - 128) \right] \quad (1)$$

where frequency (F) is expressed in KHz.

### Setting the Output Voltage

The output voltage of the regulator can be set from 0.8V to ~90% of  $V_{IN}$  by an external resistor divider (R1 and  $R_{BIAS}$  in Figure 1).

The internal reference is 0.8V with 650nA, sourced from the FB pin to ensure that if the pin is open, the regulator does not start.

The external resistor divider is calculated using:

$$\frac{0.8V}{R_{BIAS}} = \frac{V_{OUT} - 0.8V}{R1} + 650nA \quad (2)$$

Connect  $R_{BIAS}$  between FB and AGND.

To minimize noise on the FB node, the values of R1 and  $R_{BIAS}$  should be selected to provide a minimum parallel impedance of  $1K\Omega$ .

### Setting the Frequency

Oscillator frequency is determined by an external resistor,  $R_T$ , connected between the R(T) pin and AGND:

$$F_{(KHz)} = \frac{10^6}{(65 \cdot R_T) + 135} \quad (3)$$

where  $R_T$  is expressed in  $K\Omega$ .

$$R_{T(K\Omega)} = \frac{(10^6 / F) - 135}{65} \quad (4)$$

where frequency (F) is expressed in KHz.

The regulator does not start if  $R_T$  is left open.

### Calculating the Inductor Value

Typically the inductor is set for a ripple current ( $\Delta I_L$ ) of 10% to 35% of the maximum DC load. Regulators requiring fast transient response use a value on the high side of this range, while regulators that require very low output ripple and/or use high-ESR capacitors restrict allowable ripple current:

$$\Delta I_L = \frac{V_{OUT} \cdot (1 - D)}{L \cdot F} \quad (5)$$

where F is the oscillator frequency, and

$$L = \frac{V_{OUT} \cdot (1 - D)}{\Delta I_L \cdot F} \quad (6)$$

The selection of inductor influences the entry into power-saving mode. Consider minimum and maximum load conditions before inductor selection.

### Setting the Ramp Resistor Value

The internal ramp voltage excursion ( $\Delta V_{RAMP}$ ) during  $t_{ON}$  should be set to 0.6V.  $R_{RAMP}$  is approximately:

$$R_{RAMP(K\Omega)} = \frac{(V_{IN} - 1.8) \cdot V_{OUT}}{18 \times 10^{-6} \cdot V_{IN} \cdot F} - 2 \quad (7)$$

where frequency (F) is expressed in KHz.

### Setting the Current Limit

There are two levels of current limit thresholds in FAN2103. The first level of protection is through an internal default limit set at the factory to limit output current beyond normal usage levels. The second level of protection is a flexible one to be set externally by the user. Current limit protection is enabled whenever the lower of the two thresholds is reached. The FAN2103 uses its internal low-side MOSFET as the current-sensing element. The current-limit threshold voltage ( $V_{ILIM}$ ) is compared to the voltage drop across the low-side MOSFET, sampled at the end of each PWM off-time/cycle. The internal default threshold (with  $I_{LIM}$  open) is temperature compensated.

The 10 $\mu$ A current sourced from the ILIM pin can be used to establish a lower, temperature-dependent, current-limit threshold by connecting an external resistor ( $R_{ILIM}$ ) to AGND:

$$R_{ILIM(K\Omega)} = 10.4 \cdot K_T \cdot (I_{OUT} - \frac{\Delta I_L}{2}) + 142.5 \quad (8)$$

where:

- $I_{OUT}$  = desired current limit set point in Amps,
- $K_T$  = the normalized temperature coefficient of the low-side MOSFET (Q2) from Figure 8.

After 16 consecutive, pulse-by-pulse, current-limit cycles, the fault latch is set and the regulator shuts down. Cycling  $V_{CC}$  or EN restores operation after a normal soft-start cycle (refer to *Auto-Restart* section).

The over-current protection fault latch is active during the soft-start cycle. Use a 1% resistor for  $R_{ILIM}$ .

### Loop Compensation

The loop is compensated using a feedback network around the error amplifier. Figure 22 shows a complete Type-3 compensation network. Type-2 compensation eliminates R3 and C3.

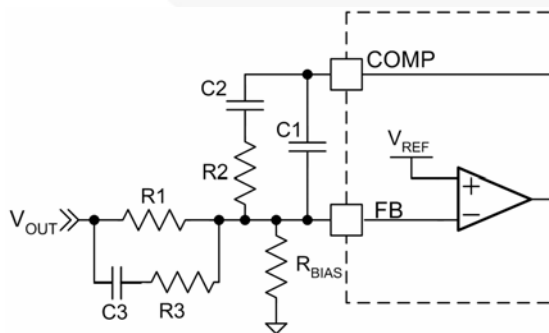

Figure 22. Compensation Network

Because the FAN2103 employs summing current-mode architecture, Type-2 compensation can be used for many applications. For applications that require wide loop bandwidth and/or use very low-ESR output capacitors, Type-3 compensation may be required.

$R_{RAMP}$  provides feedforward compensation for changes in  $V_{IN}$ . With a fixed  $R_{RAMP}$  value, the modulator gain increases as  $V_{IN}$  is reduced, which could make it difficult to compensate the loop. For designs with low input voltages (3V to 6.5V), it is recommended that separate  $R_{RAMP}$  and the compensation component values are used as compared to designs with  $V_{IN}$  between 6.5V and 24V.

### Protection

The converter output is monitored and protected against extreme overload, short-circuit, over-voltage, and under-voltage conditions.

An internal "Fault Latch" is set for any fault intended to shut down the IC. When the fault latch is set, the IC discharges  $V_{OUT}$  by enhancing the low-side MOSFET until  $FB < 0.25V$ . The MOSFET is not turned on again unless  $FB > 0.5V$ . This behavior discharges the output without causing undershoot (negative output voltage).

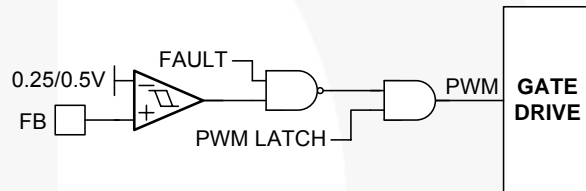

Figure 23. Latched Fault Response

### Under-Voltage Shutdown

If FB remains below the under-voltage threshold for 16 consecutive clock cycles, the fault latch is set and the converter shuts down. This fault is prevented from setting the fault latch during soft-start.

### Over-Voltage Protection / Shutdown

If FB exceeds  $115\% \cdot V_{REF}$  for two consecutive clock cycles, the fault latch is set and shutdown occurs.

A shorted high-side MOSFET condition is detected when SW voltage exceeds  $\sim 0.7V$  while the low-side MOSFET is fully enhanced. The fault latch is set immediately upon detection.

These two fault conditions are allowed to set the fault latch at any time, including during soft-start.

### Auto-Restart

After a fault, EN is discharged with 1 $\mu$ A to a 1.1V threshold before the 800K $\Omega$  pull-up is restored. A new soft-start cycle begins when EN charges above 1.35V.

Depending on the external circuit, the FAN2103 can be provisioned to remain latched-off or automatically restart after a fault.

**Table 1. Fault / Restart Provisioning**

|                 |  |
|-----------------|--|
| EN pin          | Controller / Restart State   |
| Pull to GND     | OFF (disabled)   |
| V <sub>CC</sub> | No restart – latched OFF   |
| Open            | Immediate restart after fault  |
| Cap to GND      | New soft-start cycle after:<br>$t_{DELAY} \text{ (msec)} = 3.9 \cdot C \text{ (nf)}$ |

With EN left open, restart is immediate.

If auto-restart is not desired, tie the EN pin to the V<sub>CC</sub> pin or drive it with a logic gate to keep the 1μA current sink from discharging EN to 1.1V.

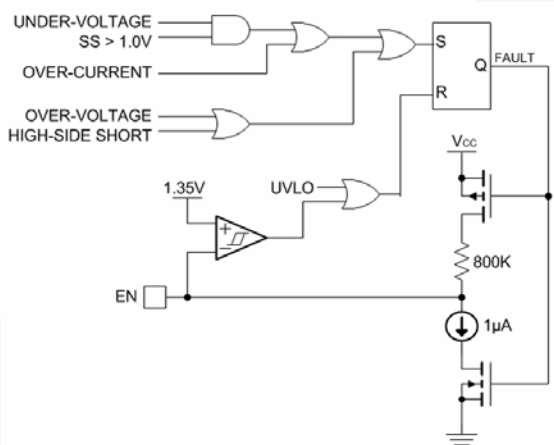

**Figure 24. Fault Latch with Delayed Auto-Restart**

### Over-Temperature Protection

FAN2103 incorporates an over-temperature protection circuit that sets the fault latch when a die temperature of about 160°C is reached. The IC is allowed to restart when the die temperature falls below 130°C.

### Power Good (PGOOD) Signal

PGOOD is an open-drain output that asserts LOW when V<sub>OUT</sub> is out of regulation, as measured at the FB pin (thresholds are specified in the Electrical Specifications section). PGOOD does not assert HIGH until the fault latch is enabled (T1.0).

### Power-Saving Mode

The FAN2103 maintains high efficiency at light load by changing to a discontinuous, constant peak current, power-saving mode (PSM).

The transition to power-saving mode occurs when the load is  $\leq \Delta I_L / 2$  for eight consecutive clock cycles.

In power-saving mode, a constant-peak inductor current ( $\Delta I_{LPSM}$ ) is generated each on-cycle.  $\Delta I_{LPSM}$  is nominally 85% larger than PWM-mode inductor ripple ( $\Delta I_L$ ).

During power-saving mode, the output is regulated to a slightly higher value than its set point, since the current pulse is triggered when FB crosses V<sub>REF</sub>.

The IC is prevented from switching in the audible band. If the FB pin has not dropped to V<sub>REF</sub> within 40μs of the last pulse, the IC sinks current through the inductor to initiate a new cycle.

Transition back to PWM mode is achieved when a load transient causes the output voltage to drop 1.5% below its regulation point.

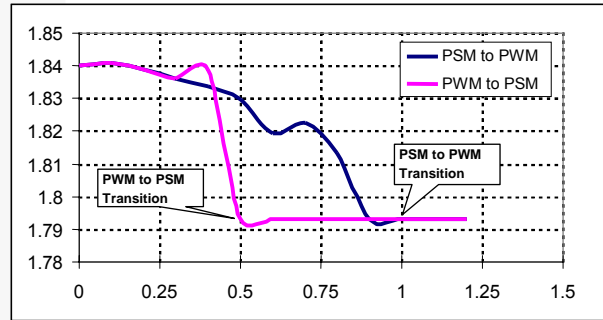

**Figure 25. Power-Saving Mode Regulation**  
(Using Figure 10 Circuit)

Power-saving mode operation can be disabled by connecting the PWM# pin to AGND, allowing only PWM operation. The PWM# pin has a 1μA pull-down. If <0.6V is detected, power-saving mode operation is disabled.

### PCB Layout

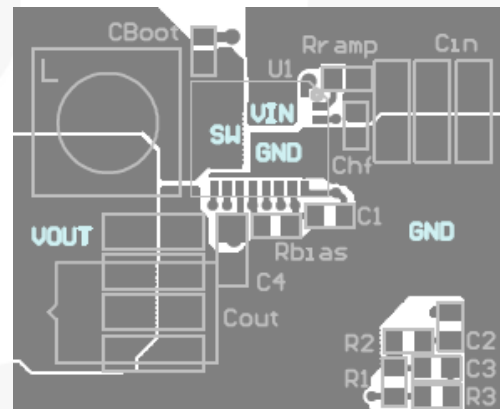

**Figure 26. Recommended PCB Layout**

## Physical Dimensions

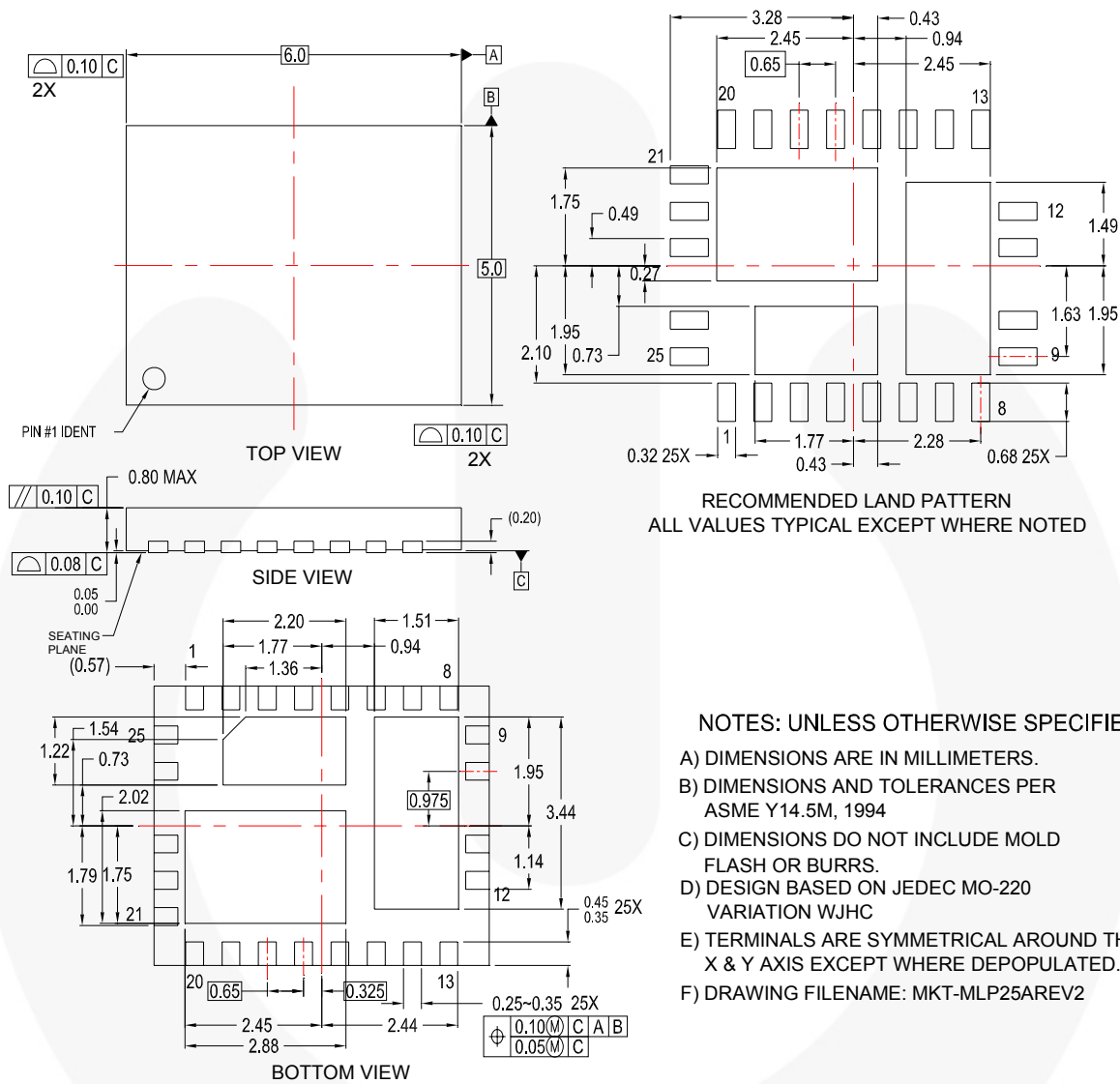

Figure 27. 5x6mm Molded Leadless Package (MLP)

Package drawings are provided as a service to customers considering Fairchild components. Drawings may change in any manner without notice. Please note the revision and/or date on the drawing and contact a Fairchild Semiconductor representative to verify or obtain the most recent revision. Package specifications do not expand the terms of Fairchild's worldwide terms and conditions, specifically the warranty therein, which covers Fairchild products.



Always visit Fairchild Semiconductor's online packaging area for the most recent package drawings:

<http://www.fairchildsemi.com/packaging/>



**TRADEMARKS**

The following includes registered and unregistered trademarks and service marks, owned by Fairchild Semiconductor and/or its global subsidiaries, and is not intended to be an exhaustive list of all such trademarks.

- |   |  |  |                                  |
|---|--|--|----------------------------------|
| ACEx <sup>®</sup>   | FPS <sup>™</sup>                             | PDP-SPM <sup>™</sup>                   | SyncFET <sup>™</sup>             |
| Build it Now <sup>™</sup>   | FRFET <sup>®</sup>                           | Power220 <sup>®</sup>                  | SYSTEM <sup>®</sup>              |
| CorePLUS <sup>™</sup>   | Global Power Resource <sup>SM</sup>          | Power247 <sup>®</sup>                  | GENERAL <sup>®</sup>             |
| CROSSVOL <sup>™</sup>   | Green FPS <sup>™</sup>                       | POWEREDGE <sup>®</sup>                 | The Power Franchise <sup>®</sup> |
| CTL <sup>™</sup>  | Green FPS <sup>™</sup> e-Series <sup>™</sup> | Power-SPM <sup>™</sup>                 | <b>the power franchise</b>       |
| Current Transfer Logic <sup>™</sup>   | GTO <sup>™</sup>                             | PowerTrench <sup>®</sup>               | TinyBoost <sup>™</sup>           |
| EcoSPARK <sup>®</sup>   | i-Lo <sup>™</sup>                            | Programmable Active Droop <sup>™</sup> | TinyBuck <sup>™</sup>            |
| EZSWITCH <sup>™</sup> *   | IntelliMAX <sup>™</sup>                      | QFET <sup>®</sup>                      | TinyLogic <sup>®</sup>           |
|  ™ | ISOPLANAR <sup>™</sup>                       | QS <sup>™</sup>                        | TINYOPTO <sup>™</sup>            |
|  ™ | MegaBuck <sup>™</sup>                        | QT Optoelectronics <sup>™</sup>        | TinyPower <sup>™</sup>           |
| Fairchild <sup>®</sup>  | MICROCOUPLER <sup>™</sup>                    | Quiet Series <sup>™</sup>              | TinyPWM <sup>™</sup>             |
| Fairchild Semiconductor <sup>®</sup>  | MicroFET <sup>™</sup>                        | RapidConfigure <sup>™</sup>            | TinyWire <sup>™</sup>            |
| FACT Quiet Series <sup>™</sup>  | MicroPak <sup>™</sup>                        | SMART START <sup>™</sup>               | μSerDes <sup>™</sup>             |
| FACT <sup>®</sup>   | MillerDrive <sup>™</sup>                     | SPM <sup>®</sup>                       | UHC <sup>®</sup>                 |
| FAST <sup>®</sup>   | Motion-SPM <sup>™</sup>                      | STEALTH <sup>™</sup>                   | Ultra FRFET <sup>™</sup>         |
| FastvCore <sup>™</sup> *  | OPTOLOGIC <sup>®</sup>                       | SuperFET <sup>™</sup>                  | UniFET <sup>™</sup>              |
| FlashWriter <sup>®</sup> *  | OPTOPLANAR <sup>®</sup>                      | SuperSOT <sup>™</sup> -3               | VCX <sup>™</sup>                 |
|   |  | SuperSOT <sup>™</sup> -6               |                                  |
|   |  | SuperSOT <sup>™</sup> -8               |                                  |

\* EZSWITCH<sup>™</sup> and FlashWriter<sup>®</sup> are trademarks of System General Corporation, used under license by Fairchild Semiconductor.

**DISCLAIMER**

FAIRCHILD SEMICONDUCTOR RESERVES THE RIGHT TO MAKE CHANGES WITHOUT FURTHER NOTICE TO ANY PRODUCTS HEREIN TO IMPROVE RELIABILITY, FUNCTION, OR DESIGN. FAIRCHILD DOES NOT ASSUME ANY LIABILITY ARISING OUT OF THE APPLICATION OR USE OF ANY PRODUCT OR CIRCUIT DESCRIBED HEREIN; NEITHER DOES IT CONVEY ANY LICENSE UNDER ITS PATENT RIGHTS, NOR THE RIGHTS OF OTHERS. THESE SPECIFICATIONS DO NOT EXPAND THE TERMS OF FAIRCHILD'S WORLDWIDE TERMS AND CONDITIONS, SPECIFICALLY THE WARRANTY THEREIN, WHICH COVERS THESE PRODUCTS.

**LIFE SUPPORT POLICY**

FAIRCHILD'S PRODUCTS ARE NOT AUTHORIZED FOR USE AS CRITICAL COMPONENTS IN LIFE SUPPORT DEVICES OR SYSTEMS WITHOUT THE EXPRESS WRITTEN APPROVAL OF FAIRCHILD SEMICONDUCTOR CORPORATION.

As used herein:

1. Life support devices or systems are devices or systems which, (a) are intended for surgical implant into the body or (b) support or sustain life, and (c) whose failure to perform when properly used in accordance with instructions for use provided in the labeling, can be reasonably expected to result in a significant injury of the user.
2. A critical component in any component of a life support, device, or system whose failure to perform can be reasonably expected to cause the failure of the life support device or system, or to affect its safety or effectiveness.

**PRODUCT STATUS DEFINITIONS**

**Definition of Terms**

| Datasheet Identification | Product Status         | Definition   |
|--------------------------|------------------------|--|
| Advance Information      | Formative or In Design | This datasheet contains the design specifications for product development. Specifications may change in any manner without notice.   |
| Preliminary              | First Production       | This datasheet contains preliminary data; supplementary data will be published at a later date. Fairchild Semiconductor reserves the right to make changes at any time without notice to improve design. |
| No Identification Needed | Full Production        | This datasheet contains final specifications. Fairchild Semiconductor reserves the right to make changes at any time without notice to improve the design.   |
| Obsolete                 | Not In Production      | This datasheet contains specifications on a product that has been discontinued by Fairchild Semiconductor. The datasheet is printed for reference information only.                                      |

Rev. 132