

White LED Step-Up Converter In Tiny SOT-23 Package

DESCRIPTION

The EUP2571 is a constant current step-up converter specifically designed to drive white LEDs. The Step-up converter topology allows series connection of the white LEDs so the LED currents are identical for uniform brightness. The EUP2571 switches at 1.1MHz, allowing the use of tiny external components. The input and output capacitor can be as small as 1 μ F, saving space and cost versus alternative solutions. A low 0.25V feedback voltage minimizes power loss in the current setting resistor for better efficiency.

The EUP2571 is available in low profile SOT23-5, SOT23-6 package.

FEATURES

- 2.6V to 5.5V Input Range
- 26V Output with Over Voltage Protection
- High Efficiency :85 % Typical
- PWM Dimming Control
- Internal High Power 30V MOSFET Switch
- Fast 1.1MHz Switching Frequency
- Small, Low-Profile Inductors and Capacitors
- SOT23-5,SOT23-6 Package
- RoHS Compliant and 100% Lead (Pb)-Free

APPLICATIONS

- Mobile Phone
- Digital Still Camera
- PDAs, Handheld Computers
- MP3 Players
- GPS Receivers

Typical Application Circuit

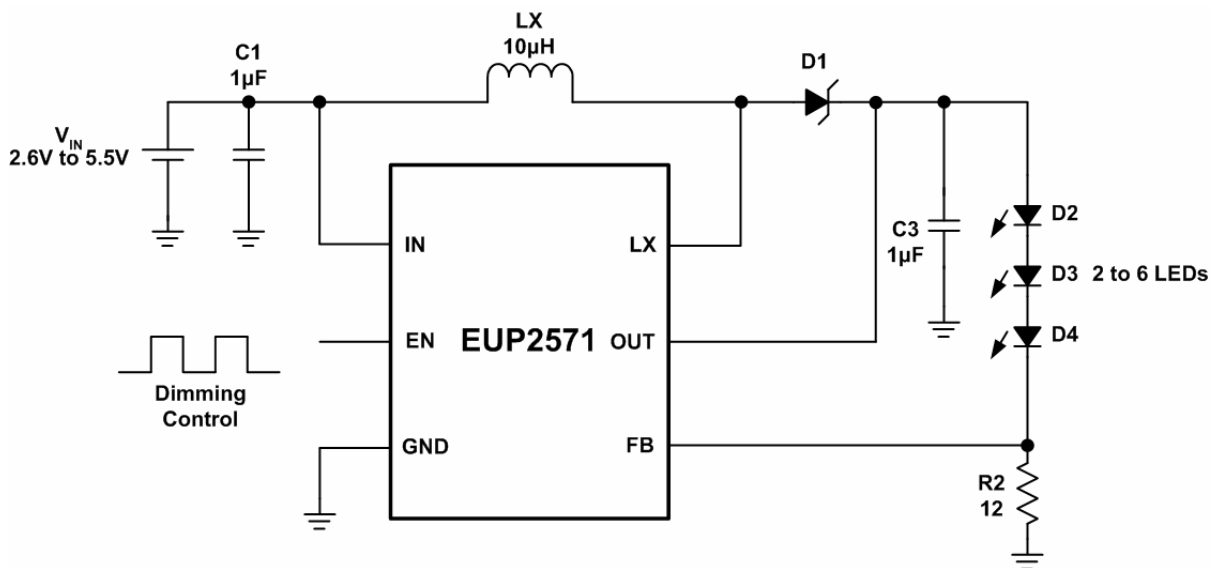

Figure 1. White LED Application

Typical Application Circuit (continued)

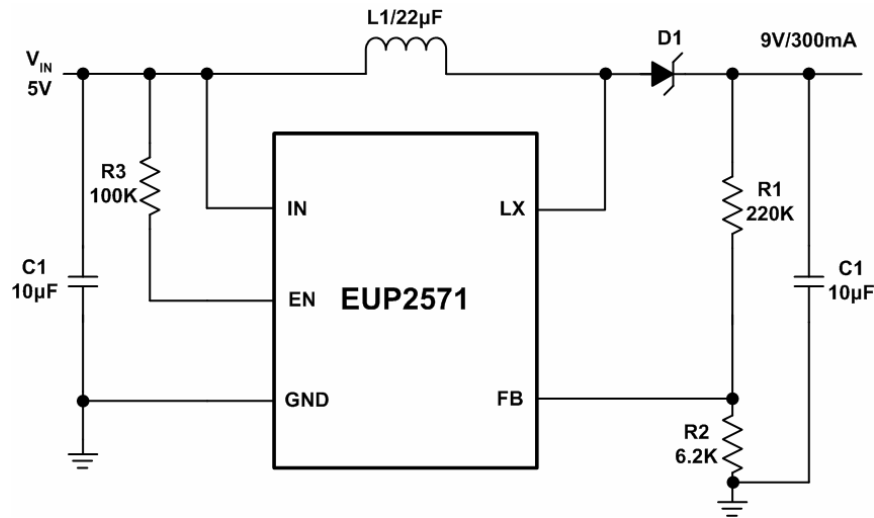

Figure 2. 5V to 9V/300mA Step-Up Application

Pin Configurations

Package Type	Pin Configurations	Package Type	Pin Configurations
SOT23-5		SOT23-6	

Pin Description

PIN	SOT23-5	SOT23-6	DESCRIPTION
LX	1	1	Switch Pin. Connect inductor/diode here. Minimize trace area at this pin to reduce EMI.
GND	2	2	Common Ground
FB	3	3	Feedback Pin. Reference voltage is 0.25V. Connect cathode of lowest LED and resistor here. Calculate resistor value according to the formula: $R_{FB}=0.25/I_{LED}$
EN	4	4	Chip Enable Pin. Connect to 1.4V or higher to enable device, 0.4V or less to disable device.
IN	5	6	Input Supply Voltage
OUT	-	5	Overvoltage Sense. When V_{OUT} is greater than 27V, the internal N-channel MOSFET turns off until V_{OUT} drops below 25V, then the IC reenters start. Connect a 1uF capacitor from OUT to GND.

Ordering Information

Order Number	Package Type	Marking	Operating Temperature range
EUP2571VBIR1	SOT23-5	V0	-40 °C to 125°C
EUP2571VCIR1	SOT23-6	V0	-40 °C to 125°C

EUP2571

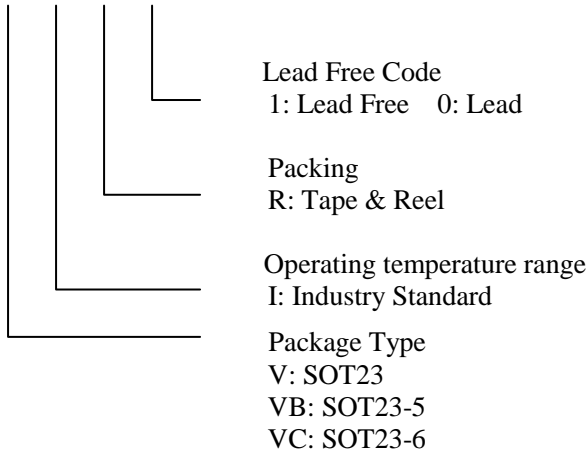

Block Diagram

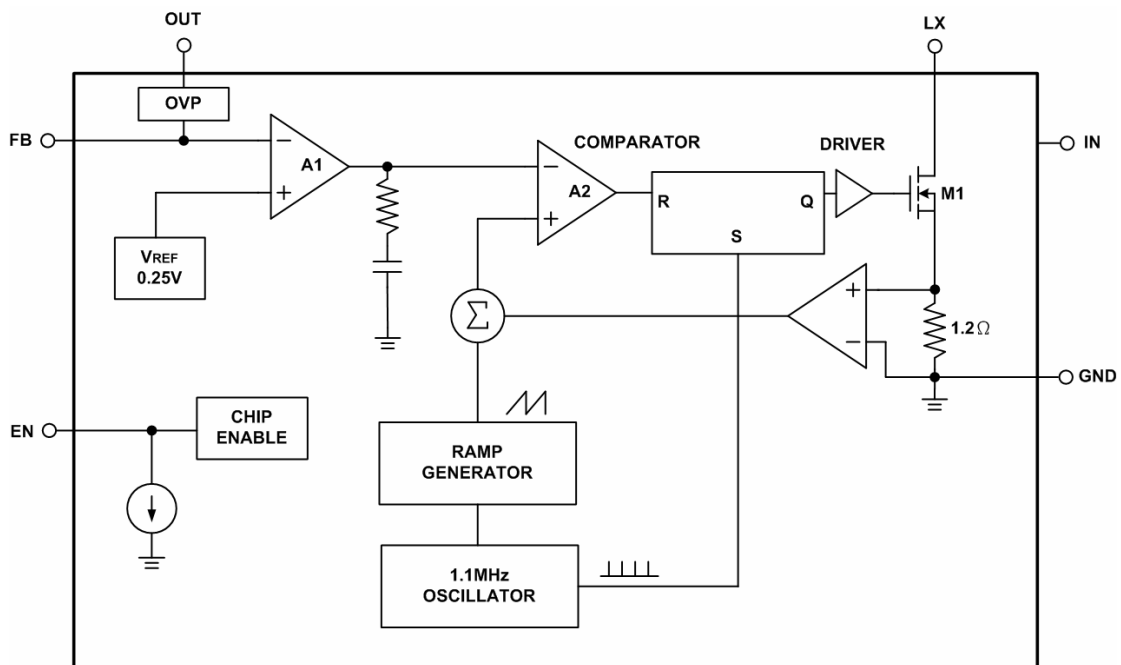

Figure 3.

Absolute Maximum Ratings

- Supply Voltage , V_{IN} ----- -0.3V to 6V
- LX,OUT ----- -0.3V to 30V
- The Other Pins ----- -0.3V to 6V
- Power dissipation, P_D @ $T_A=25^{\circ}C$
SOT23-6 ----- 0.4W
- Package Thermal Resistance
SOT23-6, J_A ----- 250°C/W
- Maximum Junction Temperature ----- 125°C
- Lead Temperature (Soldering, 10sec.) ----- 260°C
- Storage Temperature Range ----- -65°C to 150°C

Operating Conditions

- Junction Temperature Range ----- -40°C to 125°C
- Supply Voltage , V_{IN} ----- 2.6V to 5.5V

Electrical Characteristics

($V_{IN}=3.6V$, $V_{OUT}=12V$, $C_{OUT}=1\mu F$, $C_{IN}=1\mu F$, $R_{SENSE}=12$, $T_A=-40^{\circ}C$ to $85^{\circ}C$. Unless otherwise noted.
Typical values are at $T_A=25^{\circ}C$)

Symbol	Parameter	Conditions	EUP2571			Unit
			Min	Typ	Max.	
	Supply Voltage		--	--	6	V
UVLO	Under voltage Lock Out	V_{IN} rising or falling	2.2	2.4	2.6	V
	Maximum Output Voltage		--	--	26	V
I_{CC1}	Supply Current	$V_{CC}=6V$, Continuous Switching	--	0.8	1.5	mA
I_{CC2}	Quiescent Current	$V_{CC}=6V$, $FB=1.3V$, No Switching	--	115	250	μA
I_{CC3}	Shut Down current	$V_{CC}=6V$, $V_{EN}<0.4V$	--	0.1	1	μA
Oscillator						
Fosc	Operation Frequency		0.8	1.1	1.3	MHz
Dmax	Maximum Duty Cycle		89	92	96	%
Reference Voltage						
V_{FB}	Feedback Voltage	$T_A=25$	237	250	263	mV
		$T_A=-40^{\circ}C$ to $85^{\circ}C$	230	250	270	
MOSFET						
Rds (on)	On resistance of MOSFET		--	1.05	1.5	
ILX	Current Limit		0.4	0.75	1.2	A
Control and Protection						
V_{EN1}	Shut Down Voltage		0.4	0.7	--	V
V_{EN2}	Enable Voltage		--	0.7	1.2	V
I_{EN}	EN Pin Pull Low Current		--	--	0.1	μA
OVP	OVP Threshold	Falling	24.5	25.7	26.5	V
		Rising	26.1	27.3	28.1	

Typical Operating Characteristics

Efficiency vs. Vin (Driving 1WLED)

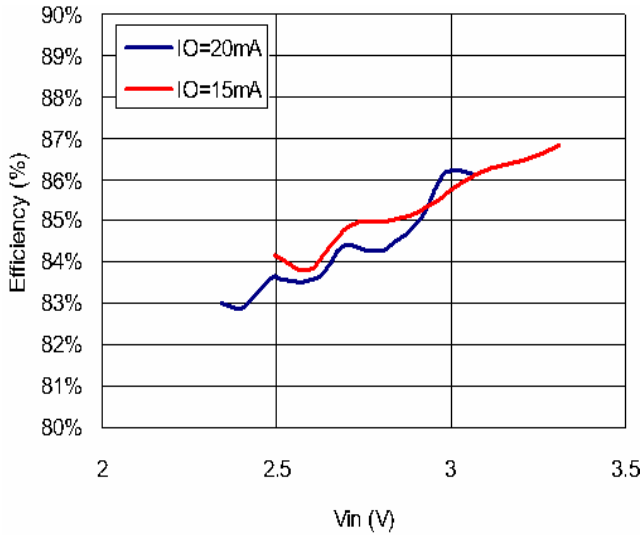

Efficiency vs. Vin (Driving 2WLEDs)

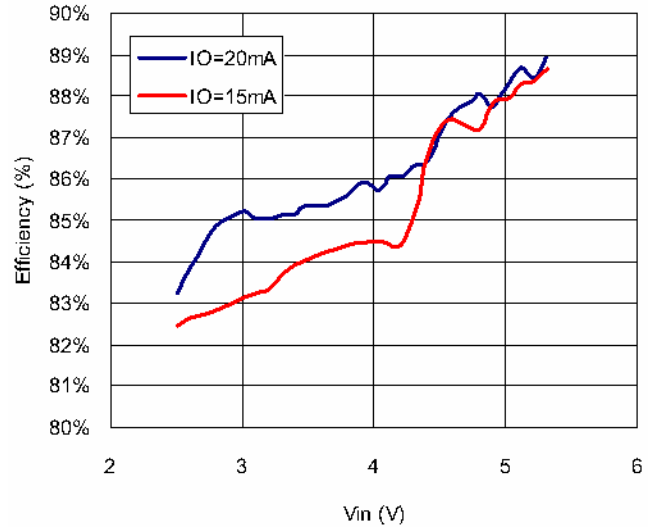

Efficiency vs. Vin (Driving 3WLEDs)

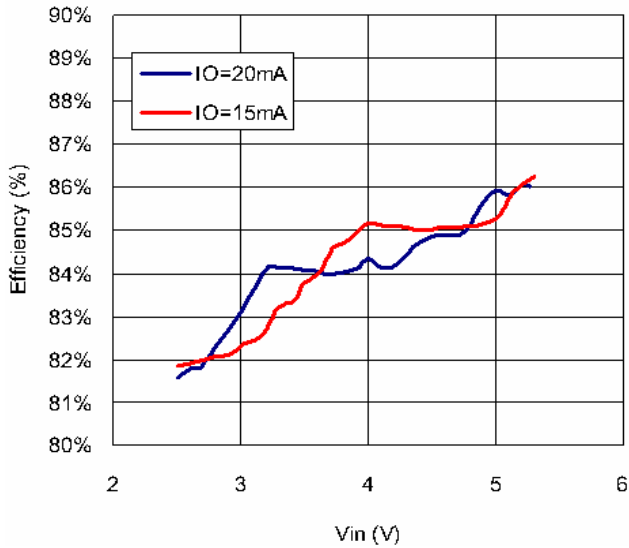

Efficiency vs. Vin (Driving 5WLEDs)

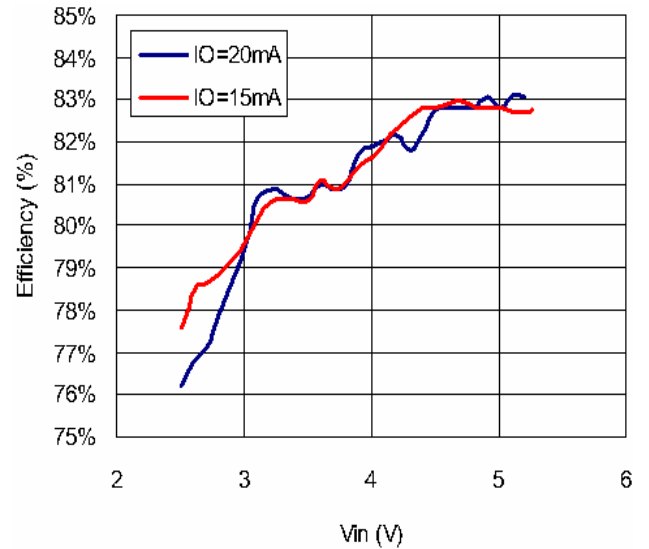

Efficiency vs. Vin (Driving 7WLEDs)

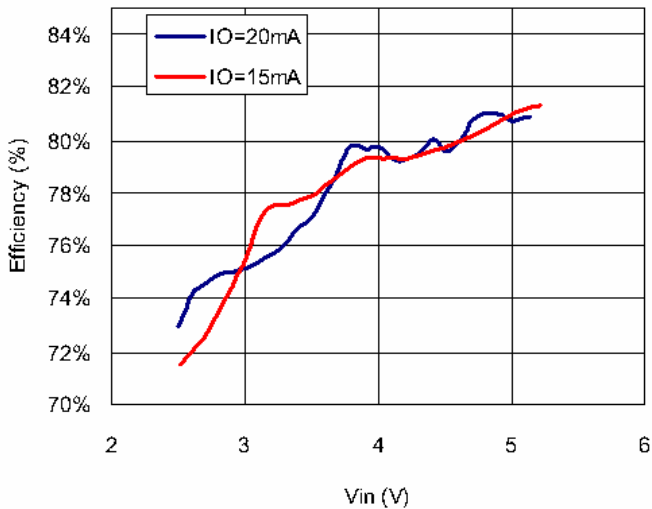

Stability for Driving 1 WLED

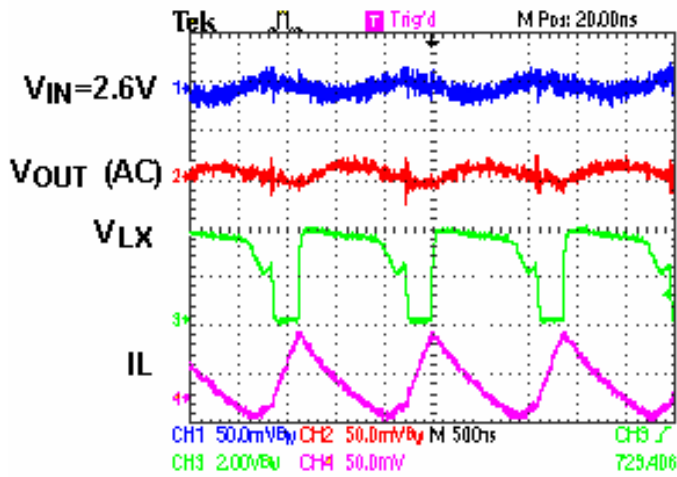

Stability for Driving 5 WLEDs

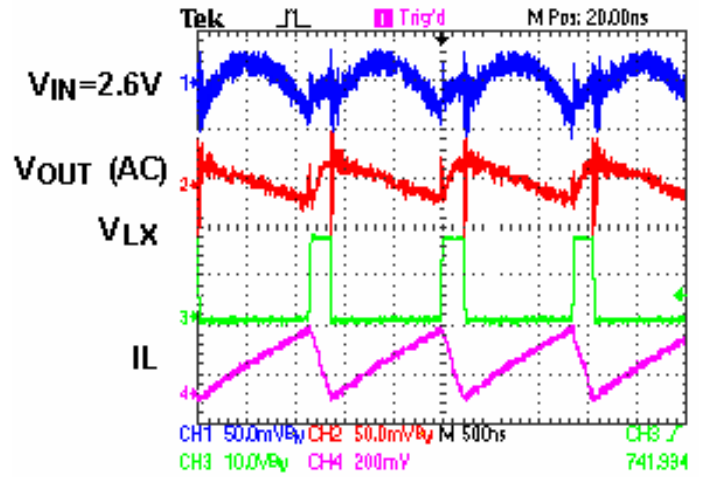

Stability for Driving 1 WLED

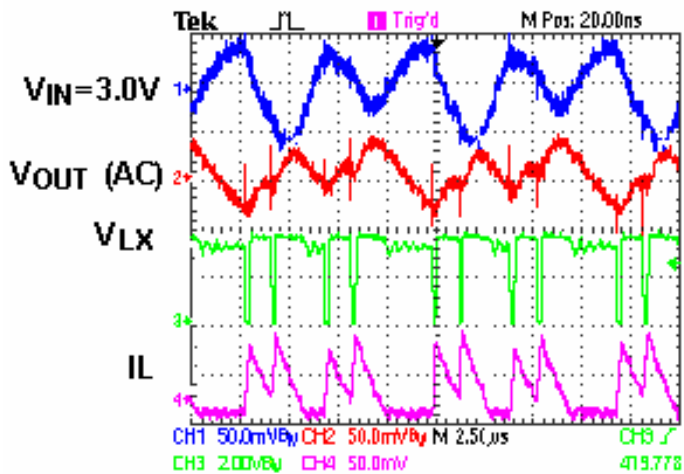

Stability for Driving 5 WLEDs

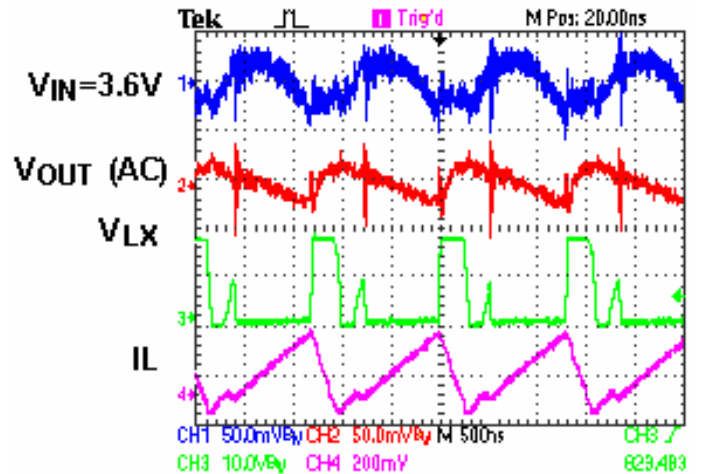

Stability for Driving 2 WLEDs

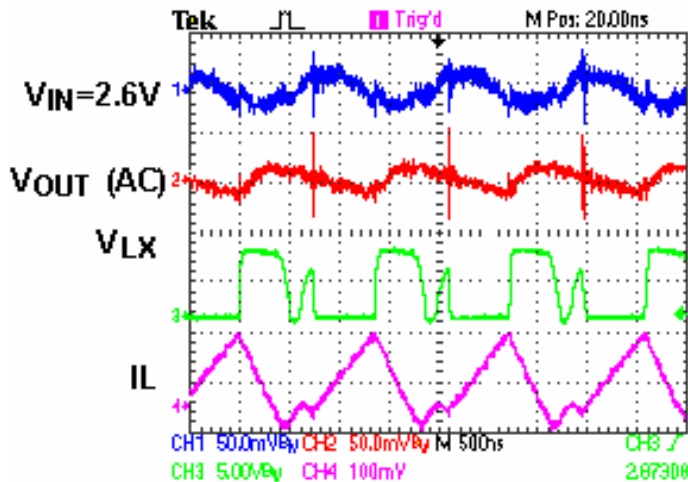

Stability for Driving 5 WLEDs

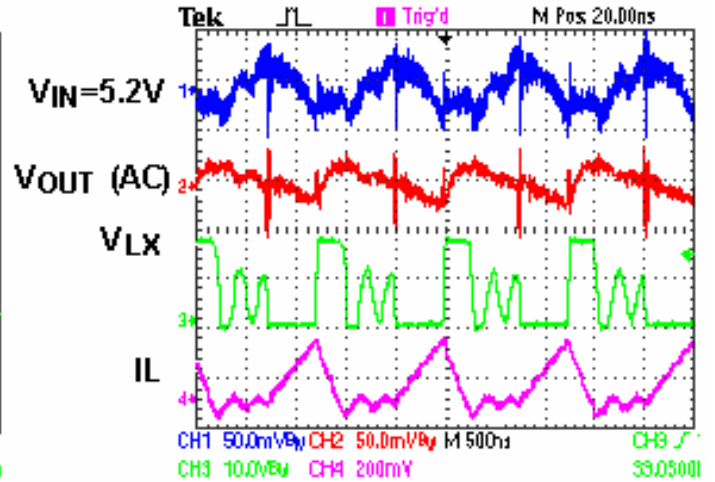

Stability for Driving 2 WLEDs

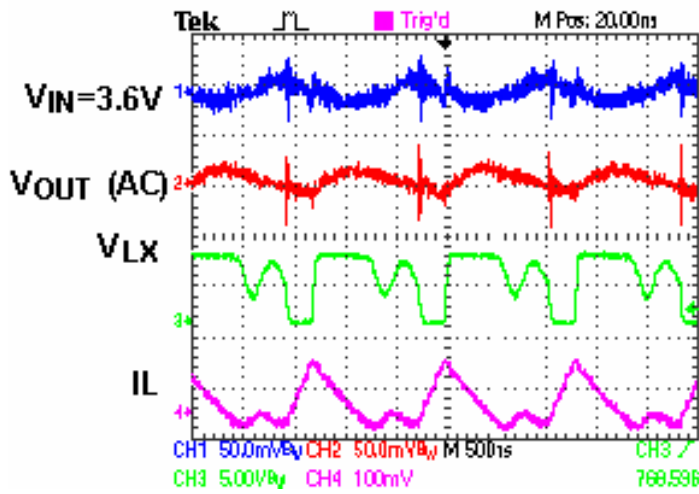

Stability for Driving 7 WLEDs

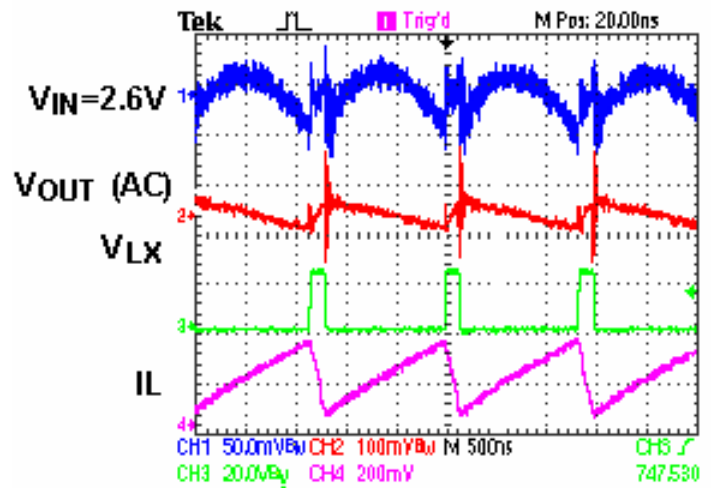

Stability for Driving 2 WLEDs

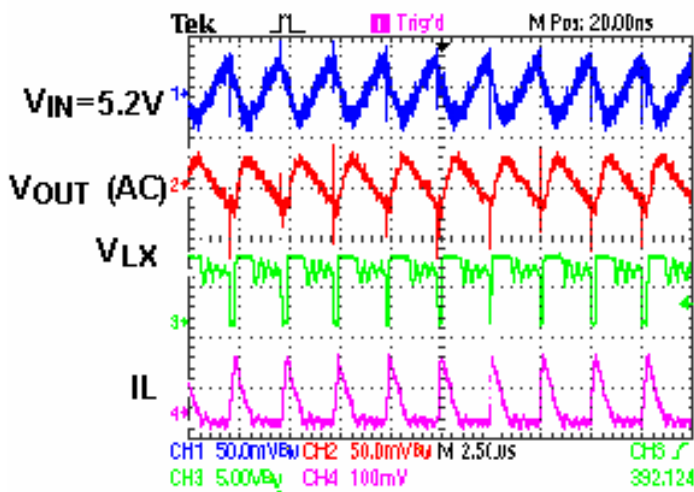

Stability for Driving 7 WLEDs

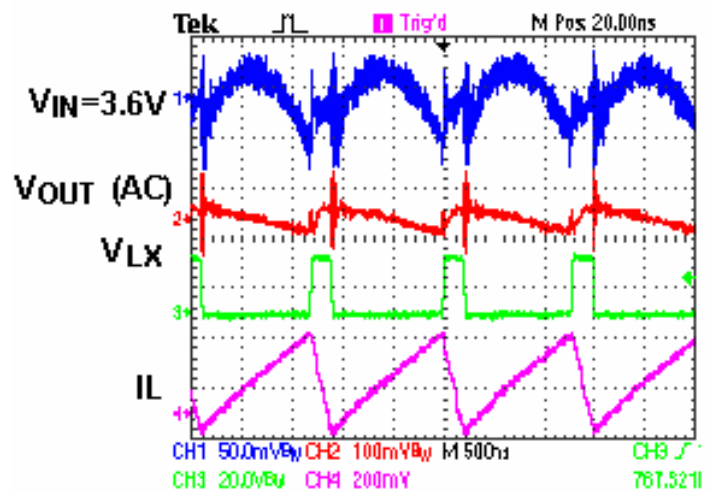

Stability for Driving 3 WLEDs

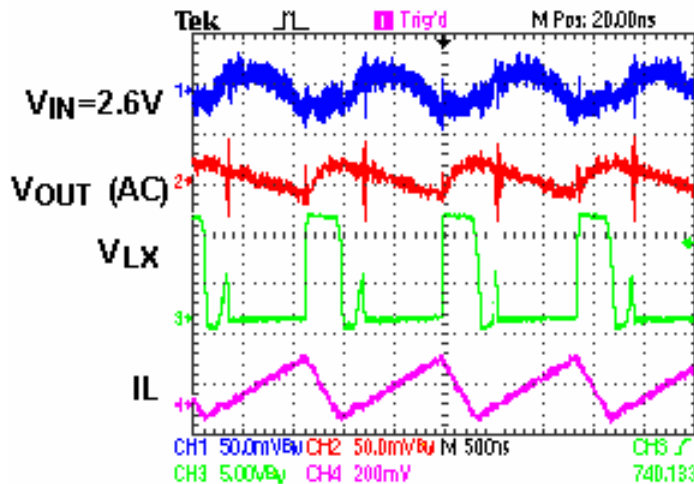

Stability for Driving 7 WLEDs

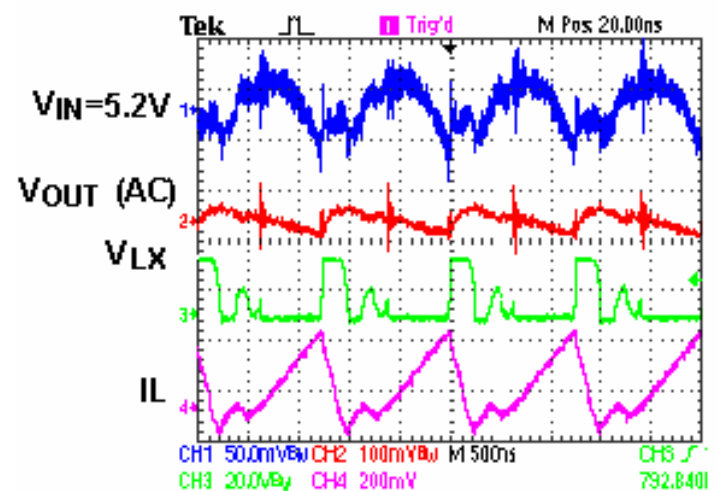

Stability for Driving 3 WLEDs

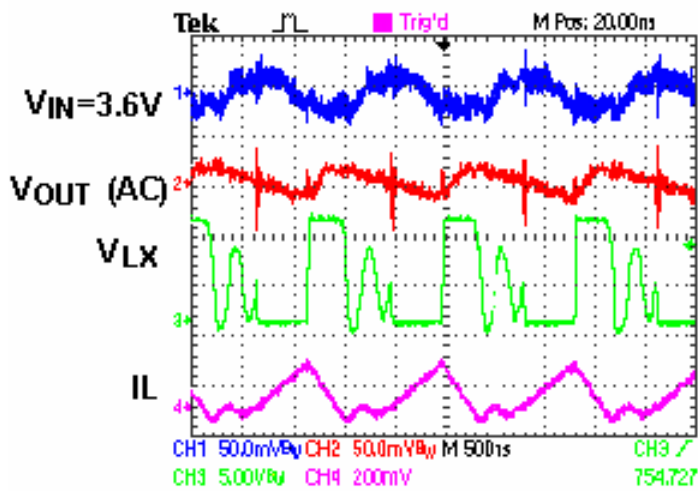

Stability for Driving 3 WLEDs

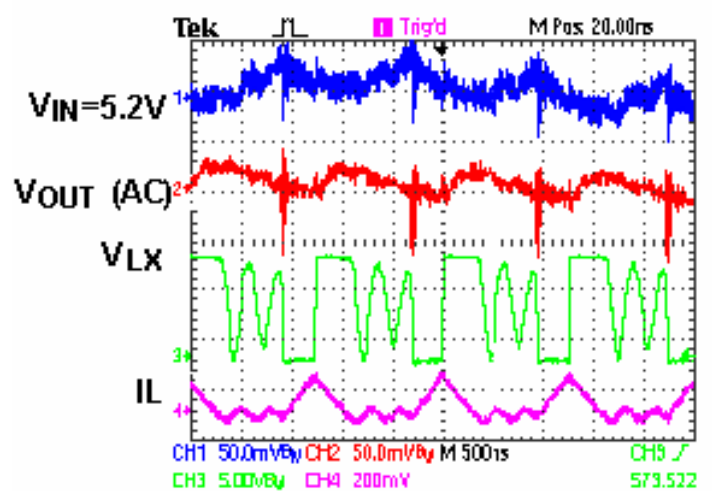

Duty Cycle vs. Load Current (PWM at EN)

V_{IN} = 3.6V

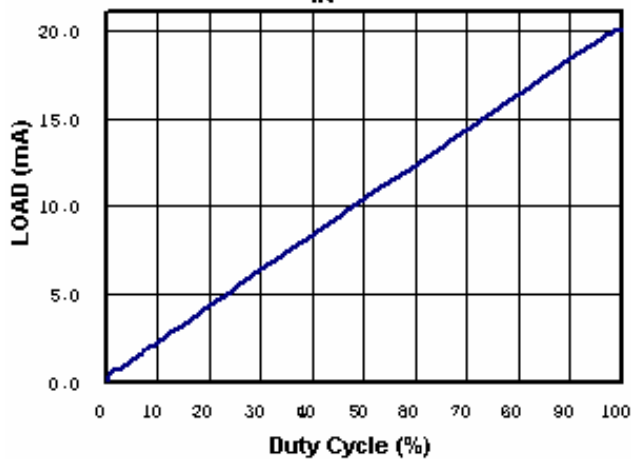

Inrush Current for Driving 1 WLED

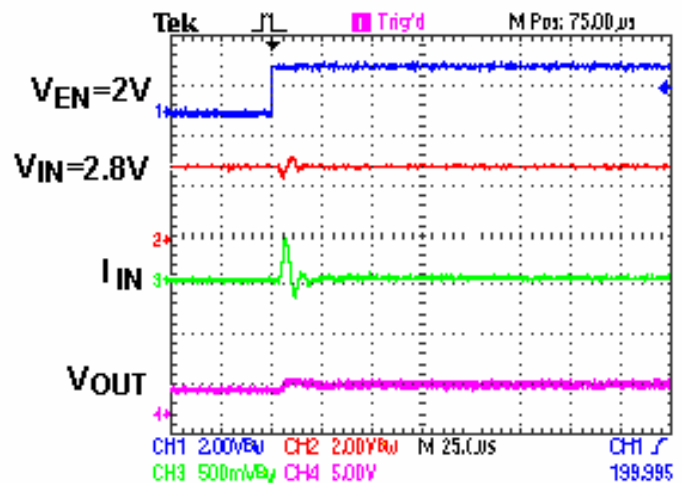

Inrush Current for Driving 2 WLEDs

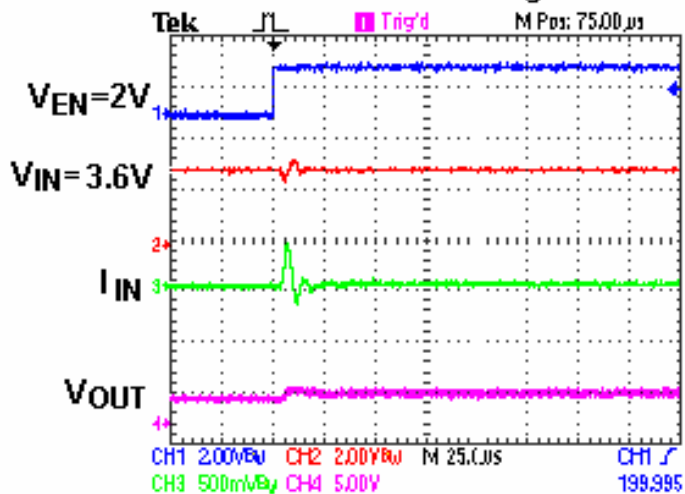

Inrush Current for Driving 3 WLEDs

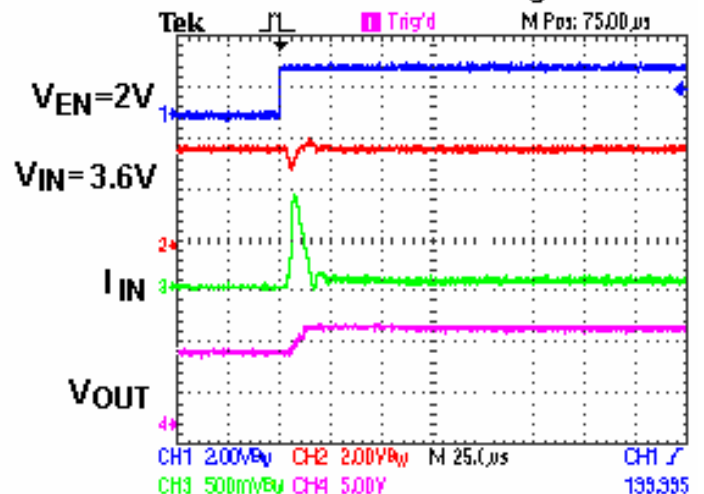

Inrush Current for Driving 5 WLEDs

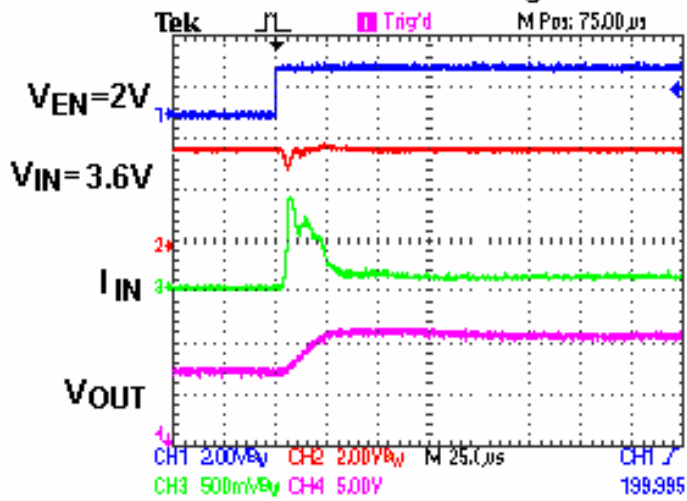

Inrush Current for Driving 7 WLEDs

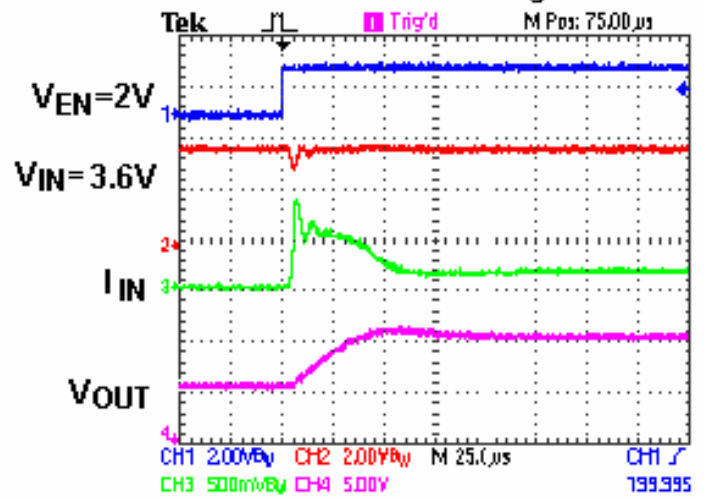

Dimming Control for Driving 3 WLEDs

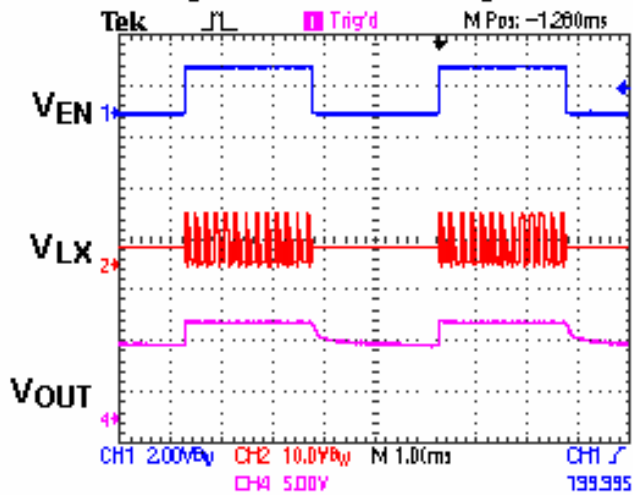

Application Information

LED Current Control

The EUP2571 regulates the LED current by setting the current sense resistor (R2) connecting to feedback and ground. The internal feedback reference voltage is 0.25V. The LED current can be set from following equation easily.

$$R2 = 0.25V / I_{LED} \text{-----(1)}$$

In order to have an accurate LED current, precision resistors are preferred (1% is recommended). The table for R2 selection is shown below.

R2 Resistor Value selection	
I _{LED} (mA)	R2 (Ω)
5	49.9
10	24.9
12	21
15	16.5
20	12.4

Inductor Selection

The recommended value of inductor for 2 to 6 WLEDs applications are 4.7 to 22μH. Small size and better efficiency are the major concerns for portable device, such as EUP2571 used for mobile phone. The inductor should have low core loss at 1.1MHz and low DCR for better efficiency. To avoid inductor saturation current rating should be considered.

Dimming Control

a. Using a PWM Signal to EN Pin

For controlling the LED brightness, the EUP2571 can perform the dimming control by applying a PWM signal to EN pin. The average LED current is proportional to the PWM signal duty cycle. The magnitude of the PWM signal should be higher than the maximum enable voltage of EN pin, in order to let the dimming control perform correctly.

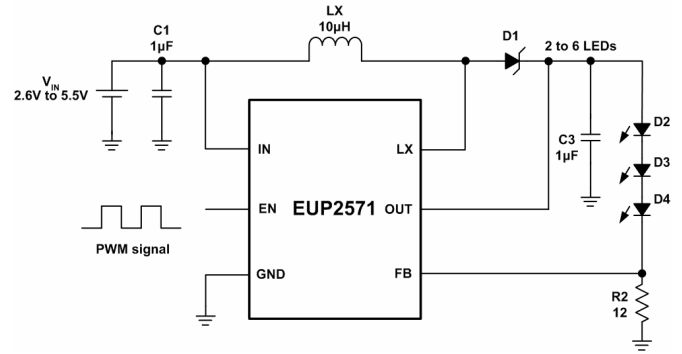

Figure 4. PWM Dimming Control Using the EN Pin

b. Using a DC Voltage

Using a variable DC voltage to adjust the brightness is a popular method in some applications. The dimming control using a DC voltage circuit is shown in Figure 5. According to the Superposition Theorem, as the DC voltage increases, the voltage contributed to V_{FB} increases and the voltage drop on R2 decreases, i.e. the LED current decreases. For example, if the V_{DC} range is from 0V to 2.8V, the selection of resistors in Figure 5 sets dimming control of LED current from 20mA to 0mA.

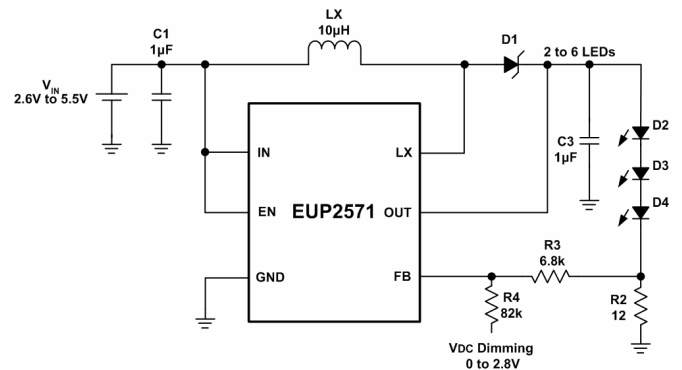

Figure 5. Dimming Control Using a DC Voltage

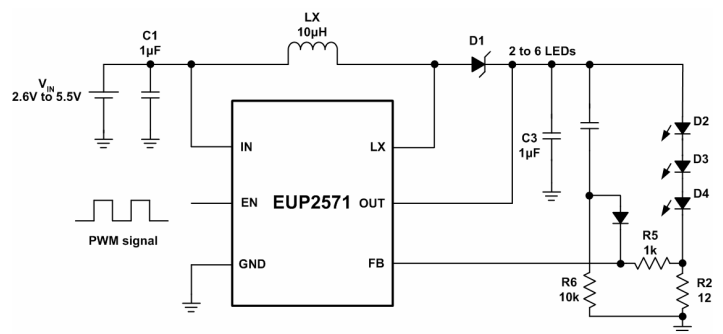

Figure 6. Recommended Soft-Start Circuit

Constant Output Voltage for Backlight of Main Panel and Keypad

Figure 9 is another application of EUP2571 for backlight and keypad. Setting the divider-resistors (R1 & R2) is to get a constant output voltage that depends on the forward voltage and the numbers of series-LEDs. It can turn on backlight of main panel and keypad at the same time. Applying different duty cycle of PWM signal above 22kHz to the backlight's switch can also control the brightness of main panel's backlight. The keypad's backlight will keep the same brightness during the dimming control of main panel. Otherwise the brightness of keypad's s backlight can also change during the dimming control of main panel by using the application circuit as figure 5. The following formula (5)(6) can determine the resistors of Figure 9.

$$R3 = \frac{V_{OUT} - 3V_{Fb} - V_{DS}}{I_b} \text{-----(5)}$$

$$R4 = R5 = R6 = \frac{V_{OUT} - 3V_{Fk}}{I_k} \text{-----(6)}$$

$$V_{DS} = I_b \times R_{DS(ON)} \text{-----(7)}$$

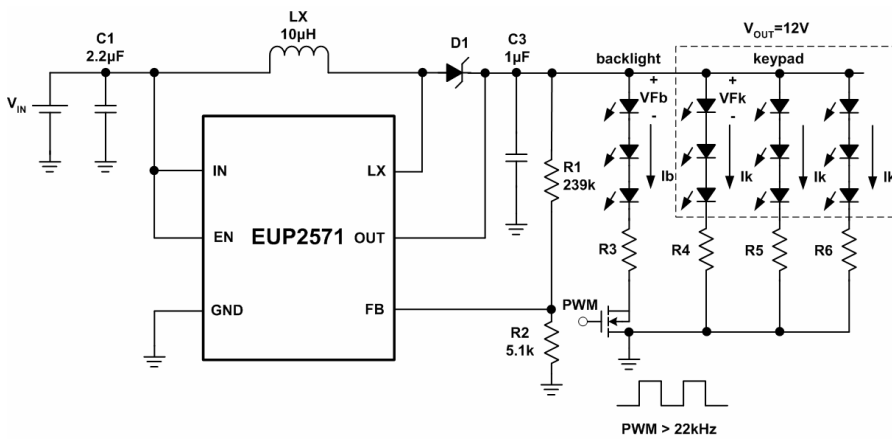
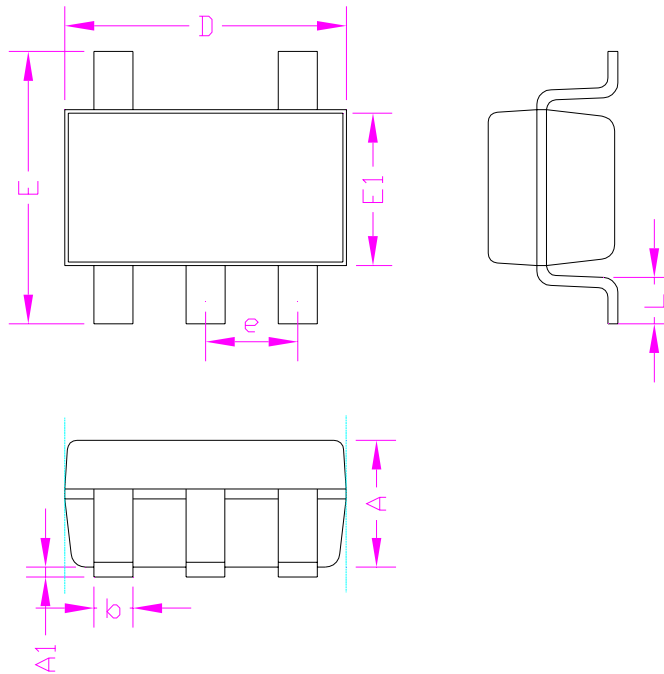

Figure 9. Constant Output Voltage for Backlight and Keypad

Packaging Information

SOT23-5



SYMBOLS	MILLIMETERS		INCHES	
	MIN.	MAX.	MIN.	MAX.
A	-	1.30	-	0.052
A1	0.00	0.15	0.000	0.006
D	2.90		0.114	
E1	1.60		0.063	
E	2.60	3.00	0.102	0.118
L	0.30	0.60	0.012	0.024
b	0.30	0.50	0.012	0.020
e	0.95		0.037	

Packaging Information

SOT23-6

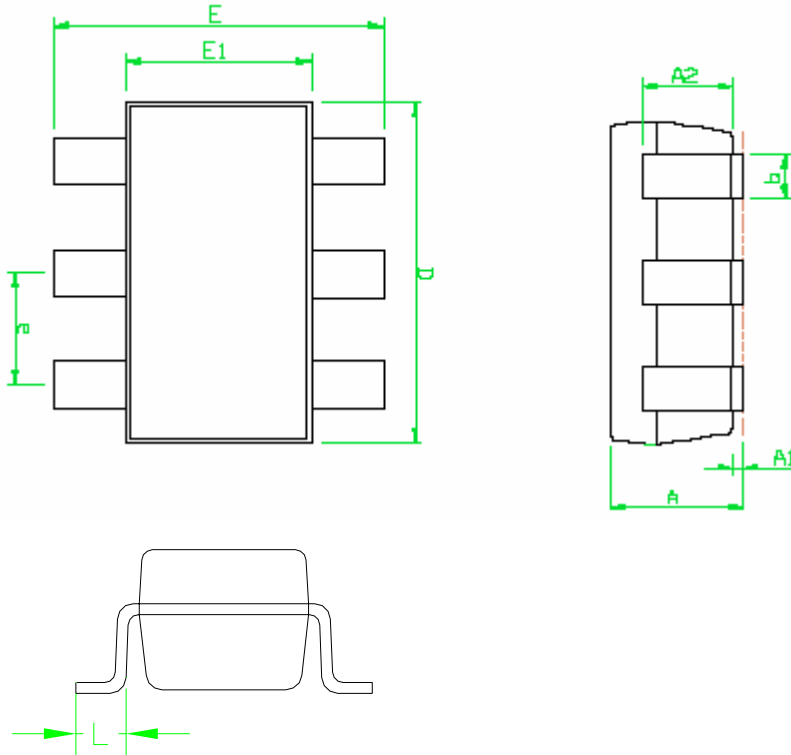

SYMBOLS	MILLIMETERS		INCHES	
	MIN.	MAX.	MIN.	MAX.
A	-	1.45	-	0.057
A1	0.00	0.15	0.000	0.006
b	0.30	0.50	0.012	0.020
D	2.90		0.114	
E1	1.60		0.063	
e	0.95		0.037	
E	2.60	3.00	0.102	0.118
L	0.3	0.60	0.012	0.024