

Flat panel sensor C7942CK-12

Acquire digital X-ray image in real time and 170 mm diagonal size

Flat panel sensors C7942CK-12 is a digital X-ray image sensor newly developed as a key device for biochemical imaging, X-ray microscopy and other real-time X-ray imaging applications requiring high resolution and high image quality.

Features

- High quality image: 2400 x 2400 pixels
- Digital output (12-bit)
- High-speed imaging:
 - 2 frames/s (single operation)
 - 9 frames/s (4 x 4 binning)
- Low noise and wide dynamic range
- Compact package
- Easy use
- CE marking
- Carbon fiber window

Applications

- Biochemical imaging
- X-ray microscopy
- Digital X-ray photography

Block diagram

C7942CK-12 is a lightweight and compact flat panel sensor consisting of a sensor board and a control board. The sensor board also has 8 charge-sensitive amplifier arrays each having 300 ch amplifiers with a horizontal shift register. Analog video signals are amplified as the charge on each video line by 2400 ch charge amplifiers with CDS (Correlated Double Sampling) circuits added, and are output each of 8 amplifier arrays. The control board converts the analog video signal into a 12-bit digital signal and outputs it to an external frame grabber through the 12-bit parallel port.

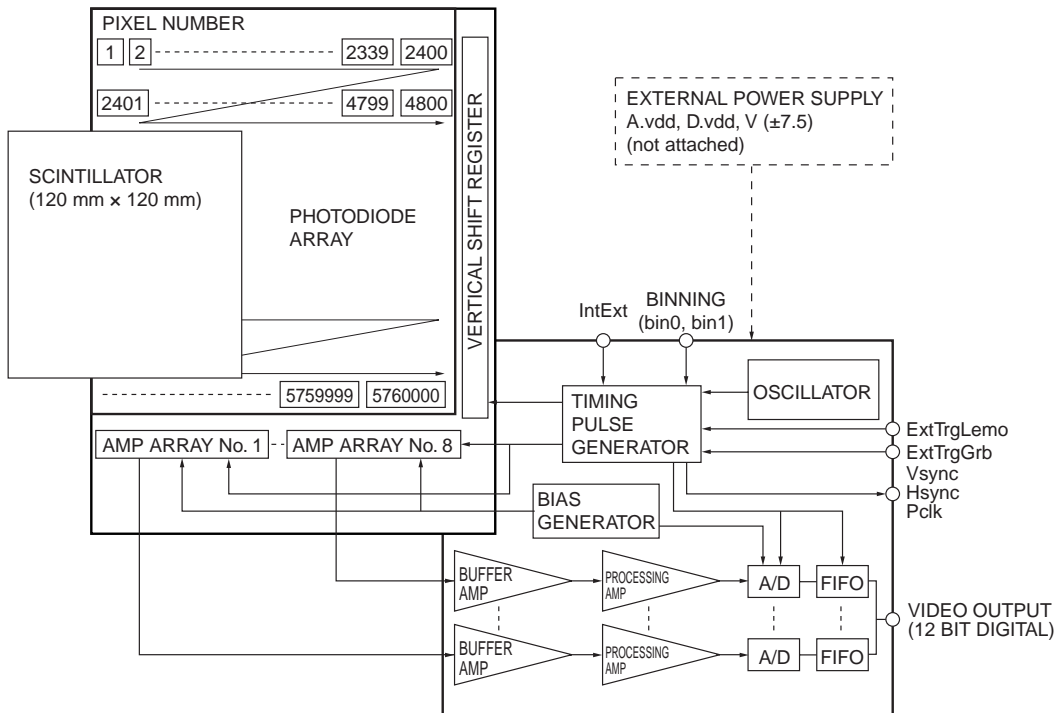

Note: Signals are read out in order of pixel number.

KACCC0216EB

General ratings

Parameter	Specification	Unit
Pixel size	50 × 50	μm
Photodiode area	120 × 120	mm
Number of pixels	2400 × 2400	M pixels
Number of active pixels	2240 × 2344	pixels
Readout	Charge amplifier array	-
Video output (Data1 - 12)	RS-422 (differential), 12-bit	-
Output data rate	15.15	MHz
Synchronous signal (Vsync, Hsync, Pclk)	RS-422 (differential)	-
bin0/1, ExtTrgGrb, ExtTrgLemo, IntExt	TTL	-
Scintillator	Csl	-

Absolute maximum ratings (Ta=25 °C)

Parameter	Symbol	Value	Unit
Supply voltage for digital circuitry (+5 V)	D.vdd	+6.0	V
Supply voltage for analog circuitry (+5 V)	A.vdd	+6.0	V
Supply voltage for analog circuitry (±7.5 V)	V(±7.5)	±12	V
Input voltage (bin0/1, ExtTrgGrb, ExtTrgLemo, IntExt)	Vin	0 to 6.0	V
Operating temperature *1	Topr	0 to +35	°C
Storage temperature *1	Tstg	0 to +50	°C

*1: No condensation

Specification (Ta=25 °C A.vdd= 5.0 V, D.vdd= 5.0 V, V (±7.5)= ±7.5 V)

Parameter	Symbol	Min.	Typ.	Max.	Unit
Frame rate (single operation)	Sf (int)	1.9	2	-	frames/s
Frame rate (2 × 2 binning)	-	-	4	-	frames/s
Frame rate (4 × 4 binning)	-	-	9	-	frames/s
Frame rate external (single operation)	Sf (ext)	-	Sf (int) to 0.1	-	frames/s
Noise (rms) *2	N (rms)	-	1100	-	electrons
Sensitivity *3	S	28	35	-	LSB/mR
Saturation charge	Csat	-	2.2	-	M electrons
Resolution *4	Reso	6	8	-	line pairs/mm
Dynamic range	-	-	2000	-	-
Defect line *5	-	-	-	20	lines
Output offset *6	-	-	65	200	-

*2: Internal trigger mode, single operation

*3: At 80 kVp without filter

*4: Spatial frequency at CTF=5 %

*5: A defect line is a horizontal or vertical line containing 4 or more pixels that produce less than 1/8 of the average output from surrounding pixels and are formed continuously from the opposite side of an amplifier array or a vertical shift register. Without a couple of adjacent defect line.

*6: Average of all effective pixels in single operation at Sf (int)

Note: X-ray energy range is 20 k to 80 kVp.

Resolution

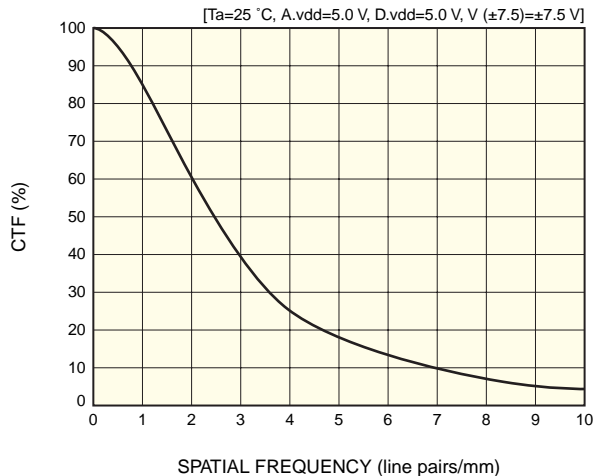

■ Timing chart

To acquire images through an image grabber board, write parameters in the software program or parameter file by referring to the following timing chart and description.

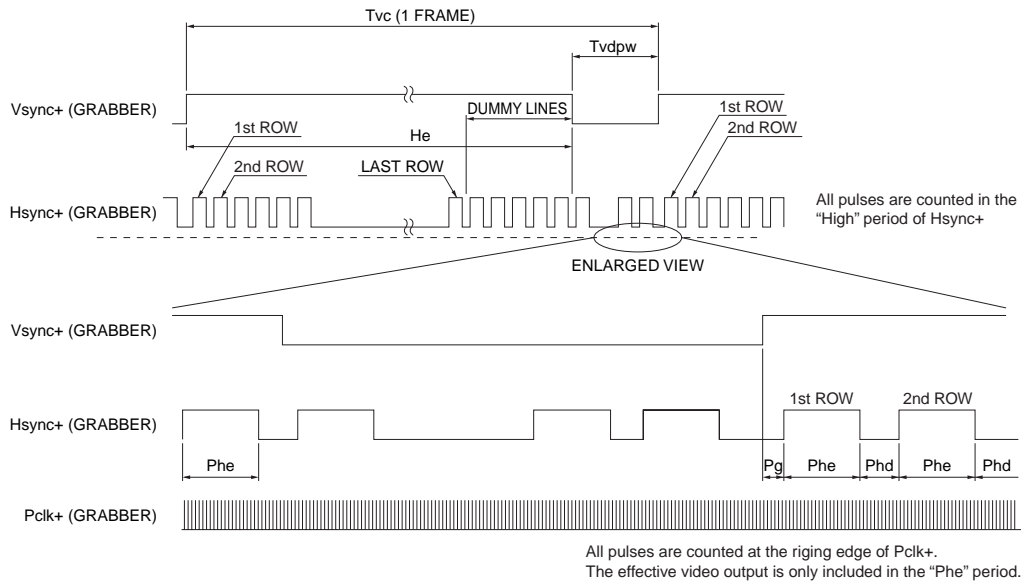

KACCC0362EB

Parameter		Pulse		
		1 × 1	2 × 2	4 × 4
He	Effective line	2344	1172	586
	Dummy line	56	28	14
Phe	Effective pixel	2240	1120	560
	Dummy pixel	160	80	40
Phd		526	1726	2326
Pg		21	21	21

Note: "He" is the Hsync count. Phe, Phd and Pg are the Pclk count.

■ External trigger mode

To acquire images in external trigger mode, input an external trigger pulse as shown below. When the time Tvd has passed after the rising edge of the external trigger pulse, synchronous signals and video signals are output.

When used in synchronization with a pulsed X-ray source, X-rays should be irradiated during the Txray period.

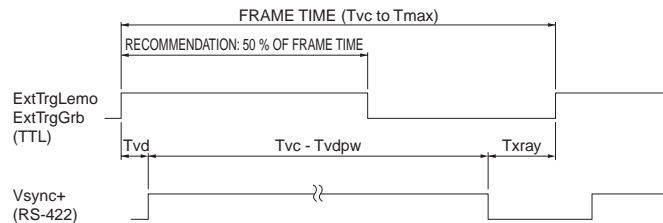

Hsync+, Pclk+ and Data 1-12 are the same as internal trigger mode.
 · Tmax is defined as the reciprocal of the minimum value of Sf (ext).
 · Txray = FRAME TIME - Tvd - (Tvc - Tvdpw)

KACCC0363EB

(Typ.)

Parameter		Symbol	1 × 1 mode	2 × 2 mode	4 × 4 mode	Unit
Vsync	Delay time (only external trigger mode)	Tvd	390	390	390	μs
	Cycle time (internal trigger mode)	Tvc	470	230	117	ms
	Dummy pulse width	Tvdpw	770	770	770	μs

Note: The numbers of significant figures is two. (except Tvc)

■ System requirements

To operate C7942CK-12 at full performance, the following system and peripherals are required.

- PC: IBM compatible PC running on Windows XP
- Digital frame grabber card: Monochrome 16 bits or more, pixel clock 16 MHz or more, RS-422 interface synchronous signal (See the frame grabber manual.)

The National Instruments IMAQ PCI-1424 (NI parts No. 777662-01) frame grabber with optional memory 64 MB (NI parts No. 920130-64) has been verified to successfully acquire 12-bit digital images from C7942CK-12. You can utilize the demonstration software that comes with the frame grabber as a simple viewer, to acquire and save an image. To do so, refer to the frame grabber user's guide for how to use the camera information file for the demonstration software.

- Power source: A.vdd = +5.0 ± 0.1 V (700 mA), D.vdd = +5.0 ± 0.1 V (1000 mA), V (±7.5) = ±7.5 ± 0.5 V (±100 mA)

Please use a series power supply. (Avoid using a switching power supply.) A power cable (terminated with an FGG.2B.307.CLAD92Z plug at one end and open at the other end; 2 m; see Table 2.), an external trigger cable (terminated with an FFA.0S.302.CLAC37 plug at one end and open at the other end; 5 m; see table 3.) and an earth cable (AWG 18; 4 m) comes supplied with C7942CK-12. An optional frame grabber cable for interface with the 36-pin receptacle (see Table 1) on C7942CK-12 is also available for synchronous signal, video output and external control.

The voltages described above are specified at the flat panel sensor side. The impedance of the power cable attached with the flat panel sensor is low enough but it causes 0.1 V approx. drop. Therefore the voltage at the power source side should be set 0.1 V higher than the voltage specified above.

Install a noise filter on the AC power input line to prevent surges on the AC line.

To supply the synchronous signal through ExtTrgGrb, apply high level of TTL to ExtTrgLemo and IntExt, or leave them without connection. On the contrary, to use ExtTrgLemo, set high level to ExtTrgGrb and IntExt, or leave them without connection. The earth terminal must be connected to a stable earth point to eliminate noise from surroundings.

Table 1: Pin assignment of 36-pin receptacle

Pin No.	Signal	Pin No.	Signal
1	Data12+ (MSB)	19	Data12- (MSB)
2	Data11+	20	Data11-
3	Data10+	21	Data10-
4	Data9+	22	Data9-
5	Data8+	23	Data8-
6	Data7+	24	Data7-
7	Data6+	25	Data6-
8	Data5+	26	Data5-
9	Data4+	27	Data4-
10	Data3+	28	Data3-
11	Data2+	29	Data2-
12	Data1+ (LSB)	30	Data1- (LSB)
13	bin0 (TTL)	31	GND
14	bin1 (TTL)	32	GND
15	ExtTrgGrb (TTL)	33	IntExt (TTL)
16	Vsync+	34	Vsync-
17	Hsync+	35	Hsync-
18	Pclk+	36	Pclk-

Unless otherwise noted, signal level is RS-422.

36-pin receptacle: TX20A-36R-D2GF1-A1L made by JAE (Japan Aviation Electronics Industry limited)

Mating plug: TX20A-36PH1-D2P1-D1E made by JAE (Japan Aviation Electronics Industry limited)

Table 2: Power pin assignment and cable color

Pin No.	Color	Signal
1	Brown	+7.5 V
2	Red	Analog GND
3	Orange	-7.5 V
4	Yellow	Analog GND
5	Green	Analog +5 V
6	Blue	Digital GND
7	Purple	Digital +5 V
Shield	-	Analog GND

7-pin power receptacle: ECG.2B.307.CLV made by LEMO S. A.

Mating power plug: FGG.2B.307.CLAD92Z made by LEMO S. A.

Table 3: External trigger pin assignment and cable color

Pin No.	Color	Signal
1	Red	ExtTrgLemo (TTL)
2	Black	Signal GND
Shield	-	Analog GND

2-pin receptacle: ECP.0S.302.DLL made by LEMO S. A.

Mating plug: FFA.0S.302.CLAC37 made by LEMO S. A.

■ Connection

Install the frame grabber board into the PC by following the manufacturer's instructions. When a general-purpose frame grabber board is used, binning or trigger operation for bin0, bin1, IntExt and ExtTrgGrb can be controlled with its digital I/O control.

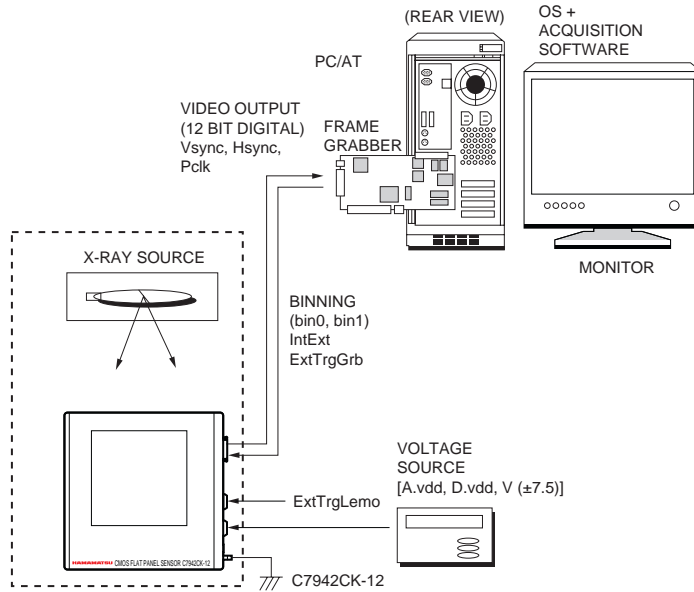

KACCC0274EB

■ Dimensional outline (unit: mm, tolerance: ± 1 mm unless otherwise noted)

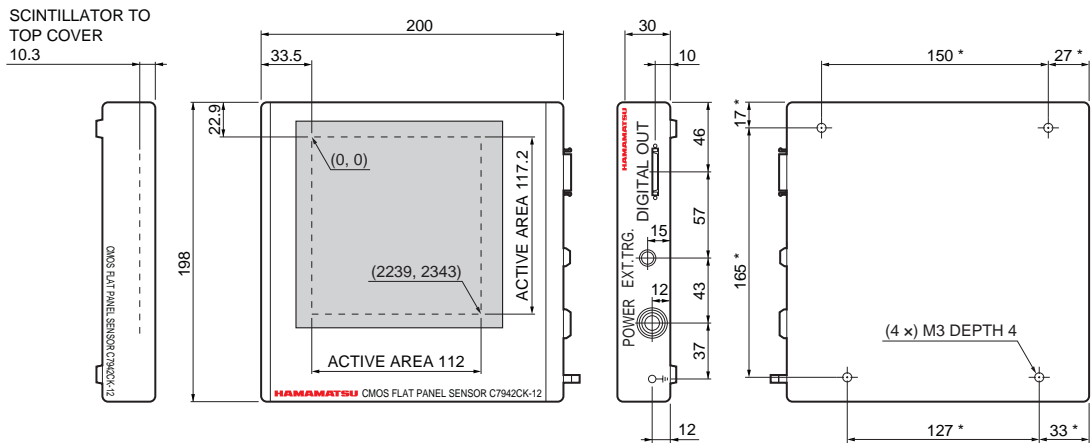

Top cover is made of carbon fiber (1.0 mm thickness).

Weight: 2.6 kg

* ± 0.5

KACCA0162ED

■ Notice

- Do not subject the Flat Panel Sensors to strong vibration or shock. (Strong shock such as drop impacts may cause permanent damage to these sensors.)
- Users must take responsibility for implementing X-ray shielding safety measures to avoid the risk of X-ray exposure.
- Data listed in this datasheet is defined at the time of shipment. Characteristics may vary somewhat due to exposure to X-rays so take proper countermeasures such as making periodic image correction.
- This product is warranted for a period of 12 months after the date of the shipment.
The warranty is limited to make a replacement or repair of any defective product due to defects in workmanship or materials used in manufacture. It does not cover loss or damage caused by natural disaster, misuse (including modifications and any use not complying with the environment, application, usage and storage conditions described in this datasheet), or total radiation dose over 500 k Roentgen (less than 80 kVp) even within the warranty period.
- As described above, flat panel sensors have limited resistance to radiation. This must be taken into account when using a flat panel sensor under continuous irradiation (in-line non-destructive inspection, etc.)
When using flat panel sensors in non-destructive inspection equipment, please contact us and provide information such as irradiation conditions.



C7942CK-12 conforms to European EMC directives:
EN61326 Class A.

■ Optional frame grabber cables

Frame grabber	Cable type No.	Cable length	Cable end	Cable end
General-purpose	A8406-31	5 m	TX20A-36PH1-D2P1-D1E *8	open
	A8406-36	7 m		
	A8406-37	10 m		
	A8406-38	12 m		
IMAQ PCI-1424 *7	A8406-32	5 m		PCS-XE100MA+ *9
	A8406-33	7 m		
	A8406-34	10 m		
	A8406-35	12 m		

*7: Made by NI (National Instruments Corporation)

*8: Made by JAE (Japan Aviation Electronics Industry, Limited)

*9: Made by Honda Tsushin Kogyo Co. Ltd.

Note: The detailed information for these optional cables is shown in the datasheet of A8406 series.