

CCD multichannel detector head C7020, C7021, C7025



Designed for front-illuminated CCD area image sensors

C7020, C7021 and C7025 are high sensitivity multichannel detector heads for use with front-illuminated FFT-CCD area image sensors. C7020 is designed for the non-cooled front-illuminated CCD image sensors (S7010 series), while C7021 and C7025 for the TE-cooled CCD image sensors (S7011/S7015 series) for detection at even lower light levels. C7020, C7021 and C7025 incorporate a low-noise driver/amplifier circuit that provide reliable operation from simple external signals. C7021 and C7025 also include a highly stable temperature controller that cools the sensor to a preset temperature level ($T_s = -10\text{ }^\circ\text{C}$) as soon as the power is turned on. If the cooler fails and causes internal circuitry to overheat, the built-in protection circuit automatically turns off the power to the thermoelectric cooler. Despite its compact size, the housing configuration is designed for good heat dissipation, and threaded mounting holes on the front panel allow connections to other devices such as monochrometers. The table below shows front-illuminated CCD image sensors for C7020, C7021 and C7025. C7020, C7021 and C7025 do not come with a CCD image sensor, so select the desired sensor and order it separately. Controller for multichannel detector head C7557 is also available. The software supplied with the C7557 allows easy control of the multichannel detector head and data acquisition.

Features

- Designed for front-illuminated CCD area image sensor *1
C7020: for non-cooled type
C7021, C7025: for TE-cooled types
- Line binning operation *2/area scanning operation
- Driver/amplifier circuit for low noise CCD operation
- Highly stable temperature controller (C7021, C7025)
Cooling temperature: fixed at $-10 \pm 0.05\text{ }^\circ\text{C}$
- Simple signal input operation
- Compact configuration

Applications

- Fluorescence spectroscopy
- Raman spectroscopy
- Other low light level detection

■ Selection guide

The table below shows CCD area image sensors applicable for C7020, C7021, C7025. Since C7020, C7021, C7025 do not include a CCD area image sensor, so select the desired sensor and order it separately.

Type No.	CCD area image sensor			
	Type No.	Number of pixels	Number of active pixels	Active area [mm (H) × mm (V)]
C7020	S7010-0906	532 × 64	512 × 60	12.288 × 1.440
	S7010-0907	532 × 128	512 × 124	12.288 × 2.976
	S7010-0908	532 × 256	512 × 252	12.288 × 6.048
	S7010-1006	1044 × 64	1024 × 60	24.576 × 1.440
	S7010-1007	1044 × 128	1024 × 124	24.576 × 2.976
	S7010-1008	1044 × 256	1024 × 252	24.576 × 6.048
C7021	S7011-0906	532 × 64	512 × 60	12.288 × 1.440
	S7011-0907	532 × 128	512 × 124	12.288 × 2.976
	S7011-1006	1044 × 64	1024 × 60	24.576 × 1.440
	S7011-1007	1044 × 128	1024 × 124	24.576 × 2.976
C7025	S7015-0908	532 × 256	512 × 252	12.288 × 6.048
	S7015-1008	1044 × 256	1024 × 252	24.576 × 6.048

*1: The FFT-CCD (full frame transfer CCD) has charge transfer sections that are also used as light receiving areas, being different from interline transfer CCD (IT-CCD) commonly used in video cameras. Compared to the IT-CCD, the FFT-CCD offers advantages of low dark current, a 100 % open area ratio and low image lag.

*2: The FFT-CCD was originally designed as a two-dimensional image sensor. However, it can be operated like a linear image sensor having a large active area by transferring all the pixel signals in the vertical direction to the horizontal register (this is referred to as line binning).

■ Absolute maximum ratings

Parameter		Symbol	Min.	Typ.	Max.	Unit
Supply voltage (for digital circuitry)		VD1	-0.5	-	+7	V
Supply voltage (for analog circuitry)		VA1+	-	-	+18	
		VA1-	-	-	-18	
		VA2	-	-	+30	
Supply voltage *3		VD2	-	-	+7	
		Vp	-	-	+7	
		VF	-	-	+14	
Digital input voltage		-	-	-	VD (1, 2)	
Operating temperature	C7020	Topr	0	-	+50	°C
	C7021, C7025		+10	-	+35 *3	
Storage temperature	C7020	Tstg	-20	-	+70	
	C7021, C7025		0	-	+50	

■ Electrical characteristics

(Ta=25 °C, VD1=+5 V, VA1+=+15 V, VA1=- -15 V, VA2=+24 V, VD2=+5 V, Vp=+5 V, VF=+12 V, unless otherwise noted)

Parameter		Symbol	Min.	Typ.	Max.	Unit
Digital input	High level	V _{IH}	+2.0	-	VD (1, 2)	V
	Low level	V _{IL}	-0.5	-	+0.8	V
CLK frequency		f _{clk}	-	-	1	MHz
Data video readout frequency		f _v	-	-	f _{CLK} /4	Hz
Start pulse width		t _{st}	1/f _{CLK}	-	-	s
Digital output	High level (I _o = -6 mA)	V _{IH}	+2.0	-	-	V
	Low level (I _o =+6 mA)	V _{IL}	-	-	+0.8	V
Power supply operating conditions						
Voltage	Digital circuitry	VD1	+4.75	+5.0	+5.25	V
	Analog circuitry	VA1+	+14.5	+15.0	+15.5	V
		VA1-	-14.5	-15.0	-15.5	V
		VA2	+23.5	+24.0	+24.5	V
	Other	VD2	+4.75	+5.0	+5.25	V
		Vp	+4.75	+5.0	+5.25	V
VF		+11.75	+12.0	+12.75	V	
Current	VD1 (+5 VDC)	-	-	-	+200	mA
	VA1+ (+15 VDC)	-	-	-	+100	mA
	VA1- (-15 VDC)	-	-	-	-100	mA
	VA2 (+24 VDC)	-	-	-	+30	mA
	VD2 (+5 VDC) *4	-	-	-	+30	mA
	Vp (+5 DC) *4	-	-	-	+2.5	A
	VF (+12 VDC) *4	-	-	+100	-	mA

■ Electrical and optical characteristics

(Ta=25 °C, Ts= -10 °C, VD1=+5 V, VA1+=+15 V, VA1=- -15 V, VA2=+24 V, VD2=+5 V, Vp=+5 V, VF=+12 V, unless otherwise noted)

Parameter		Symbol	Min.	Typ.	Max.	Unit
Spectral response range		λ	-	400 to 1100	-	nm
Full well capacity	Vertical	Fw	-	300000	-	e ⁻
	Horizontal		-	600000	-	
Conversion gain *5		Sv	-	15	-	μV/e ⁻
Dark current *6	C7020	DS	-	1000	3000	e ⁻ /pixel/s
	C7021, C7025		-	15	45	
Readout noise		Nr	-	20	-	e ⁻ _{rms}
Dynamic range		DR	-	30000	-	-
Photo response non-uniformity *7		PRNU	-	-	±10	%

*3: The maximum value may be lower, depending on the drive frequency and the number of sensor pixels.

*4: C7021, C7025

*5: Including the circuit gain.

*6: At MPP mode. Vertical register value. The actual value equals the sum of the vertical direction because of the binning operation.

*7: Measured at 50 % of the full well capacity.

■ Specifications for temperature controller (C7021, C7025)

($T_a=25\text{ }^\circ\text{C}$, $V_{D1}=+5\text{ V}$, $V_{A1+}=+15\text{ V}$, $V_{A1-}=-15\text{ V}$, $V_{A2}=+24\text{ V}$, $V_{D2}=+5\text{ V}$, $V_p=+5\text{ V}$, $V_f=+12\text{ V}$)

Parameter *8	Symbol	Min.	Typ.	Max.	Unit
Cooling temperature	T_s	-11	-10	-9	$^\circ\text{C}$
Temperature control range	ΔT_s	-0.05	-	+0.05	$^\circ\text{C}$
Power dissipation of TE-cooler element	P_p	-	-	7	W
Cool down time to reset temperature	t_o	-	-	5	min.
Setting temperature for overheat protection	T_o	-	+45	-	$^\circ\text{C}$

*8: Other functions include error display, automatic power off, and detection of electrical opens and shorts by the thermosensor.

■ Spectral response

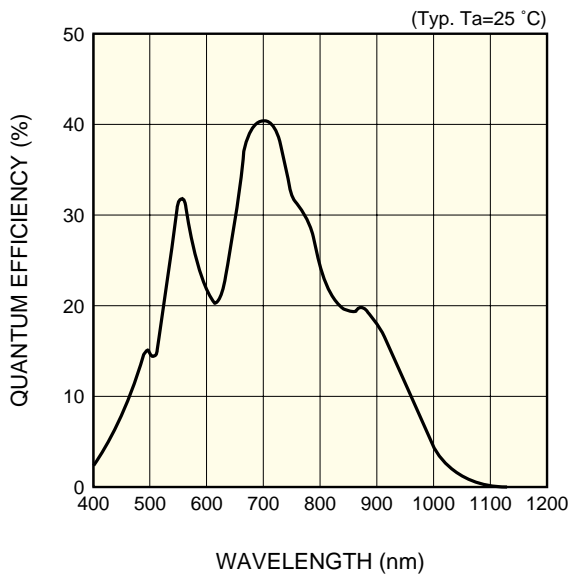

KMPDB0051EA

■ Dark current vs. temperature

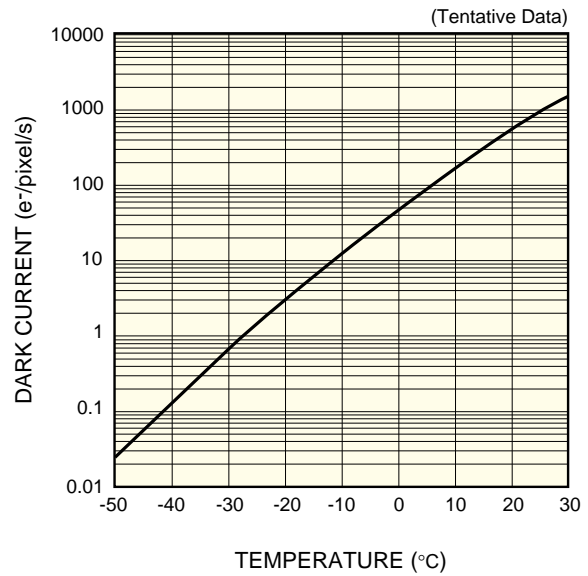

KMPDB0052EA

■ Block diagram (front-illuminated CCD area image sensor)

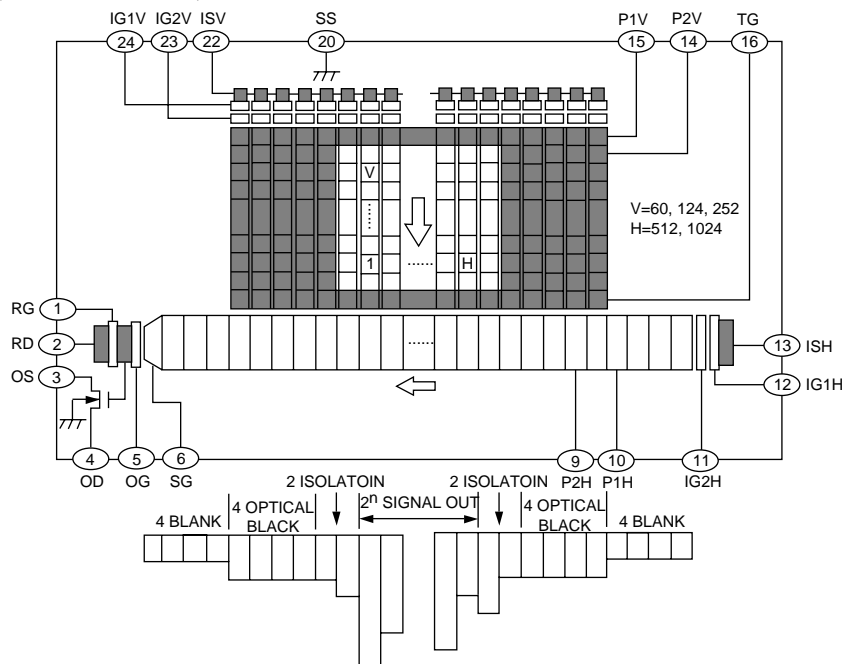

KMPDC0015EA

■ Block diagram of C7021, C7025

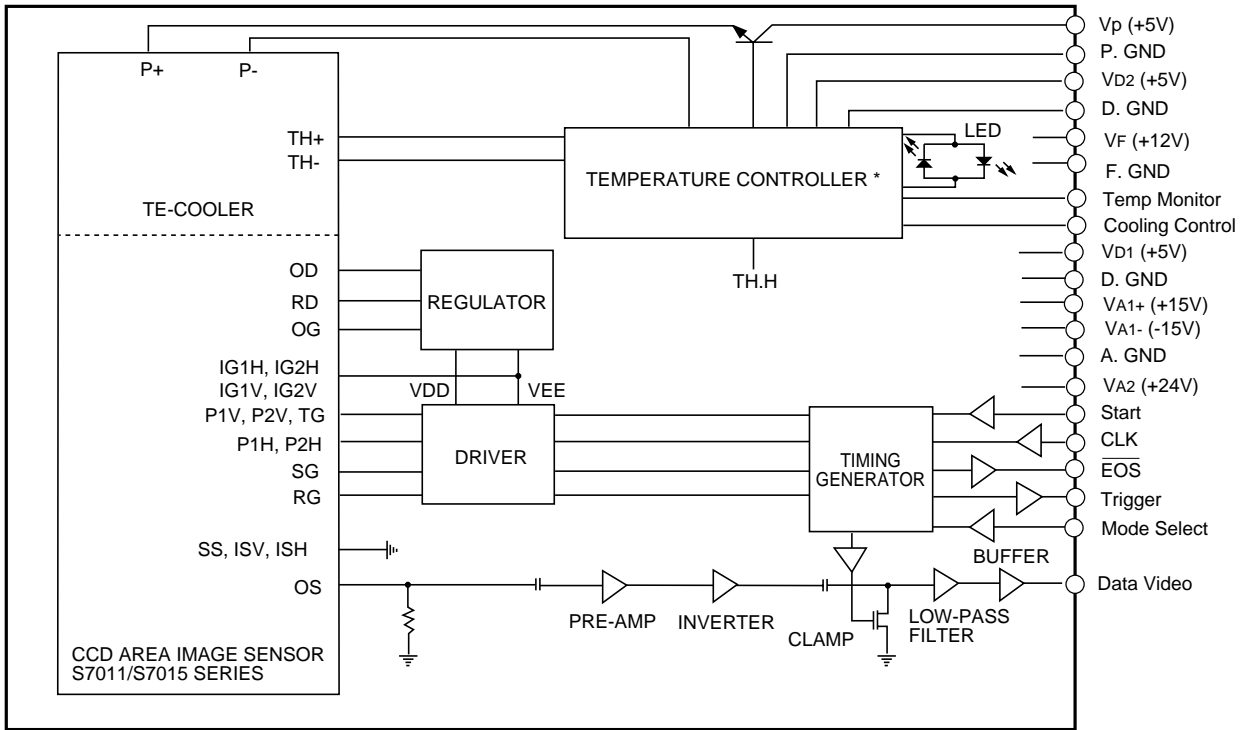

* C7020 does not include the temperature controller and TE-cooler.

KACCC0073EB

■ Timing chart

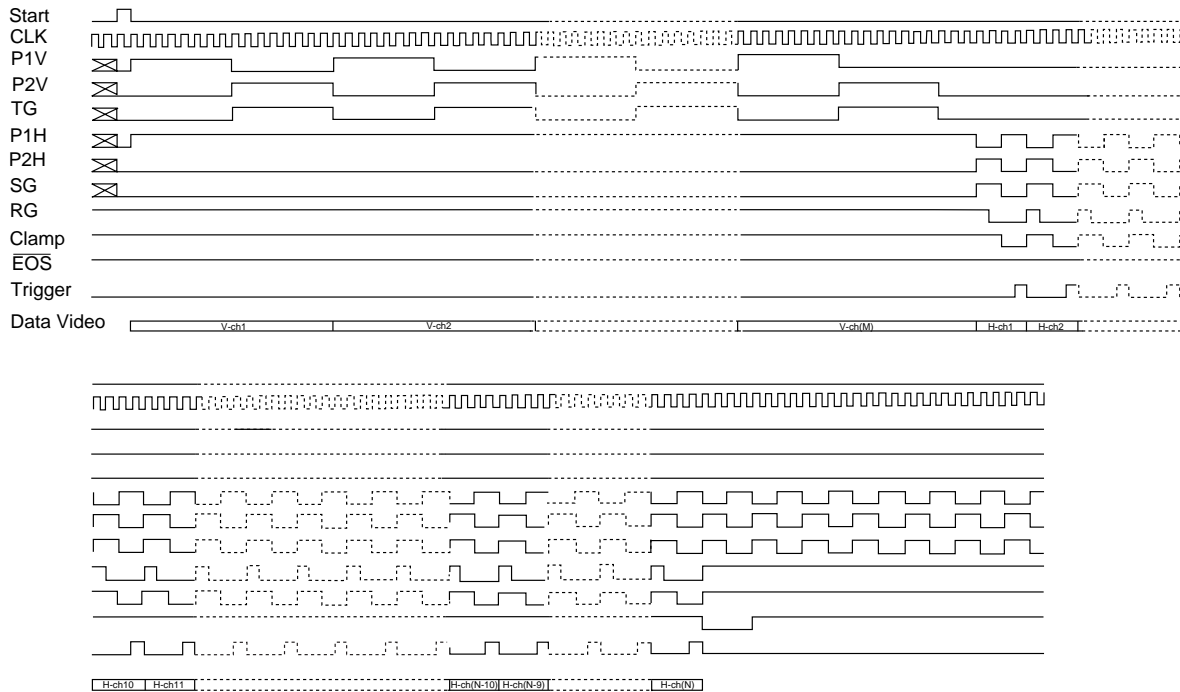

M=68, 132, 260 N=532, 1044
 V-ch1--V-ch2, V-ch (M-3)--V-ch (M): ISOLATION PIXELS
 H-ch1--H-ch4, H-ch (N-3)--H-ch (N): BLANK PIXELS
 H-ch5--H-ch10, H-ch (N-9)--H-ch (N-4): ISOLATION PIXELS

KACCC0074EB

■ Pin assignment of "SIGNAL I/O" connector

15-pin D-sub connector

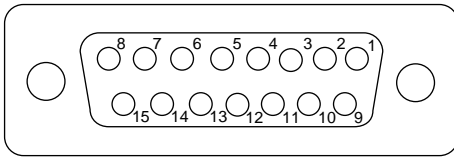

KACCC0069EA

Pin No.	Terminal name	Description
1	Mode select	Digital input signal used to select between the line binning operation and area scanning operation. HCMOS compatible. High level or left open: line binning operation Low level: area scanning operation
2	Data video	Analog video output. Positive polarity
3	VA1+ (+15 V)	Analog power supply
4	VA1- (-15 V)	Analog power supply
5	VD1 (+5 V)	Digital power supply
6	Start	Digital input signal for initializing the circuit. HCMOS compatible. Positive logic. The interval of the start pulses determines the integration time of the CCD image sensor.
7	CLK	Digital input signal for operating the circuit. HCMOS compatible. Rising edge operation.
8	$\overline{\text{EOS}}$	Digital input signal for indicating end-of-scan of the image sensor. HCMOS compatible. Negative logic.
9	A. GND	Analog ground
10	A. GND	Analog ground
11	VA2 (+24 V)	Analog power supply
12	D. GND	Digital ground
13	D. GND	Digital ground
14	D. GND	Digital ground
15	Trigger	Digital output signal for A/D conversion. HCMOS compatible. Positive logic.

■ Pin assignment of "TE CONTROL I/O" connector (C7021, C7025)

9-pin D-sub connector

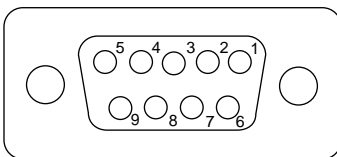

KACCC0075EA

Pin No.	Terminal name	Description
1	VD2 (+5 V)	Digital power supply
2	Temp monitor	Analog output signal of the temperature of the CCD image sensor
3	Cooling control	Digital input signal for starting to cool down. HCMOS compatible. High level or left open: cooling Low level: stand-by
4	Vp (+5 V)	Power supply for the thermoelectric cooler in the CCD image sensor. (Please use AWG 18 wire)
5	VF (+12 V)	Power supply for cooling fan
6	D. GND	Ground
7	D. GND	Ground
8	P. GND	Power supply return of the thermoelectric cooler mounted in the CCD image sensor. (Please use AWG 18 wire)
9	F. GND	Power supply return for cooling fan

Available for using same power supply (+5 V) for "+VD2" and "+Vp".

Caution: Do not connect "VD2" and "Vp" together on the backside of the 9-pin D-sub connector.

These may be connected (shorted) at the power supply end, not 9-pin D-sub connector.

■ Dimensional outlines (unit: mm)

C7020

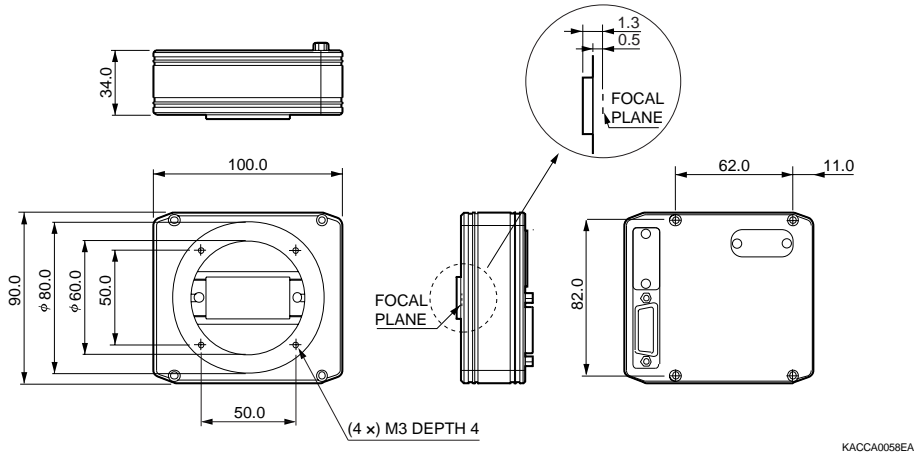

C7021

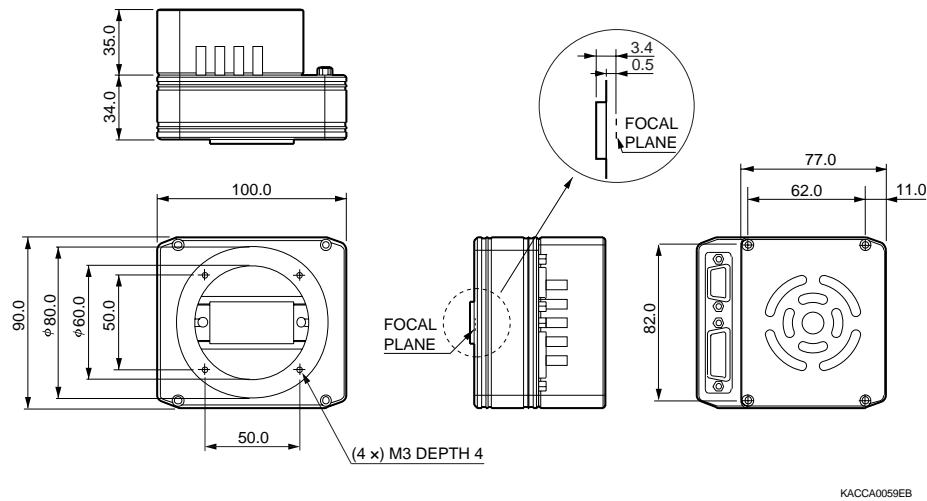

C7025

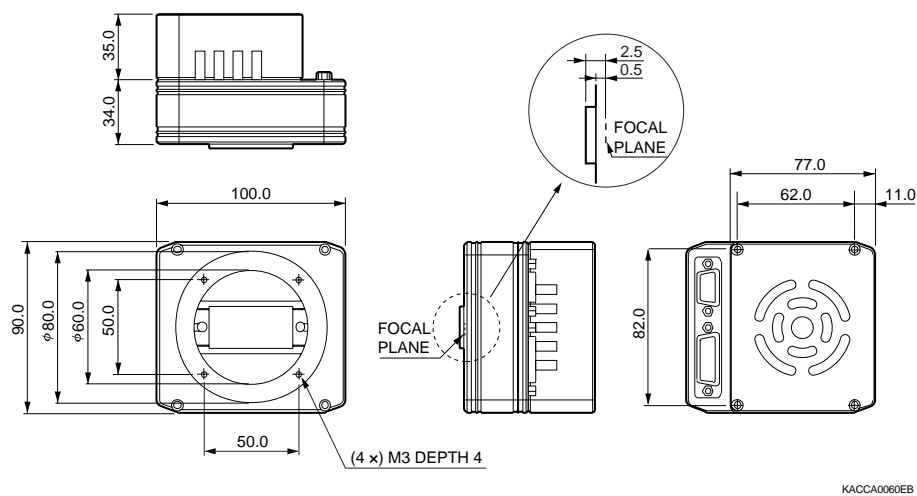

■ Connection example

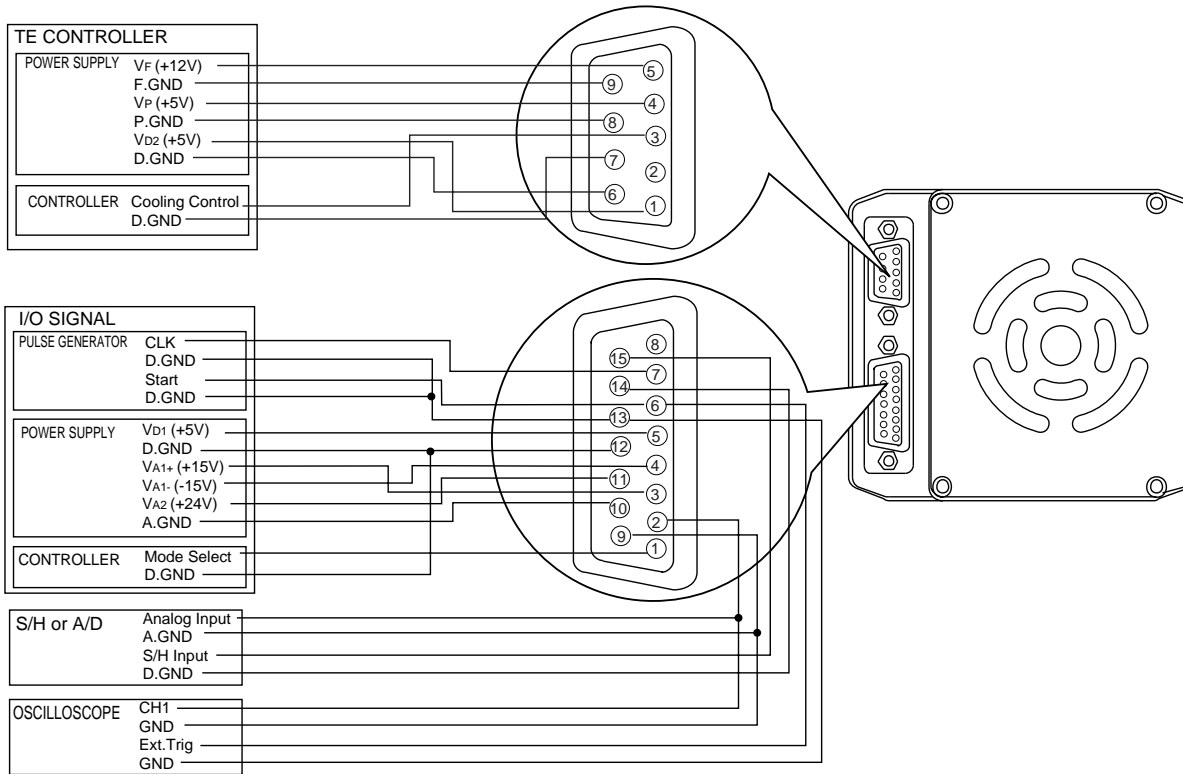

KACCC0078EC

Multichannel detector head controller C7557

When connected to a HAMAMATSU multichannel detector head and a personal computer, C7557 allows easy control of the detector head and data acquisition by using dedicated software that comes with the unit.

Suitable multichannel detector head

C7020/-02, C7021/-02, C7025/-02,
C7040, C7041, C7043, C7044, C7180,
C7181, C8061-01, C8062-01, C10150, C10151

■ Accessories

- SCSI terminator
- Fuse (2.5 A)
- Detector head connection cables
- AC cable
- Software (Compatible OS: Windows 98/ME *)
- Operation manual



* This software may be run on Windows 2000/NT/XP with a simple task. For information on how to do this, please consult with our sales office.

■ Connection

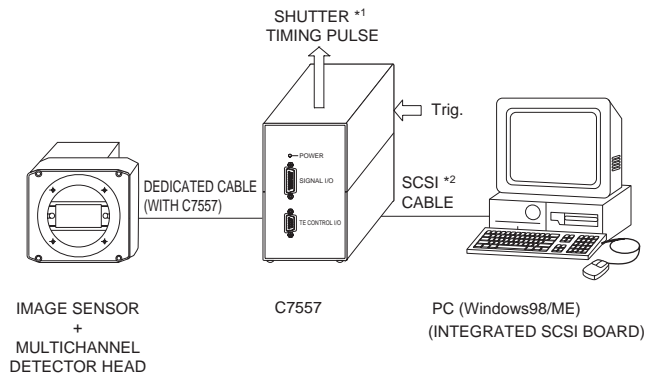

*1: Shutter, etc. are not available.

*2: SCSI cable and SCSI board (card) are not supplied with C7557.

KACCC0077ED

HAMAMATSU

Information furnished by HAMAMATSU is believed to be reliable. However, no responsibility is assumed for possible inaccuracies or omissions. Specifications are subject to change without notice. No patent rights are granted to any of the circuits described herein. ©2007 Hamamatsu Photonics K.K.

HAMAMATSU PHOTONICS K.K., Solid State Division

1126-1 Ichino-cho, Higashi-ku, Hamamatsu City, 435-8558 Japan, Telephone: (81) 53-434-3311, Fax: (81) 53-434-5184, www.hamamatsu.com

U.S.A.: Hamamatsu Corporation: 360 Foothill Road, P.O.Box 6910, Bridgewater, N.J. 08807-0910, U.S.A., Telephone: (1) 908-231-0960, Fax: (1) 908-231-1218

Germany: Hamamatsu Photonics Deutschland GmbH: Arzbergerstr. 10, D-82211 Herrsching am Ammersee, Germany, Telephone: (49) 08152-3750, Fax: (49) 08152-2658

France: Hamamatsu Photonics France S.A.R.L.: 19, Rue du Saule Trapu, Parc du Moulin de Massy, 91882 Massy Cedex, France, Telephone: 33-(1) 69 53 71 00, Fax: 33-(1) 69 53 71 10

United Kingdom: Hamamatsu Photonics UK Limited: 2 Howard Court, 10 Tewin Road, Welwyn Garden City, Hertfordshire AL7 1BW, United Kingdom, Telephone: (44) 1707-294888, Fax: (44) 1707-325777

North Europe: Hamamatsu Photonics Norden AB: Smidesvägen 12, SE-171 41 Solna, Sweden, Telephone: (46) 8-509-031-00, Fax: (46) 8-509-031-01

Italy: Hamamatsu Photonics Italia S.R.L.: Strada della Moia, 1/E, 20020 Arese, (Milano), Italy, Telephone: (39) 02-935-81-733, Fax: (39) 02-935-81-741

Cat. No. KACC1035E09
May 2007 DN