



**Size 7x7 mm**

**Rated inductance 1  $\mu$ H .. 1000  $\mu$ H**

### Construction

- Ferrite core
- Magnetically shielded
- Winding: enamel copper wire
- Winding soldered to terminals

### Features

- Wide temperature range
- High rated current
- Low DC resistance
- Suitable for reflow soldering

### Applications

- Filtering of supply voltages
- Coupling, decoupling
- DC/DC converters
- Automotive electronics

### Terminals

- Leadfree tinned

### Marking

Marking on component:  
L value (in  $\mu$ H), date code

Minimum marking on reel:  
Manufacturer, part number, ordering code,  
L value and tolerance  
quantity, date of packing

### Delivery mode

16mm–Blister tape, reel packing  
packaging quantity 1000pcs/reel



**General technical data**

Rated inductance $L_R$	Measured with HP 4284A, measuring voltage 100 mV
DC resistance $R_{max}$	Measured at 20 °C ambient temperature
Rated current $I_R$	Maximum permissible DC with temperature increase of $\leq 40$ K at ambient temperature of 85 °C
Saturation current $I_{Sat}$	Maximum permissible DC with inductance decrease $\Delta L/L_0 \approx 10\%$
Climatic category	In accordance with IEC 60068-1 55/125/56 (-55 °C/ +125 °C/ 56 days damp heat test)
Solderability	5s, 235°C, wetting > 90%
Weight	Approx. 1,5g

**Dimensional drawing and layout recommendation**

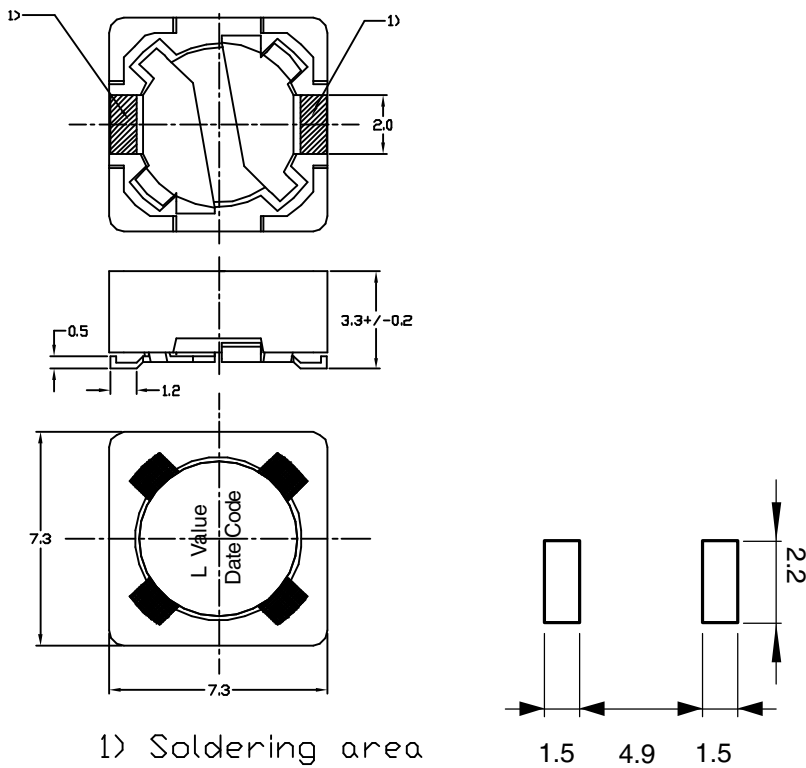



**Characteristics and ordering codes**

$L_R$ $\mu\text{H}$	$f_L$ kHz	Tolerance	$I_R$ A	$I_{\text{Sat}}$ A	$R_{\text{max}}$ $\Omega$	Ordering code
1,0	100	20 %	3,45	2,90	0,018	B82472-G4102-M
1,5	100	20 %	3,35	2,60	0,020	B82472-G4152-M
2,2	100	20 %	2,90	2,20	0,025	B82472-G4222-M
3,3	100	20 %	2,60	1,9	0,035	B82472-G4332-M
4,7	100	20 %	2,30	1,70	0,043	B82472-G4472-M
6,8	100	20 %	2,05	1,40	0,055	B82472-G4682-M
10	100	20 %	1,70	1,34	0,08	B82472-G4103-M
15	100	20 %	1,40	1,10	0,12	B82472-G4153-M
22	100	20 %	1,10	0,90	0,20	B82472-G4223-M
33	100	20 %	0,94	0,72	0,25	B82472-G4333-M
47	100	20 %	0,86	0,65	0,30	B82472-G4473-M
56	100	20 %	0,84	0,63	0,31	B82472-G4563-M
68	100	20 %	0,69	0,60	0,46	B82472-G4683-M
100	100	20 %	0,56	0,45	0,70	B82472-G4104-M
150	100	20 %	0,49	0,35	0,80	B82472-G4154-M
180	100	20 %	0,47	0,32	0,95	B82472-G4184-M
220	100	20 %	0,40	0,30	1,10	B82472-G4224-M
330	100	20 %	0,29	0,26	1,98	B82472-G4334-M
470	100	20 %	0,26	0,24	2,70	B82472-G4474-M
680	100	20 %	0,23	0,19	3,65	B82472-G4684-M
820	100	20 %	0,20	0,17	3,90	B82472-G4824-M
1000	100	20 %	0,18	0,13	4,78	B82472-G4105-M

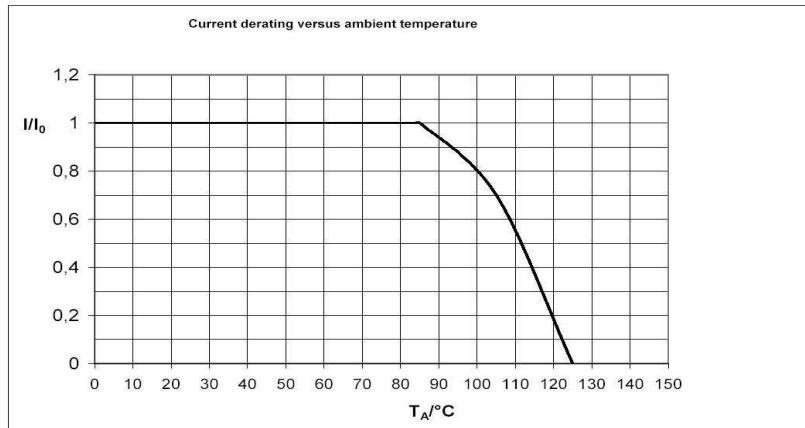

Typical diagrams:



Impedance versus frequency

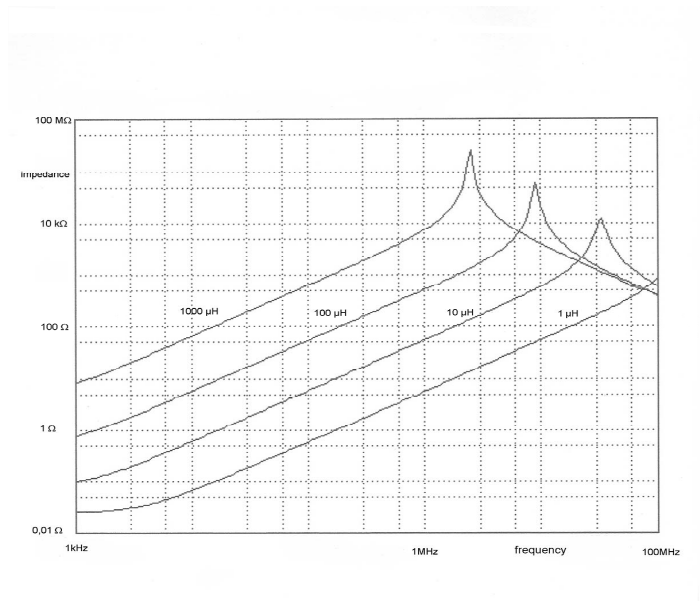

Inductance derating versus load current

