



High-Voltage, 350mA LED Driver with Analog and PWM Dimming Control

MAX16804

General Description

The MAX16804 current regulator operates from a 5.5V to 40V input voltage range and delivers 35mA to 350mA to one or more strings of high-brightness LEDs (HB LEDs). The output current of the MAX16804 is set by using an external current-sense resistor in series with the LEDs. A dual-mode DIM pin and on-board 200Hz ramp generator allow PWM dimming with an analog or PWM input signal. The analog control signal at dimming input DIM allows for a theater-dimming effect to be implemented. Fast turn-on and turn-off times ensure a wide-range PWM operation, while wave-shaping circuitry minimizes EMI. The differential current-sense input increases LED current accuracy and noise immunity. The MAX16804 is well suited for applications requiring high-voltage input and is able to withstand automotive load-dump events up to 45V. An on-board pass element minimizes external components while providing 3% output-current accuracy. Additional features include a 5V regulated output and short-circuit and thermal protection.

The MAX16804 is available in a thermally enhanced, 5mm x 5mm, 20-pin TQFN package and is specified over the automotive -40°C to +125°C temperature range.

Applications

Automotive Interior: Map, Dome, and Courtesy Lighting

Automotive Exterior:

Rear Combination Light (RCL)

Daytime Running Light (DRL)

Adaptive Front Light

Warning Lights for Emergency Vehicles

Navigation and Marine Indicators

Signage, Canopies, and Beacons

Features

- ◆ Flexible Dimming Control, Analog or PWM Control Signal for PWM and Theater Dimming
- ◆ 200Hz On-Board Ramp Generator
- ◆ Sinks to External PWM Signal (Up to 2kHz)
- ◆ 5.5V to 40V Operating Range
- ◆ 35mA to 350mA Adjustable LED Current
- ◆ 3% LED Current Accuracy
- ◆ High-Voltage (Up to 40V) DIM Pin
- ◆ Integrated Pass Element with Low-Dropout Voltage (0.5V typ)
- ◆ Additional +5V On-Board Regulator with 2mA Capability
- ◆ Differential LED Current Sense
- ◆ Low 200mV Current-Sense Reference Reduces Power Losses
- ◆ Wave-Shaped Edges Minimize EMI During PWM Dimming
- ◆ Output Short-Circuit and Thermal-Shutdown Protection
- ◆ Available in Small, Thermally Enhanced, 5mm x 5mm, 20-Pin TQFN Package
- ◆ -40°C to +125°C Operating Temperature Range

Ordering Information

PART	TEMP RANGE	PIN-PACKAGE	PKG CODE
MAX16804ATP+	-40°C to +125°C	20 TQFN-EP*	T2055M-5

+Denotes lead-free package.

*EP = Exposed pad.

Pin Configuration appears at end of data sheet.

Simplified Diagrams

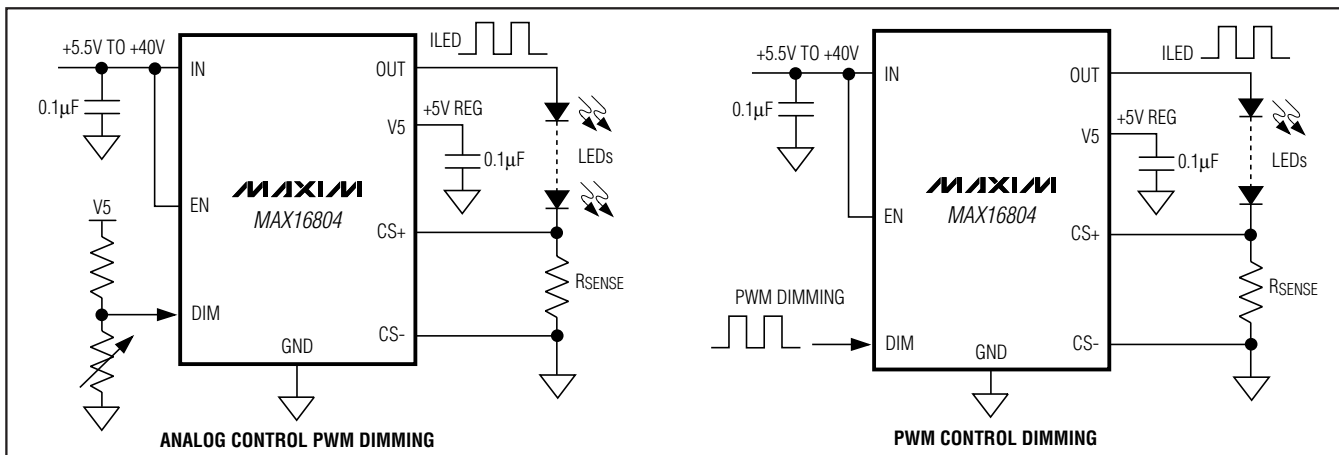

High-Voltage, 350mA LED Driver with Analog and PWM Dimming Control

ABSOLUTE MAXIMUM RATINGS

IN to GND	-0.3V to +45V
DIM, OUT, EN to GND	-0.3V to (V _{IN} + 0.3V)
IN Slew Rate (20V < V _{IN} < 45V)	250mV/μs
CS+, V5 to GND	-0.3V to +6V
CS- to GND	-0.3V to +0.3V
OUT Short Circuited to GND Duration (at V _{IN} < +16V)	1hour

Maximum Current Into Any Pin (except IN and OUT)	±20mA
Continuous Power Dissipation (T _A = +70°C)	
20-Pin TQFN (derate 34.5mW/°C above +70°C)	2758.6mW
Operating Temperature Range	-40°C to +125°C
Junction Temperature	+150°C
Storage Temperature Range	-65°C to +150°C
Lead Temperature (soldering, 10s)	+300°C

Stresses beyond those listed under "Absolute Maximum Ratings" may cause permanent damage to the device. These are stress ratings only, and functional operation of the device at these or any other conditions beyond those indicated in the operational sections of the specifications is not implied. Exposure to absolute maximum rating conditions for extended periods may affect device reliability.

ELECTRICAL CHARACTERISTICS

(V_{IN} = V_{EN} = 12V, C_{V5} = 0.1μF, I_{V5} = 0, CS- = GND, R_{SENSE} = 0.56Ω (see the *Typical Operating Circuit*), V_{DIM} = 4V, T_A = T_J = -40°C to +125°C, unless otherwise noted. Typical values are at T_A = T_J = +25°C.) (Note 1)

PARAMETER	SYMBOL	CONDITIONS	MIN	TYP	MAX	UNITS
Supply Voltage Range	V _{IN}	(Note 2)	5.5		40.0	V
Ground Current	I _G	I _{LOAD} = 350mA		2.5	4.5	mA
Shutdown Supply Current	I _{SHDN}	V _{EN} ≤ 0.3V		12	40	μA
Guaranteed Output Current	I _{OUT}	R _{SENSE} = 0.55Ω	350			mA
Output Current Accuracy		35mA < I _{OUT} < 350mA, not including R _{SENSE} tolerance			3	%
Dropout Voltage (Note 3)	ΔV _{DO}	I _{OUT} = 350mA, 12V < V _{IN} < 40V		0.4	1.2	V
		I _{OUT} = 350mA, 6.5V < V _{IN} < 12V		0.5	1.5	
Output Current Slew Rate (External PWM Signal at DIM)		Current rising, DIM rising to 4V		17		mA/μs
		Current falling, DIM falling to 0.6V		17		
Short-Circuit Current		V _{OUT} = 0V		600		mA
ENABLE INPUT						
EN Input Current	I _{EN}				100	nA
EN Input-Voltage High	V _{IH}		2.8			V
EN Input-Voltage Low	V _{IL}				0.6	V
Enable Turn-On Time	t _{ON}	EN rising edge to 90% of OUT		250		μs
CURRENT SENSE (Note 4)						
Regulated R _{SENSE} Voltage	V _{RSENSE}	V _{SENSE} = V _{CS+} - V _{CS-}	192	198	204	mV
Input Current (CS+)		V _{CS+} = 220mV			+14	μA
Input Current (CS-)		V _{CS+} = 220mV	-75			μA
INTERNAL RAMP GENERATOR						
Internal Ramp Frequency	f _{RAMP}		180	200	220	Hz
External Sync Frequency Range	f _{DIM}		80		2000	Hz
External Sync Voltage Low					0.4	V
External Sync Voltage High			2.8			V
EXTERNAL PWM DIMMING INPUT						
DIM Input Current					1	μA
Turn-On Time	t _{ON}	After DIM rising to 4V (Note 5)		28	52	μs
Turn-Off Time	t _{OFF}	After DIM falling to 0.6V (Note 5)		19	38	μs

High-Voltage, 350mA LED Driver with Analog and PWM Dimming Control

ELECTRICAL CHARACTERISTICS (continued)

($V_{IN} = V_{EN} = 12V$, $C_{V5} = 0.1\mu F$, $I_{V5} = 0$, $CS^- = GND$, $R_{SENSE} = 0.56\Omega$ (see the *Typical Operating Circuit*), $V_{DIM} = 4V$, $T_A = T_J = -40^\circ C$ to $+125^\circ C$, unless otherwise noted. Typical values are at $T_A = T_J = +25^\circ C$.) (Note 1)

PARAMETER	SYMBOL	CONDITIONS	MIN	TYP	MAX	UNITS
THERMAL PROTECTION						
Thermal-Shutdown Temperature	$T_{J(SHDN)}$			+155		$^\circ C$
Thermal-Shutdown Hysteresis				23		$^\circ C$
+5V REGULATOR						
Output Voltage Regulation	V5	$0 \leq I_{V5} \leq 2mA$	4.8	5.1	5.4	V
V5 Short-Circuit Current		$V5 = 0V$ (Note 6)		12		mA

Note 1: All devices are 100% production tested at $T_A = +25^\circ C$. Limits over the operating temperature range are guaranteed by design.

Note 2: Resistors were added from OUT to CS^+ to aid with the power dissipation during testing.

Note 3: Dropout is measured as follows:

Connect a resistor from OUT to CS^+ . Connect $R_{SENSE} = 0.56\Omega$ from CS^+ to CS^- . Set $V_{IN} = V_{OUT} + 3V$ (record V_{OUT} as V_{OUT1}). Reduce V_{IN} until $V_{OUT} = 0.97 \times V_{OUT1}$ (record as V_{IN2} and V_{OUT2}). $\Delta V_{DO} = V_{IN2} - V_{OUT2}$.

Note 4: $I_{V5} = 0mA$.

Note 5: t_{ON} time includes the delay and the rise time needed for I_{OUT} to reach 90% of its final value. t_{OFF} time is the time needed for I_{OUT} to drop below 10%. See the *Typical Operating Characteristics*. t_{ON} and t_{OFF} are tested with 13Ω from OUT to CS^+ .

Note 6: Thermal shutdown does not function if the output of the 5V reference is shorted to ground. Shorting V5 to GND disables the output.

Typical Operating Characteristics

($V_{IN} = 12V$, $V_{EN} = V_{IN}$, $C_{V5} = 0.1\mu F$, $I_{V5} = 0$, $CS^- = GND$, $R_{SENSE} = 0.56\Omega$, connect OUT to CS^+ , $V_{DIM} = 4V$, $T_A = +25^\circ C$, unless otherwise noted.)

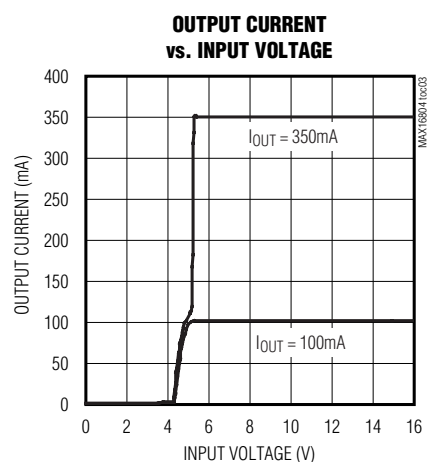
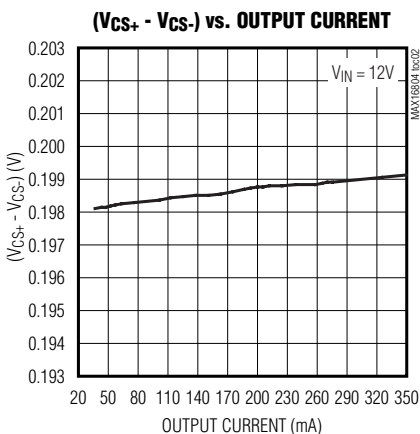
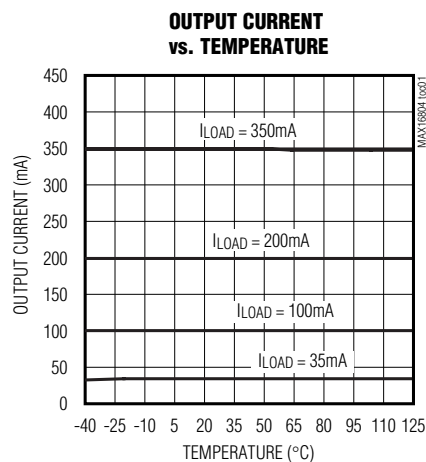

High-Voltage, 350mA LED Driver with Analog and PWM Dimming Control

Typical Operating Characteristics (continued)

($V_{IN} = 12V$, $V_{EN} = V_{IN}$, $C_{V5} = 0.1\mu F$, $I_{V5} = 0$, $CS^- = GND$, $R_{SENSE} = 0.56\Omega$, connect OUT to CS^+ , $V_{DIM} = 4V$, $T_A = +25^\circ C$, unless otherwise noted.)

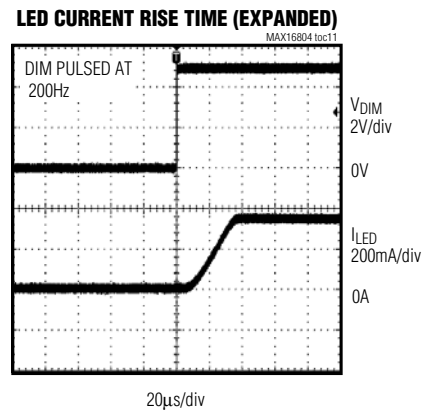
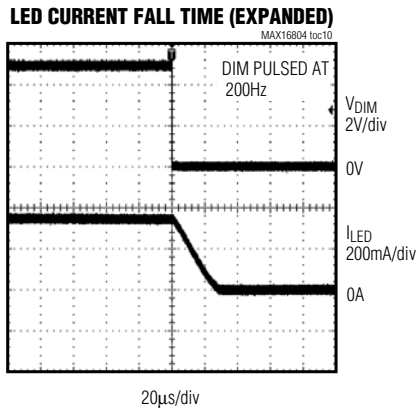
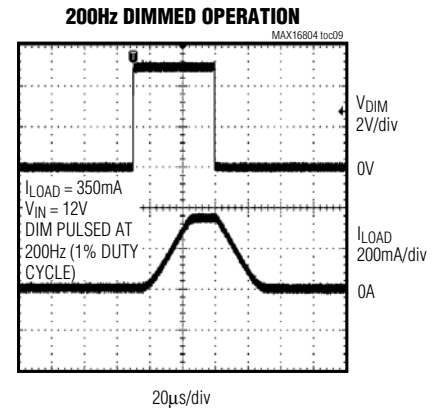
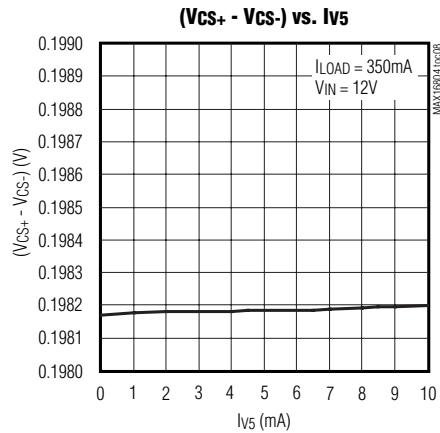
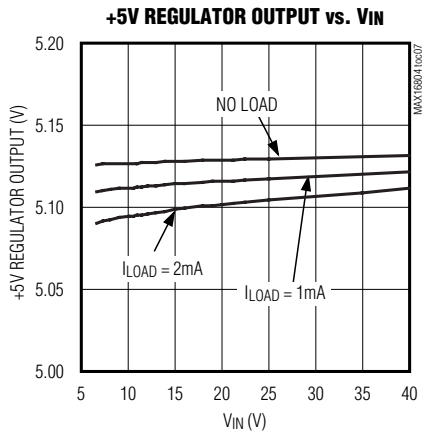
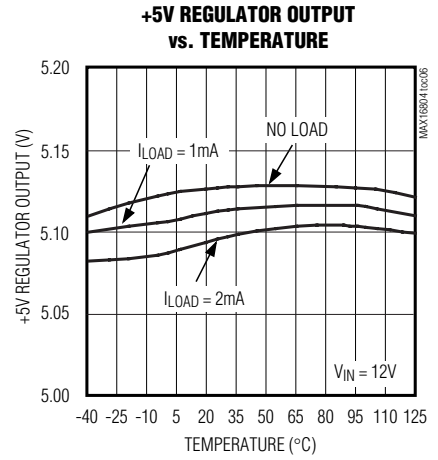
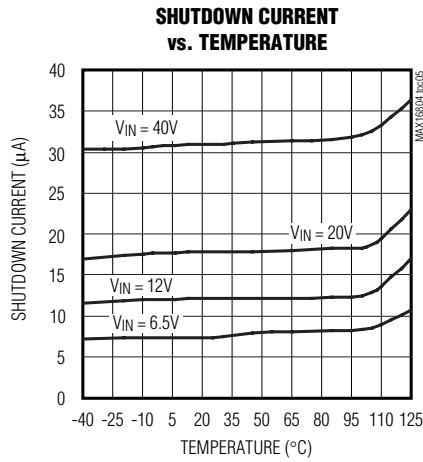
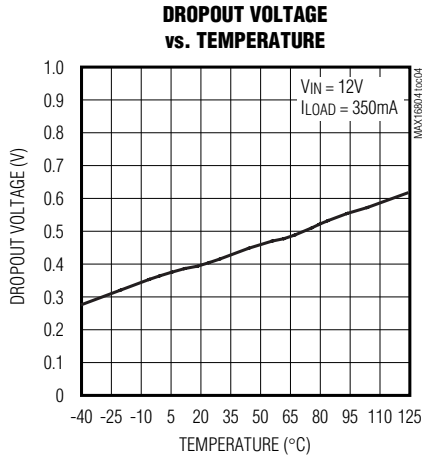

High-Voltage, 350mA LED Driver with Analog and PWM Dimming Control

MAX16804

Typical Operating Characteristics (continued)

($V_{IN} = 12V$, $V_{EN} = V_{IN}$, $C_{V5} = 0.1\mu F$, $I_{V5} = 0$, $CS^- = GND$, $R_{SENSE} = 0.56\Omega$, connect OUT to CS^+ , $V_{DIM} = 4V$, $T_A = +25^\circ C$, unless otherwise noted.)

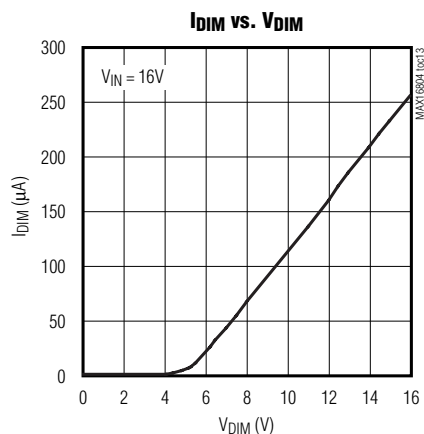
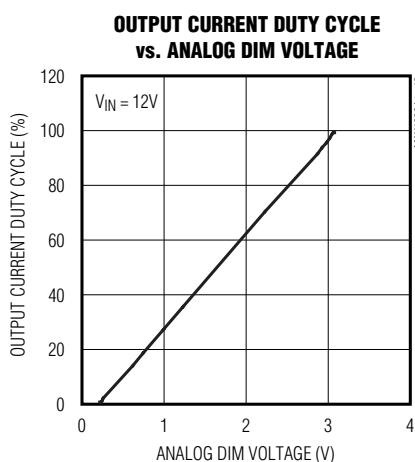

Pin Description

PIN	NAME	FUNCTION
1, 20	OUT	Current-Regulated Output. Connect pin 1 to pin 20.
2, 3	IN	Input Supply. Bypass IN with a $0.1\mu F$ (min) capacitor to GND. Connect pin 2 to pin 3.
4, 9, 11, 18	N.C.	No Connection. Leave unconnected (internal connection).
5–8, 10, 16	GND	Ground
12, 15	V5	+5V Regulated Output. Connect a $0.1\mu F$ capacitor from V5 to GND.
13	CS+	Positive Input of the Internal Differential Amplifier. Connect the current-sense resistor between CS+ and CS- to program the output current level.
14	CS-	Negative Input of the Internal Differential Amplifier. Connect the current-sense resistor between CS- and CS+ to program the output current level.
17	DIM	Dimming Input. See the <i>Dimming Input (DIM)</i> section.
19	EN	Enable Input. Drive EN high to enable the output and the 5V LDO.
—	EP	Exposed Pad. Connect to the ground plane for effective power dissipation. Do not use as the only ground connection.

High-Voltage, 350mA LED Driver with Analog and PWM Dimming Control

Functional Diagram

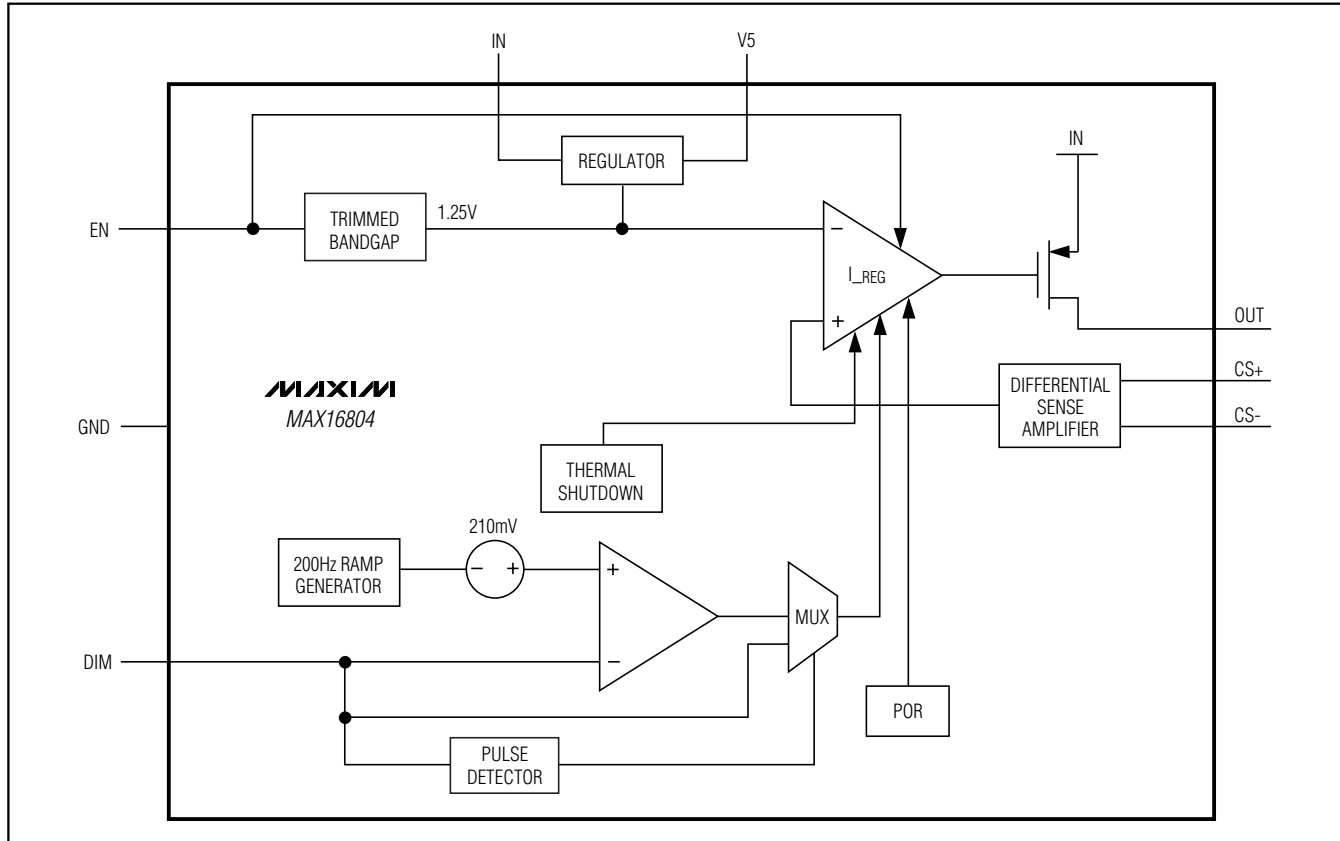

Detailed Description

The MAX16804 is a high-current regulator capable of providing up to 350mA of current to one or more strings of HB LEDs. A wide operating input voltage range of 5.5V to 40V makes the MAX16804 ideal for automotive applications. A +5V regulated output provides up to 2mA of current to power external circuitry. In addition, the MAX16804 features thermal and output short-circuit protection. The wide operating voltage range helps protect the MAX16804 against large transients such as those found in load-dump situations up to 45V.

The MAX16804 uses a feedback loop to control the output current. The differential voltage across the sense resistor is compared to a fixed reference voltage, and the error is amplified to serve as the drive to the internal pass device (see the *Functional Diagram*). The regulation point is factory-set at $(V_{CS+} - V_{CS-}) = 198 \pm 6\text{mV}$. The regulated current is user-defined by the value of R_{SENSE} .

The MAX16804 is a current controller internally optimized for driving the impedance range expected from one to ten or more HB LEDs.

Dimming Input (DIM)

The MAX16804's dimming input functions with either an analog or PWM control signal. If the pulse detector detects three edges of a PWM signal with a frequency range between 80Hz to 2kHz, the MAX16804 synchronizes to external PWM input signal and pulse-width-modulates the LED current. If an analog control signal is applied to DIM, the MAX16804 compares the DC input to an internally generated 200Hz ramp to pulse-width-modulate the LED current.

The output current duty cycle is adjustable from 0% to 100% ($0.21\text{V} < V_{DIM} < 3.1\text{V}$).

Use the following formula to calculate the output current duty cycle:

$$\text{Duty cycle} = (V_{DIM} - 0.21\text{V}) / (2.895\text{V}) \quad (1)$$

High-Voltage, 350mA LED Driver with Analog and PWM Dimming Control

The dimming feature can be used for LED brightness adjustment (see the *Simplified Diagrams*) and theater dimming. If an external PWM signal is used, the theater-dimming effect can be achieved by varying the PWM duty cycle. Figure 1 shows a simple circuit that implements theater dimming with a DC input signal.

+5V Regulator

The MAX16804 includes a fixed +5V output regulator that delivers up to 2mA of load current throughout the 6.5V to 40V input voltage range. Connect a 0.1µF compensation capacitor from V5 to ground. Shorting V5 to ground disables the thermal shutdown. When EN is low, V5 is off. V5 stays on during PWM dimming.

Thermal Protection

The MAX16804 enters a thermal-shutdown mode in the event of overheating. This typically occurs in overload or short-circuit conditions on the output. If the junction temperature exceeds $T_J = +155^\circ\text{C}$ (typ), the internal thermal-protection circuitry turns off the series pass device. The MAX16804 recovers from thermal-shutdown mode once the junction temperature drops by 23°C (typ). The part therefore protects itself by thermally cycling in the event of a short-circuit or overload condition.

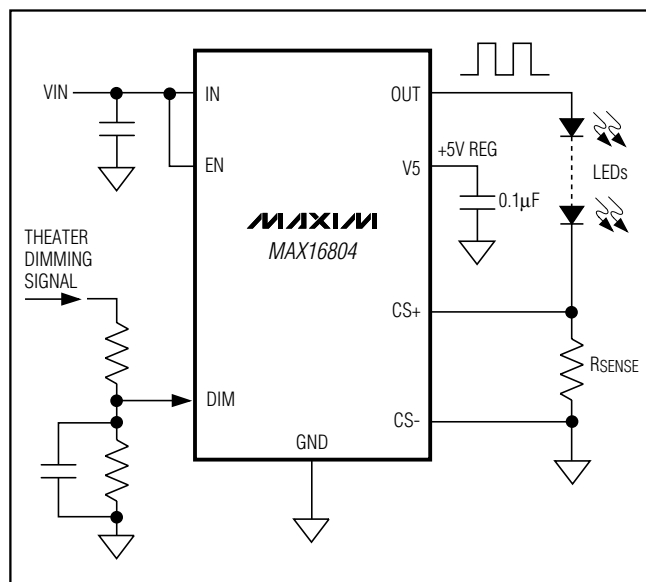

Figure 1. Theater Dimming

Applications Information

Programming the LED Current

The MAX16804 uses a sense resistor across CS+ and CS- to set the LED current. The differential sense amplifier connected across R_{SENSE} provides ground-loop immunity and low-frequency noise rejection. The LED current is given by

$$I_{LED} = V_{SENSE} / R_{SENSE} \quad (2)$$

Input-Voltage Considerations

For proper operation, the minimum input voltage must always be:

$$V_{IN(MIN)} \geq V_{RSENSE(MAX)} + V_{FT(MAX)} + \Delta V_{DO(MAX)} \quad (3)$$

where $V_{FT(MAX)}$ is the maximum forward voltage of all series connected LEDs and $\Delta V_{DO(MAX)}$ is the maximum drop output voltage. The minimum operating voltage of the device is +5.5V.

Two Brightness Levels for TAIL/STOP Lights

Figure 2 shows two-level brightness adjustment using the MAX16804 with minimum external components. Set the dimming level with a resistive divider connected to DIM. See Equation 1 for details.

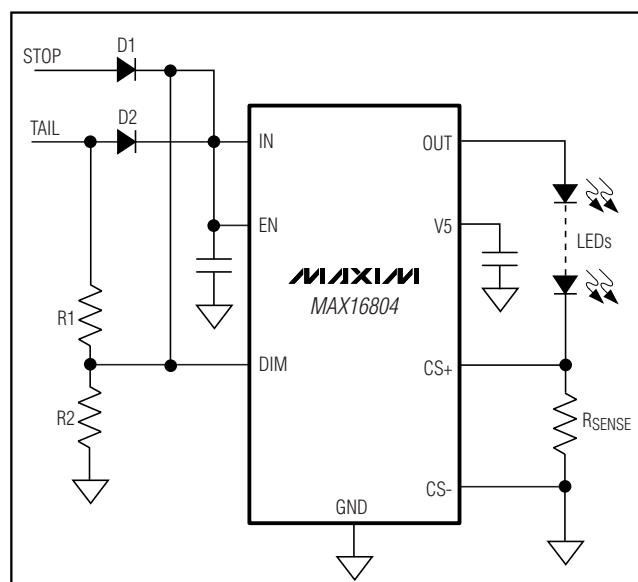

Figure 2. Two-Level Brightness Operation

High-Voltage, 350mA LED Driver with Analog and PWM Dimming Control

LED Current Thermal Foldback

With a minimum number of external components, the MAX16804 provides LED current thermal foldback using a negative temperature coefficient (NTC) thermistor. Figure 3 shows a thermistor connected to V5 and the CS+ of the MAX16804. As the temperature increases, the voltage drop across R2 increases causing the LED current to decrease.

$$I_{LED} = [V_{SENSE} - [R2 / (R2 + RT)] \times V5] / R1 \quad (4)$$

Other Applications

Figure 4 shows an application circuit with the MAX16804 using a single BJT to provide high output current. For proper operation:

$$V_{IN(MIN)} > V_{CESAT(MAX)} + V_{FT(MAX)} + V_{RSENSE} \quad (5)$$

where $V_{CESAT(MAX)}$ is the maximum saturation voltage of the external BJT.

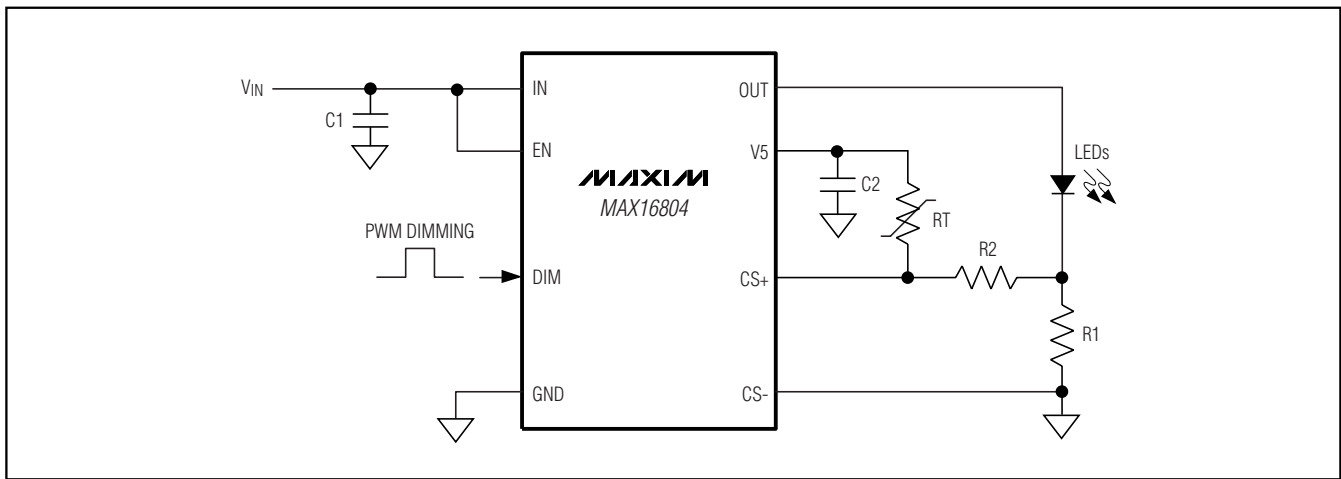

Figure 3. LED Current Thermal Foldback Operation with an NTC Thermistor

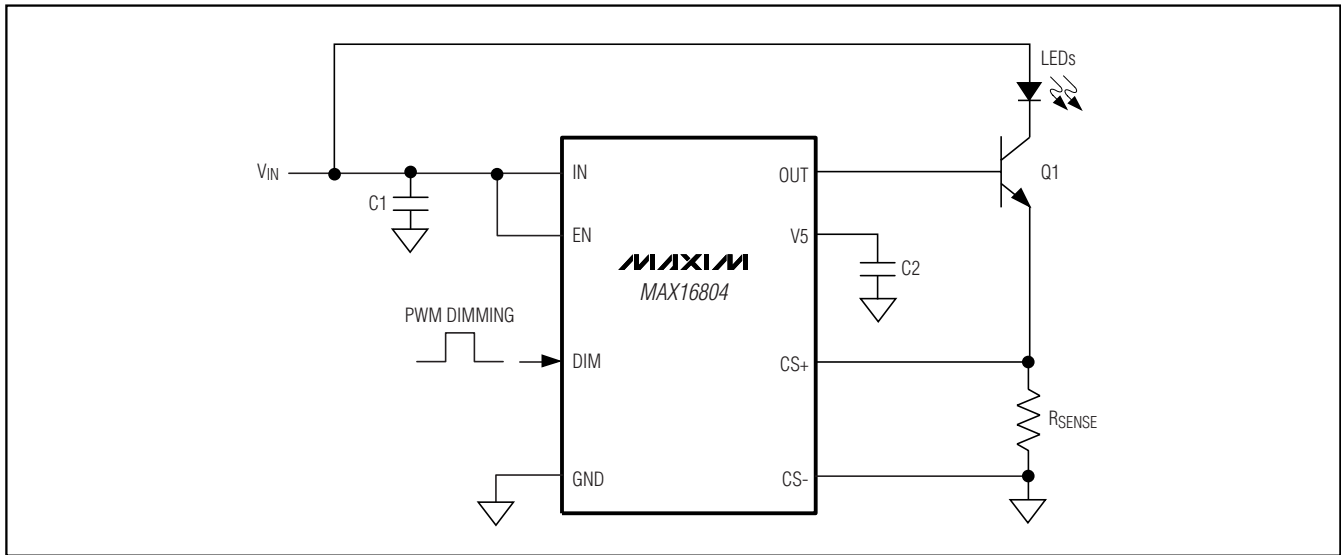
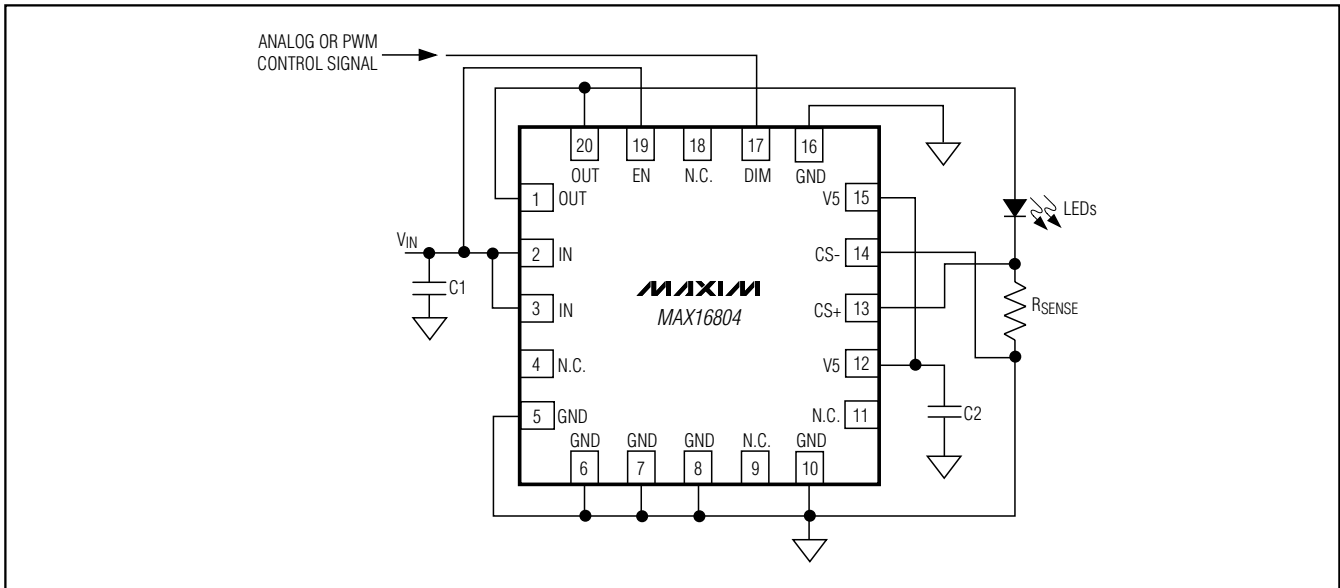

Figure 4. Increased Output Current (Amper Range) with a Single BJT

High-Voltage, 350mA LED Driver with Analog and PWM Dimming Control

Typical Operating Circuit



MAX16804

Pin Configuration

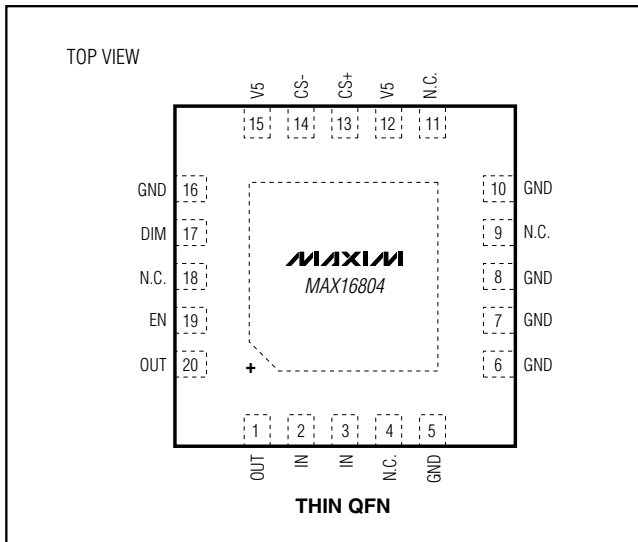

Chip Information

PROCESS: BICMOS

High-Voltage, 350mA LED Driver with Analog and PWM Dimming Control

Package Information

(The package drawing(s) in this data sheet may not reflect the most current specifications. For the latest package outline information go to www.maxim-ic.com/packages.)

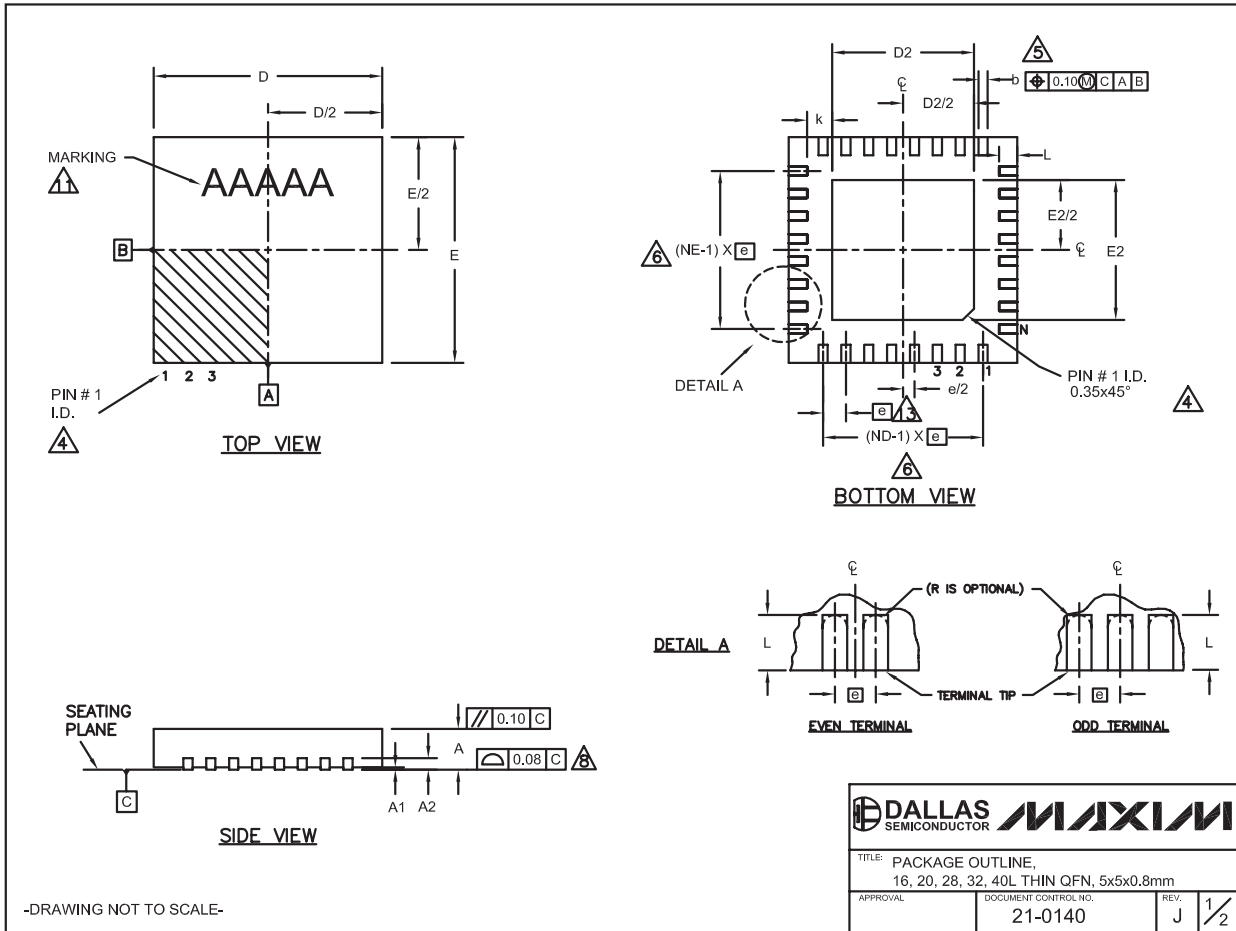

-DRAWING NOT TO SCALE-

TITLE: PACKAGE OUTLINE, 16, 20, 28, 32, 40L THIN QFN, 5x5x0.8mm	
APPROVAL	DOCUMENT CONTROL NO.
	21-0140
REV.	J 1/2

High-Voltage, 350mA LED Driver with Analog and PWM Dimming Control

Package Information (continued)

(The package drawing(s) in this data sheet may not reflect the most current specifications. For the latest package outline information go to www.maxim-ic.com/packages.)

MAX16804

COMMON DIMENSIONS															
PKG. SYMBOL	16L 5x5			20L 5x5			28L 5x5			32L 5x5			40L 5x5		
	MIN.	NOM.	MAX.	MIN.	NOM.	MAX.	MIN.	NOM.	MAX.	MIN.	NOM.	MAX.	MIN.	NOM.	MAX.
A	0.70	0.75	0.80	0.70	0.75	0.80	0.70	0.75	0.80	0.70	0.75	0.80	0.70	0.75	0.80
A1	0	0.02	0.05	0	0.02	0.05	0	0.02	0.05	0	0.02	0.05	0	0.02	0.05
A2	0.20 REF.			0.20 REF.			0.20 REF.			0.20 REF.			0.20 REF.		
b	0.25	0.30	0.35	0.25	0.30	0.35	0.20	0.25	0.30	0.20	0.25	0.30	0.15	0.20	0.25
D	4.90	5.00	5.10	4.90	5.00	5.10	4.90	5.00	5.10	4.90	5.00	5.10	4.90	5.00	5.10
E	4.90	5.00	5.10	4.90	5.00	5.10	4.90	5.00	5.10	4.90	5.00	5.10	4.90	5.00	5.10
e	0.80 BSC.			0.65 BSC.			0.50 BSC.			0.50 BSC.			0.40 BSC.		
k	0.25	-	-	0.25	-	-	0.25	-	-	0.25	-	-	0.25	-	-
L	0.30	0.40	0.50	0.45	0.55	0.65	0.45	0.55	0.65	0.30	0.40	0.50	0.30	0.40	0.50
N	16			20			28			32			40		
ND	4			5			7			8			10		
NE	4			5			7			8			10		
JEDEC	WHHB			WHHC			WHHD-1			WHHD-2			---		

EXPOSED PAD VARIATIONS						
PKG. CODES	D2			E2		
	MIN.	NOM.	MAX.	MIN.	NOM.	MAX.
T1655-2	3.00	3.10	3.20	3.00	3.10	3.20
T1655-3	3.00	3.10	3.20	3.00	3.10	3.20
T1655N-1	3.00	3.10	3.20	3.00	3.10	3.20
T2055-3	3.00	3.10	3.20	3.00	3.10	3.20
T2055-4	3.00	3.10	3.20	3.00	3.10	3.20
T2055-5	3.15	3.25	3.35	3.15	3.25	3.35
T2855-3	3.15	3.25	3.35	3.15	3.25	3.35
T2855-4	2.60	2.70	2.80	2.60	2.70	2.80
T2855-5	2.60	2.70	2.80	2.60	2.70	2.80
T2855-6	3.15	3.25	3.35	3.15	3.25	3.35
T2855-7	2.60	2.70	2.80	2.60	2.70	2.80
T2855-8	3.15	3.25	3.35	3.15	3.25	3.35
T2855N-1	3.15	3.25	3.35	3.15	3.25	3.35
T3255-3	3.00	3.10	3.20	3.00	3.10	3.20
T3255-4	3.00	3.10	3.20	3.00	3.10	3.20
T3255-5	3.00	3.10	3.20	3.00	3.10	3.20
T3255N-1	3.00	3.10	3.20	3.00	3.10	3.20
T4055-1	3.40	3.50	3.60	3.40	3.50	3.60
T4055-2	3.40	3.50	3.60	3.40	3.50	3.60

**SEE COMMON DIMENSIONS TABLE

NOTES:

- DIMENSIONING & TOLERANCING CONFORM TO ASME Y14.5M-1994.
- ALL DIMENSIONS ARE IN MILLIMETERS, ANGLES ARE IN DEGREES.
- N IS THE TOTAL NUMBER OF TERMINALS.
- THE TERMINAL #1 IDENTIFIER AND TERMINAL NUMBERING CONVENTION SHALL CONFORM TO JESD 95-1 SPP-012. DETAILS OF TERMINAL #1 IDENTIFIER ARE OPTIONAL, BUT MUST BE LOCATED WITHIN THE ZONE INDICATED. THE TERMINAL #1 IDENTIFIER MAY BE EITHER A MOLD OR MARKED FEATURE.
- DIMENSION b APPLIES TO METALLIZED TERMINAL AND IS MEASURED BETWEEN 0.25 mm AND 0.30 mm FROM TERMINAL TIP.
- ND AND NE REFER TO THE NUMBER OF TERMINALS ON EACH D AND E SIDE RESPECTIVELY.
- DEPOPULATION IS POSSIBLE IN A SYMMETRICAL FASHION.
- COPLANARITY APPLIES TO THE EXPOSED HEAT SINK SLUG AS WELL AS THE TERMINALS.
- DRAWING CONFORMS TO JEDEC MO220, EXCEPT EXPOSED PAD DIMENSION FOR T2855-3 AND T2855-6.
- WARPAGE SHALL NOT EXCEED 0.10 mm.
- MARKING IS FOR PACKAGE ORIENTATION REFERENCE ONLY.
- NUMBER OF LEADS SHOWN ARE FOR REFERENCE ONLY.
- LEAD CENTERLINES TO BE AT TRUE POSITION AS DEFINED BY BASIC DIMENSION "e", ±0.05.

-DRAWING NOT TO SCALE-

TITLE: PACKAGE OUTLINE, 16, 20, 28, 32, 40L THIN QFN, 5x5x0.8mm	
APPROVAL	DOCUMENT CONTROL NO. 21-0140
REV. J	2/2

Maxim cannot assume responsibility for use of any circuitry other than circuitry entirely embodied in a Maxim product. No circuit patent licenses are implied. Maxim reserves the right to change the circuitry and specifications without notice at any time.

Maxim Integrated Products, 120 San Gabriel Drive, Sunnyvale, CA 94086 408-737-7600 11