

## 200GHz WDM Filter Chips

Bookham narrowband filters leverage the proprietary Advanced Energetic Deposition (AED) process to produce the industry's best filter solutions. The AED process features state-of-the-art layer thickness control to produce thin-film interference filters for optical add/drop multiplexing (OADM) WDM applications and Mux/Demux.

Bookham offers a range of filtering solutions for 200GHz channel spacing. Filter designs can be optimized for transmission and reflection loss for mux/demux applications or offer deeper reflection notches for optical add/drop multiplexing (OADM).

### Features:

- C-band center wavelengths
- Accurate wavelength centering
- Deep reflection isolation
- High adjacent channel transmission isolation
- Flat transmission passband for cascading
- Excellent temperature stability

### Options:

- S & L-band center wavelengths
- Custom specifications

### Applications:

- Mux/Demux
- Optical add/drop multiplexing

### Compliance:

- GR-1221 qualified

- RoHS compliant 

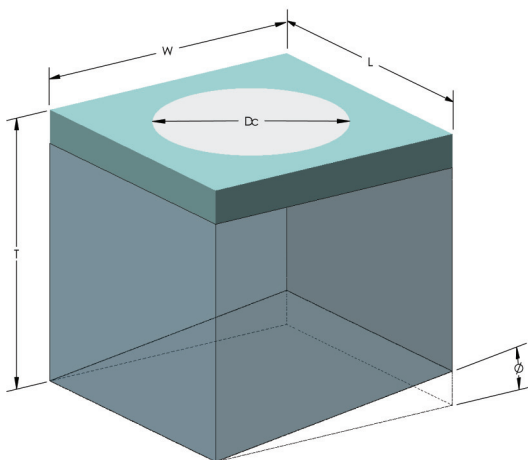

## 200GHz Filters:

Typical design specifications (valid over operating temperature)

Parameter	Standard Spec 0519	Spec 1079	Unit
Center Wavelength ( $\lambda_C$ )	C-band	C-band	nm
$\lambda_C$ Tolerance	ITU +0.3 to +0.65	ITU +0.3 to +0.65	nm
Transmission Bandwidth -0.3dB	N/A	0.8	min nm
Transmission Bandwidth -0.5dB	0.85	N/A	min nm
Transmission Bandwidth -30dB	2.4	2.6	max nm
Passband Loss Variation	0.3	0.2	max dB
Passband Loss Maximum	0.5	0.6	dB
Reflection Isolation	15	13	dB
PDL, Passband & Adj. Channel	0.08	0.08	max dB
Center Wavelength Temp Coefficient	1	1	max pm/C
Dimensions (L x W x T)	1.4 x 1.4 x 1.0	1.4 x 1.4 x 1.0	mm
Backside Wedge Angle ( $\Phi$ )	0.25	0.25	deg
Operating Temperature	-5 to 70		°C
Storage Temperature	-40 to 85		°C
Price for small quantities (in stock)	\$15 with a minimum of \$500 per order	\$15 with a minimum of \$500 per order	

All parameters tested at 0° angle of incidence.  
Edge chips <0.1mm.

## Example Performance

### 200GHz filter performance

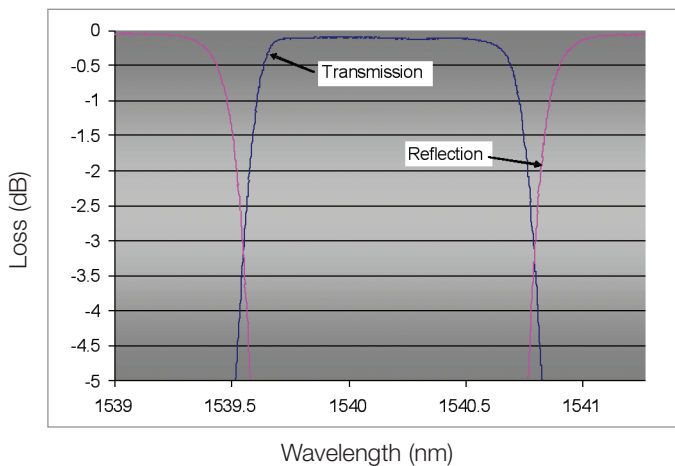

## RoHS Compliance



Bookham is fully committed to environment protection and sustainable development and has set in place a comprehensive program for removing polluting and hazardous substances from all of its products. The relevant evidence of RoHS compliance is held as part of our controlled documentation for each of our compliant products. RoHS compliance parts are available to order, please refer to the ordering information section for further details.

### Ordering Information:

100GHz Chip numbering convention

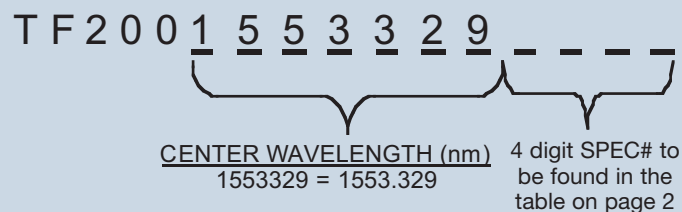

\$500 USD Minimum order

Specifications and wavelengths subject to stock on hand

\$5,000 USD minimum for orders requiring a coating run

## Contact Information

### North America

Bookham Santa Rosa  
3640 Westwind Blvd  
Santa Rosa  
CA 95403  
USA

- Tel: +1 707 636 1100
- Fax: +1 707 636 1199
- Email: [sales@bookham.com](mailto:sales@bookham.com)

### Europe

Bookham Paignton  
Brixham Road  
Paignton  
Devon  
TQ4 7BE  
United Kingdom

- Tel: +44 (0) 1803 66 2000
- Fax: +44 (0) 1803 66 2801
- Email: [sales@bookham.com](mailto:sales@bookham.com)

### Asia – Sales Representatives

**Luy Broadband**  
Beijing, China

- Tel: +86 10 6848 2508/2504
- Fax: +86 10 6848 5151
- Email: [james.zhang@LuY-tech.com](mailto:james.zhang@LuY-tech.com)

**Hana Enterprise**  
Suwon, S. Korea

- Tel: +82 31 204 3505
- Fax: +82 31 204 3506
- Email: [sein33@netian.com](mailto:sein33@netian.com)

### Astra

Tokyo, Japan

- Tel: +81 3 3490 3801
- Fax: +81 3 5434 9658
- Email: [iwaki@astrainc.co.jp](mailto:iwaki@astrainc.co.jp)

### Important Notice

Performance figures, data and any illustrative material provided in this data sheet are typical and must be specifically confirmed in writing by Bookham before they become applicable to any particular order or contract. In accordance with the Bookham policy of continuous improvement specifications may change without notice. The publication of information in this data sheet does not imply freedom from patent or other protective rights of Bookham or others. Further details are available from any Bookham sales representative.