

# 50GHz WDM Filter Chips

Bookham narrowband filters leverage the proprietary Advanced Energetic Deposition (AED) process to produce the industry's best filter solutions. The AED process features state-of-the-art layer thickness control to produce thin-film interference filters for optical add/drop multiplexing (OADM) WDM applications and Mux/Demux.

Bookham offers a range of filtering solutions for 50GHz channel spacing. Filter designs can be optimized for transmission and reflection loss for mux/demux applications or offer deeper reflection notches for optical add/drop multiplexing (OADM).

**Features:**

- C and L-band center wavelengths
- Accurate wavelength centering
- High adjacent channel transmission isolation
- Flat transmission passband for cascading
- Excellent temperature stability

**Options:**

- Custom specifications in stock

**Applications:**

- Mux/Demux
- Optical add/drop multiplexing
- Metro and long-haul DWDM

**Compliance:**

- GR-1221 qualified
- RoHS compliant 

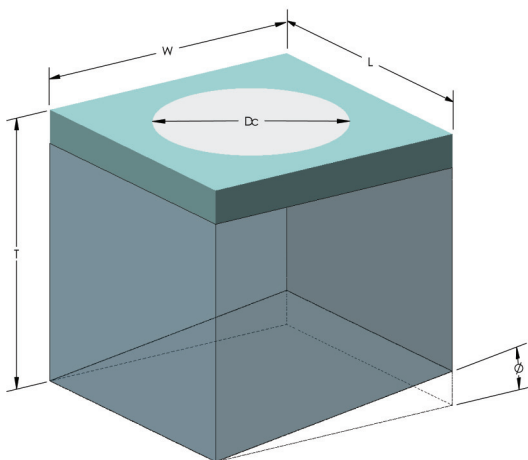

## 50GHz Filters:

Typical design specifications (valid over operating temperature)

Parameter	Spec 0134	Spec 0536	Unit
Center Wavelength ( $\lambda_c$ )	1530-1610	1530-1565	nm
$\lambda_c$ Tolerance	$\lambda_c + 0.03$	$\lambda_c + 0.05$	nm
Transmission Bandwidth -0.5dB	0.26	0.26	min nm
Transmission Bandwidth -25dB	0.58	0.58	max nm
Passband Loss Variation	0.5	0.5	max dB
Passband Loss Maximum	1.0	1.0	dB
Reflection Isolation	12.5 (over $\lambda_c + 0.08$ )	12.1 (over $\lambda_c + 0.135$ )	dB
PDL, Passband & Adj. Channel	0.1	0.1	max dB
Center Wavelength Temp Coefficient	0.5	0.5	max pm/C
Dimensions (L x W x T)	2.3 x 2.3 x 1.9		mm
Backside Wedge Angle ( $\Phi$ )	0.25		deg
Operating Temperature	-5 to 70		°C
Storage Temperature	-40 to 85		°C
Pricing for small quantities (in stock)	\$250/each (minimum \$500 per order)		

All parameters tested at 0° angle of incidence.  
Edge Chips <0.1mm

## Example Performance

### 50GHz filter performance

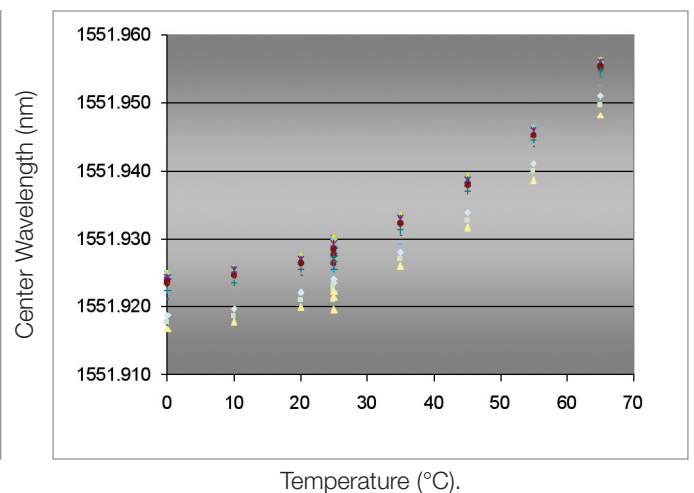
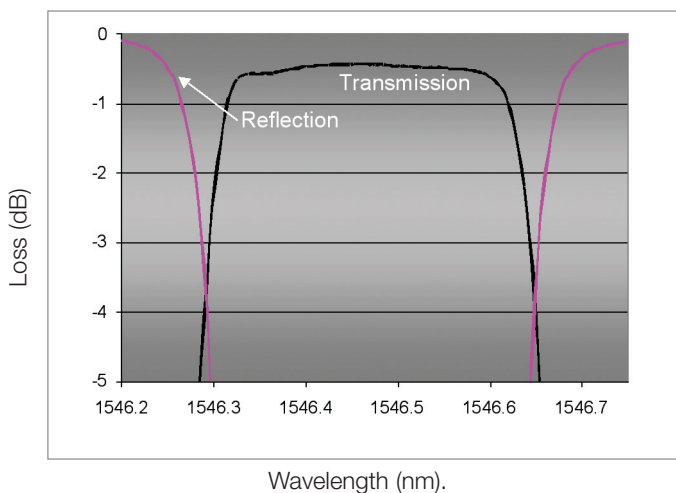

## RoHS Compliance

Bookham is fully committed to environment protection and sustainable development and has set in place a comprehensive program for removing polluting and hazardous substances from all of its products. The relevant evidence of RoHS compliance is held as part of our controlled documentation for each of our compliant products. RoHS compliance parts are available to order, please refer to the ordering information section for further details.

### Ordering Information:

50GHz Chip numbering convention

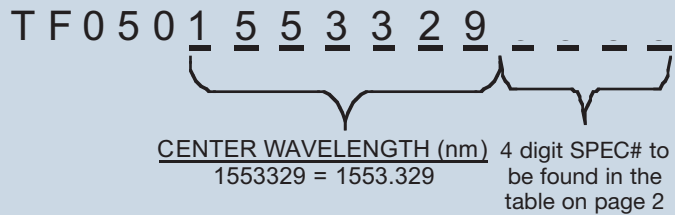

\$500 USD minimum order for parts in stock  
 Specifications and wavelengths subject to availability

## Contact Information

### North America

Bookham Santa Rosa  
 3640 Westwind Blvd  
 Santa Rosa  
 CA 95403  
 USA

- **Tel:** +1 707 636 1100
- **Fax:** +1 707 636 1199
- **Email:**  
[sales@bookham.com](mailto:sales@bookham.com)

### Europe

Bookham Paignton  
 Brixham Road  
 Paignton  
 Devon  
 TQ4 7BE  
 United Kingdom

- **Tel:** +44 (0) 1803 66 2000
- **Fax:** +44 (0) 1803 66 2801
- **Email:**  
[sales@bookham.com](mailto:sales@bookham.com)

### Asia – Sales Representatives

**Luy Broadband**  
 Beijing, China

- **Tel:** +86 10 6848 2508/2504
- **Fax:** +86 10 6848 5151
- **Email:**  
[james.zhang@LuY-tech.com](mailto:james.zhang@LuY-tech.com)

**Hana Enterprise**  
 Suwon, S. Korea

- **Tel:** +82 31 204 3505
- **Fax:** +82 31 204 3506
- **Email:**  
[sein33@netian.com](mailto:sein33@netian.com)

### Astra

Tokyo, Japan  
 • **Tel:** +81 3 3490 3801  
 • **Fax:** +81 3 5434 9658  
 • **Email:**  
[iwaki@astrainc.co.jp](mailto:iwaki@astrainc.co.jp)

### Important Notice

Performance figures, data and any illustrative material provided in this data sheet are typical and must be specifically confirmed in writing by Bookham before they become applicable to any particular order or contract. In accordance with the Bookham policy of continuous improvement specifications may change without notice. The publication of information in this data sheet does not imply freedom from patent or other protective rights of Bookham or others. Further details are available from any Bookham sales representative.