



**POWER MANAGEMENT**
**Absolute Maximum Ratings**

Exceeding the specifications below may result in permanent damage to the device or device malfunction. Operation outside of the parameters specified in the Electrical Characteristics section is not implied.

Parameter	Symbol	Maximum	Units
VCC, CTO, NTC to GND		-0.3 to 14.0	V
VOUT, BSEN, RTIM, AFC, IPRGM, CPB, CHRGB, OVPB, ITERM, FLTB, to GND		-0.3 to +6.0	V
RGND to GND		-0.3 to 0.3	V
VOUT Output Current	$I_{VOUT}$	1.5	A
Power Dissipation MLP (Derate 20mW/°C above 85°C)	$P_d$	2	W
Thermal Impedance, Junction to Ambient <sup>(1)</sup>	$\theta_{JA}$	48	°C/W
Junction Temperature	$T_J$	150	°C
Operating Ambient Temperature Range	$T_A$	-40 to +85	°C
IR Reflow Temperature	$T_{LEAD}$	260	°C
Storage Temperature Range	$T_{STG}$	-65 to 150	°C
VOUT short to GND		Continuous	
ESD Protection Level <sup>(2)</sup>	$V_{ESD}$	2	kV

Notes:

- 1) Calculated from package in still air, mounted to 3" x 4.5", 4 layer FR4 PCB with thermal via under the exposed pad per JESD51 standards.
- 2) Tested according to JEDEC standard JESD22-A114-B.

**Electrical Characteristics**

Unless otherwise noted: VCC = 4.75V - 5.25V. Typical values are at  $T_A = 25^\circ\text{C}$  Min and Max are for  $-40^\circ\text{C} < T_A < +85^\circ\text{C}$  unless noted.

Parameter	Symbol	Conditions	Min	Typ	Max	Units
Operating Voltage	$VCC_{OP}$		4.2	5.0	6.1 <sup>(1)</sup>	V
VCC UVLO Rising Threshold	$VT_{UVLOR}$	Charging begins when threshold is exceeded	3.8	4.0	4.2	V
VCC UVLO Falling Threshold	$VT_{UVLOF}$	Charging continues until threshold is reached	2.8	3.0	3.2	V
VCC OVP Rising Threshold	$VT_{OVPR}$		6.5	6.8	7.25	V
VCC OVP Falling Threshold	$VT_{OVPF}$		6.1	6.5	6.85	V
VCC OVP Hysteresis	$VT_{OVPH}$		200	350	600	mV
Operating Current	$ICC_{DIS}$	Shutdown Mode - CHRGB, CPB, OVPB, FLTB off NTC = 0V		1.9		mA
	$ICC_{CHG}$	Charging Mode - CHRGB, CPB, OVPB, FLTB off NTC = 2.5V		2.0		

**POWER MANAGEMENT**
**Electrical Characteristics (Cont.)**

Parameter	Symbol	Conditions	Min	Typ	Max	Units
Battery Leakage Current (VOUT and BSEN)	$I_{LEAK_{BAT}}$	$V_{CC} = 0V$ , $V_{OUT} = BSEN = 4.5V$		0.1	2	$\mu A$
Regulated Constant Voltage	$V_{CV}$	$0^{\circ}C \leq T_J \leq 125^{\circ}C$	4.16	4.20	4.24	V
RGND Output Accuracy $V_{OUT} = V_{OUT_{NOM}} + \Delta RGND$	$V_{RGND}$	$RGND - GND = 30mV$	22	30	38	mV
RGND Current	$I_{RGND}$	$RGND = 0V$		35		$\mu A$
Battery Pre-Charge Current	$I_{PREQ}$	$R_{ITERM} = 499\Omega$ , $0^{\circ}C \leq T_J \leq 125^{\circ}C$	270	300	330	mA
Battery Termination Current	$I_{TERM}$	$R_{ITERM} = 499\Omega$ , $0^{\circ}C \leq T_J \leq 125^{\circ}C$	270	300	330	mA
Battery Fast-Charge Current	$I_{FAST}$	$R_{PRGM} = 1.87k\Omega$ , $V_{OUT} = 3.8V$ $0^{\circ}C \leq T_J \leq 125^{\circ}C$	740	800	860	mA
AFC DAC Fast-Charge Current	$I_{DACADJ}$	$R_{PRGM} = 1.87k\Omega$ , $V(AFC) = 0.75V$ $0^{\circ}C \leq T_J \leq 125^{\circ}C$	360	400	440	mA
AFC Enable/Disable Threshold	$V_{T_{AFC}}$	$V_{CC} - V_{AFC} > V_{T_{AFC}}$ disables Analog Fast Charge		1		V
ITERM Regulated Voltage	$V_{ITERM}$		1.4	1.5	1.6	V
I PROG Regulated Voltage	$V_{IPRGM}$		1.4	1.5	1.6	V
$V_{BAT}$ Pre-Charge Threshold	$V_{T_{PreQ}}$	$0^{\circ}C \leq T_J \leq 125^{\circ}C$	2.8	2.9	3.0	V
$V_{BAT}$ Recharge Threshold	$V_{T_{ReQ}}$	$V_{CV} - V_{BSEN}$ , $0^{\circ}C \leq T_A \leq 85^{\circ}C$	60	100	140	mV
Over-Temperature Shutdown	$T_{OT}$	Hysteresis = $10^{\circ}C$		150		$^{\circ}C$

**POWER MANAGEMENT**
**Electrical Characteristics (Cont.)**

Parameter	Symbol	Conditions	Min	Typ	Max	Units
NTC Thresholds	$V_{T_{NTCDIS}}$	SC804 Disabled	0.3	0.6	0.8	V
	$V_{T_{NTCH}}$	NTC Hot $V_{TH}$ Applies to falling threshold $4.3V \leq V_{CC} \leq 6.5V$	29	30	31	% of VCC
		at $V_{CC} = 5V$	1.45	1.50	1.55	V
	$V_{T_{NTCC}}$	NTC Cold $V_{TH}$ , $V_{CTO} = 0V$ Applies to rising threshold $4.3V \leq V_{CC} \leq 6.5V$	73.4	74.4	75.4	% of VCC
		at $V_{CC} = 5V$	3.67	3.72	3.77	V
	$V_{T_{NTCHYS}}$	NTC Hot & Cold $V_{T_{NTCx}}$ hysteresis ( $V_{T_{NTCx}}$ Rising - $V_{T_{NTCx}}$ Falling) Applies to internal NTC thresholds		50		mV
	$V_{CTO}$	CTO Voltage (Adjustable NTC Cold Rising Threshold) Setting Range <sup>(2)</sup> , $-40^{\circ}C \leq T_A \leq 25^{\circ}C$ (NTC Cold Rising Threshold is $V_{T_{NTCC}}$ when CTO tied to GND)	50		90	% of VCC
		Threshold Error <sup>(3)</sup> , $-40^{\circ}C \leq T_A \leq 25^{\circ}C$	-70		70	mV
$V_{T_{CTOHYS}}$	Internal hysteresis on CTO ( $V_{CTO}$ Rising - $V_{CTO}$ Falling) Applies to externally set NTC cold threshold		50		mV	
Adjust Mode BSEN Voltage	$V_{BSEN-ADJ}$	$3.5V \leq V_{OUT} \leq V_{CC} - 150mV$ $0^{\circ}C \leq T_J \leq 125^{\circ}C$	3.072	3.11	3.134	V
Adjust Mode Enable Voltage, VOUT-BSEN	$V_{ADJEN}$	$3.5V \leq V_{OUT} \leq V_{CC} - 150mV$			400	mV
Adjust Mode Disable Voltage, VOUT-BSEN	$V_{ADJDIS}$	$3.5V \leq V_{OUT} \leq V_{CC} - 150mV$	150			mV

**POWER MANAGEMENT**
**Electrical Characteristics (Cont.)**

Parameter	Symbol	Conditions	Min	Typ	Max	Units
External RTIM Regulation Voltage	$V_{RTIM}$	$R_{RTIM} = 37.4k\Omega$	1.4	1.5	1.6	V
Timer Disable Threshold	$V_{T_{TIMER}}$	$V_{RTIM} \leq V_{T_{TIMER}}$ disables internal timer	0.65	0.85		V
Internal Timer Select	$V_{T_{INTTS}}$	$V_{CC} - V_{RTIM} > V_{T_{INTTS}}$ selects internal timer		1.1		V
Pre-Charge Fault Time-Out	$T_{PreQF}$	$R_{RTIM} = 37.4k\Omega$ RTIM pulled to VCC	-20% -35%	53 45	+20% +35%	min
Complete Charge Time-Out	$T_{QCOMP}$	$R_{RTIM} = 37.4k\Omega$ RTIM pulled to VCC	-20% -35%	3.5 3.0	+20% +35%	hr
CHRGB On	$V_{CHRGB}$	Load = 5mA		0.5	1	V
CHRGB Off	$I_{CHRGB}$	Leakage Current, V = 5V			1	$\mu A$
CPB On	$V_{CPB}$	Load = 5mA		0.5	1	V
CPB Off	$I_{CPB}$	Leakage Current, V = 5V			1	$\mu A$
OVPB On	$V_{OVPB}$	Load = 5mA		0.5	1	V
OVPB Off	$I_{OVPB}$	Leakage Current, V = 5V			1	$\mu A$
FLT B On	$V_{FLT B}$	Load = 5mA		0.5	1	V
FLT B Off	$I_{FLT B}$	Leakage Current, V = 5V			1	$\mu A$

**Notes:**

- 1)  $V_{CC_{op}}$  Max is the "Maximum Vsupply" as defined in EIA/JEDEC Standard No. 78, paragraph 2.11.
- 2) The absolute voltage on CTO must not exceed 6.0V to ensure normal operation.
- 3) The threshold error is tested at  $V_{CTO}$  min and max only.

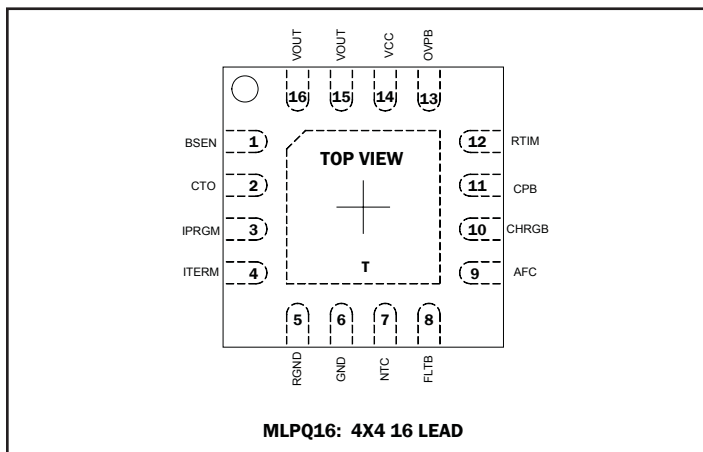
**POWER MANAGEMENT**
**Pin Configuration**

**Ordering Information**

DEVICE	PACKAGE
SC804IMLTRT <sup>(1)</sup>	MLPQ -16 <sup>(2)</sup>
SC804EVB	Evaluation Board

**Notes:**

- 1) Available in tape and reel packaging only. A reel contains 3000 devices.
- 2) Available in lead-free packaging only. This product is fully WEEE and RoHS compliant.

**Pin Descriptions**

Pin #	Pin Name	Pin Function
1	BSEN	Battery voltage sense. Connect to battery positive terminal for Kelvin voltage sensing, VOUT otherwise. Do not leave open.
2	CTO	Cold Temperature Offset. Adjustable NTC input high voltage (cold temperature) threshold. When the pin is connected to GND the NTC high voltage threshold defaults to $V_{T_{NTCC}} \times V_{VCC}$ .
3	IPRGM	Charger current program pin for fast-charge mode. Requires a resistor to GND to program fast-charge current.
4	ITERM	Charger termination current program pin. Requires a resistor to GND to program pre-charge and termination current.
5	RGND	Reference ground. Connect to battery's negative terminal for Kelvin voltage sensing, GND otherwise. Do not leave open.
6	GND	Ground.
7	NTC	Input for battery NTC thermistor network. Voltage between $V_{T_{NTCH}} \times V_{VCC}$ , normally the hot threshold, and the CTO voltage ( $V_{T_{NTCC}} \times V_{VCC}$ if CTO is tied to GND), normally the cold threshold, enables charging. Voltages outside this range suspend charging and drive FLTB pin active (low). Voltage below $V_{T_{NTCDIS}}$ (nominally 0.6V) disables the SC804 and resets the charge timer (with FLTB pin inactive).
8	FLTB	Open drain fault indicator. Active low when a fault condition occurs.
9	AFC	Analog Fast Charge input. Connect to a DAC for analog control of fast charge current level, connect to VCC to disable this feature. Do not leave open.
10	CHRGB	Open drain charge status indicator. Active low when the charger is on and the output current exceeds the termination current setting, high impedance when $I_{VOUT} < ITERM$ .
11	CPB	Open drain charger-present indicator. Active low when VCC exceeds UVLO.
12	RTIM	Programmable timer input pin. Connect to VCC to select the default time-out of 3 hours, connect to GND to disable timer, or connect an external resistor to GND to program the time-out period.
13	OVPB	Open drain over-voltage indicator. Active low when an input over-voltage fault occurs.
14	VCC	Input supply pin. Connect to adapter power.
15	VOUT	Charger output. Connect to battery.
16	VOUT	Charger output. Connect to battery.
T	THERMAL PAD	Thermal-conduction pad on bottom of the package. Solder directly to the ground plane with multiple thermal vias to all other ground planes.

POWER MANAGEMENT

Block Diagram

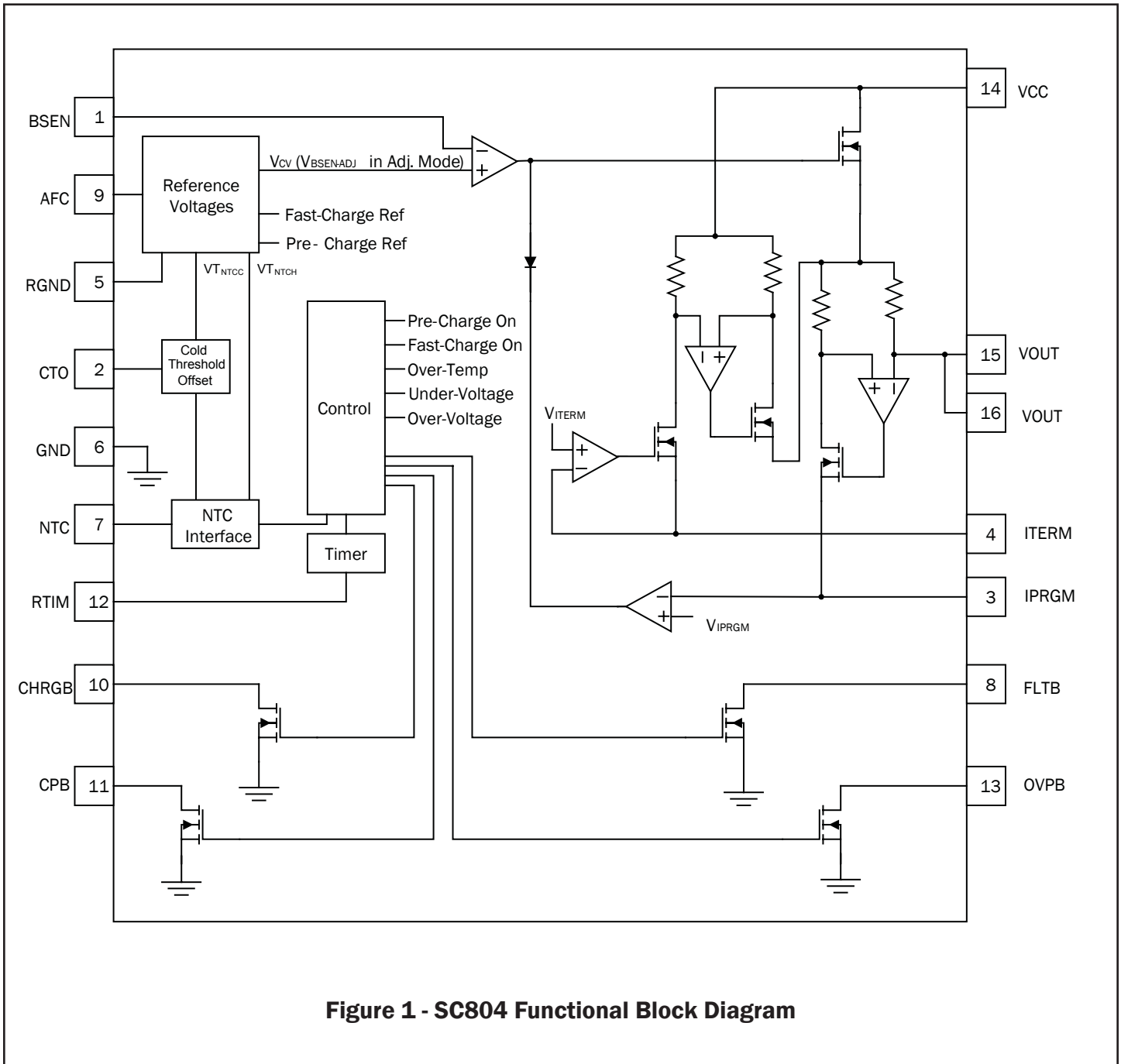

Figure 1 - SC804 Functional Block Diagram

### General Operation

The SC804 can be configured independently with respect to fast-charge and termination current, output voltage, and timing, depending on the application. A typical charging cycle is described below. Details on alternative applications and output programmability are covered in the individual sections.

The charging cycle begins when the power adapter is connected to the device. The SC804 performs glitch filtering on the VCC input and initiates a charge cycle when  $V_{VCC}$  is greater than the under-voltage lockout (UVLO) rising threshold voltage. If the battery voltage is less than the pre-charge threshold level, the SC804 will output the pre-charge current. Once the pre-charge threshold voltage is exceeded, the SC804 enters fast-charge constant current (CC) mode. When the battery voltage reaches its final value, the charger enters the constant voltage (CV) mode. In this mode the output current decreases as the battery continues to charge until the termination current level is reached. The CHRGB output turns off when IOUT drops below the termination current. If the charge timer is active, the SC804 continues to hold the battery in CV charge mode until the timer expires. When the timer expires the charger enters the monitor mode where the output remains off until the voltage at VOUT drops by  $V_{T_{ReQ}}$ . At this point a new charge cycle is initiated.

### Pre-Charge Mode

Pre-charge mode is automatically enabled whenever the battery voltage is below the pre-charge threshold voltage,  $V_{T_{PreQ}}$ . It is used to limit the power dissipation and precondition the battery for fast charging. The pre-charge current value is determined by the resistor on the ITERM pin. The pre-charge current is programmable from 50mA to 350mA. The equation to select the pre-charge current is given by:

$$PCI = \frac{V_{ITERM\_Typ}}{R_{ITERM}} \times 100$$

Where  $V_{ITERM\_Typ}$  designates the typical value of  $V_{ITERM}$ . When the timer is enabled there is also a maximum allowed pre-charge duration. If the pre-charge time exceeds 25% of the total charge cycle the charger will turn off due to a pre-charge fault. This fault is cleared when VCC is toggled or the output voltage rises above  $V_{T_{PreQ}}$ .

### Fast-Charge Mode (CC)

The fast-charge CC (Constant Current) mode is active when the battery voltage is above  $V_{T_{PreQ}}$  and less than  $V_{CV}$ . The fast-charge current can be set to a maximum of 1.5A and is selected by the program resistor on the IPRGM pin. The voltage on this pin will represent the current through the battery, enabling a microprocessor via an analog-to-digital converter (ADC) to monitor battery current by sensing the voltage on the IPRGM pin. The equation to set the fast-charge current is given by:

$$FCI = \frac{V_{IPRGM\_Typ} \times 1000}{R_{IPRGM}}$$

The superior fast-charge current accuracy of the SC804 is obtained by use of a patented\* polarity-switched (i.e., chopped) current sense amplifier to nullify current measurement offset errors.

Compliance with the absolute maximum output current  $I_{VOUTMAX}$ , allowing for current regulation tolerance, requires that  $R_{IPRGM}$  be no smaller than 1.05k $\Omega$  nominal.  $R_{IPRGM}$  can be as large as 11.5k $\Omega$ , for a nominal FCI as small as 130mA, but must exceed PCI by at least 80mA. Note that for a given program resistor the current through the battery in CV mode can be determined by replacing  $V_{IPRGM\_Typ}$  with the actual voltage on the IPRGM pin in the above equation. The CC current can also be modified by applying an analog voltage to the AFC pin as described below.

### Analog Fast Charge (AFC Pin)

Many applications require more than one current setting for fast-charge. This behavior is obtained in the SC804 using the AFC function. When the AFC pin is connected to VCC the device behaves as described in the previous section. When the AFC pin is driven by an analog voltage between 0V and  $(V_{VCC}-1.0)V$ , the SC804 automatically uses this pin voltage to set the maximum fast-charge current according to the following equation:

$$FCI = \frac{V_{AFC}}{R_{IPRGM}} \times 1000$$

\*US Patent 6,836,095.



**POWER MANAGEMENT**
**Applications Information**

This adjustment to the fast charge current is obtained by replacing the fixed  $V_{IPRGM}$  reference voltage with the AFC voltage. (Note that AFC voltages above  $V_{IPRGM}$  will produce  $I_{VOUT}$  exceeding that programmed as per the Fast-Charge Mode (CC) section.) For any applied AFC voltage, FCI must not drop below 130mA, and FCI must always remain at least 80mA greater than PCI.

**Termination Current**

Once the battery voltage reaches  $V_{CV}$  the SC804 will transition from constant current mode to constant voltage mode. The current through the battery will decrease while the voltage remains constant as the battery becomes fully charged. When the current falls below the programmed termination current set by the termination resistor connected to the ITERM pin, the SC804 will disable CHRGB. If the timer is enabled the output will continue to float-charge in CV mode until the timer expires. If the timer is disabled, the output will turn off as soon as the termination current level is reached. The equation to set the termination current is given by:

$$I_{TERM} = \frac{V_{I_{TERM\_Typ}}}{R_{I_{TERM}}} \times 100$$

$I_{TERM}$  can be programmed to be as high as 300mA or as low as 50mA, though accuracy is not guaranteed below 100mA.  $I_{TERM}$  must be programmed to be less than FCI for correct operation of the charge cycle.

**Monitor Mode**

When a charge cycle is complete, the SC804 output turns off and the device enters monitor mode. If the voltage of the battery falls below the recharge threshold ( $V_{CV} - V_{ReQ}$ ), the charger will clear the charge timer and re-initiate a charge cycle. The maximum current drain of the battery during monitor mode will be no more than 1 $\mu$ A over temperature. The status of the charger output as a function of the timer and IOUT is tabulated below.

Timer	Iout	Output State
T < Timeout	N/A	On
T > Timeout	N/A	Off
Disabled	< Itermination	Off

**Charge Timer**

The timer on the SC804 has two functions: to protect in the event of a faulty battery and to maximize charging capacity. The RTIM pin is connected to VCC to select the internal timer, and to GND to disable the timer.

Connecting a resistor between RTIM and GND will program the total charge time according to the following equation:

$$\text{Charge time} = \left( \frac{R_{RTIM}}{3} \right) \times \frac{1}{3600}$$

with charge time expressed in hours. The timer is programmable over the range of 2 to 6 hours. The internal timer selection results in a charge time of 3 hours. The SC804 will automatically turn off the output when the charge timer times out.

**NTC Interface**

The NTC pin provides an interface to a battery pack Negative Temperature Coefficient (NTC) thermistor. The typical NTC network has a fixed resistor from VCC to the NTC pin, and the battery pack NTC thermistor connected from the NTC pin to ground. In this configuration, an increasing battery temperature produces a decreasing NTC pin voltage, and a decreasing battery temperature produces an increasing NTC pin voltage.

This configuration is shown in the typical application schematic on page 1 of this datasheet. When the NTC voltage from the divider is greater than the high (cold) threshold or less than the low (hot) threshold, the SC804 suspends the charge cycle by turning off the output, halting (but not resetting) the charge timer, and indicating a fault on the FLTB pin. Hysteresis is included for both high and low NTC thresholds to avoid chatter at the NTC trip points. When the NTC pin voltage returns to the valid range, the SC804 automatically resumes the charge cycle. The charge timer will time-out when the SC804 output on-time exceeds the timer setting regardless of how long it has been disabled due to the NTC temperature.

An input voltage between  $V_{NTCH} \times V_{VCC}$  and the CTO input voltage  $V_{CTO}$  ( $V_{NTCC} \times V_{VCC}$  if CTO is tied to GND) enables charging. An input voltage outside this range suspends charging and drives FLTB pin active (low). The internal NTC thresholds of  $V_{NTCH}$  and  $V_{NTCC}$  were designed to

**POWER MANAGEMENT**
**Applications Information (Cont.)**

work with standard thermistors available from numerous vendors.

NTC pin voltage below  $V_{T_{NTCDIS}}$  (nominally 0.6V) disables the SC804 and resets the charge timer (with the FLTB pin inactive). The NTC pin can be pulled down to ground by an external n-channel FET transistor or processor GPIO to disable or reset the SC804.

Note that the response of the SC804 to NTC pin voltage above the high threshold and below the low threshold is the same. Thus it is possible to configure the NTC network with the battery pack thermistor between NTC and VCC, and a fixed resistor between NTC and ground. This configuration may be useful if it is desired to reset the charge timer (and the CHRGB output) when the battery pack is removed (so the fixed resistor pulls the NTC pin to ground) while VCC is present.

**Cold Temperature Offset (CTO)**

The voltage applied to the CTO pin sets the NTC high voltage (normally the cold temperature threshold) for the NTC input. The default NTC high threshold ( $V_{T_{NTCC}} \times V_{VCC}$ ) can be selected by connecting the CTO pin to ground. If it is desired to change this threshold, the voltage on the CTO pin can be set between  $0.5 \times V_{VCC}$  and  $0.9 \times V_{VCC}$ .

This feature is especially useful if a single PCB design is needed to satisfy similar applications with different requirements. The temperature range for normal charging can be adjusted by adjusting resistor values on a divider network without changing the NTC thermistor, which is often enclosed in the battery pack. An example of a typical application is shown in Figure 2.

**NTC/CTO Design Example**

The following example assumes the NTC network configuration of Figure 2, with a fixed resistor R3 connected between NTC and VCC, and a battery NTC thermistor RT connected between NTC and ground. The battery temperature range over which charging is permitted is specified to be 0°C through 40°C. The datasheet for the selected NTC thermistor indicates that  $R_T = 5.839k\Omega$  at 40°C, at  $R_T = 26.49k\Omega$  at 0°C, with a dissipation constant  $DC = 3mW$ . Designate  $R_{HOT} = 5.839k\Omega$  and  $R_{COLD} = 26.49k\Omega$ .

**Step 1:** *Select R3.* For the normal (NTC thermistor to ground) configuration, solve the NTC network voltage divider for R3 to place the NTC voltage at  $0.3 \times V_{CC}$  when  $R_T = R_{HOT}$ .

$$0.3 \times V_{CC} = \frac{V_{CC} \times R_{HOT}}{R3 + R_{HOT}}$$

or  $R3 = 2.333 \times R_{HOT} = 13.624k\Omega$  exactly. The closest 1% standard nominal value is  $R3 = 13.7k\Omega$ .

**Step 2:** *Verify acceptable thermistor self heating.* In general, lower values of  $R_T$  provide more noise immunity for the NTC voltage, but at the expense of bias current from the input adapter and power dissipation in the NTC network. The dissipation constant is the power rating of the thermistor resulting in a 1°C self heating error. The greatest self-heating occurs at low thermistor resistance (at high temperature). Since temperature sensing accuracy matters only at the charging temperature range thresholds, self heating is assessed only at the worst case high temperature threshold of +40°C.

For  $V_{VCC} = 5V$ , the 40°C NTC network current  $I_{NTC\_HOT} = V_{VCC} / (R3 + R_{HOT}) = 0.246mA$ . Power dissipation in the thermistor at this temperature,  $P_{HOT} = R_{HOT} \times (I_{NTC\_HOT})^2 = 0.38mW$ , for self heating of approximately 0.13°C. The actual high temperature threshold will thus be lower by 0.13°C. This self-heating error is usually acceptable. If it is not, then a thermistor with a greater  $R_{HOT}$  must be chosen.

**Step 3:** *Determine the desired high (cold) threshold.* Compute the NTC network resistor divider voltage, as a function of  $V_{VCC}$ , at the cold temperature threshold.

$$NTC_{COLD} = \frac{V_{CC} \times R_{COLD}}{R3 + R_{COLD}} = 0.6591 \times V_{CC}$$

**Step 4:** *Configure CTO.* If  $NTC_{COLD}$  is sufficiently close to the default cold threshold ( $V_{T_{NTCC}} \times V_{VCC}$ ), then simply connect CTO to ground, disabling the CTO function, to complete the design. But in this example it is not, so the voltage on CTO must be set to  $0.6591 \times V_{VCC}$ . The simple resistive voltage divider network of Figure 2 can be used to obtain the desired CTO voltage.

**POWER MANAGEMENT**
**Applications Information (Cont.)**

$$V_{CTO} = NTC_{COLD}$$

$$= 0.6591 \times VCC = \frac{VCC \times R_{CT2}}{R_{CT1} + R_{CT2}}$$

or

$$\frac{R_{CT1}}{R_{CT2}} = \frac{1 - 0.6591}{0.6591} = 0.5172$$

The choice of  $R_{CT1}$  and  $R_{CT2}$  is somewhat arbitrary. The simplest approach is to pick one and compute the other. A good choice here is  $R_{CT1} = 115k\Omega$ , and  $R_{CT2} = 221k\Omega$ , as these standard 1% tolerance values produce the closest match to the desired voltage divider ratio. With these resistor nominal values,

$$V_{CTO} = \frac{VCC \times R_{CT2}}{R_{CT1} + R_{CT2}} = 0.6577 \times VCC$$

which is, nominally, only 0.2% below the target value of  $0.6591 \times V_{VCC}$ . The CTO network will present a load of only  $15\mu A$  to a 5V charging adapter. The nominal impedance presented to the CTO pin is  $R_{CT1} || R_{CT2} = 75.6k\Omega$ . Any impedance on the order of  $100k\Omega$  (or less) is acceptable.

### Remote Kelvin Sensing at the Battery

The BSEN pin provides the positive Kelvin sensing voltage feedback to the CV amplifier and should be connected as close to the battery + terminal as possible. Likewise, the RGND pin should be connected directly to the negative terminal of the battery. This allows the designer great flexibility in PCB layout and achieves greater accuracy by sensing the battery voltage directly at the battery terminals. When laying out the PCB, the designer should route the BSEN and RGND trace directly to the battery connection terminals, rather than just to the VOUT and GND pins on the device.

### Dropout Voltage

Dropout voltage is the smallest achievable difference voltage between VCC and VOUT under a particular operating condition. Dropout voltage is encountered

during CC charging whenever the current limit of the charging adapter is less than the SC804 FCI programmed current. In this case, the adapter voltage (the SC804 input voltage) will be pulled down to the battery voltage (the SC804 output voltage) plus the dropout voltage.

Dropout voltage is the larger of two values: (1) the I-R component, which is the output current multiplied by the minimum VCC-to-VOUT path resistance (which is highly temperature dependent), and (2) a regulated minimum difference voltage, which is output voltage dependent but is independent of the output current. The regulated minimum dropout voltage results from the collapse of internal voltage references as VOUT pulls VCC down to near, or below,  $V_{CV}$ , creating a reduced output regulation voltage approximately 200mV below VCC. Thus VCC cannot be pulled down below  $VOUT + 200mV$ . The dropout voltage will be larger than 200mV whenever the minimum path resistance multiplied by the output current exceeds 200mV, but it cannot be smaller than 200mV.

This greatest-of-two-limit dropout voltage behavior is evident in the dropout voltage typical performance plot.

When operating in Adjust Mode (next section), the regulated minimum dropout voltage depends on the programmed VOUT regulation voltage, and dropout also varies with the actual output voltage during CC charging. See Figure 4 for an illustration of dropout voltage data.

### Adjust Mode

The SC804 can be configured for an output voltage other than  $V_{CV}$  using Adjust (ADJ) Mode. In Adjust Mode the output voltage is determined by an external resistor divider from VOUT to BSEN. When BSEN is connected in this fashion,  $V_{VOUT}$  (during Constant Voltage (CV) charging) will be controlled such that the voltage at the BSEN pin ( $V_{BSEN}$ ) is the reference voltage  $V_{BSEN-ADJ}$ .

The output voltage can be set to any voltage desired by an appropriate choice of divider network resistors, within the following limits. When the SC804 is programmed for adjust mode,  $V_{VOUT}$  is required to be 150mV less than  $V_{VCC}$  and  $V_{VOUT}$  is required to be 400mV greater than  $V_{BSEN}$ .

$V_{VOUT}$  within 150mV of  $V_{BSEN}$  guarantees normal mode operation. This implies that, for BSEN used as a Kelvin sense of battery voltage, the product of the fast charge



**POWER MANAGEMENT**
**Applications Information (Cont.)**

current and the charge path resistance from VOUT to the Kelvin sense point should not exceed 150mV to ensure normal mode operation.

The SC804 Adjust Mode schematic is shown in Figures 3A and 3B. Referring to these schematics, the equation for setting the output voltage is:

$$V_{OUT} = V_{BSEN-ADJ\_Typ} \times \left( 1 + \frac{R11}{R12} \right)$$

The capacitor C3 across R8 in the feedback network introduces zero-pole frequency compensation for stability. Place the zero according to the following equation to ensure stability:

$$R11 \times C3 = \frac{1}{2\pi \times 100kHz}$$

**NOTE:** When using Adjust Mode to program a CV regulation voltage greater than  $V_{CV}$ , care must be taken when CC charging with a charging adapter operating in current limit. Adapter current-limited operation occurs when the adapter current limit is less than the programmed SC804 fast charge current, such that the adapter voltage is pulled down to  $V_{VOUT}$  plus the SC804 dropout voltage. A low adapter current limit multiplied by the low minimum path resistance of the main pass transistor and current sense resistor (as low as 290mΩ total at extremely low temperature) can result in a voltage drop from VCC to VOUT of less than 150mV if the Adjust Mode CV regulation voltage is programmed above  $V_{CV} + 50mV$ . If  $V_{VCC} - V_{VOUT} < 150mV$ , Adjust Mode may not operate correctly. Adjust Mode will operate correctly whenever the programmed VOUT CV voltage is less than  $V_{CV} + 50mV$ , regardless of the adapter current limit, because the regulated minimum dropout voltage is always greater than 150mV in this case. It will also operate correctly with an adapter current limit greater than 550 mA, regardless of the programmed output voltage, because the I-R dropout voltage will exceed 150mV at even the lowest specified operating temperature. Normal mode (that is, not Adjust Mode) has a regulated minimum dropout voltage of approximately 200mV, which is constant for any  $V_{VOUT}$ , and so operates correctly for any adapter current limit.

**Over current and Max Temperature Protection**

Over current protection is inherent in all modes of

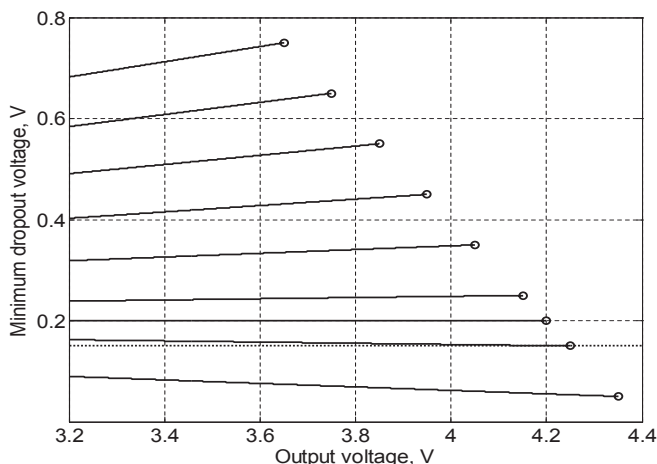

**Figure 4 - Adjust Mode Minimum Dropout Voltage**

The actual dropout voltage is the greater of the Minimum Dropout Voltage at various programmed  $V_{CV}$  and instantaneous VOUT voltages (shown here, with several programmed  $V_{CV}$  voltages indicated in the figure by 'o'), and the IR drop due to the product of IOU and  $R_{DS-ON}$  (not shown here). Adjust mode operation is ensured for any IOU current at programmed  $V_{CV}$  voltages up to approximately 4.25V.

operation. When the device is in charge mode the output is current-limited to either the pre-charge current limit value or the fast charge current limit value depending on the voltage at the output. Max die temperature protection is also included. This feature allows the SC804 to operate with maximum power dissipation by disabling the output current when the die temperature reaches the maximum operating temperature. The result is that the SC804 will operate as a pulse charger in extreme power dissipation applications, delivering the maximum allowable output current while regulating the internal die temperature to a safe level.

**Indicator Flags**

There are four indicator outputs/LED drivers on the SC804: CPB (Charger Present), CHRGB (Charge Active), OVPB (Over Voltage Fault), and FLT B (Fault). These outputs are all active-low, open drain NMOS drivers capable of sinking up to 10mA. The following table defines each indicator's output state.

The CPB output can be used as a VCC-present indicator. Regardless of the state of NTC, the CPB output reflects the VCC voltage. When  $V_{VCC}$  is between the UVLO and OVP thresholds the CPB output is low. If  $V_{VCC}$  is outside these limits this output is high impedance.

**POWER MANAGEMENT**

**Applications Information (Cont.)**

FLAG	ON	OFF
CPB	$UVLO < VCC < OVP$	Input out of range
CHRGB	$IOUT > ITERM$	$IOUT < ITERM$
OVPB	$VCC > OVP$	$VCC < OVP$
FLTB	$VCC > OVP$ $VCC < UVLO$ NTC Temp Fault Pre-Charge Time-out (OT ( $T_j > 150^{\circ}C$ ))	Normal Operation or NTC Disable

The OVPB signal is an active-low output that signals when the input voltage exceeds the OVP threshold. When the voltage on VCC is less than the OVP threshold voltage this output is high impedance. The FLTB output is activated when the SC804 experiences a fault condition. This output can be used to notify the system controller of a fault condition when connected to an interrupt input, or it can be used like CPB and CHRGB to drive an indicator LED. The five fault modes signaled by FLTB are: input over-voltage, input under-voltage, NTC temperature out of range, max die temperature (OT), and pre-charge time-out. When any of these conditions occurs the FLTB output goes low; otherwise it remains high impedance.

The CHRGB output indicates the charging status. When the output current is greater than ITERM, CHRGB is low. CHRGB is high impedance when IOUT is less than ITERM. The CHRGB output is latched during the charge cycle when the output current is less than ITERM. This latch is reset when the battery enters a recharge cycle, or if NTC or VCC are toggled.

**Capacitor Selection**

Low cost, low ESR ceramic capacitors such as the X5R and X7R dielectric material types are recommended for use with the SC804. The output capacitance range is  $1\mu F$  to  $4.7\mu F$ . The input capacitor is typically between  $0.1\mu F$  to  $1\mu F$ , but Charge Mode Timing Diagram larger values will not degrade performance.

**Charge Mode Timing Diagram**

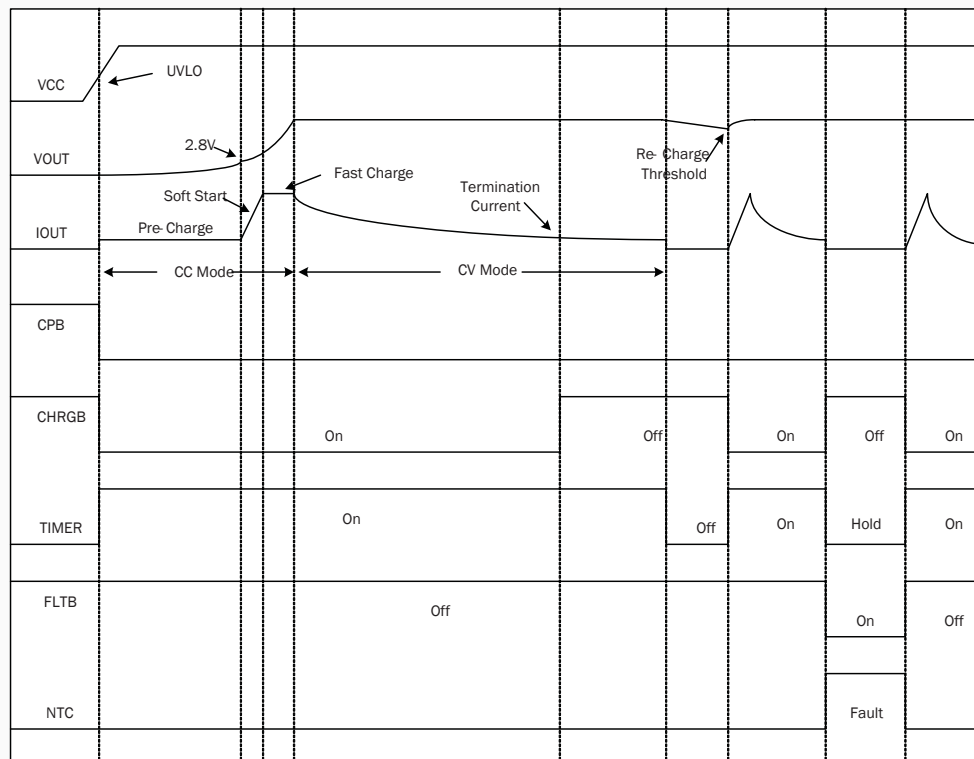

**Figure 5 - Charge Mode Timing**

POWER MANAGEMENT

State Diagram

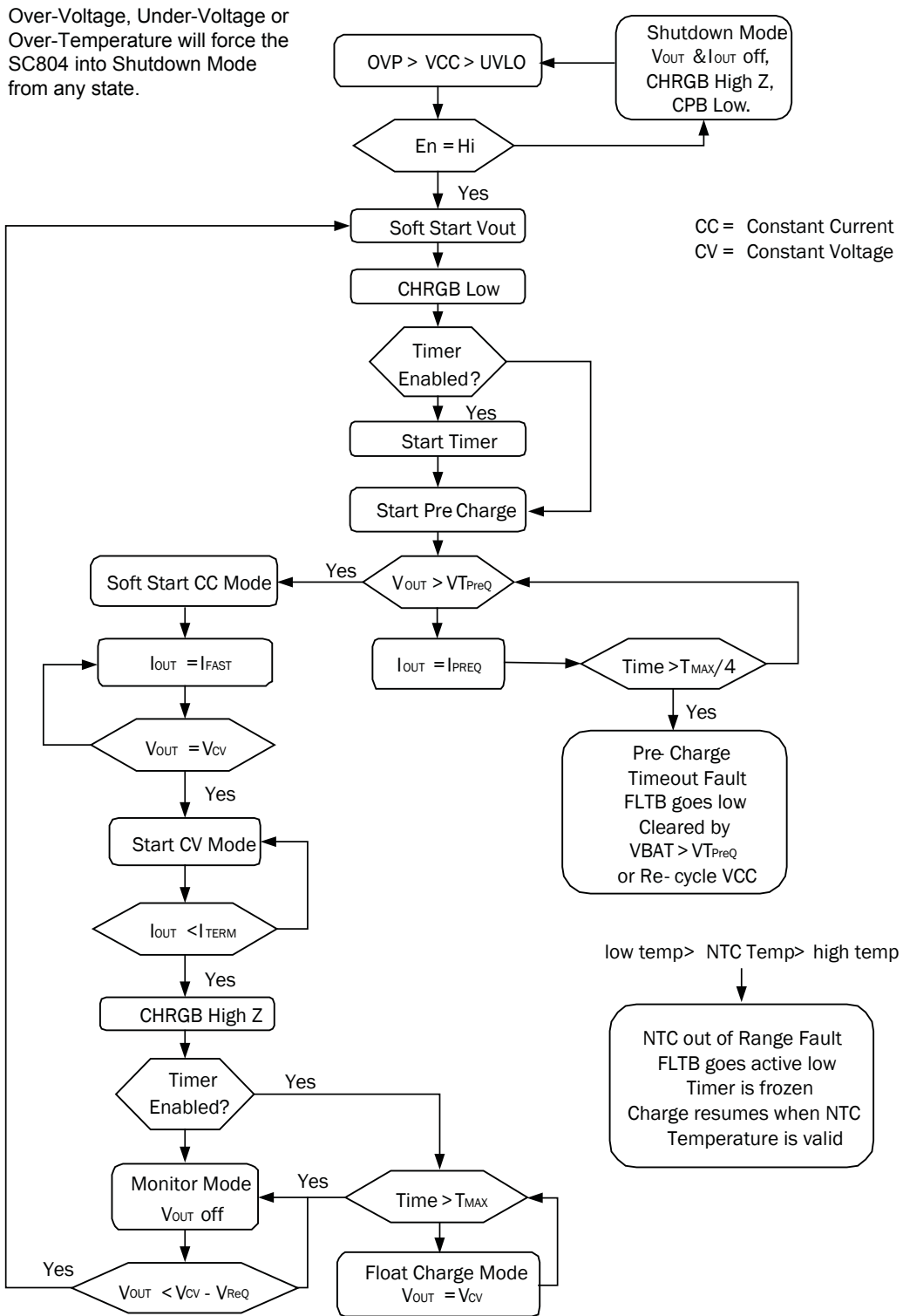

**POWER MANAGEMENT**

**Typical Charge Cycle**

**Typical Charge Cycle**

Evaluation Board configured for internal timer, 1.5V on IPRGM = 810mA, 1.5V on ITERM = 300mA, VCC = 5.0V, Li-Ion battery capacity = 1000mAh. A 70mA battery load was applied after initial charge timeout, and removed during the recharge cycle prior to termination.

(a) Constant Current (CC) Charging (Fast Charge); (b) Constant Voltage (CV) Charging; (c) Termination; (d) Float Charging; (e) Timer Expiration; (f) Slow Battery Discharge; (g) Recharge; (h) Termination.

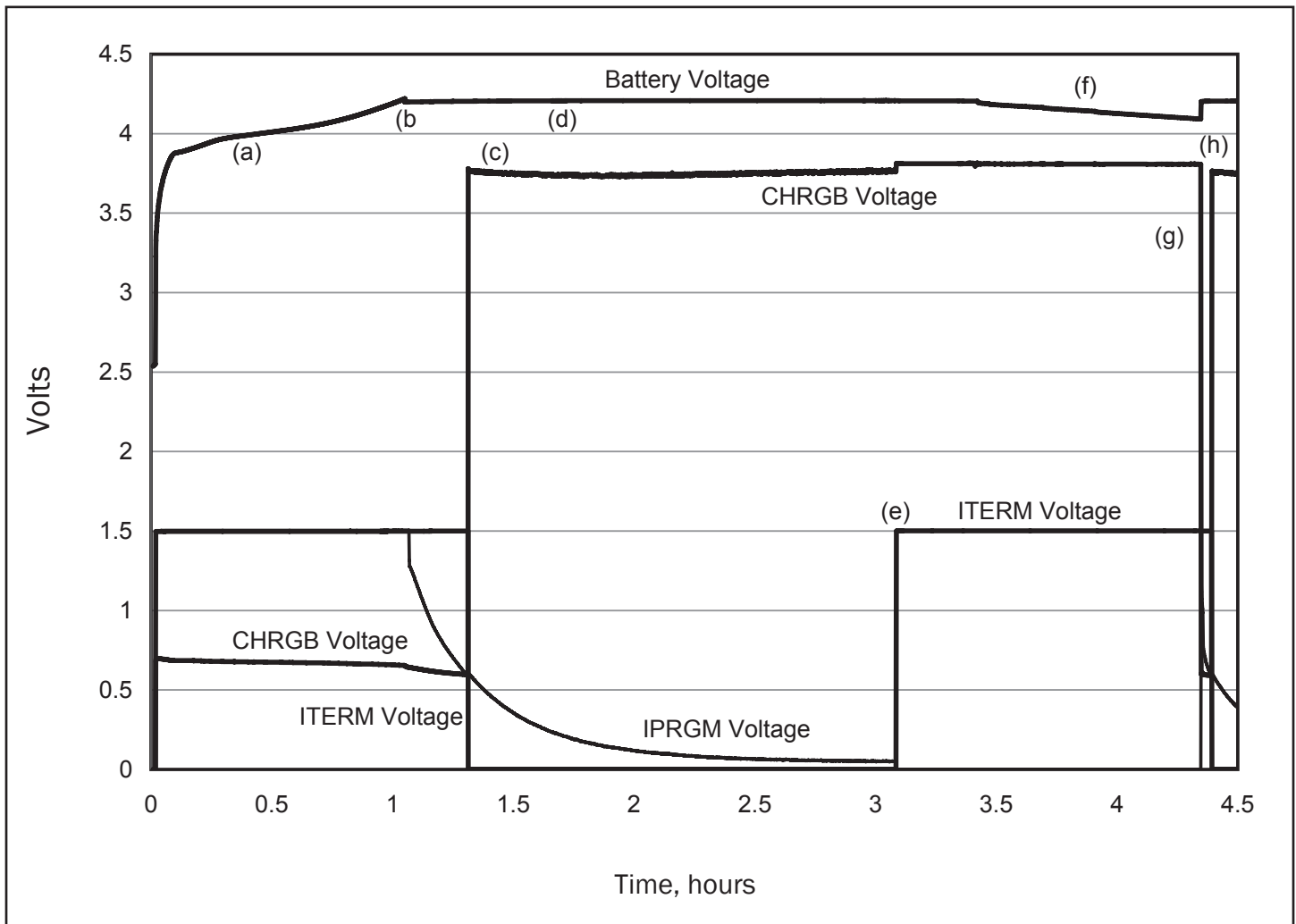



POWER MANAGEMENT

Typical Characteristics

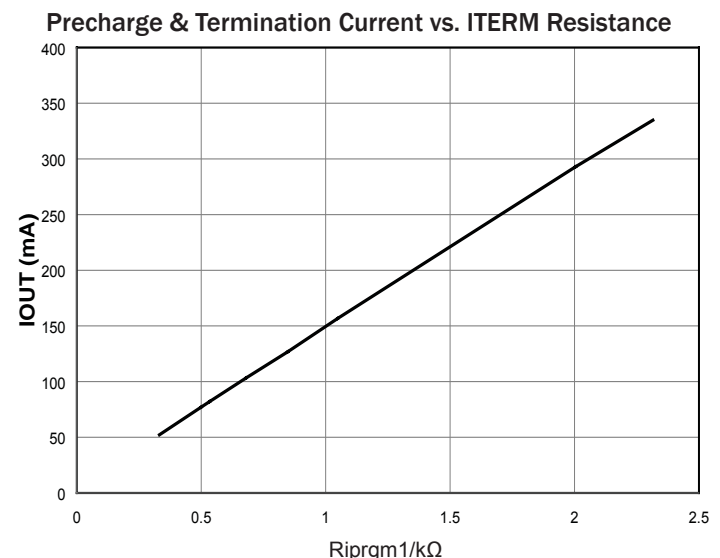
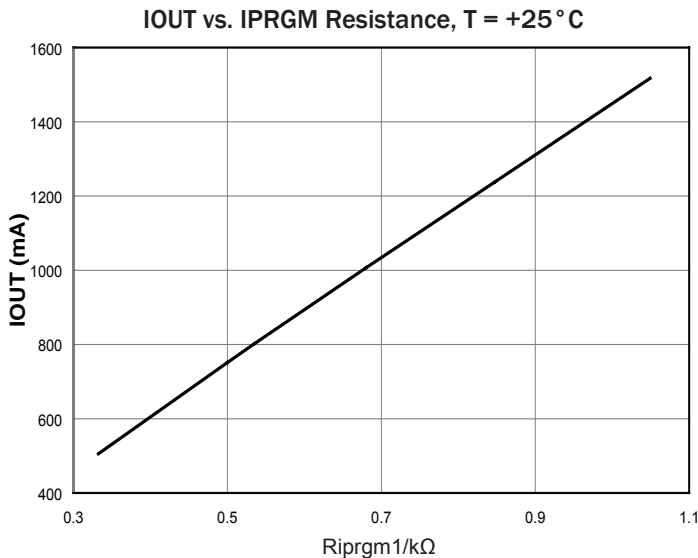
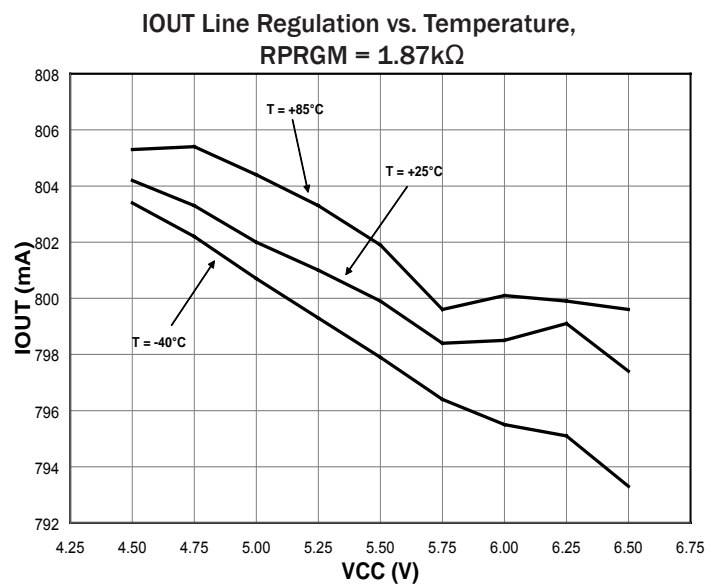
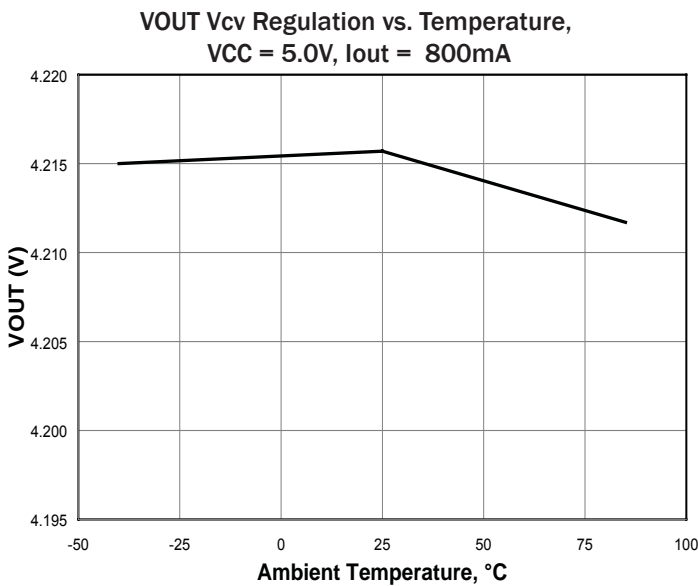
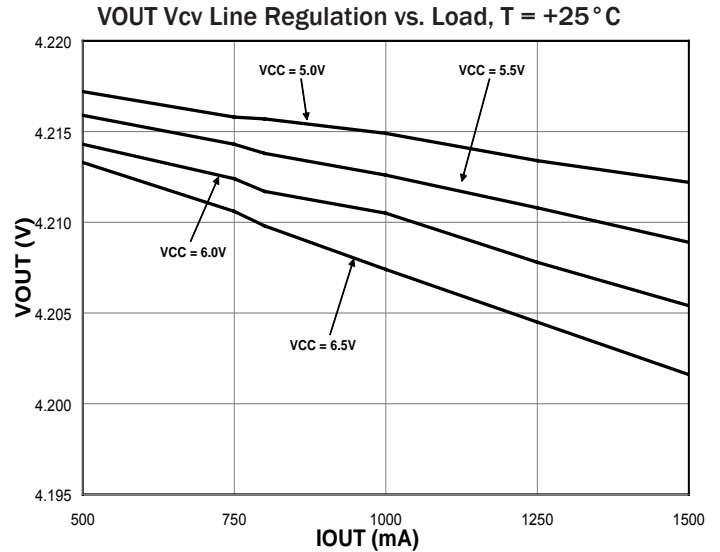
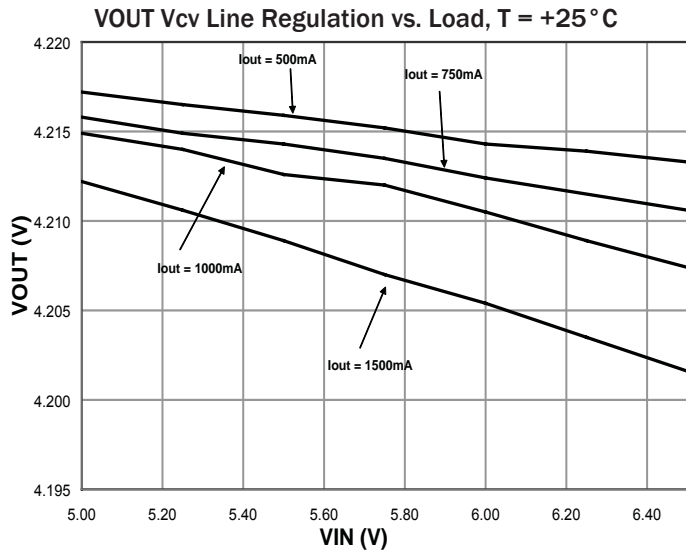

POWER MANAGEMENT

Typical Characteristics (Cont.)

Dropout Voltage vs. IO<sub>UT</sub>

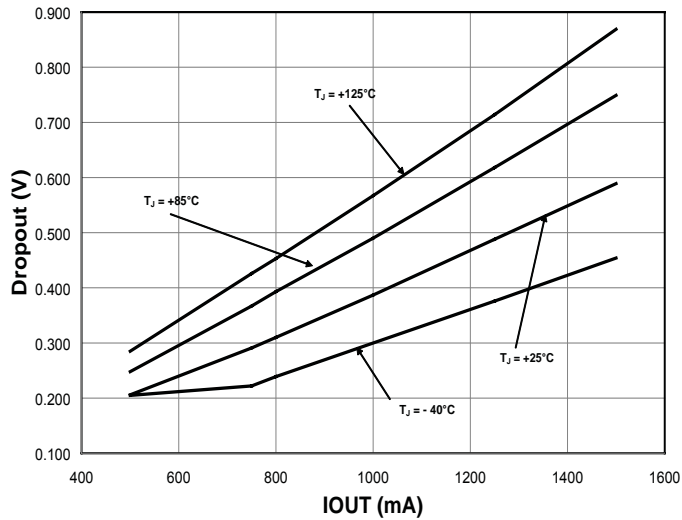

R<sub>ds-on</sub> vs. IO<sub>UT</sub>

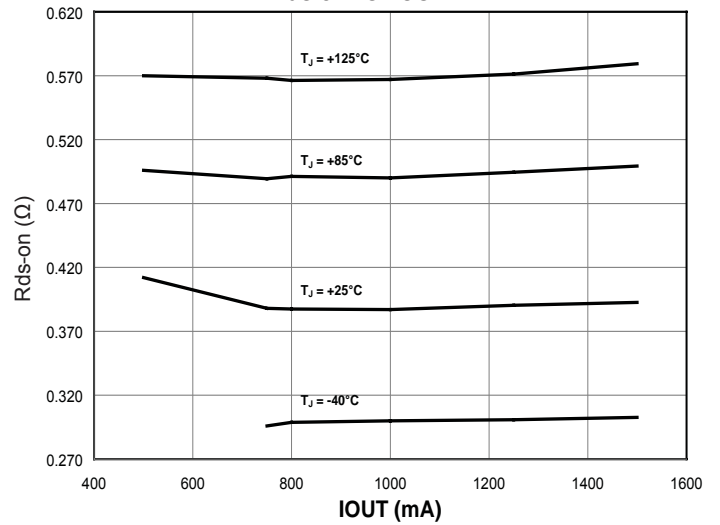

AFC Operation, R<sub>PRGM</sub> = 1.78kΩ

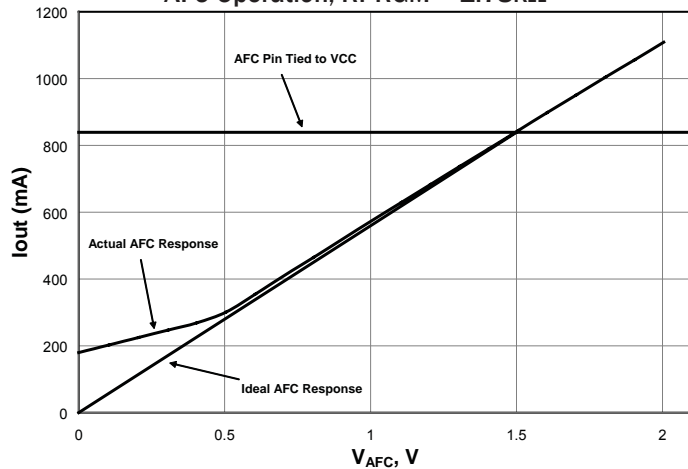

POWER MANAGEMENT

Evaluation Board Schematic

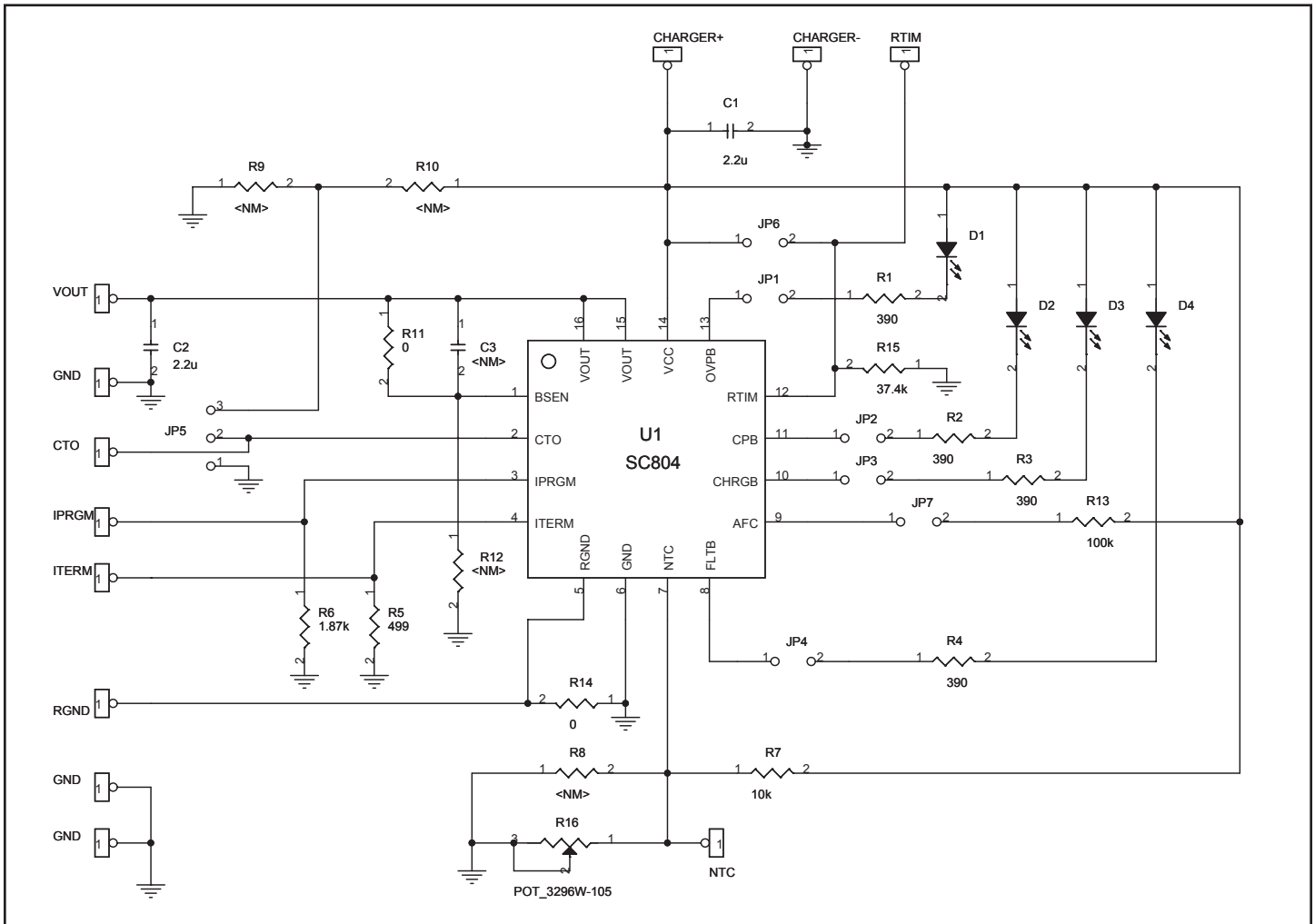

Evaluation Board Gerber Plots

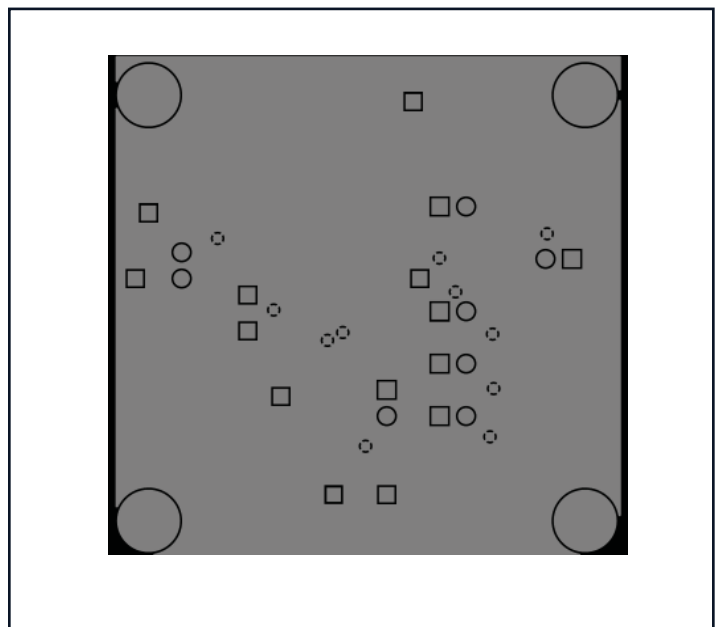
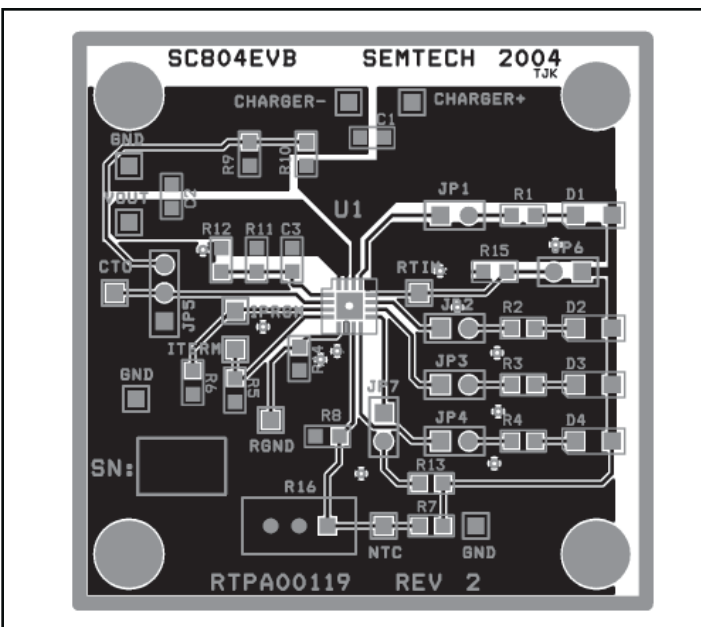

POWER MANAGEMENT

Outline Drawing - MLPQ-16

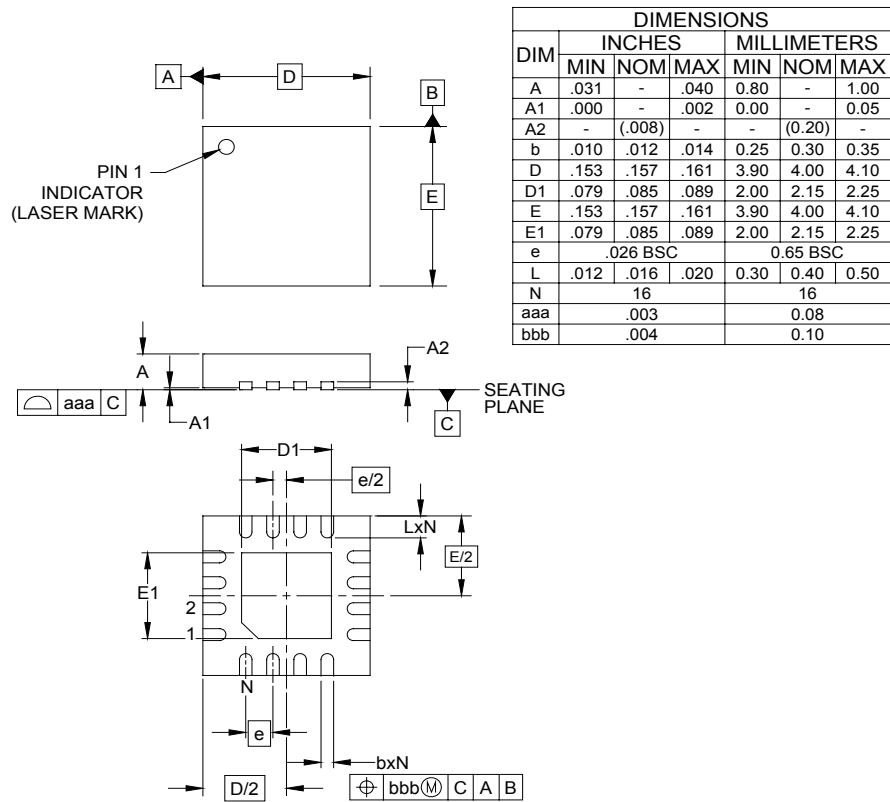

- NOTES:
1. CONTROLLING DIMENSIONS ARE IN MILLIMETERS (ANGLES IN DEGREES).
  2. COPLANARITY APPLIES TO THE EXPOSED PAD AS WELL AS THE TERMINALS.

Marking Information

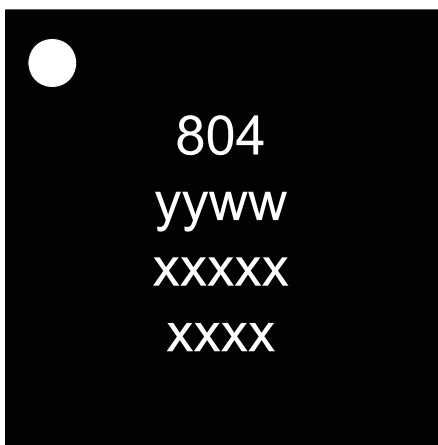

yyww = Date Code  
 Example (0552)  
 xxxxx xxxx = Semtech Lot Number  
 Example: (E9010 01-1)

**POWER MANAGEMENT**

**Land Pattern - MLPQ-16**

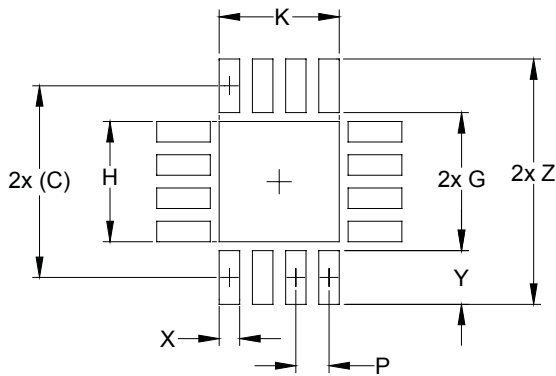

DIMENSIONS		
DIM	INCHES	MILLIMETERS
C	(.156)	(3.95)
G	.122	3.10
H	.091	2.30
K	.091	2.30
P	.026	0.65
X	.016	0.40
Y	.033	0.85
Z	.189	4.80

NOTES:

1. THIS LAND PATTERN IS FOR REFERENCE PURPOSES ONLY. CONSULT YOUR MANUFACTURING GROUP TO ENSURE YOUR COMPANY'S MANUFACTURING GUIDELINES ARE MET.

**Contact Information**

Semtech Corporation  
 Power Management Products Division  
 200 Flynn Road, Camarillo, CA 93012  
 Phone: (805) 498-2111 FAX (805)498-3804