



# PJ4812

## 25V Dual N-Channel Enhancement Mode MOSFET

### FEATURES

- $R_{DS(ON)}$ ,  $V_{GS}$  @ 10V,  $I_{DS}$  @ 5.8A = 15m $\Omega$
- $R_{DS(ON)}$ ,  $V_{GS}$  @ 4.5V,  $I_{DS}$  @ 4.7A = 24m $\Omega$
- Advanced Trench Process Technology
- High Density Cell Design For Ultra Low On-Resistance
- Specially Designed for DC/DC Converters
- Fully Characterized Avalanche Voltage and Current
- Pb free product : 99% Sn above can meet RoHS environment substance directive request

### MECHANICAL DATA

- Case: SOIC-08 Package
- Terminals : Solderable per MIL-STD-750, Method 2026
- Marking : 4812

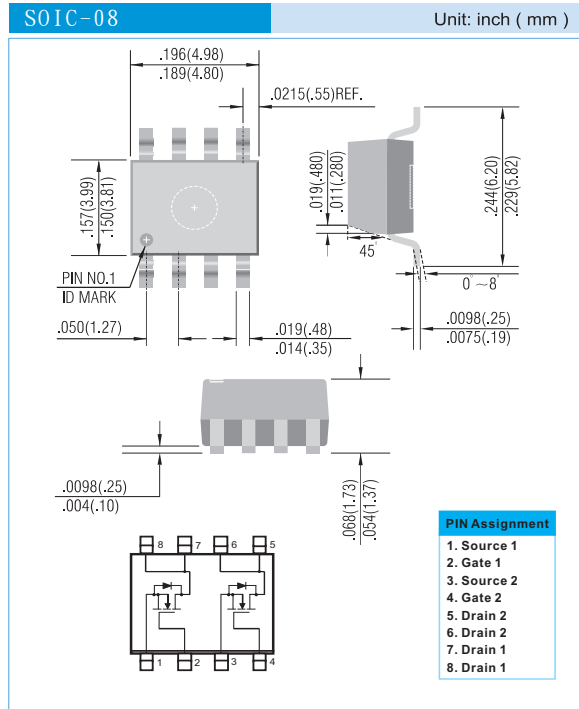

### Maximum RATINGS and Thermal Characteristics ( $T_A=25^\circ\text{C}$ unless otherwise noted)

PARAMETER	Symbol	Limit	Units
Drain-Source Voltage	$V_{DS}$	25	V
Gate-Source Voltage	$V_{GS}$	$\pm 20$	V
Continuous Drain Current	$I_D$	5.8	A
Pulsed Drain Current <sup>1)</sup>	$I_{DM}$	24	A
Maximum Power Dissipation	$P_D$	$T_A=25^\circ\text{C}$ 2.0 $T_A=75^\circ\text{C}$ 1.2	W
Operating Junction and Storage Temperature Range	$T_J, T_{STG}$	-55 to + 150	$^\circ\text{C}$
Avalanche Energy with Single Pulse $I_D=23\text{A}, V_{DD}=25\text{V}, L=0.5\text{mH}$	$E_{AS}$	130	mJ
Junction-to Ambient Thermal Resistance(PCB mounted) <sup>2)</sup>	$R_{\theta JA}$	62.5	$^\circ\text{C/W}$

- Note: 1. Maximum DC current limited by the package  
2. Surface mounted on FR4 board,  $t \leq 10$  sec

**PAN JIT RESERVES THE RIGHT TO IMPROVE PRODUCT DESIGN, FUNCTIONS AND RELIABILITY WITHOUT NOTICE**



# PJ4812

## ELECTRICAL CHARACTERISTICS

Parameter	Symbol	Test Condition	Min.	Typ.	Max.	Units
<b>Static</b>						
Drain-Source Breakdown Voltage	$BV_{DSS}$	$V_{GS}=0V, I_D=250\mu A$	25	-	-	V
Gate Threshold Voltage	$V_{GS(th)}$	$V_{DS}=V_{GS}, I_D=250\mu A$	1	-	3	V
Drain-Source On-State Resistance	$R_{DS(on)}$	$V_{GS}=4.5V, I_D=4.7A$	-	19.8	24.0	mΩ
Drain-Source On-State Resistance	$R_{DS(on)}$	$V_{GS}=10V, I_D=5.8A$	-	12.0	15.0	
Zero Gate Voltage Drain Current	$I_{DSS}$	$V_{DS}=25V, V_{GS}=0V$	-	-	1	μA
Gate Body Leakage	$I_{GSS}$	$V_{GS}=\pm 20V, V_{DS}=0V$	-	-	±100	nA
Forward Transconductance	$g_{fs}$	$V_{DS}=10V, I_D=5.8A$	20	-	-	S
<b>Dynamic</b>						
Total Gate Charge	$Q_g$	$V_{DS}=15V, I_D=5.8A, V_{GS}=5V$	-	15.8	-	nC
			-	26.8	-	
Gate-Source Charge	$Q_{gs}$	$V_{DS}=15V, I_D=5.8A, V_{GS}=10V$	-	5.0	-	
Gate-Drain Charge	$Q_{gd}$		-	5.5	-	
Turn-On Delay Time	$T_{d(on)}$	$V_{DD}=15V, R_L=15\Omega, I_D=1A, V_{GEN}=10V, R_G=3.6\Omega$	-	12	14	ns
Turn-On Rise Time	$t_{rr}$		-	10	12.5	
Turn-Off Delay Time	$t_{d(off)}$		-	32	37.5	
Turn-Off Fall Time	$t_f$		-	6.5	8	
Input Capacitance	$C_{iss}$	$V_{DS}=15V, V_{GS}=0V, f=1.0MHz$	-	1450	-	pF
Output Capacitance	$C_{oss}$		-	260	-	
Reverse Transfer Capacitance	$C_{rss}$		-	150	-	
<b>Source-Drain Diode</b>						
Max. Diode Forward Current	$I_s$	-	-	-	1.7	A
Diode Forward Voltage	$V_{SD}$	$I_s=1.7A, V_{GS}=0V$	-	0.73	1.2	V

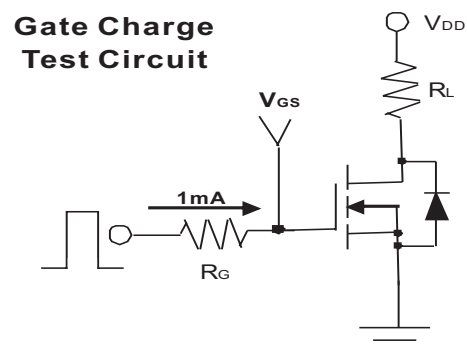
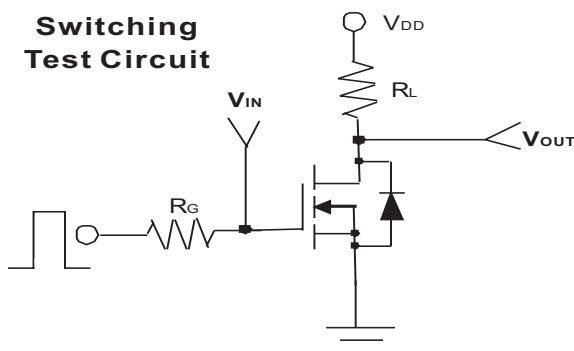



# PJ4812

Typical Characteristics Curves ( $T_J=25^\circ\text{C}$ , unless otherwise noted)

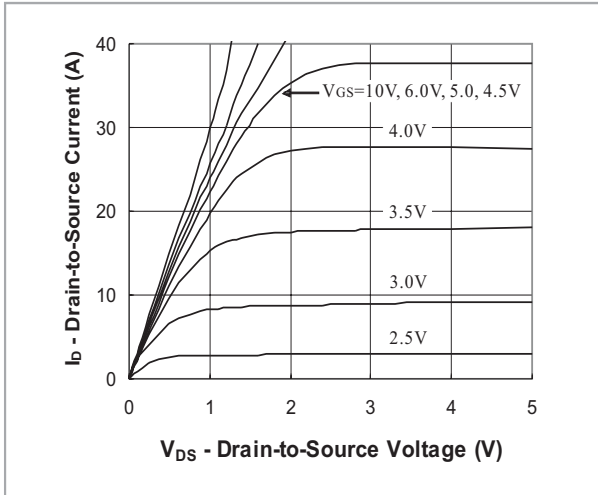

FIG.1- Output Characteristic

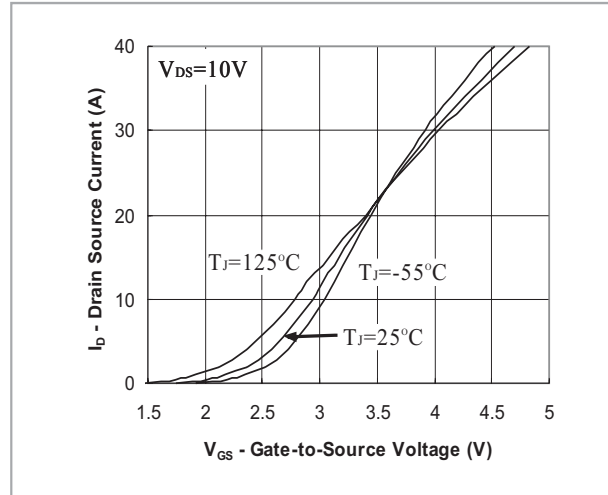

FIG.2- Transfer Characteristic

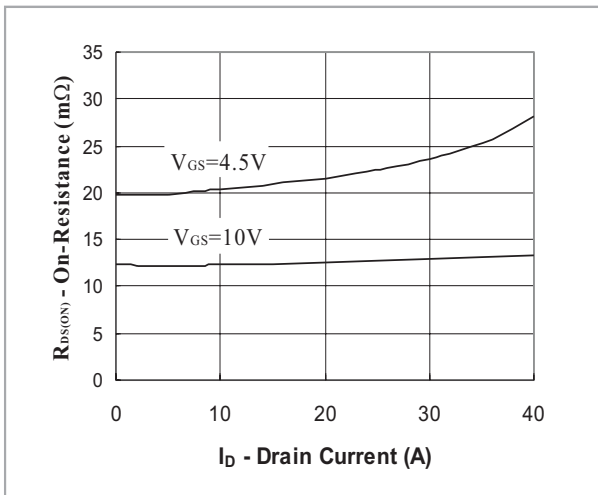

FIG.3- On Resistance vs Drain Current

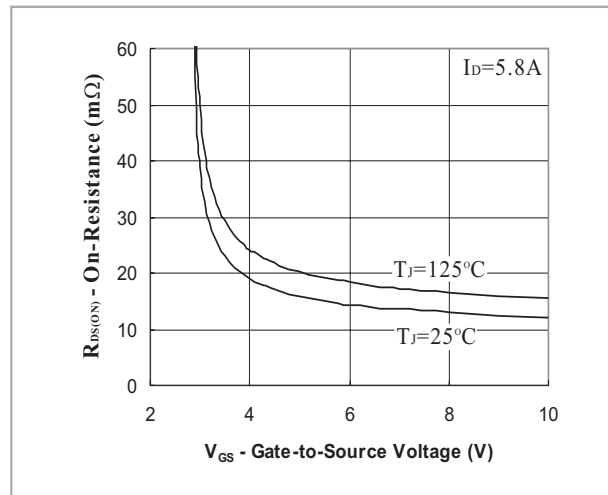

FIG.4- On Resistance vs Gate to Source Voltage

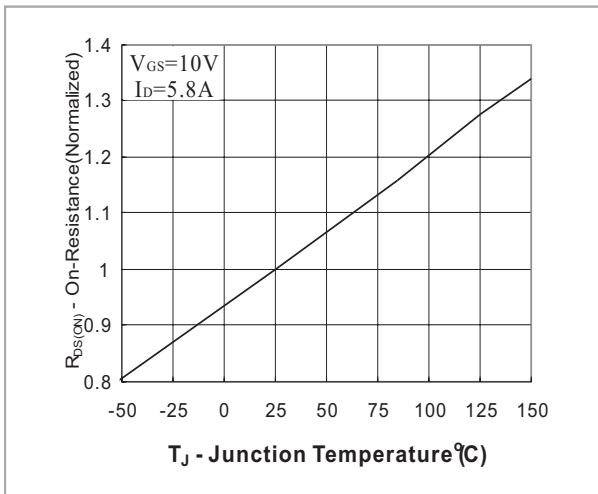

FIG.5- On Resistance vs Junction Temperature

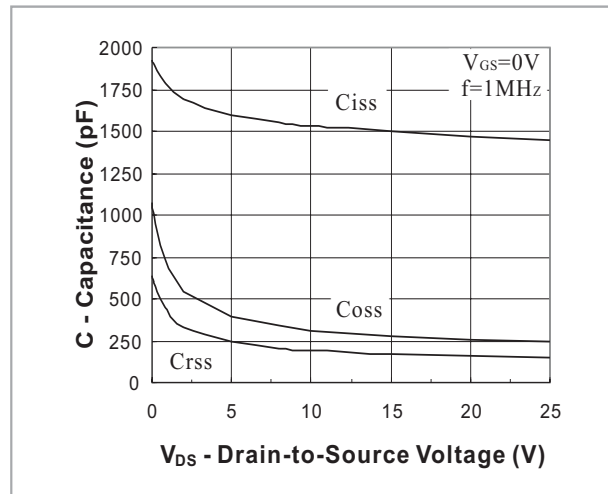

FIG.6- Capacitance



# PJ4812

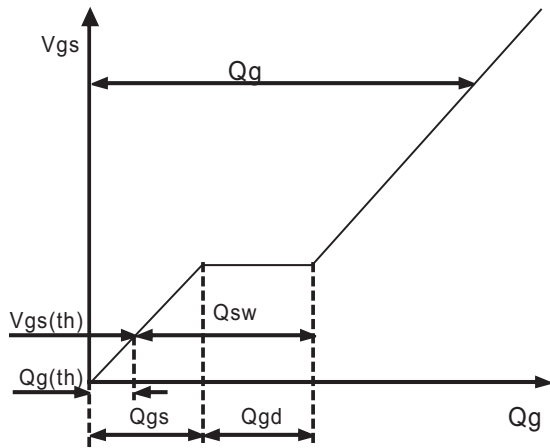

Fig. 7 - Gate Charge Waveform

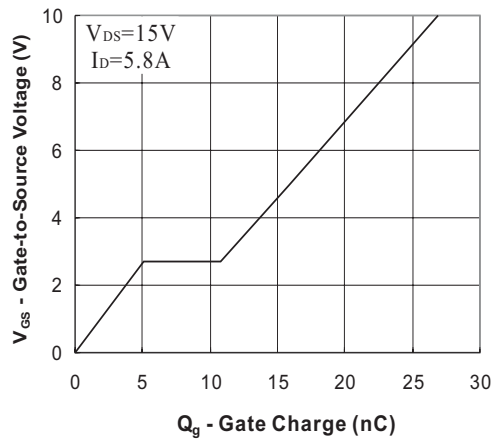

Fig. 8 - Gate Charge

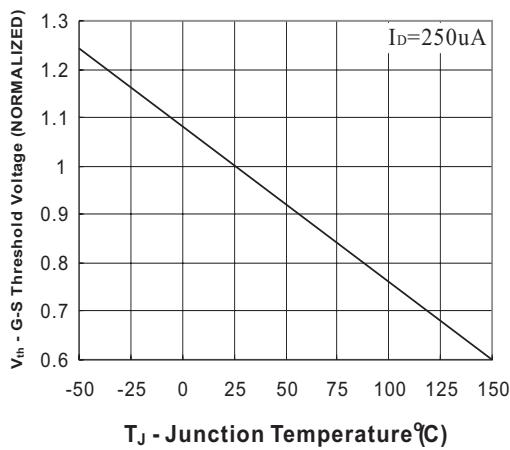

Fig. 9 - Threshold Voltage vs Temperature

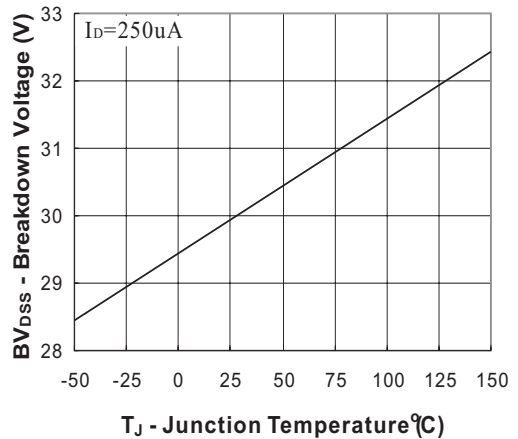

Fig. 10 - Breakdown Voltage vs Junction Temperature

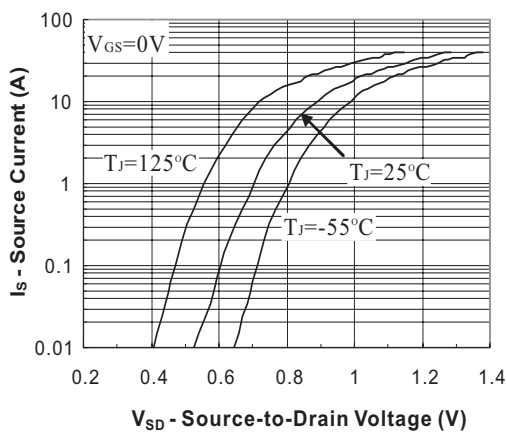
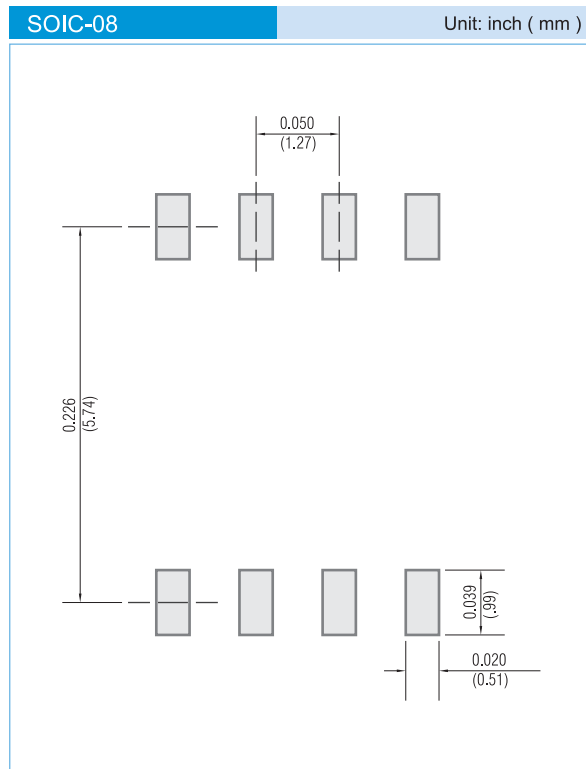

Fig. 11 - Source-Drain Diode Forward Voltage



# PJ4812

## MOUNTING PAD LAYOUT



## ORDER INFORMATION

- Packing information  
T/R - 3K per 13" plastic Reel

## LEGAL STATEMENT

### Copyright PanJit International, Inc 2006

The information presented in this document is believed to be accurate and reliable. The specifications and information herein are subject to change without notice. Pan Jit makes no warranty, representation or guarantee regarding the suitability of its products for any particular purpose. Pan Jit products are not authorized for use in life support devices or systems. Pan Jit does not convey any license under its patent rights or rights of others.