



A. HE83121 Introduction

HE83121 is a member of 8-bit Micro-controller series that is developed by King Billion. This IC built-in 320-dot LCD driver and has one OP comparator. The built-in OP comparator can be used with (light、voice、temperature、humidity) sensor etc. The 7-bit current-type D/A converter and PWM device provide the complete speech output mechanism. The 128K ROM Size can storage around 40 second's speech. This IC is applicable to the small/medium systems such as LCD Games and Perpetual Calendar etc. This IC is very easy to learn and use. Most of instructions take only 3 oscillator clocks (machine cycles). As a result this IC is suitable for the applications that require higher performance system.

B. HE83121 Features

- Operation Voltage : 2.2V – 5.5V
- System Clock : DC ~ 8MHz @ 5.0V
DC ~ 4MHz @ 2.2V
- Internal ROM : 128K Bytes(64K Program ROM+64K Data ROM)
- Internal RAM : 256 Bytes
- Dual Clock System : Normal (Fast) clock : 32.768K ~ 8MHz
Slow clock : 32.768KHz
- Operation Mode : DUAL、FAST、SLOW、IDLE、SLEEP Mode.
- With WDT (WATCH DOG TIMER) to prevent deadlock condition.
- 12-bit Bi-directional I/O port. Mask Option can select PUSH-PULL or OPEN DRAIN output mode for each I/O pin.
- One built-in OP comparator.
- 320 dots LCD driver (A、B TYPE selectable).
- One 7-bit current-type DAC output.
- PWM device.
- Two external interrupts and two internal timers interrupts.



- Two 16-bit timers.
- Instruction set : 32 instructions, 4 addressing mode. 8-bit DATA POINTER for RAM and 17-bit TABLE POINTER for ROM.

C.HE83121 Application

- LCD Game 、 Perpetual Calendar System etc..
- Light, voice, temperature, humidity-controlled system's speech. Applicable to the LCD application.

D. Pin Assignment

Pin #	Pin Name	I/O	Function	Description
68 67	FXI, FXO	B, O	External fast clock pin. Connecting to crystal or RC to generate 32.768 kHz ~ 8MHz system clock.	Mask Option settings : MO_FCK/SCKN=00 : Slow Clock only 01 : Illegal 10 : Dual Clock 11 : Fast Clock only MO_FOSCE=0 : Internal fast oscillation 1 : External fast oscillation MO_FXTAL=0 : R,C oscillation for Fast Clock 1 : Crystal oscillation for Fast Clock MO_SXTAL=0 : R,C oscillation for 32.768K Clock 1 : Crystal oscillation for 32.768K
71 70	SXI, SXO	I, O	External slow clock pin. Connecting with 32.768 Hz OSC to generate the stable frequency for Slow Clock Mode and Timer clock source.	Clock ◦ Program the value of OP1 and OP2 to change the operating modes (Normal, Slow, Idle and Sleep). In Dual Clock mode , the system runs in Fast Clock, only the LCD and timer I use the 32.768K clock source ◦
66	RSTP_N	I	System reset signal	Pull this pin to low level to reset the system. Besides, select the Mask Option (MQ_PORE=1) to enable the HE83121 internal Power-on Reset function. In addition, the MO_WDTE is used for Watch Timer setting :



				MO_WDTE=0 : Disable Watch Dog Timer =1 : Enable Watch Dog Timer
69	TSTP_P	I	Test Pin	Pull the pin to high level to enter into testing mode.
81.. 83 1	PRTC[3:0]	B	Port C bi-directional I/O Pin (4Pins)	Mask Option MO_CPP[3:0] to preset the output type : MO_CPP=1 : Push-pull output; =0 : Open-drain output When assigned the port to input pin, send a '1' and read the result to get the input value
73.. 80	PRTD[7:0]	B	Port D bi-directional I/O pin (8 pins). PRTD[7:2] is also a Wake-up pin and PRTD[7:6] is used for interrupt input pin.	Mask Option MO_DPP[7:0] to preset the output type : MO_DPP=1 : Push-pull output; =0 : Open-drain output When assigned the port to input pin, send a '1' and read the result to get the input value
44.. 51	COM[7:0]	O	LCD COMmon Output	Data filled from D8H, please refer the LCD RAM Map
4..43	SEG[39:0]	O	LCD SEGment Output	
53	LC2	B	Charge Pump Switch 1	Please refer the application circuit
52	LC1	B	Charge Pump Switch 2	
55	LV3	B	Charge Pump V3	Please refer the application circuit
54	LV1	B	Charge Pump V1	
56.. 59	LR[4..1]	B	LCD Resister level 4 ~ 0	Please refer the application circuit
60	LVG	I	LCD Virtual Ground	Please refer the application circuit
2	PWMP	O	PWM +ve output pin can directly drive Speaker or Buzzer for sound output.	Set the Bit2 for VOC register (PWM =1) to turn on the PWM
3	PWMN	O	PWM -ve output pin can directly drive Speaker or Buzzer for sound output.	Set the Bit2 for VOC register (PWM =1) to turn on the PWM
62	VO	O	D/A voice output	Set the bit1 (DA=1) of VOC register to turn on VO
63	OPIN	I	OPAMP Inverting pin	Set the bit1 (OP=1) register to turn on OP



64	OPIP	I	OPAMP Non-Inverting pin	Individual Op comparator
65	OPO	O	OPAMP Output pin	
72	VDD	P	Positive Power Input	
61	GND	P	Power Ground Input	

E.LCD RAM Map

	SEG [7:0]	SEG [15:8]	SEG [23:16]	SEG [31:24]	SEG [39:32]
COM0	D8H	E0H	E8H	F0H	F8H
COM1	D9H	E1H	E9H	F1H	F9H
COM2	DAH	E2H	EAH	F2H	FAH
COM3	DBH	E3H	EBH	F3H	FBH
COM4	DCH	E4H	ECH	F4H	FCH
COM5	DDH	E5H	EDH	F5H	FDH
COM6	DEH	E6H	EEH	F6H	FEH
COM7	DFH	E7H	EFH	F7H	FFH



G. Bonding Pad Location

PIN Number	PIN Name	X Coordinate	Y Coordinate	PIN Number	PIN Name	X Coordinate	Y Coordinate
1	PRTC[0]	X= -1339.50	Y= 905.20	43	SEG[0]	X= 1339.90	Y= -1302.80
2	PWMP	X= -1339.50	Y= 789.80	44	COM[7]	X= 1339.90	Y= -1187.20
3	PWMN	X= -1339.50	Y= 674.20	45	COM[6]	X= 1339.90	Y= -1071.80
4	SEG[39]	X= -1339.50	Y= 558.80	46	COM[5]	X= 1339.90	Y= -956.20
5	SEG[38]	X= -1339.50	Y= 443.20	47	COM[4]	X= 1339.90	Y= -840.80
6	SEG[37]	X= -1339.50	Y= 327.80	48	COM[3]	X= 1339.90	Y= -725.20
7	SEG[36]	X= -1339.50	Y= 212.20	49	COM[2]	X= 1339.90	Y= -609.80
8	SEG[35]	X= -1339.50	Y= 96.80	50	COM[1]	X= 1339.90	Y= -494.20
9	SEG[34]	X= -1339.50	Y= -18.80	51	COM[0]	X= 1339.90	Y= -378.80
10	SEG[33]	X= -1339.50	Y= -134.20	52	LC1	X= 1339.90	Y= -263.20
11	SEG[32]	X= -1339.50	Y= -249.80	53	LC2	X= 1339.90	Y= -147.80
12	SEG[31]	X= -1339.50	Y= -365.20	54	LV1	X= 1339.90	Y= -32.20
13	SEG[30]	X= -1339.50	Y= -480.80	55	LV3	X= 1339.90	Y= 83.20
14	SEG[29]	X= -1339.50	Y= -596.20	56	LR4	X= 1339.90	Y= 198.80
15	SEG[28]	X= -1339.50	Y= -711.80	57	LR3	X= 1339.90	Y= 314.20
16	SEG[27]	X= -1339.50	Y= -827.20	58	LR2	X= 1339.90	Y= 429.80
17	SEG[26]	X= -1339.50	Y= -942.80	59	LR1	X= 1339.90	Y= 545.20
18	SEG[25]	X= -1339.50	Y= -1058.20	60	LVG	X= 1339.90	Y= 660.80
19	SEG[24]	X= -1339.50	Y= -1173.80	61	GND	X= 1339.90	Y= 776.20
20	SEG[23]	X= -1339.50	Y= -1289.20	62	VO	X= 1339.90	Y= 891.80
21	SEG[22]	X= -1339.50	Y= -1404.80	63	OPIN	X= 1339.90	Y= 1007.20
22	SEG[21]	X= -1075.00	Y= -1641.00	64	OPIP	X= 1121.00	Y= 1639.60
23	SEG[20]	X= -959.50	Y= -1641.00	65	OPO	X= 1005.50	Y= 1639.60
24	SEG[19]	X= -844.00	Y= -1641.00	66	RSTP_N	X= 890.00	Y= 1639.60



25	SEG[18]	X= -728.50	Y= -1641.00	67	FXO	X= 774.50	Y= 1639.60
26	SEG[17]	X= -613.00	Y= -1641.00	68	FXT	X= 659.00	Y= 1639.60
27	SEG[16]	X= -497.60	Y= -1641.00	69	TSTP_P	X= 543.50	Y= 1639.60
28	SEG[15]	X= -382.10	Y= -1641.00	70	SXO	X= 428.10	Y= 1639.60
29	SEG[14]	X= -266.60	Y= -1641.00	71	SXI	X= 312.60	Y= 1639.60
30	SEG[13]	X= -151.10	Y= -1641.00	72	VDD	X= 197.10	Y= 1639.60
31	SEG[12]	X= -35.50	Y= -1641.00	73	PRTD[7]	X= 81.50	Y= 1639.60
32	SEG[11]	X= 80.00	Y= -1641.00	74	PRTD[6]	X= -34.00	Y= 1639.60
33	SEG[10]	X= 195.40	Y= -1641.00	75	PRTD[5]	X= -149.40	Y= 1639.60
34	SEG[9]	X= 310.90	Y= -1641.00	76	PRTD[4]	X= -264.90	Y= 1639.60
35	SEG[8]	X= 426.40	Y= -1641.00	77	PRTD[3]	X= -380.40	Y= 1639.60
36	SEG[7]	X= 542.00	Y= -1641.00	78	PRTD[2]	X= -495.90	Y= 1639.60
37	SEG[6]	X= 657.50	Y= -1641.00	79	PRTD[1]	X= -611.50	Y= 1639.60
38	SEG[5]	X= 773.00	Y= -1641.00	80	PRTD[0]	X= -727.00	Y= 1639.60
39	SEG[4]	X= 888.50	Y= -1641.00	81	PRTC[3]	X= -842.50	Y= 1639.60
40	SEG[3]	X= 1004.00	Y= -1641.00	82	PRTC[2]	X= -958.00	Y= 1639.60
41	SEG[2]	X= 1119.50	Y= -1641.00	83	PRTC[1]	X= -1073.50	Y= 1639.60
42	SEG[1]	X= 1235.00	Y= -1641.00				



H. DC/AC Characteristics

Absolute Maximum Rating

Item	Sym.	Rating	Condition
Supply Voltage	V_{dd}	-0.5V ~ 8V	
Input Voltage	V_{in}	-0.5V ~ $V_{dd}+0.5V$	
Output Voltage	V_o	-0.5V ~ $V_{dd}+0.5V$	
Operating Temperature	T_{op}	0°C ~ 70°C	
Storage Temperature	T_{st}	-50°C ~ 100°C	

Recommended Operating Conditions

Item	Sym.	Rating	Condition
Supply Voltage	V_{dd}	2.2V ~ 5.5V	
Input Voltage	V_{ih}	0.9 V_{dd} ~ V_{dd}	
	V_{il}	0.0V ~ 0.1 V_{dd}	
Operating Frequency	F_{max}	8MHz	$V_{dd}=5.0V$
		4MHz	$V_{dd}=2.2V$
Operating Temperature	T_{op}	0°C ~ 70°C	
Storage Temperature	T_{st}	-50°C ~ 100°C	



Testing Condition : TEMP=25°C, VDD=3V+/-10%, GND=0V

	PARAMETER		CONDITION	MIN	TYP	MAX	UNIT
I_{Fast}	NORMAL Mode Current	System	2M ext. R/C		0.75	1	mA
I_{Slow}	SLOW Mode Current	System	32.768K X'tal LCD Disable		10	20	μA
I_{Idle}	IDLE Mode Current	System	32.769K X'tal LCD Disable		6	10	μA
I_{LCD}	Extra Current if LCD ON	System	LCD Enable, LCD option=300Kohm Voltage-doubler OFF		12	20	μA
			LCD Enable, LCD option=30Kohm, Voltage-doubler ON		100	120	
I_{Sleep}	Sleep Mode Current	System				1	μA
I_{oHPWM}	PWM Output Drive Current	PWMP, PWMN*2	V _{DD} =3V; V _{oh} =2V	12	15		mA
I_{oLPWM}	PWM Output Sink Current	PWMP, PWMN*2	V _{DD} =3V; V _{oL} =1V	33	40		mA
I_{oVO}	DAC Output Current	VO	V _{DD} =3V; VO=0~2V, Data=7F	2.5	3		mA
V_{iH}	Input High Voltage	I/O pins		0.8 V _{DD}			V
V_{iL}	Input Low Voltage	I/O pins				0.2 V _{DD}	V
V_{hys}	Input Hysteresis Width	I/O, RSTP_N	Threshold=2/3V _{DD} (input from low to high) Threshold=1/3V _{DD} (input from high to low)		1/3 V _{DD}		V
I_{oH}	Output Drive Current	I/O pull-high*1	V _{oL} =2.0V	50			μA
I_{oL_1}	Output Sink Current	I/O pull-low*1	V _{oL} =0.4V	1.0			mA
I_{iL_1}	Input Low Current	RSTP_N	V _{iL} =GND, pull high Internally		20		μA
I_{iL_2}	Input Low Current	I/O	V _{iL} =GND, if pull high Internally by user		100		μA

Note: *1: Drive Current Spec. for Push-Pull I/O port only

Sink Current Spec. for both Push-Pull and Open-Drain I/O port.

*2: This Spec. base on one driver only. There are five build-in driver, so user just multiply the number of driver he used to one driver current to get the total amount of current. ($I_{0HPWM} \cdot I_{0LPWM} * N$; $N=0,1,2,3,4,5$)

I. Application Circuit

Tripple Charge Pump is selected
 LCD Max. Voltage=LV3=3/2*VDD

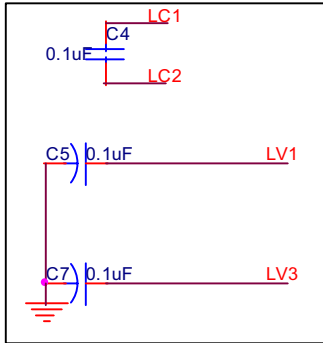

Tripple Charge Pump is selected
 LCD Max. Voltage=LV3=VDD

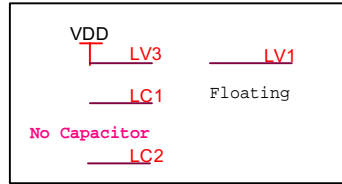

No External Parts is necessary if user adopt Internal Fast RC Clock

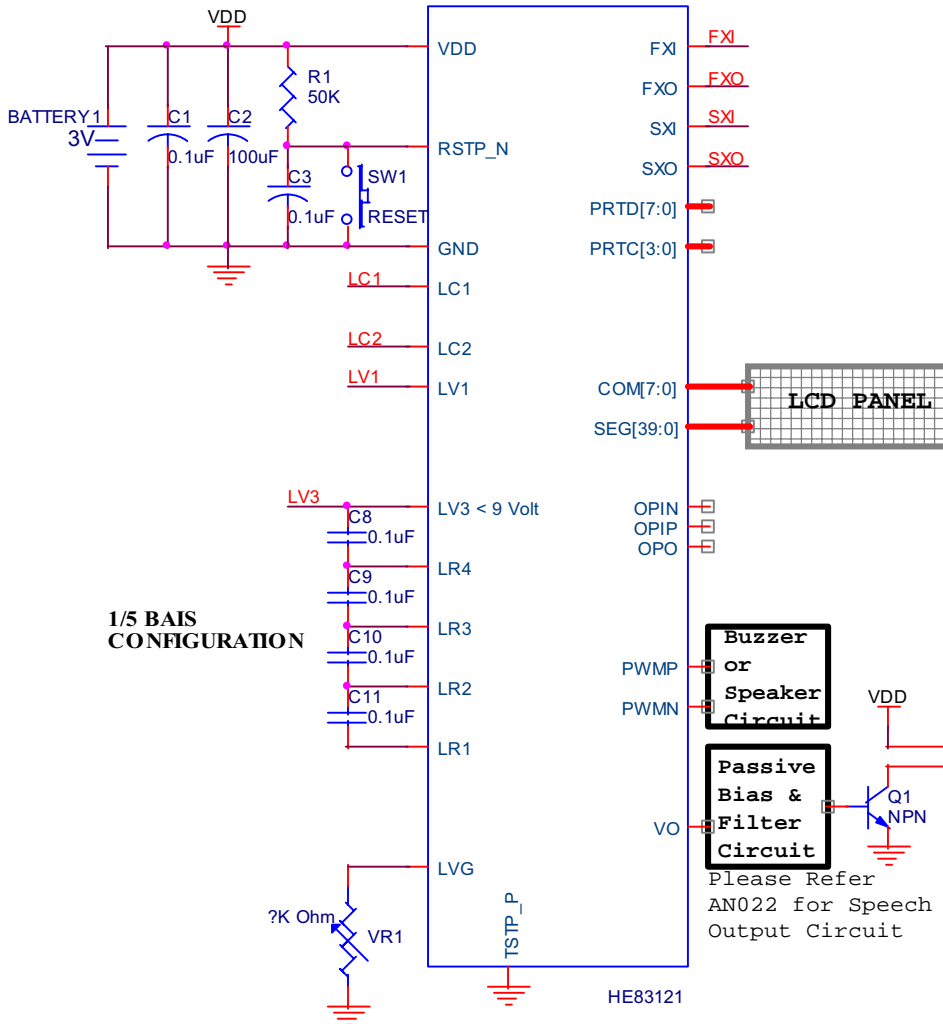

External Fast Clock:
 Crystal osc.

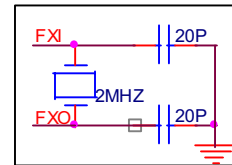

External Fast Clock:
 RC osc.

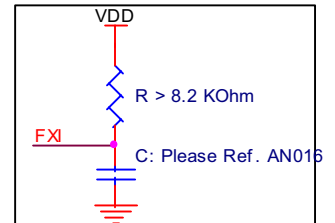

External Slow Clock:
 Crystal osc.

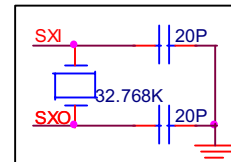

External Slow Clock:
 RC osc.

