

GBS-9010FG (RoHS Compliant)

5V / 1310 nm / 2.125 Gb/s Single-Mode Gigabit Interface Converter (GBIC)

FEATURES

- | Up to 2.5 Gbps Bi-directional Data Links
- | Compliant with 1X / 2X Fibre Channel FC-PI 13.0
- | Compliant with Gigabit Interface Converter (GBIC) Specification Rev. 5.5
- | 1310 nm Laser Transmitter
- | Link Distance up to 10 km
- | Hot Pluggable module with Duplex SC Connector
- | Multi-rate Operation for 2.5 / 2.125 / 1.062 / 1.25 Gbps
- | Link Distance up to 10 km
- | SCA-2 Host Connector
- | Single +5 V Power Supply
- | RoHS Compliant
- | Differential PECL Inputs and Outputs
- | TTL RX-LOS Output
- | Class 1 Laser International Safety Standard IEC 60825 Compliant

DESCRIPTION

The GBS-9010FG series optical transceivers meet the Gigabit Interface Converter (GBIC) specification Rev. 5.5. It satisfies the optical interface specifications defined in IEEE 802.3z Drift 5.0 1000 BASE-LX for Gigabit Ethernet and 1x / 2x Fibre Channel FC-PI 13.0. This module is designed for single-mode fiber and operates at a nominal wavelength of 1310 nm. The transmitter section uses a multiple quantum well laser and is a class 1 laser compliant according to International Safety Standard IEC 60825. The receiver section uses an integrated InGaAs detector preamplifier (IDP) mounted in an optical header and a limiting post-amplifier IC. A PECL input / output logic interface is used. TTL RX-LOS output simplifies interface to external circuitry. A 20-pin SCA-2 host connector is used to connect the converter to the host system.

LASER SAFETY

This single mode transceiver is a Class 1 laser product. It complies with IEC 60825 and FDA 21 CFR 1040.10 and 1040.11. The transceiver must be operated within the specified temperature and voltage limits. The optical ports of the module shall be terminated with an optical connector or with a dust plug.

APPLICATIONS

- | Switch to Switch Interface
- | High Speed Interface for File Servers
- | Data Storage
- | Dual Rate 1.06 / 2.125 Gb/s Fibre Channel

ORDER INFORMATION

P/No.	Bit Rate (Gb/s)	FC-PI	Distance (km)	Wavelength (nm)	Package	Temp. (°C)	TX Power (dBm)	RX Sens. (dBm)	RoHS Compliant
GBS-9010F	2.125/1.063	200/100	10	1310	SC GBIC	0 to 70	-3 to -8	-21	Yes

Absolute Maximum Ratings

Parameter	Symbol	Min	Max	Units	Notes
Storage Temperature	T _{stg}	-40	85	°C	
Operating Temperature	T _{opr}	-5	70	°C	Air flow 1m/sec
Power Supply Voltage	V _{cc}	-0.5	6	V	
Input Voltage	---	-0.5	V _{cc}	V	

Recommended Operating Conditions

Parameter	Symbol	Min	Typ	Max	Units	Conditions
Power Supply Voltage	V _{cc}	4.75	5	5.25	V	Reference to GND.
Power Supply Current	I _{TX} + I _{RX}		200	300	mA	
Operating Temperature	T _{opr}	0		70	°C	Air flow 1m/sec
Data Rate			1.0625 / 1.25 2.125 / 2.5	2.5	Gb/s	
Fiber Length on 9/125 μm SMF	2			10,000	m	@1.0625 / 2.125 Gb/s

Transmitter Specifications (0°C < Topr < 70°C, 4.75 V < Vcc < 5.25V)

Parameter	Symbol	Min	Typ	Max	Units	Notes
Optical						
Optical Transmit Power	Po	-8	---	-3	dBm	1
Output Center Wavelength	λ	1285	1310	1340	nm	
Output Spectrum Width	$\Delta\lambda$		---	2.0	nm	RMS (σ)
Extinction Ratio	E _R	9		---	dB	
Optical Modulation Amplitude (Peak-to-Peak)	OMA	196			μ W	FC-PI Standard
Optical Rise Time	t _r			150	ps	20% to 80% value
Optical Fall Time	t _f			150	ps	20% to 80% value
Pout TX_Disable Asserted	P _{OFF}			-35	dBm	
Electrical						
Differential Input Voltage	V _{IH} - V _{IL}	0.65		2.0	V _{p-p}	
Transmit Fault Load	TX-FAULT _{LOAD}	4.7		10	k Ω	2
Transmit Fault Output-Low	V _{TX-FAULT-L}	0.0		0.5	V	
Transmit Fault Output-High	V _{TX-FAULT-H}	V _{cc} - 0.5		V _{cc} + 0.3	V	
TX-Disable Input - Low	V _{TX-DISABLE-L}	0		0.8	V	
TX-Disable Input - High	V _{TX-DISABLE-H}	2.0		V _{cc} + 0.3	V	
TX-Disable Assert Time	t _{off}			10	μ s	
TX-Disable Negate Time	t-on			1	ms	
Time to initialize, includes reset of TX-FAULT	t-int			300	ms	
TX FAULT from fault to assertion	t-fault			100	μ s	
TX-Disable time to start reset	t-reset	10			μ s	

1. Output power is power coupled into a 9/125 μ m SM fiber.
2. Pull-up resistor on host Vcc.

Receiver Specifications (0°C < Topr < 70°C, 4.75 V < Vcc < 5.25V)

Parameter	Symbol	Min	Typ	Max	Units	Notes
Optical						
Sensitivity @1.25Gb/s @ BER=10 ⁻¹²	Sens (1X)	---	---	-22	dBm	3
Sensitivity @2.125Gb/s @ BER=10 ⁻¹²	Sens (2X)			-21	dBm	3
Maximum Input Power	Pin	-3		---	dBm	3
Signal detect – Hysteresis		1.0	---		dB	
Wavelength of Operation		1200	---	1600	nm	
RX-LOS – Asserted	Pa	---	---	-21	dBm	Transition: low to high
RX-LOS – Deasserted	Pd	-31	---	---	dBm	Transition: high to low
Electrical						
Differential Output Voltage	\pm RX-DAT	0.37		2.0	V _{p-p}	
Data Output Rise Time	T _{IRX-DAT}			0.35	ns	
Data Output Fall Time	T _{FRX-DAT}			0.35	ns	
Receiver Loss of Light Load	RX-LOS _{LOAD}	4.7		10	k Ω	4
Loss of Signal Output Voltage --- Low	RX-LOS _L	0		0.5	V	
Loss of Signal Output Voltage --- High	RX-LOS _H	2.4		V _{cc}	V	
Loss of Signal Assert Time (off to on)	T _{A,RX-LOS}			100	μ s	
Loss of Signal Deassert Time (on to off)	T _{D,RX-LOS}			100	μ s	

3. Minimum sensitivity and saturation levels at BER=1E-12 for a 2⁷-1 PRBS.
4. Pull-up resistor on host Vcc.

PIN ASSIGNMENT

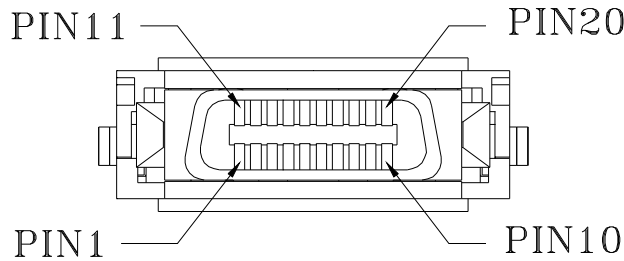

PIN	Signal Name	Sequence	Description
1	RX-LOS	2	Receiver Loss of Signal, logic high, open collector compatible, 4.7K to 10K ohm pull-up to V _{CC} T on host
2	R _{GND}	2	Receiver Ground
3	R _{GND}	2	Receiver Ground
4	MOD-DEF(0)	2	TTL Low
5	MOD-DEF(1)	2	SCL Serial Clock Signal
6	MOD-DEF(2)	2	SDA Serial Data Signal
7	TX-DIABLE	2	Transmitter Disable, logic high, open collector compatible
8	T _{GND}	2	Transmitter Ground
9	T _{GND}	2	Transmitter Ground
10	TX-FAULT	2	Transmitter Fault, logic high, open collector compatible, 4.7K to 10K ohm pull-up to V _{CC} T on GBIC
11	R _{GND}	1	Receiver Ground
12	-RX-DAT	1	Receiver Data Bar, Differential PECL, AC coupled
13	+RX-DAT	1	Receiver Data, Differential PECL, AC coupled
14	R _{GND}	1	Receiver Ground
15	V _{CC} R	2	Receiver +5V Supply
16	V _{CC} T	2	Transmitter +5V Supply
17	T _{GND}	1	Transmitter Ground
18	+TX-DAT	1	Transmitter Data, Differential PECL, AC coupled
19	-TX-DAT	1	Transmitter Data Bar, Differential PECL, AC coupled
20	T _{GND}	1	Transmitter Ground

A sequence value of 1 indicates that the signal is in the first group to engage during plugging of a module. A sequence value of 2 indicates that the signal is the second and last group. The two guide pins on the connector are electrically connected to the transceiver circuit ground. These two guide pins make contact with circuit prior to sequence 1 signals.

Module Definition

Module Definition	MOD-DEF(0) PIN 4	MOD-DEF (1) PIN 5	MOD-DEF (2) PIN 6	Interpretation by Host
4	TTL Low	SCL	SDA	Serial module definition protocol

Module Definition 4 specifies a serial definition protocol. For this definition, upon power up, MOD-DEF(1:2) appear as no connector (NC) and MOD-DEF(0) is TTL LOW. When the host system detects this condition, it activates the serial protocol. The protocol uses the 2-wire serial CMOS E²PROM protocol of the ATMEL AT24C01A/02/04 family of components.

PACKAGE DIAGRAM

Units in mm

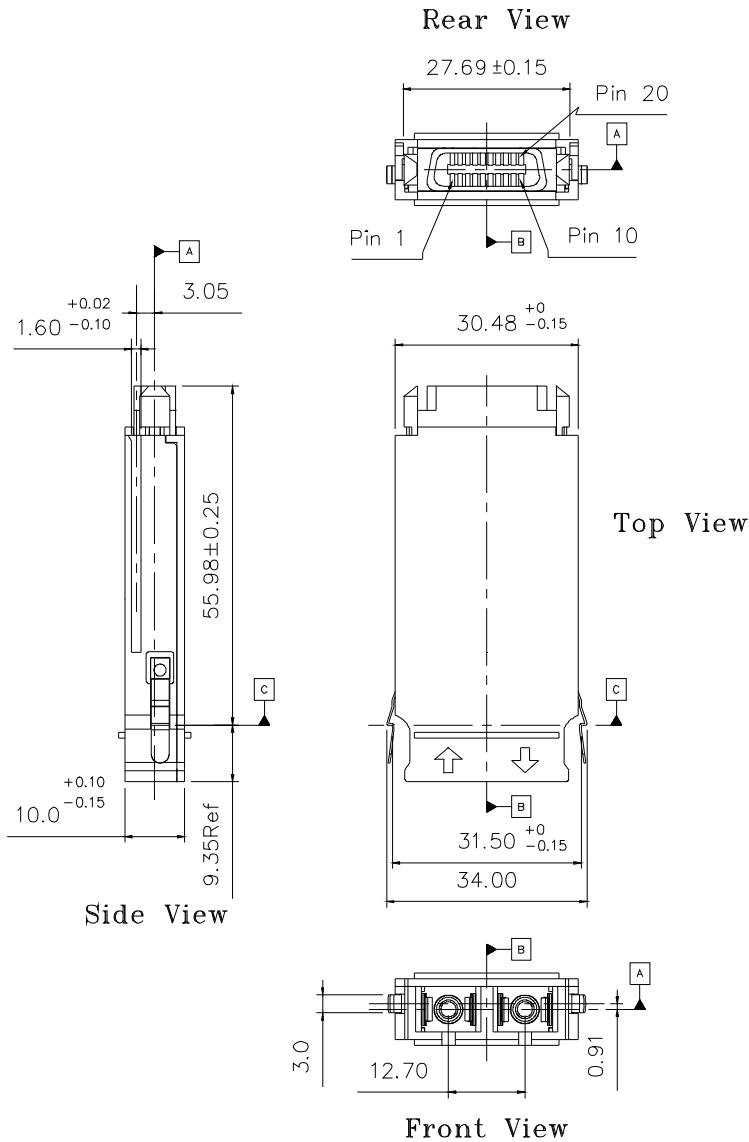

Note: Specifications subject to change without notice.