

High Sensitivity 10Gb/s surface mount coplanar APD preamp receiver

AT10XGC

The AT10XGC receiver consists of an avalanche photodiode, a low-noise preamplifier and a precision NTC thermistor in a hermetic coplanar package with a connectorized single-mode fiber pigtail. Differential outputs are provided to improve noise rejection for enhanced sensitivity. It has been optimised for use in 10Gb/s metro or long-haul applications, either as a discrete device or within a transponder, using NRZ modulation, with or without FEC, at data rates up to 10.709Gb/s.

Features:

- High sensitivity, -28.5dBm typical
- Low capacitance high speed InGaAs APD photodetector
- Supports FEC rates up to 10.709Gb/s
- Best in class power consumption, only 300mW
- Designed to exceed the environmental requirements of Telcordia GR-468-CORE
- RoHS 5/6 compliant 

Applications:

- Client or line side links
- 300 pin LR transponder applications
- Yellow fiber pigtail for MSA compliance

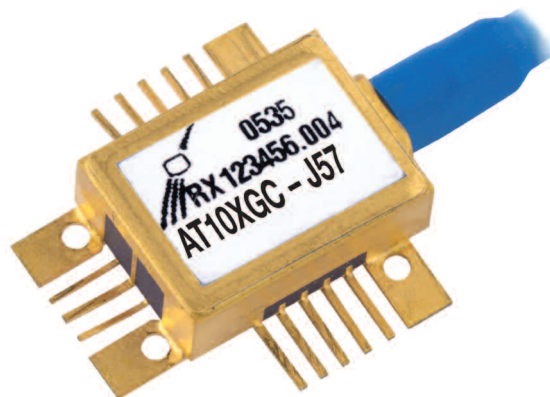

Operating Characteristics

Case Temperature = 25°C unless otherwise specified

Parameter	Symbol	Measurement Conditions	Min	Typ	Max	Unit
Optical sensitivity BOL [1] [2]	Sens	2 ³¹ -1 PRBS BER<10 ⁻¹² V _{optimal} = VM ₁₀		-28.5	-27.0	dBm
Sensitivity penalty EOL over temperature [1] [2]		2 ³¹ -1 PRBS BER<10 ⁻¹² V _{optimal} = VM ₁₀ T=0 to +85°C		0.75	1.0	dB
Deviation from linear phase		DC - 6GHz	-10		+10	°
High frequency -3dB corner	f _H	V _{APD} =VM ₁₀ Small signal	8	9		GHz
Low frequency -3dB corner	f _L				40	kHz
Transimpedance gain [3] [4] [5]	T _Z	Small signal	2.3	4.0	5.7	kΩ
Maximum output voltage [6]	V _{OUT}	Peak-to-peak			165	mV
Return loss	S ₂₂	DC to 6.0GHz			-8	dB
Optical overload [2]	P _{SAT}	2 ²³ -1 PRBS V _{APD} =VM ₃ BER<10 ⁻¹²	-3	-1		dBm
APD breakdown voltage	V _{br}	T=25°C I _{APD} =10mA	20		40	V
APD breakdown voltage temperature coefficient	T _{vbr}		0.030		0.061	V/°C
Dark current	I _d	At 90% of V _{br}			100	nA
Amplifier bias current	I _{cc}			55	73	mA
Input current for output limiting	I _{in lim}	Peak-to-peak		80		uA
Transimpedance amp supply voltage	V _{TZA}			3.3		V
Thermistor resistance	R _{TH}	T=25°C		10		kΩ

Notes:

- [1] Optical Wavelength between 1525-1575nm. Data to 1610nm available on request.
- [2] Measured with 9.95Gb/s, extinction ratio > 12dB, Q factor > 30, 50% crossing level, 1550nm.
- [3] Load impedance is 50Ω AC-coupled.
- [4] Excludes APD responsivity.
- [5] Differential.
- [6] Single ended.

Absolute Maximum Ratings

The table below provides maximum and/or minimum values of critical parameters which will not permanently damage the device, but for which the operating specification may not hold.

Parameter	Symbol	Min	Max	Unit
Amplifier bias voltage	V_{CC}	-0.7	5.0	V
Operating temperature [1]	T_{op}	0	+85	°C
Storage temperature [2]	T_{stg}	-40	+85	°C
Input photocurrent [3]	I_{PD}		3	mA
APD bias voltage	V_{APD}	0	V_{br}	V
Fiber bend radius		20		mm

Notes:

[1] The operating temperature is defined as the temperature of the module case.

[2] The rating is referred to the ambient temperature.

[3] $V_{APD} \cdot V_{M3}$. Although implementation of a current limit is intuitive, it is not recommended as biasing below the specified $M = 3$ voltage in the presence of a high optical power has been shown to cause device damage.

Class 2 ESD precautions must be observed when handling these devices.

Pin Out

Pin #	Symbol	Parameter	Pin #	Function	Parameter
1	GND	Case ground	10	Out_P	Positive RF data output
2	V_{APD}	APD bias voltage	11	GND	Case RF ground
3	NC	No connection	12	GND	Case ground
4	NC	No connection	13	NC	No connection
5	NC	No connection	14	V_{CC}	Amplifier supply (+3.3V)
6	GND	Case ground	15	NC	No connection
7	GND	Case RF ground	16	RTH	Thermistor
8	Out_N	Negative RF data output	17	GND	Case ground
9	GND	Case ground			

Deliverable Data

V_{M3} and V_{br} are provided on the fiber tag for each device.

Circuit Schematic

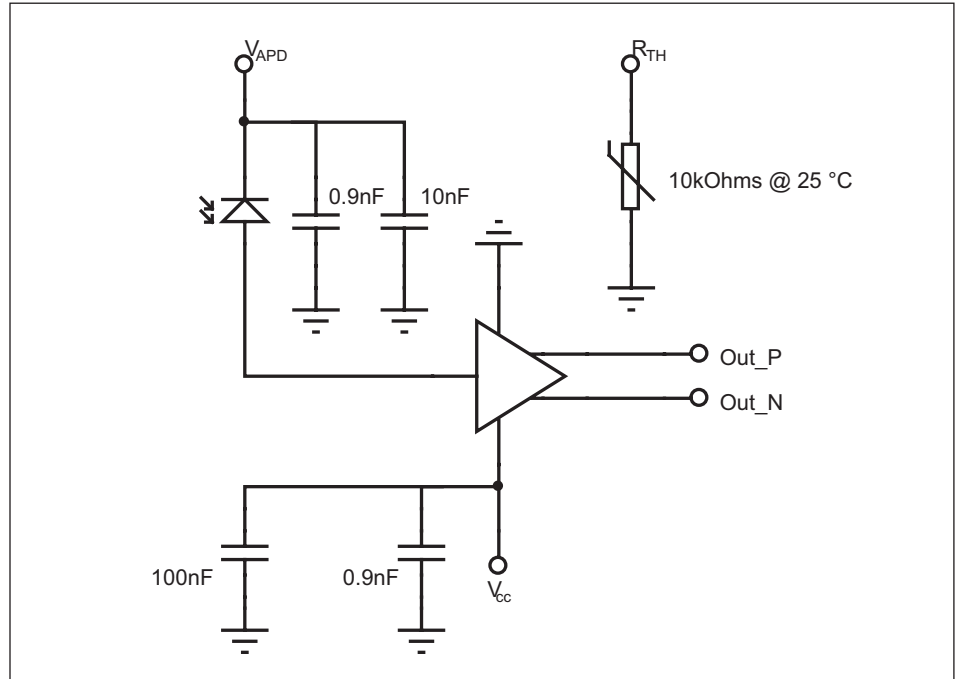

Figure [1] AT10XGC Circuit schematic.

Outline Drawing

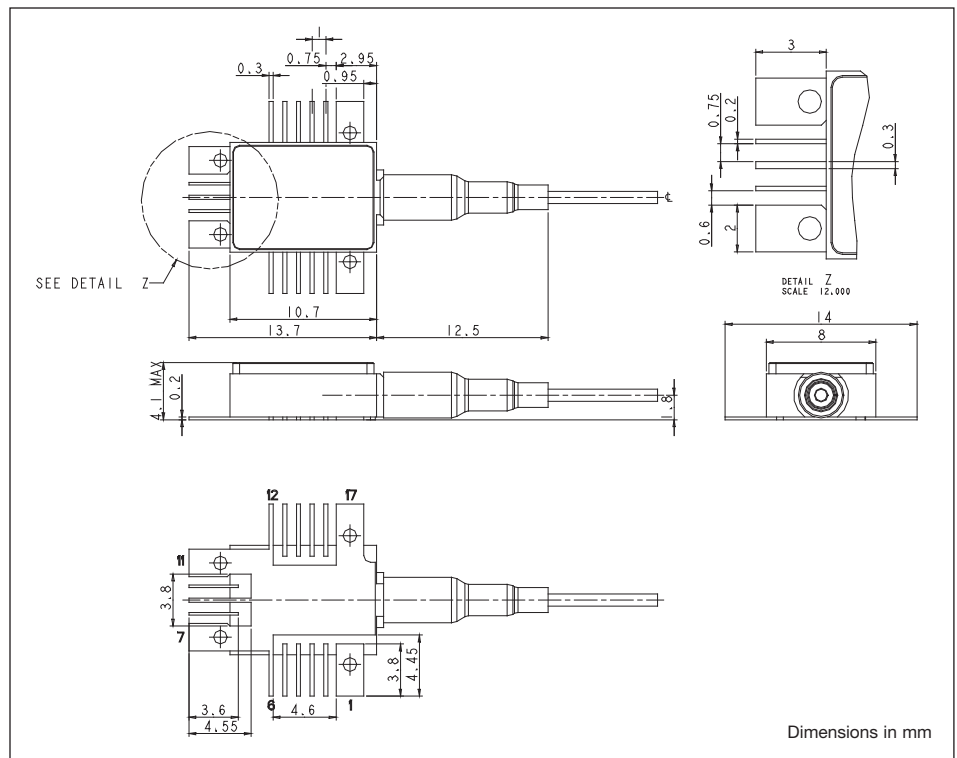

Figure [2] Outline diagram (Illustration only. For full details, refer to appropriate assembly drawing.)
Note: Fiber is 900mm yellow secondary coated single-mode fiber, length = 1100 +/-200mm.

Typical Performance Characteristics

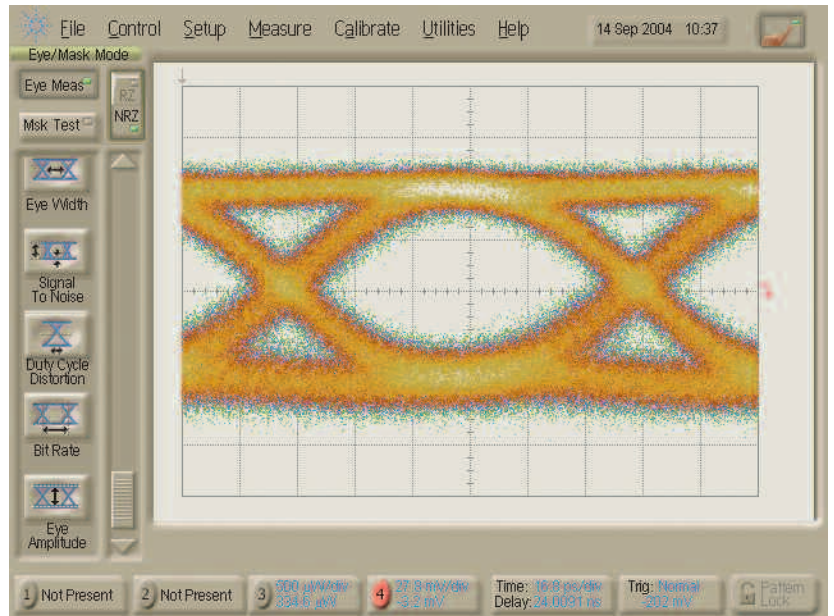

Figure [3] Electrical output data eye, M = 10, 10Gb/s $2^{31}-1$ PRBS, -28dBm optical input.

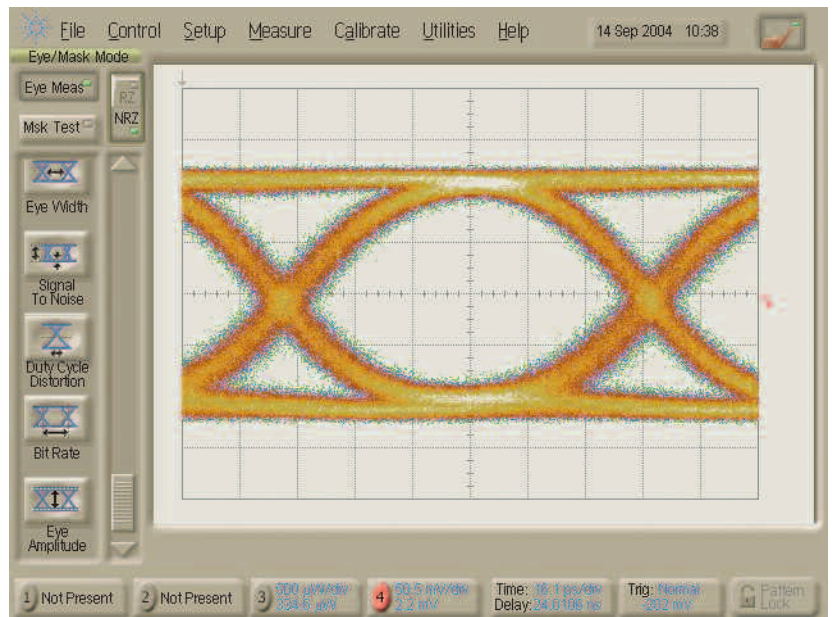

Figure [4] Electrical output data eye, M = 10, 10Gb/s $2^{31}-1$ PRBS, -24dBm optical input.

Typical Performance Characteristics (continued)

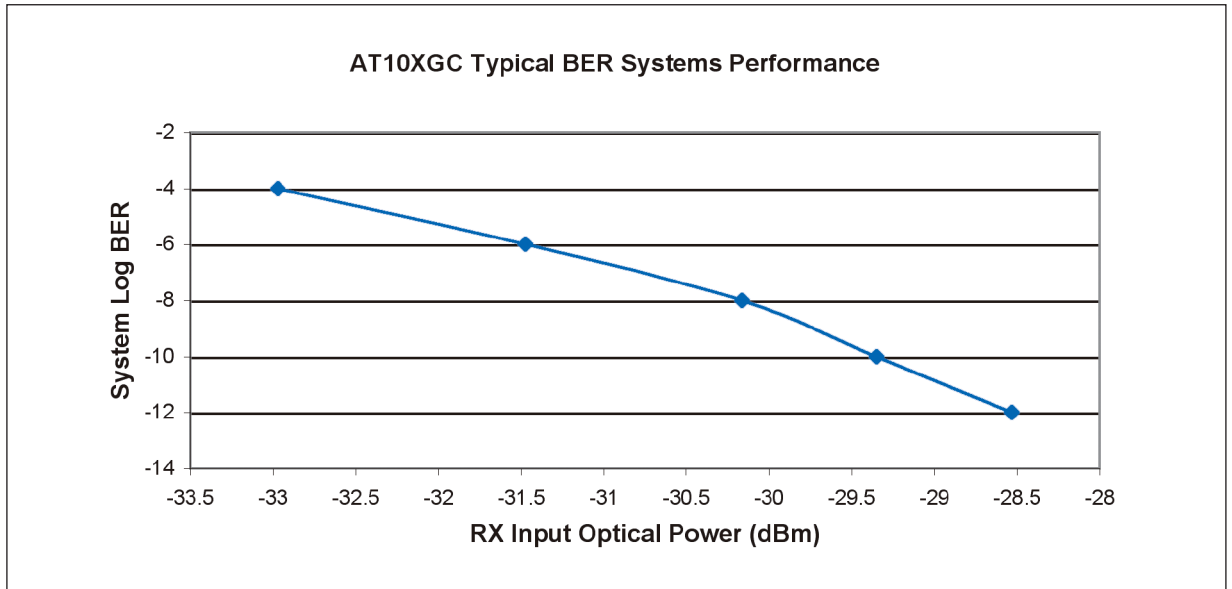

Figure [5] Typical BER performance, measured with 9.95Gb/s 2³¹-1 PRBS, extinction ratio > 12dB, Q factor > 30, 50% crossing level, 1550nm at 25°C.

RoHS Compliance



Bookham is fully committed to environment protection and sustainable development and has set in place a comprehensive program for removing polluting and hazardous substances from all of its products. The relevant evidence of RoHS compliance is held as part of our controlled documentation for each of our compliant products. RoHS compliance parts are available to order, please refer to the ordering information section for further details.

Ordering Information:

AT10XGC - (Connector)
 J = SC/PC
 J57 = LC

e.g. AT10XGC-J is an AT10XGC with an SC/PC connector.

Other options available on request

Contact Information

North America Bookham Worldwide Headquarters

2584 Junction Ave.
 San Jose
 CA 95134
 USA

- Tel: +1 408 919 1500
- Fax: +1 408 919 6083

www.bookham.com
sales@bookham.com

Europe Paignton Office

Brixham Road
 Paignton
 Devon
 TQ4 7BE
 United Kingdom

- Tel: +44 (0) 1803 66 2000
- Fax: +44 (0) 1803 66 2801

Asia Shenzhen Office

2 Phoenix Road
 Futian Free Trade Zone
 Shenzhen 518038
 China

- Tel: +86 755 33305888
- Fax: +86 755 33305805
 +86 755 33305807

Important Notice

Performance figures, data and any illustrative material provided in this data sheet are typical and must be specifically confirmed in writing by Bookham before they become applicable to any particular order or contract. In accordance with the Bookham policy of continuous improvement specifications may change without notice. The publication of information in this data sheet does not imply freedom from patent or other protective rights of Bookham or others. Further details are available from any Bookham sales representative.

