

**AKM AK4182A Touch Screen Controller**

**Features:**

- 12 bit SAR type A/D Converter with S/H circuit
- Low Voltage Operation (VCC = 2.2V ~ 3.6V)
- Low Voltage Digital I/F (1.5V ~ VCC)
- 4-wire I/F
- Sampling Frequency: 125 kHz (max)
- On-Chip Voltage Reference (2.5V)
- Pen Pressure Measurement
- On-Chip Thermo Sensor
- Direct Battery Measurement
- Low Power Consumption (260µA)
- Package 16pin QFN

**General Description:**

The AK4182A is a 4-wire resistive touch screen controller that incorporates a 12-bit 125 kHz sampling SAR type A/D converter.

The AK4182A operates down to 2.2V supply voltage and supports digital I/O interface voltage from 1.5V to VCC in order to connect low voltage uP.

The AK4182A can detect the pressed screen location by performing two A/D conversions. In addition to location, the AK4182A also measures touch screen pressure.

On-chip VREF can be utilized for analog auxiliary input, temperature measurement and battery monitoring with the ability to measure voltage from 0V to 5V.

The AK4182A also has an on-chip temperature sensor.

The AK4182A is available in 16pin QFN thin package (0.75mm in height) and has the operating temperature range of -40°C to +85°C

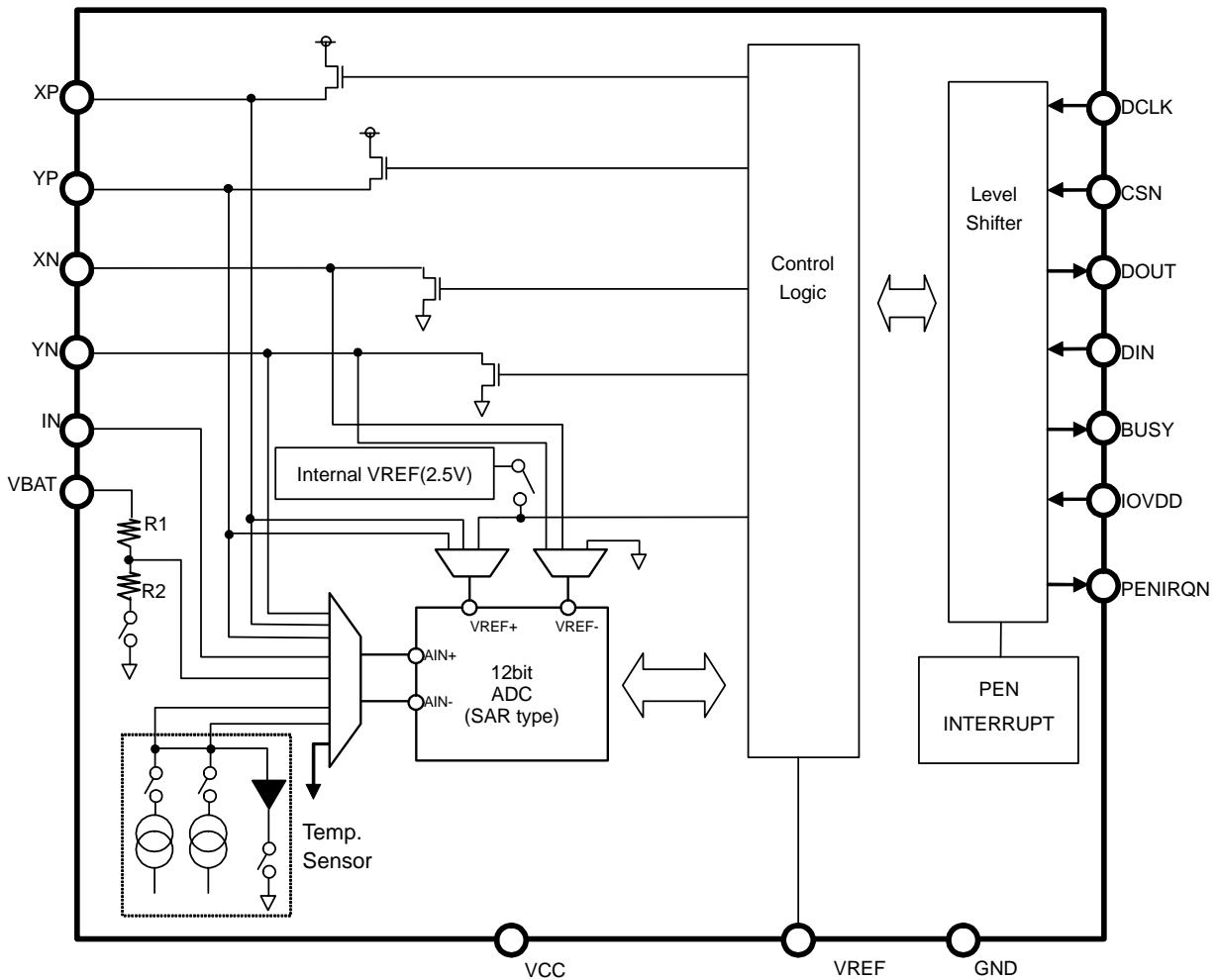

Block Diagram

■ Ordering Guide

AK4182AVN    -40°C ~ +85°C    16pinQFN

■ Pin Layout

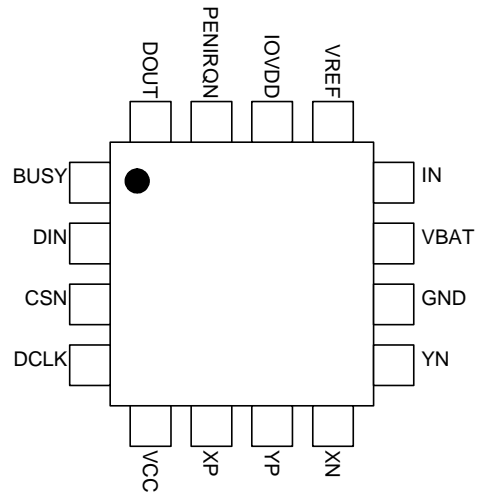

Pin/Function			
No.	Signal Name	I/O	Description
1	BUSY	O	BUSY Output This pin goes to low at CSN = "L". BUSY signal is "H" only for the period between the falling edge of 8 <sup>th</sup> DCLK and the falling edge of 9 <sup>th</sup> DCLK. This pin is Hi-Z state at CSN= "H"
2	DIN	I	Serial Data Input Inputs 8-bit control command data serially when CSN= "L" AK4182A latches at the rising edge of DCLK. Must keep "L" while not issuing commands.
3	CSN	I	Chip Select Input Enables writing data to the registers when CSN= "L".
4	DCLK	I	External Clock Input
5	VCC	-	Power Supply
6	XP	I/O	Touch Screen X+ plate Voltage supply <ul style="list-style-type: none"> <li>■ X axis Measurement: Supplies the voltage to X+ position input</li> <li>■ Y axis Measurement: This pin is used as the input for the A/D converter</li> <li>■ Pen Pressure Measurement: This pin is the input for the A/D converter at Z1 measurement.</li> <li>■ Temperature/VBAT/IN Measurement: OPEN state</li> <li>■ Pen Waiting State: Pulled up by an internal resistor (typ.50KΩ).</li> </ul>
7	YP	I/O	Touch Screen Y+ plate Voltage supply <ul style="list-style-type: none"> <li>■ Y axis Measurement: Supplies the voltage to Y+ position input</li> <li>■ X axis Measurement: This pin is used as the input for the A/D converter</li> <li>■ Pen Pressure Measurement: Supplies the voltage.</li> <li>■ Temperature/VBAT/IN Measurement: OPEN state</li> <li>■ Pen Waiting State: OPEN state</li> </ul>
8	XN	I/O	Touch Screen X- plate Voltage supply <ul style="list-style-type: none"> <li>■ X axis Measurement: Supplies the voltage to X- position input</li> <li>■ Y axis Measurement: OPEN state</li> <li>■ Pen Pressure Measurement: Supplies the voltage.</li> <li>■ Temperature/VBAT/IN Measurement: OPEN state</li> </ul>
9	YN	I/O	Touch Screen Y- plate Voltage supply <ul style="list-style-type: none"> <li>■ Y axis Measurement: Supplies the voltage to Y- position input</li> <li>■ X axis Measurement: OPEN state</li> <li>■ Pen Pressure Measurement: This pin is the input for the A/D converter at Z2 measurement.</li> <li>■ Temperature/VBAT/IN Measurement: OPEN state</li> <li>■ Pen Waiting State: connected to GND.</li> </ul>
10	GND	-	Ground
11	VBAT	I	Analog Input for Battery Monitor
12	IN	I	Auxiliary Analog Input
13	VREF	I/O	Voltage Reference Input/Output 2.5V reference voltage output at PD1 = "1". Voltage reference input at PD1 = "0".
14	IOVDD		Digital I/O Power Supply
15	PENIRQN	O	Pen Interrupt Output This pin is "L" during the pen down on pen interrupt enable state with CSN = "H" otherwise this pin is "H". This pin is "H" during pen interrupt disable state with the CSN = "H" regardless pen touch. See ■ Power-down Control and ■ Pen Interrupt for the reference.
16	DOUT	O	Serial A/D Data Output Output A/D data serially at the falling edge of DCLK. MSB is output at the falling edge of BUSY signal. Output "L" at CSN= "L" during A/D data does not output. This pin is Hi-Z state at CSN="H"

<b>Absolute Maximum Ratings</b>
---------------------------------

GND = 0V (Note 1)

Parameter	Symbol	Min	max	Units
Power Supplies	VCC	-0.3	6.0	V
Digital I/O Power Supply	IOVDD	-0.3	6.0	V
Input Current (any pins except for supplies)	IIN	-	±10	mA
Input Voltage	VIN	-0.3	6.0(VCC+0.3)	V
Touch Panel Drive Current	IOUTDRV		50	mA
Ambient Temperature (power supplied)	Ta	-40	85	°C
Storage Temperature	Tstg	-65	150	°C

Note 1. All voltages with respect to ground.

WARNING: Operation at or beyond these limits may result in permanent damage to the device.  
Normal operation is not guaranteed at these extremes.

<b>Recommended Operating Conditions</b>
---

GND = 0V (Note 1)

Parameter	Symbol	Min	typ	max	Units
Power Supplies	VCC	2.7	3.3	3.6	V
Digital I/O Power Supply	IOVDD	1.5	3.3	VCC	V

Note 1. All voltages with respect to ground.

WARNING: AKM assumes no responsibility for the usage beyond the conditions in this datasheet.

<b>Analog Characteristics</b>				
Ta=-40°C to 85°C, VCC = IOVDD = 2.7V, External Vref=2.5V, fs = 125 KHz, fDCLK = 16 x fs, 12bit mode				
<b>Parameter</b>	<b>min</b>	<b>typ</b>	<b>max</b>	<b>Units</b>
<b>ADC for Touch Screen</b>				
Resolution		12		Bits
No Missing Codes	11	12		Bits
Integral Nonlinearity (INL) Error			±2	LSB
Differential Nonlinearity (DNL) Error		±1		LSB
Analog Input Voltage Range	0		Vref	V
Offset Error			±6	LSB
Gain Error			±4	LSB
Touch Panel Driver XP, YP, RL=300Ω XN, YN, RL=300Ω		5 5		Ω Ω
XP Pull Up Register (when pen interrupt enable)		50		KΩ
PSRR (10KHz 100mVpp)		70		dB
<b>Reference Output</b>				
Internal Reference	2.44	2.50	2.56	V
Drift		30		ppm/°C
Load Capacitance	0.1			μF
<b>Reference Input</b>				
Input Voltage Range			VCC	V
<b>Battery Monitor</b>				
Input Voltage Range			5.0	V
Input Impedance (Battery Measure Mode)	5	10		KΩ
Accuracy (Note 2) External VREF = 2.5V is used			±2	%
Accuracy (Note 2) Internal Reference is used.			±3	%
<b>Temperature Measurement</b>				
Temperature Range	-40		85	°C
Resolution (Note 3)		1.6		°C
Accuracy (Note 4)		±3		°C
<b>Power Supply Current</b>				
Normal Mode (Internal Reference OFF)		260	500	μA
Normal Mode (Internal Reference ON)		540	800	μA
Full Power Down(when writing control command with PD1=PD0= "0")		0	3	μA

Note 2. Accuracy is the difference between the output code when 5 volts is input to the VBAT pin and the "ideal" code at 1.25 volts.

Note 3. "Ideal" value derived from theory

Note 4. Accuracy is defined as the difference between the voltage measured by two current sources, and the ideal voltage derived from theory at specific temperatures.

**DC Characteristics (Logic I/O)**

Ta = -40°C to 85°C, IOVDD = 1.5V to 3.6V

Parameter	Symbol	min	typ	max	Units
“H” level input voltage	VIH	0.8xIOVDD	-		V
“L” level input voltage	VIL		-	0.2xIOVDD	V
Input Leakage Current	IILK	-10		10	μA
“H” level output voltage (@ Iout = -250μA)	VOH	IOVDD-0.4	-		V
“L” level output voltage (@ Iout= 250μA)	VOL	-	-	0.4	V
Tri-state Leakage Current All pins except for XP, YP, XN, YN pins XP, YP, XN, YN pins	IOLK	-10 -50		10 50	μA μA

**Switching Characteristics**

Ta = -40°C to 85°C, VCC = 2.2V to 3.6V, IOVDD = 1.5V to VCC, CL = 50pF

Parameter	Symbol	min	typ	max	Units
<b>Touch Panel (A/D Converter)</b>					
Throughput Rate	fs			125	kHz
DCLK frequency	fDCLK	10		2100	kHz
DCLK duty	duty	40	50	60	%
Tracking Time (Rin=600Ω) (Note 5)	tTRK	1.428			μs
Conversion Time	tCONV			12	1/fDCLK
CSN “↓” to First DCLK “↑”	t1	100			ns
CSN “↓” to BUSY Tri-State Disabled	t2			200	ns
CSN “↓” to DOUT Tri-State Disabled	t3			200	ns </td
DCLK High Pulse Width	t4	190			ns
DCLK Low Pulse Width	t5	190			ns
DCLK “↓” to BUSY “↑”	t6			160	ns
Data Setup Time	t7	100			ns
Data Valid to DCLK Hold Time	t8	10			ns
Data Access Time after DCLK “↓”	t9			160	ns
CSN “↑” to DCLK Ignored	t10	0			ns
CSN “↑” to BUSY Hi-Z state	t11			200	ns
CSN “↑” to DOUT Hi-Z state	t12			200	ns

Note 5. The actual tracking periods are 3tDCLK. (tDCLK=1/fDCLK)

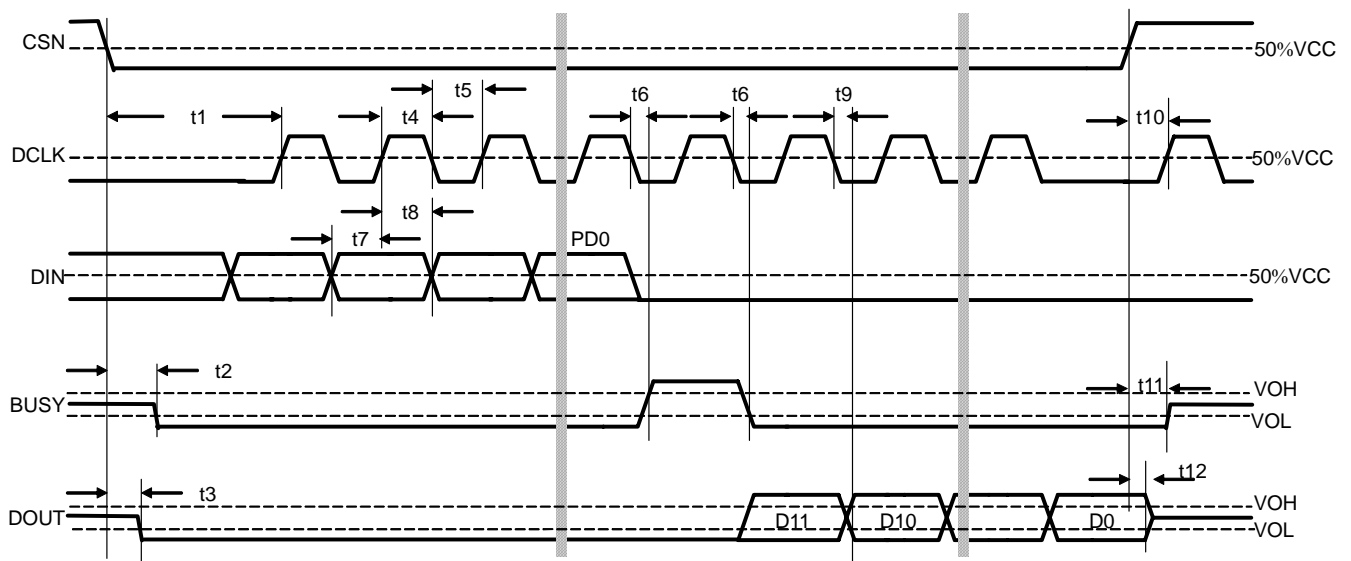

Figure 1 AK4182A Timing Diagram

## ■ A/D Converter for Touch Screen

The AK4182A incorporates a 12-bit successive approximation resistor (SAR) A/D converter for position measurement, temperature, and battery voltage. The architecture is based on capacitive redistribution algorithm, and an internal capacitor array functions as the sample/hold (S/H) circuit.

The SAR A/D converter output is a straight binary format as shown below:

Input Voltage	Output Code
$(\Delta VREF - 1.5LSB) \sim \Delta VREF$	FFFH
$(\Delta VREF - 2.5LSB) \sim (\Delta VREF - 1.5LSB)$	FFEH
-----	-----
0.5LSB $\sim$ 1.5LSB	001H
0 $\sim$ 0.5LSB	000H

$$\Delta VREF: (VREF+) - (VREF-)$$

Table 1 Output Code

The full scale ( $\Delta VREF$ ) of the A/D converter depends on the input mode. The AK4182A is controlled by the 8 bit serial command on DIN.

## ■ Analog Inputs

Analog input is selected via the A2, A1, A0 and  $\overline{SER/DFR}$  bits in the control register. If the analog inputs are selected to the X or Y-axis,  $\overline{SER/DFR} = "0"$ , which means differential mode, the full scale ( $\Delta VREF$ ) is the differential voltage between the non-inverting terminal and the inverting terminal of the measured axis (e.g. X-axis measurement : $(XP) - (XN)$ ). Analog non-inverting input to A/D converter is the non-inverting terminal of the non-measured axis while the inverting input is the inverting terminal of the measured axis. If the  $\overline{SER/DFR}$  bit is set to "1" which means single-ended mode, the full scale of A/D converter ( $\Delta VREF$ ) is the internal reference voltage or external reference voltage. Note that  $\overline{SER/DFR}$  bit should be set to "0" if IN2 is selected as analog input; nevertheless, IN2 is actually measured by single-ended mode.

Tracking time is the period from the falling edge of 5<sup>th</sup> DCLK to that of 8<sup>th</sup> DCLK after the detection of START bit during CSN="L".

The required settling time to charge the internal capacitor array depends on the source impedance ( $R_{in}$ ). If the source impedance is 600 $\Omega$ , the settling time needs at least 1.428 $\mu$ s (3tDCLK at 2.1MHz). The maximum throughput of A/D converter is 125 kHz.

If the source impedance of analog input or battery input is larger than 600 $\Omega$ , longer tracking time is required.

## ■ The Position Detection of Touch Screen

The position on the touch screen is detected by taking the voltage of one axis when the voltage is supplied between the two terminals of another axis. At least two A/D conversions are needed to get the two-dimensional (X/Y axis) position.

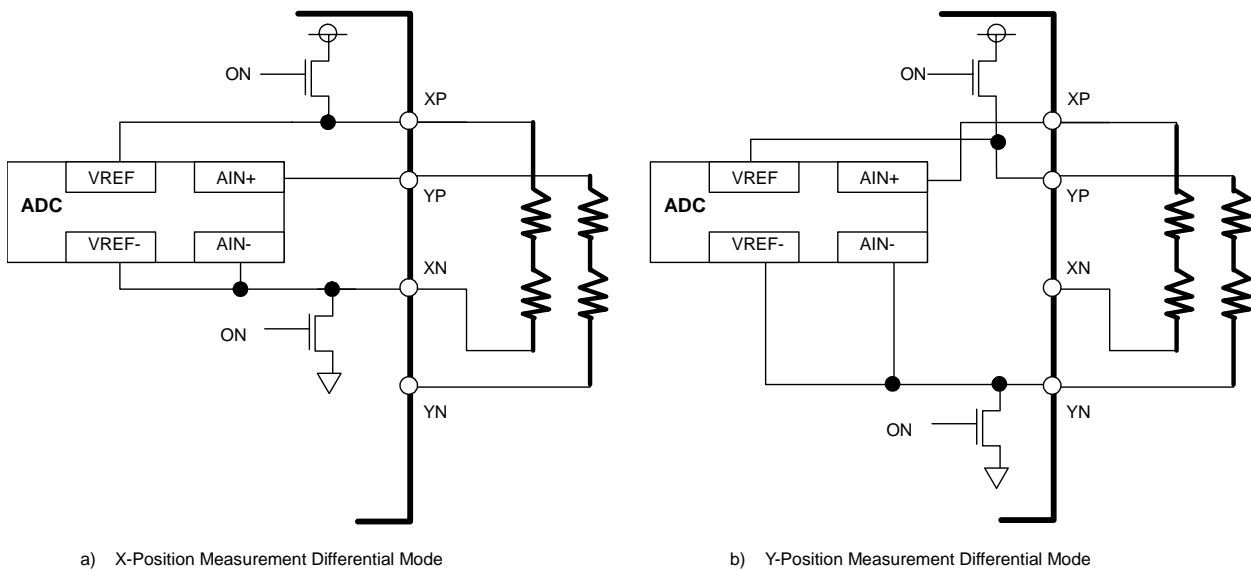

Figure 2 Axis Measurement

The differential mode position detection is typically more accurate than the single-ended mode. As the full scale of single-ended mode is fixed to the internal (or external) reference voltage, input voltage may exceed the full-scale reference voltage. This problem does not occur in differential mode. In addition to this, the differential mode is less influenced by power supply voltage variation due to the ratio-metric measurement.

However, note that the touch screen driver switch is still ON and the current flows even for the A/D conversion time. On the other hand, the touch screen driver switch is ON only for the tracking time, 3tDCLK. From the point of power consumption, single-ended mode has more advantages. However the differential mode is generally used to get more accurate measurement in position detecting.

■ The Pen Pressure Measurement

The touch screen pen pressure can be derived from the measurement of the contact resistor between two plates. The contact resistance depends on the size of the depressed area and the pressure. The area of the spot is proportional to the contact resistance. This resistance (Rtouch) can be calculated using two different methods.

The first method is that when the total resistance of the X-plate sheet is already known. The resistance, Rtouch, is calculated from the results of three conversions, X-position, Z1-Position, and Z2-Position, and then using the following formula:

$$R_{touch} = (R_{xplate}) * (X_{position}/4096) * [(Z2/Z1) - 1]$$

The second method is that when both the resistances of the X-plate and Y-plate are known. The resistance, Rtouch, is calculated from the results of three conversions, X-position, Y-Position, and Z1-Position, and then using the following formula:

$$R_{touch} = (R_{xplate} * X_{position}/4096) * [(4096/Z1) - 1] - R_{yplate} * [1 - (Y_{position}/4096)]$$



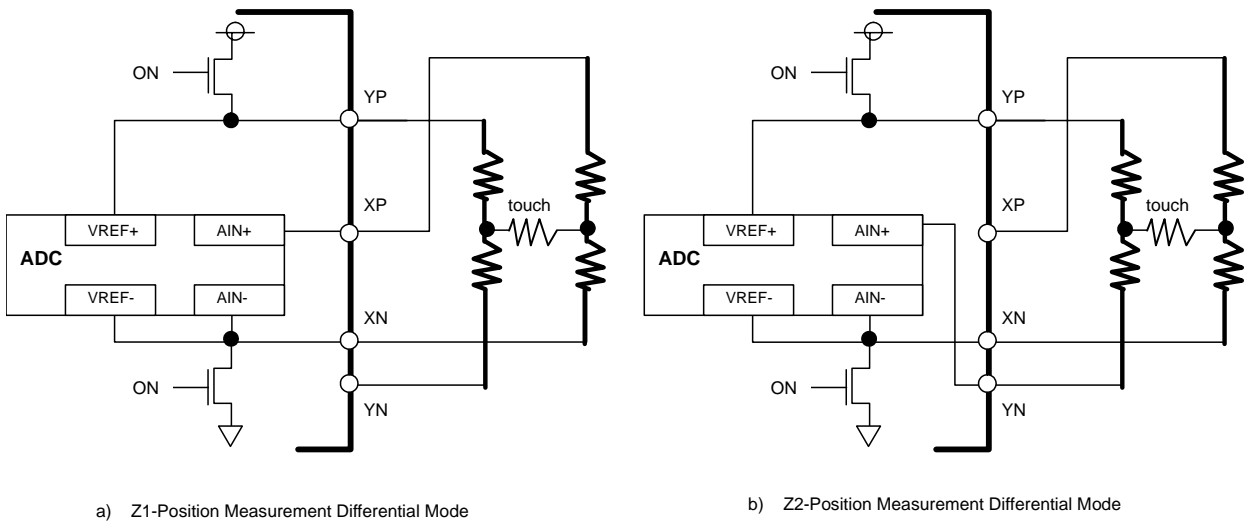

Figure 3 Pen Pressure Measurements

**■ Voltage Reference**

The AK4182A has an internal 2.5V voltage reference. This reference can be turned ON when PD1 = “1”, and OFF when PD1 = “0”. This reference is used in the single-ended mode for the battery monitoring, temperature measurement, or for auxiliary input. A 0.1μF or larger capacitor should be connected for stable operation of the VREF circuit. Settling time depends on this external capacitance, but 500μs or longer time is required if the external capacitance is 0.1μF.

If an external voltage reference is used, PD1 bit should be set to “0”.  
 VCC should be more than 2.7V in order to be stable internal output reference when PD1 = “1” (internal voltage reference).

**■ Battery Measurement**

The AK4182A can directly measure the battery voltage up to 5V while the AK4182A operates at 2.2V to 3.6V. The VBAT input voltage is divided internally by the resistance of R1 (7.5kΩ) and R2 (2.5kΩ) and applied to the input of AD converter (AIN+) as shown in Figure 4. Minimum 5μs is required as tracking time.

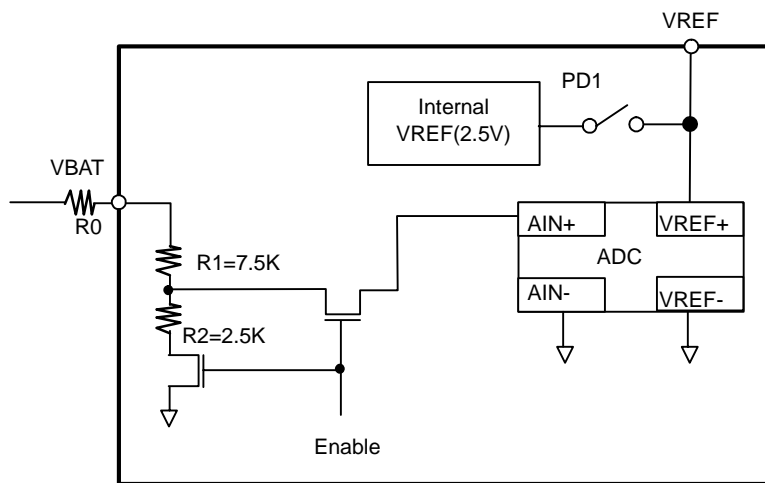

Figure 4 Battery Monitoring

■ Temperature Measurement

Equation <1> describes the forward characteristics of the diode.

$$i_D = I_0 \exp(v_D/V_T) \quad (V_T = kT/q) \quad <1>$$

$I_0$ : reverse saturation current  
 $q$  :  $1.602189 \times 10^{-19}$  (electron charge)  
 $k$  :  $1.38054 \times 10^{-23}$  (Boltzmann's constant)  
 $v_D$ : voltage across diode  
 $T$ : absolute temperature K

The diode characteristic is approximately shown as a diode junction voltage. That is theoretically proportional to the temperature; the ambient temperature can be predicted by knowing this voltage.

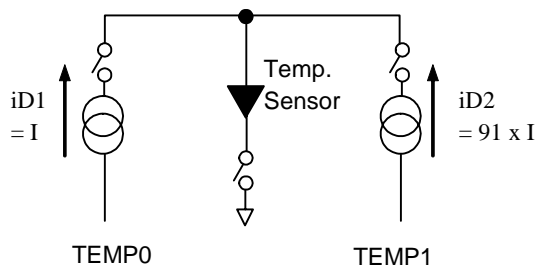

Figure 5 Temperature Measurement

As the AK4182A has two different fixed current circuits and a diode (temperature sensor), the temperature can be measured by using two different methods.

The first method needs two conversions, but can derive the temperature directly without knowing the voltage at a specific temperature.

From equation <1>

$$(i_{D2} / i_{D1}) = \exp \{ (v_{(91 \times I)} - v_{(I)}) / V_T \} \quad N = (i_{D2} / i_{D1}) = 91 \text{ (ratio of the current)}$$

$$T^{\circ}\text{C} = (\Delta V_{be} * q) / (k * \ln N) - 273$$

$$\Delta V_{be} = V (91 \times I) - V (I)$$

$$T^{\circ}\text{C} = 2.573 \times 10^3 \times \Delta V_{be} - 273$$

The second method needs only one conversion as the following equation, but requires knowing the junction voltage at the specific temperature.

$$T = (k/q) * v_D / \ln (i_D / I_0) \quad <2>$$

■ Digital I/F

The digital I/O of AK4182A can operate from 1.5V IOVDD. This allows connecting the low-voltage microprocessor. The full scale level of digital I/O voltage is specified IOVDD.

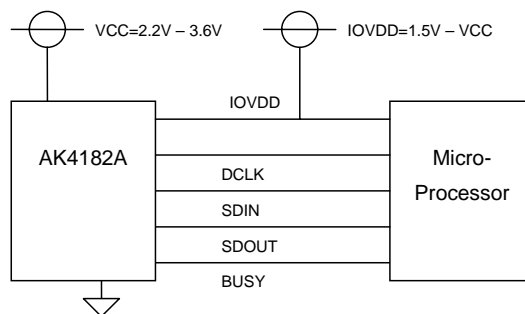

Figure6 Digital I/F

■ Control Command

The control command, 8 bits, provided to the AK4182A via DIN is shown in the following table. This command includes start bit, channel selection, resolution, measurement configuration, and power-down mode. The AK4182A latches the serial command at the rising edge of DCLK. Refer to the detailed information regarding the bit order, function, the status of driver switch, ADC input, reference voltage as shown in **Table 2**.

D7	D6	D5	D4	D3	D2	D1	D0
S	A2	A1	A0	MODE	SER/ $\overline{\text{DFR}}$	PD1	PD0

BIT	Name	Function
7	S	Start Bit. This bit must be "H" because the AK4182A initiates the command recognition
6-4	A2-A0	Channel Selection Bits. Analog inputs to the A/D converter and the activated driver switches are selected. Please see the following table for the detail.
3	MODE	Resolution of A/D converter. "L": 12 bit output "H": 8 bit output
2	SER/ $\overline{\text{DFR}}$	Measurement Mode (Single-Ended/Differential)
3	PD1-PD0	Power-down Mode (reference to "■ Power-down Control")

Control Command				Status of Driver Switch				ADC input ( $\Delta\text{AIN}$ )		Reference Voltage ( $\Delta\text{VREF}$ )		
A2	A1	A0	SER/ $\overline{\text{DFR}}$	XP	XN	YP	YN	AIN+	AIN-	VREF+	VREF-	Note
0	0	0	1	OFF	OFF	OFF	OFF	TEMP0	GND	VREF	GND	TEMP0
0	0	1	1	OFF	OFF	ON	ON	XP	GND	VREF	GND	Y-axis
0	1	0	1	OFF	OFF	OFF	OFF	VBAT	GND	VREF	GND	Battery Monitor
0	1	1	1	OFF	ON	ON	OFF	XP(Z1)	GND	VREF	GND	Z1 (Pen Pressure)
1	0	0	1	OFF	ON	ON	OFF	YN(Z2)	GND	VREF	GND	Z2 (Pen Pressure)
1	0	1	1	ON	ON	OFF	OFF	YP	GND	VREF	GND	X-axis
1	1	0	1	OFF	OFF	OFF	OFF	IN1	GND	VREF	GND	IN1
1	1	1	1	OFF	OFF	OFF	OFF	TEMP1	GND	VREF	GND	TEMP1
0	0	0	0									NA
0	0	1	0	OFF	OFF	ON	ON	XP	YN	YP	YN	Y-axis
0	1	0	0									NA
0	1	1	0	OFF	ON	ON	OFF	XP(Z1)	XN	YP	XN	Z1 (Pen Pressure)
1	0	0	0	OFF	ON	ON	OFF	YN(Z2)	XN	YP	XN	Z2 (Pen Pressure)
1	0	1	0	ON	ON	OFF	OFF	YP	XN	XP	XN	X-axis
1	1	0	0									Sleep mode
1	1	1	0									NA

Table 2 Control Command List

## ■ Power on Sequence

It is recommended that the control command is sent to fix the internal register value to be 00H when first power up. This initiates all registers such as A2-0 bit, MODE bit, SER/DFR bit, PD1 bit and PD0 bit. The sequence is that 1) Power On with CSN = "L" or "H" then CSN = "H". 2) Send control command after CSN = "L". 3) CSN = "H" again. Once sending command to fix the internal register after first power up, the state of AK4182A is held on the known-condition of state as last command issued.

## ■ Sleep mode

AK4182A supports sleep mode that enables touch panel to put open state and disables pen interrupt function. AK4182A goes into sleep mode when AK4182A gets the sleep control command. The selection of the Sleep mode is set by "MODE" bit. The state of both the output of PENIRQN pin and the connection with touch panel interface (XP, YP, XN, and YN) are the following Table 3. AK4182A goes into the sleep mode with the power-down mode set by PD1, PD0 (refer to Table 4). AK4182A keeps the sleep mode until it receives next control command.

Control command		CSN="L"		CSN="H"	
command	MODE	PENIRQN	Touch Panel	PENIRQN	Touch Panel
111010XX	1	Normal Operation	Normal Operation	Hi-z	Open
111000XX	0	Normal Operation	Normal Operation	Output "H"	Open

Table 3 Sleep Command Setting

The timing of going into the Sleep mode is the rising edge of the 8<sup>th</sup> DCLK. This sleep mode is available when CSN = "H". AK4182A goes into normal operation out of sleep mode when the normal control command receives. The initial state after power up is in a normal state.

## ■ Power-down Control

Power-down is controlled by two bits, PD0 bit and PD1 bit. The power-down state of internal voltage reference is controlled by PD1 bit, and is updated at the rising edge of 7<sup>th</sup> DCLK with CSN = "L".

The power-down state of A/D converter, and touch screen driver switches is controlled by PD0 bit, and is updated at the rising edge of 8<sup>th</sup> DCLK with CSN = "L".

If PD0 bit is set to "1", the state of the driver switches is maintained until the 5<sup>th</sup> DCLK $\uparrow$  of the next conversion if CSN is "L". If CSN is "H", all driver switches except for YN switch switches are turned off and are open states. Only YN driver switch is turned ON and YN pin is forced to the ground in this case.

PD1	PD0	PENIRQN	Function
0	0	Enabled	Auto Power-down Mode. A/D converter is automatically powered up at the start of the conversion, and goes to power-down state automatically at the end of the conversion. And the AK4182A is always powered down at this mode if CSN= "H". All touch screen driver switches except for YN switch are turned off and relative pins are open state. Only YN driver switch is turned ON and YN pin is forced to the ground in this case. PEN interrupt function is enabled except for the tracking time and conversion time even CSN= "L". Please see "■ PEN Interrupt" for the detail. The internal voltage reference is always power-down state.
0	1	Enabled	ADC ON Mode A/D converter is always powered up while CSN = "L". The internal voltage reference is always power-down state. If X-axis or Y-axis is selected as analog input, touch screen driver switches are always turned ON and the current flows through the touch plate if CSN= "L". This is effective if more settling time is required to suppress the electrical bouncing of touch plate.
1	0	Enabled	VREF ON Mode The internal voltage reference is always powered up regardless of CSN state. ADC is auto power-down mode. PEN interrupt function is enabled at all the period except for the period from the 5DCLK $\downarrow$ to 20DCLK $\downarrow$ regardless of CSN state.
1	1	Disabled	ADC and VREF ON Mode A/D converter and the internal voltage reference is power-up state PEN interrupt function is disabled and PENIRQN is forced to "H" state if CSN= "H". The behavior of PENIRQN is the same as "ADC ON Mode"

Table 4 Power-down Control

■ Serial Interface

The AK4182A is controlled via 4-wire serial interface, CSN, DCLK, DIN, DOUT. Please see “■ Switching Characteristics” for the detail.

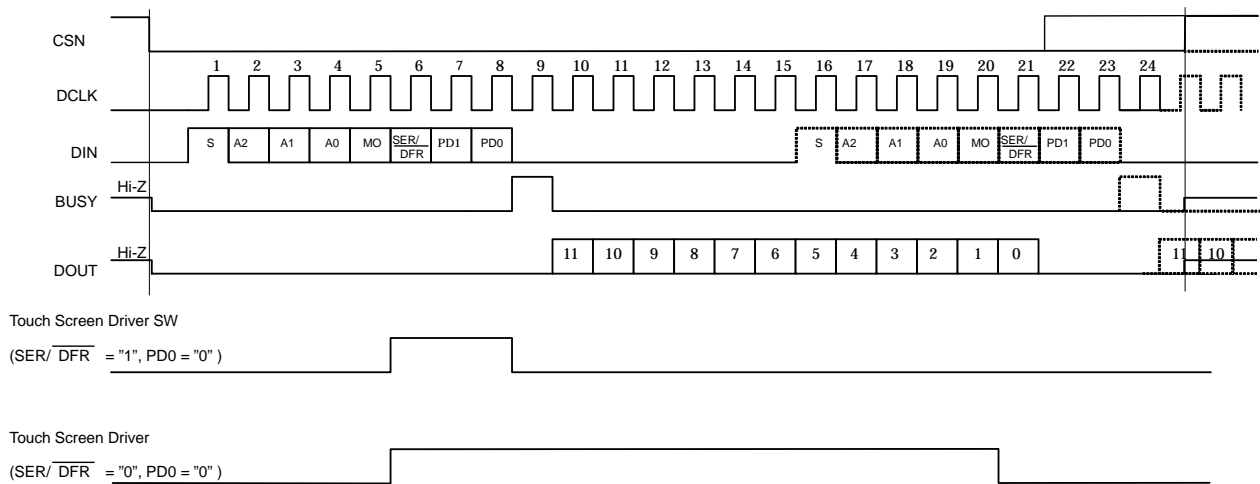

Figure 7 Serial Interface

BUSY and DOUT goes to “L” from Hi-Z state at the falling edge of CSN. The AK4182A latches the 8bit control word serially via DIN at the rising edge of DCLK. As the AK4182A starts the command decoding at the first “H” bit after CSN= “↓”, MSB (S bit) of the command must be “H”.

Tracking time is the period from the falling edge of 5th DCLK to the falling edge of 8th DCLK. If  $\overline{\text{SER/DFR}} = \text{“1”}$ ,  $\text{PD0} = \text{“0”}$ , and if analog input is X-axis or Y-axis (the measurement is the pen position or pen pressure), the touch screen driver switches are turned ON for this 3DCLK period. If  $\overline{\text{SER/DFR}} = \text{“0”}$ , the switches are turned ON for the period from 5DCLK↓ to 20 DCLK↓.

BUSY is “H” for one DCLK period, which is from 8DCLK↓ to 9DCLK↓. BUSY is “L” for other period. The AK4182A outputs A/D data with MSB first via DOUT from the falling edge of 9th DCLK. DIN must keep low state for minimum 7 DCLK times (9th-15th DCLK) after command is sent on the DIN.

The AK4182A can output one A/D data per 15 DCLK clock cycles for the fastest way as shown in the dotted line of the Figure 7.

■ Pen Interrupt

The AK4182A has pen interrupt function to detect the pen touch. Pen interrupt function is enabled at power-down state. YN pin is connected to GND at the PEN interrupt enabled state. And XP pin is pulled up via an internal resistor (Ri), typically 50kΩ. If touch plate is pressed by pen, the current flows via <VCC> - <Ri> - <XP> - <the plates> - <YN>- <GND>. The resistance of the plate is generally 1K Ω or less, PENIRQN is forced to “L” level. If the pen is released, PENIRQN returns “H” level because two plates are disconnected, and the current doesn’t flow via two plates.

If the plate is touched with pen or finger, PENIRQN goes to “L” at CSN = “H” unless previous command issued with both PD1 and PD0 is “1”. PENIRQN is disabled and keeps “H” level regardless of the touched/non-touched state if CSN = “H”.

The operation of PENIRQN is related to PD0 bit. PD0 bit is updated at the rising edge of 8th DCLK (please see “■ Power-down Control” for the detail). Therefore, the last PD0 bit is valid until this timing. (The internal voltage reference is controlled by only PD1 bit regardless of PD0 bit and CSN state.)

i. The period from CSN↓ to the 5th DCLK.

The behavior of PENIRQN is related to the combination of the last selected analog input channel, and the last PD0 bit. If the last PD0 bit was set to “0”, PENIRQN is “H” while the plate is not pressed and “L” while the plate is pressed regardless of the last analog input. If the last PD0 bit was set to “1”, the last analog input decides the level of PENIRQN. If the last analog input channel is ether X-axis or Y-axis, PENIRQN is “L” for all the time in this period regardless of the touched/non-touched state. On the other hand, if the last analog input is temperature, VBAT, or auxiliary inputs, PENIRQN is “H” for all the time in this period regardless of the touched/non-touched state.

ii. The period from the 5th DCLK↓ to the 20th DCLK↓ on CSN = “L”

The behavior of PENIRQN is related to the selected analog input. If the X-axis or Y-axis is selected as analog input, PENIRQN is forced to “L” regardless of the touched/non-touched state. If the temperature, VBAT, or auxiliary inputs is selected, PENIRQN is forced to “H” regardless of the touched/non-touched state.

iii. The period from the 20th DCLK↓ to CSN↑

The behavior of PENIRQN is related to the combination of the current selected analog input channel, and the current PD0 bit. If the current PD0 bit is set to “0”, PENIRQN is “H” while the plate is not pressed and “L” while the plate is pressed regardless of the current selected analog input. If the current PD0 bit is set to “1”, the current analog input decides the operation of PENIRQN. If the current analog input channel is ether X-axis or Y-axis, PENIRQN is “L” for all the time in this period regardless of the touched/non-touched state. On the other hand, if the current analog input is temperature, VBAT, or auxiliary inputs, PENIRQN is “H” for all the time in this period regardless of the touched/non-touched state.

It is recommended that the micro controller mask the pseudo-interrupts while the control command is issued or A/D data is output.

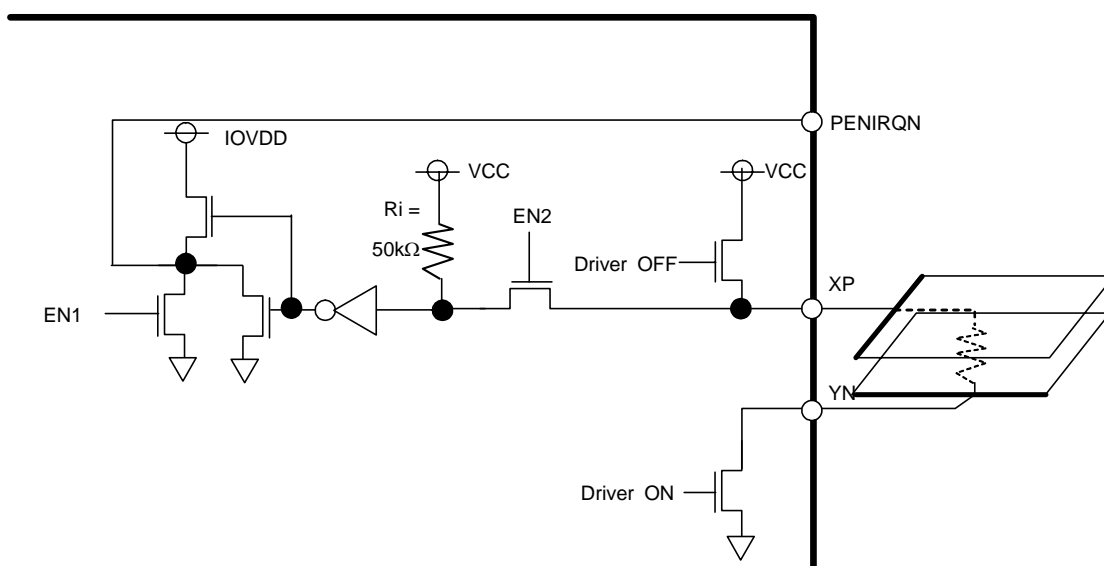
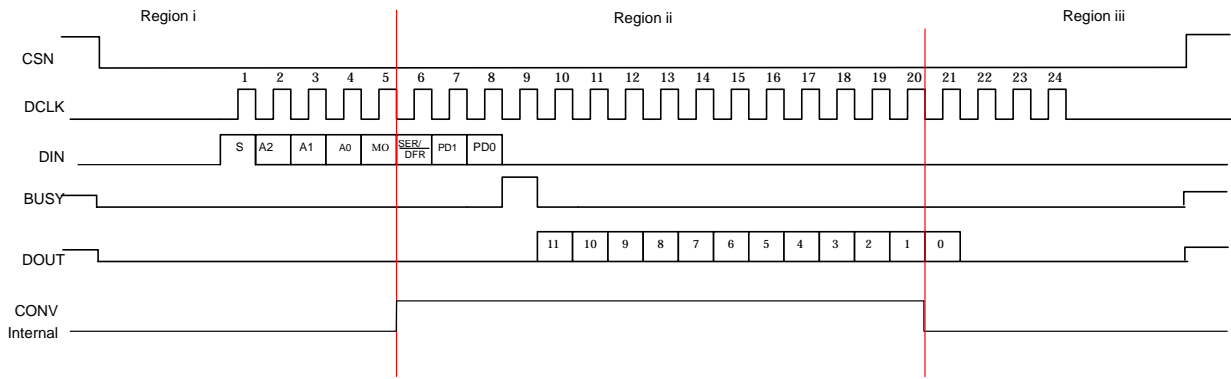

Figure 8 PENIRQ Functional Block Diagram



```

AXIS = ((!A2) & (!A1) & (A0))      /* X-axis Measurement */
        | ((!A2) & (A1) & (A0))    /* Z1 Measurement */
        | ((A2) & (!A1) & (!A0))    /* Z2 Measurement */
        | ((A2) & (!A1) & (A0));    /* Y-axis Measurement */

EN1 = ((!CSN) & (!CONV) & AXIS & PD0)
        /* CSN="L", X/Y/Z1/Z2 Measurement, PD0 = 1, NOT "CONV period" */
        | ((!CSN) & AXIS & CONV);
        /* CSN="L", X/Y/Z1/Z2 Measurement, "CONV period" */

EN2 = ((!CSN) & (!CONV) & (!PD0))
        /* CSN="L", PD0 = 1, NOT "CONV period" */
        | (CSN & (!(PD1 & PD0)));
        /* CSN="H", (PD0, PD1) is not (1,1) */
    
```

**Package**

16pin QFN (Unit: mm)

TOP VIEW

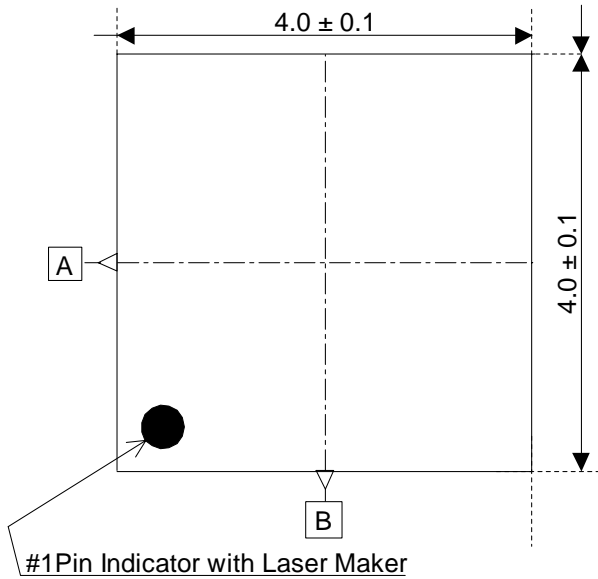

BOTTOM VIEW

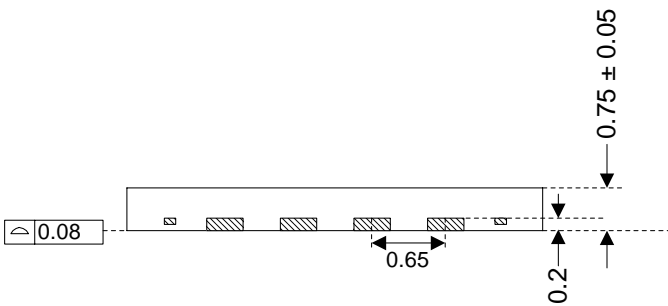
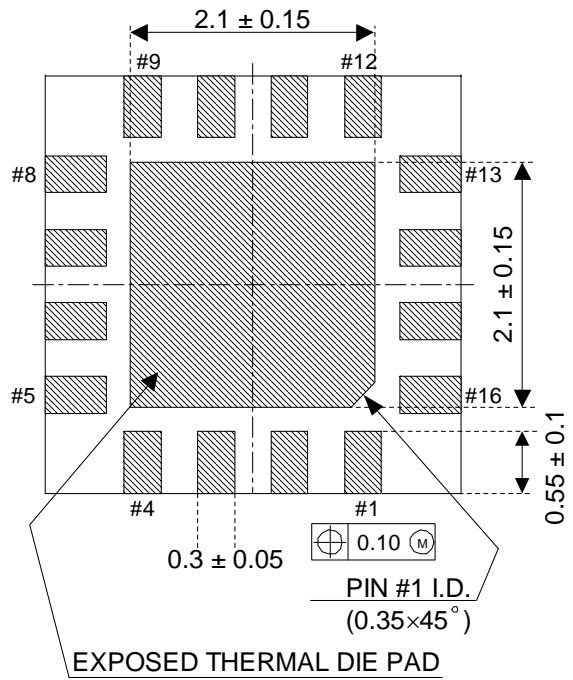

Note: The thermal die pad is tied to PCB substrate (GND).

■ **Package & Lead frame material**

Package molding compound: Epoxy

Lead frame material: Cu

Lead frame surface treatment: Solder (Pb free) plate



**Marking**

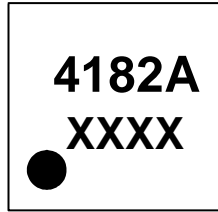

1

XXXX: Date code identifier (4 digits)

## IMPORTANT NOTICE

- These products and their specifications are subject to change without notice. Before considering any use or application, consult the Asahi Kasei Microsystems Co., Ltd. (AKM) sales office or authorized distributor concerning their current status.
- AKM assumes no liability for infringement of any patent, intellectual property, or other right in the application or use of any information contained herein.
- Any export of these products, or devices or systems containing them, may require an export license or other official approval under the law and regulations of the country of export pertaining to customs and tariffs, currency exchange, or strategic materials.
- AKM products are neither intended nor authorized for use as critical components in any safety, life support, or other hazard related device or system, and AKM assumes no responsibility relating to any such use, except with the express written consent of the Representative Director of AKM. As used here:
  - (a) A hazard related device or system is one designed or intended for life support or maintenance of safety or for applications in medicine, aerospace, nuclear energy, or other fields, in which its failure to function or perform may reasonably be expected to result in loss of life or in significant injury or damage to person or property.
  - (b) A critical component is one whose failure to function or perform may reasonably be expected to result, whether directly or indirectly, in the loss of the safety or effectiveness of the device or system containing it, and which must therefore meet very high standards of performance and reliability.
- It is the responsibility of the buyer or distributor of an AKM product who distributes, disposes of, or otherwise places the product with a third party to notify that party in advance of the above content and conditions, and the buyer or distributor agrees to assume any and all responsibility and liability for and hold AKM harmless from any and all claims arising from the use of said product in the absence of such notification.