

VSC7983

VITESSE

11.2 Gb/s Electroabsorption Modulator Driver



FEATURES:

- ▶ Single +5V or -5.2V Supply
- ▶ Selectable Data Retiming
- ▶ AC-Coupled Inputs
- ▶ Internally-Stabilized Modulation and Bias Outputs
- ▶ Excellent Output Return Loss
- ▶ 300mV Differential Data Input Sensitivity
- ▶ Programmable Output Data Eye Crossing Point
- ▶ Available in Bare Dice, 32-pin 5mm x 5mm QFN, or 32-pin Metal-glass QFP

APPLICATIONS:

- ▶ 10G Transmit Optical Sub-Assemblies
 - 9.983 Gb/s SONET OC-192/SDH STM-64
 - 10.3 Gb/s Ethernet
 - 10.5 Gb/s Fibre Channel
 - 10.7 Gb/s OTN G.709/G.975
 - 12.5 Gb/s SONET with FEC Optical
 - DWDM SONET/SDH
- ▶ Transponders
 - XENPAK, X2, XPAK modules
 - 300pin MSA modules
- ▶ Transceivers
 - XFP modules

BENEFITS:

- ▶ Unique architecture provides excellent output impedance, further reducing output jitter.
- ▶ Extended case temperature range (-10°C to 95°C) providing more thermal margin for system design.
- ▶ Guaranteed operation at worst-case duty cycle (85% crossing point), improving yield by enabling the use of a wider range of modulators.
- ▶ Internal operational amplifiers reduce off-chip circuit complexity and component count.

SPECIFICATIONS:

- ▶ VSC7983
 - Supply Voltage: +5V or -5.2V
 - Supply Current: 277mA
 - Power Dissipation: 1440mA
 - Input Sensitivity: 300mV to 1V Single Ended or Differential
 - Data Rate: 11.2 Gb/s
 - Clock Rate: 11.2GHz
 - Output Offset Adjust: 0 to 1V
 - Output Modulation Voltage: 2 to 3V
 - Output Rise Fall Time: 28 ps
 - Data Eye Crossing Point Adjustment: 25% to 85%
 - Operating Temperature from -10°C to 95°C
 - Package:
 - VSC7983-W: Dice
 - VSC7983YE-02: 32-pin 5mm x 5mm QFN
 - VSC7983CD: 32-pin Metal-glass QFP

BLOCK DIAGRAM:

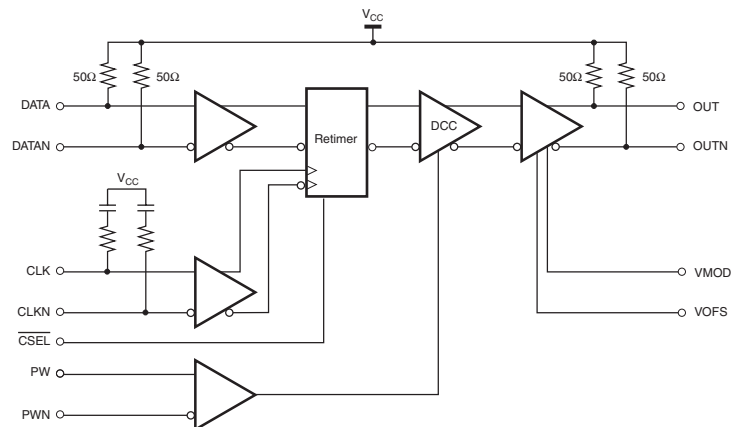

11.2 Gb/s Electroabsorption Modulator Driver

GENERAL DESCRIPTION:



The VSC7983 is a 11.2Gb/s electroabsorption modulator driver for SONET/SDH and 10GbE applications. The device provides selectable data retiming to improve jitter performance and controls for output bias voltage, modulation voltage, and duty cycle. Internal operational amplifiers preclude the need for

additional off-chip circuitry. The unique architecture of the VSC7983 provides excellent output impedance which improves the match between the driver and load, further reducing output jitter. The VSC7983 is available in a 32-pin MicroLeadFrame™ (MLF) package, a high performance 32-pin metal-glass QFP package, or in die form.

APPLICATION DIAGRAMS:

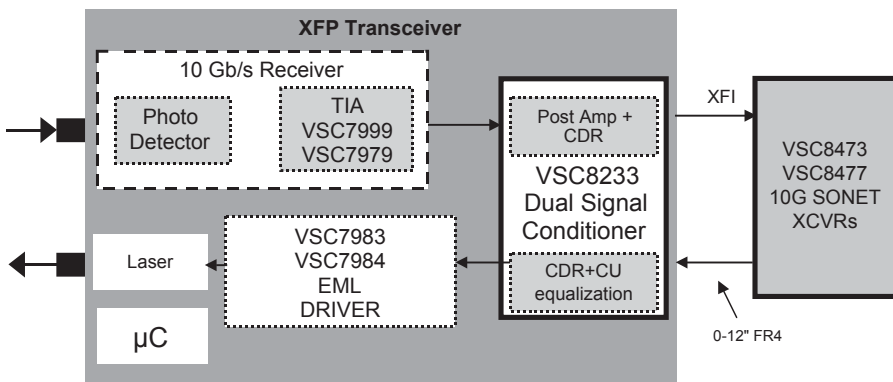
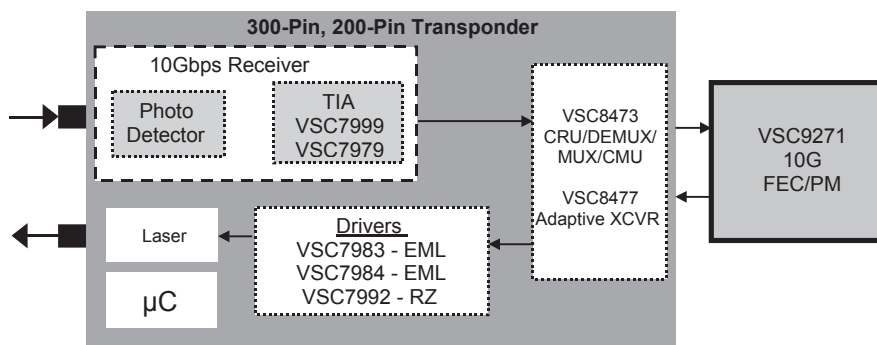

OPTICAL EYE DIAGRAMS:

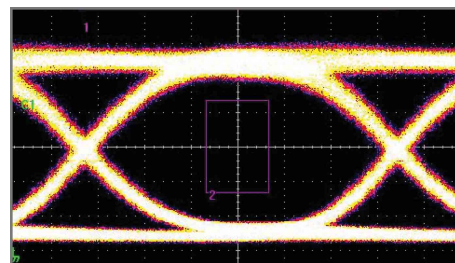
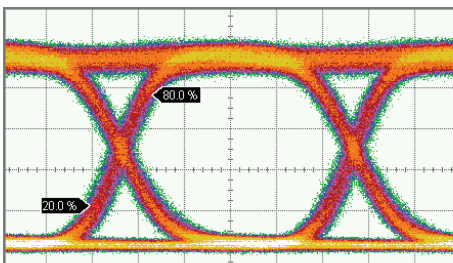

For more information on Vitesse Products visit the Vitesse web site at www.vitesse.com or contact Vitesse Sales at (800) VITESSE or sales@vitesse.com

VITESSE

741 Calle Plano
Camarillo, CA 93012, USA
Tel: +1 805.388.3700
Fax: +1 805.987.5896
www.vitesse.com