

VSC7148

VITESSE

16-Port JBOD Loop Chip for 1.0625 Gb/s FC-AL Storage Applications



APPLICATIONS:

- ▶ 1.0625 Gb/s FC-AL JBODs

FEATURES:

- ▶ All the Functionality Needed to Implement a Complete Daisy-Chainable 16-drive 1 Gb/s FC-AL JBOD Subsystem
- ▶ Two Host Ports with Two Pairs of FibreTimer™ Clock Recovery Units (CRUs) Configurable as Either Repeaters or Retimers
- ▶ Sixteen Port Bypass Circuits (PBC) for Drive Control
- ▶ Sixteen PBC Internal Snoop Loop™ for Loop Diagnostics
- ▶ Configurable as Either a Single 16-drive Loop or Two 8-drive Loops
- ▶ I²C Interface for Configuration/Status/Control
- ▶ Seamless Interface to Enclosure Management Chipsets such as the Vitesse SSC100/VSC120/VSC055 for Managed JBOD Applications

SPECIFICATIONS:

- ▶ On-chip terminators selectable as 100/150 ohm
- ▶ 3.3V Power Supply, 4.3 W
- ▶ 256-pin, 27mm Thermally Enhanced BGA

BLOCK DIAGRAM:

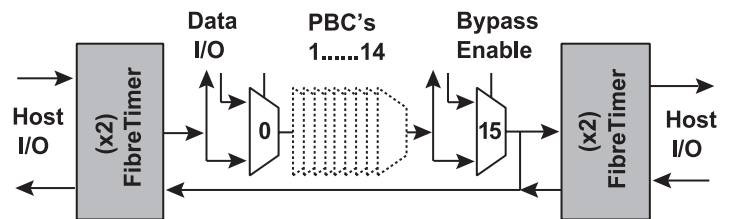

GENERAL DESCRIPTION:



The VSC7148 is typically used to distribute Fibre Channel signals to an array of disk drives in managed and un-managed arrays. The use of an I²C Interface allows access to status information and control of configuration through an easily-implemented, industry-standard, protocol.

The VSC7148 easily interfaces with the SSC100 or VSC120 Enclosure Management Controllers to offer unsurpassed diagnostic capability within the industry. The SSC100 (or VSC120) communicates with the VSC7148 through the I²C interface to provide complete loop status, configuration, and diagnostic control to the host. In this configuration, up to fifteen drives on a single loop may be accessed with a single Fibre Channel connector. Serial data from the loop enters the FC-AL port of the SSC100 where the data is processed, returned to the loop, and handed to the VSC7148 for drive communications. In addition, the VSC7148 is the only device on the market that supports two loops within a single device. The External Loop may be configured for all Fibre Channel data traffic while the Snoop

Loop may be used for monitoring or isolating specific ports for diagnostics. With this architecture, a design engineer has the flexibility to offer full Fibre Channel support on the External Loop while isolating error conditions and performing loop diagnostics on the Snoop Loop. When coupled with the SSC100's initiator features, the VSC7148 can provide fault isolation conditions and JBOD quality characteristics back to the host in realtime. When used in a managed JBOD application, the VSC7148/SSC100 chipset allows fault isolation down to the lowest Field Replaceable Unit (FRU) to reduce downtime and support costs, and lead to higher availability.

SOFTWARE:

The VSC7148 is supported by an API within our enclosure management Software Development Kit (SDK). The SDK includes software to implement a FC transport and SES diagnostic environment. In addition, the SDK also includes a System Services module which provides APIs to the peripheral functionality (interrupts, timers etc.) in the Enclosure Management Controller. The System Services also includes driver libraries for popular I²C devices such as National's LM75, LM78, and many others.

APPLICATION DIAGRAM:

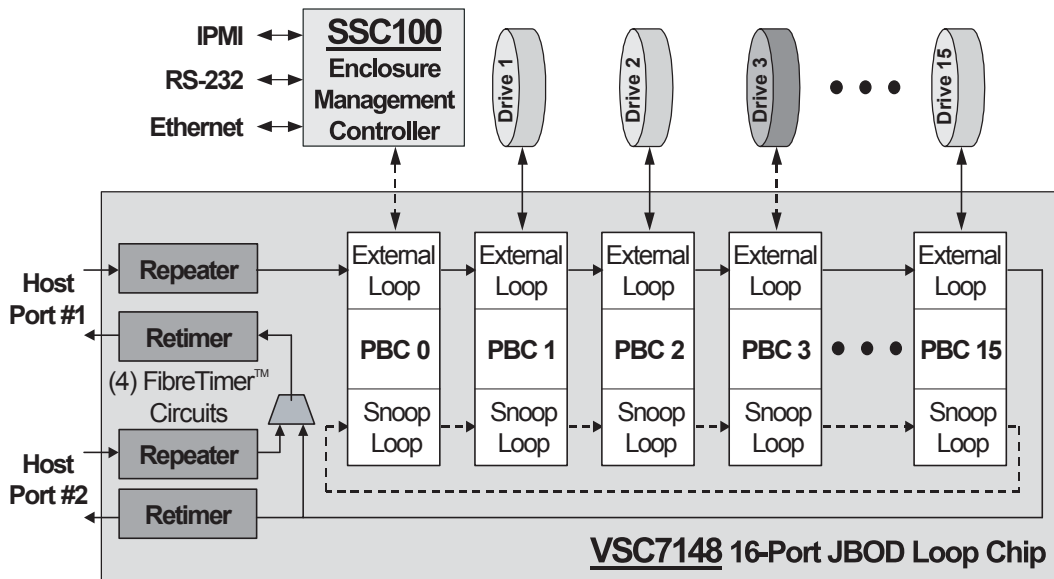

For more information on Vitesse Products visit the Vitesse web site at www.vitesse.com or contact Vitesse Sales at (800) VITESSE or sales@vitesse.com