

TOSHIBA Bipolar Linear Integrated Circuit Silicon Monolithic

TA7288P

Sequential Dual-Bridge Driver (Driver for Switching between Forward and Reverse Rotation) for DC Motor

The TA7288P is a bridge driver that is ideal for normal / reverse switching.

This circuit offers four modes: normal rotation, reverse rotation, stop, and brake.

The output current is 1.0 A (AVE.) and 2.0 A (PEAK). TA7288P has an ideal circuit configuration for VCR front tape loading and offers two types of power supply pins. One is for output, the other for control. The V_{ref} pin on the output side used to control the motor voltage facilitates motor voltage adjustment. The IC requires little input current, enabling direct connection with CMOS.

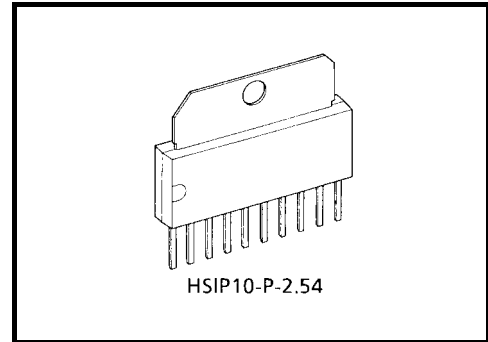

Weight: 2.47 g (typ.)

Features

- Wide range of operating voltage: V_{CC} (opr.) = 4.5 to 18 V
 V_S (opr.) = 0 to 18 V
 V_{ref} (opr.) = 0 to 18 V
 No malfunction occurs even if V_{CC} is higher than V_S or vice versa. however, observe $V_{ref} \leq V_S$.
- Output current up to 1.0 A (AVE.) and 2.0 A (PEAK)
- Built-in thermal shutdown circuit and overcurrent protection circuit for output pins
- Built-in punch-through current restriction circuit
- Built-in back electromotive force absorber diode
- Built-in hysteresis circuit

The TA7288P:

The TA7288P is Sn plated product including Pb.

The following conditions apply to solderability:

*Solderability

1. Use of Sn-37Pb solder bath
 - *solder bath temperature = 230°C
 - *dipping time = 5 seconds
 - *number of times = once
 - *use of R-type flux
2. Use of Sn-3.0Ag-0.5Cu solder bath
 - *solder bath temperature = 245°C
 - *dipping time = 5 seconds
 - *the number of times = once
 - *use of R-type flux

Block Diagram

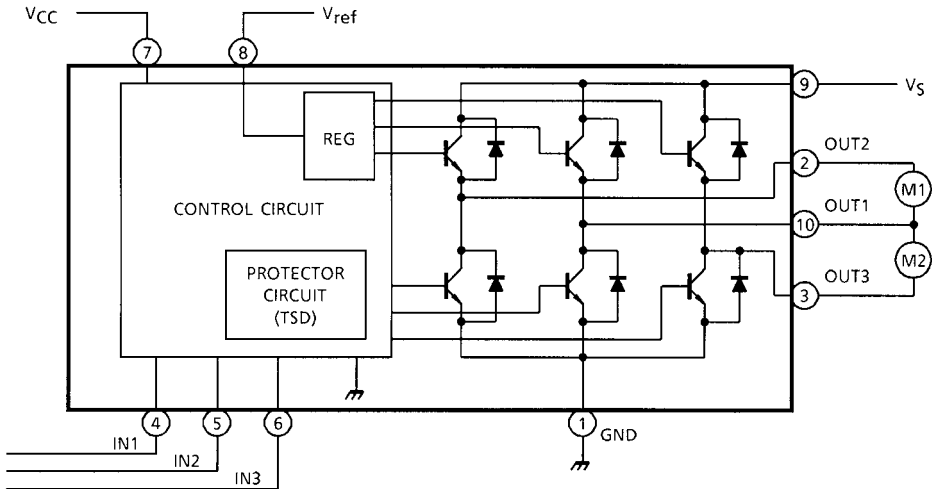

Pin Function

Pin No.	Symbol	Functional Description
1	GND	GND terminal
2	OUT2	Output terminal
3	OUT3	Output terminal
4	IN1	Input terminal
5	IN2	Input terminal
6	IN3	Input terminal
7	V _{CC}	Supply voltage terminal for Logic
8	V _{ref}	Supply voltage terminal for control
9	V _S	Supply voltage terminal for Motor drive
10	OUT1	Output terminal

Input Circuit

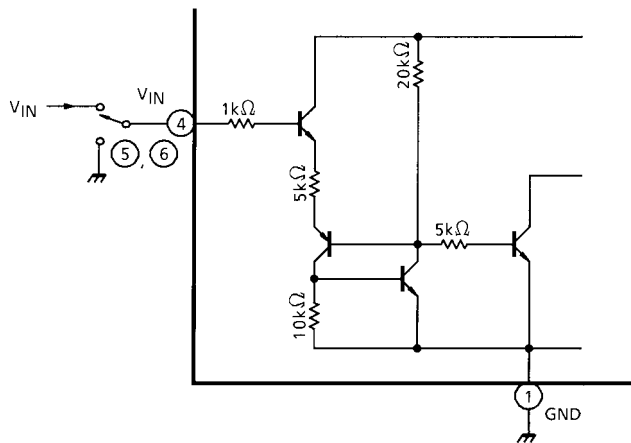

The input circuit uses active-high logic as shown below.

The specified voltage V_{IN} (H) and higher represent a logical high level. V_{IN} (L) and lower including a connection to a ground represent a logical low level.

When the input is on a logical high level, the input current I_{IN} flows into the input. So, be careful about the output impedance of the preceding stage.

Output Circuit

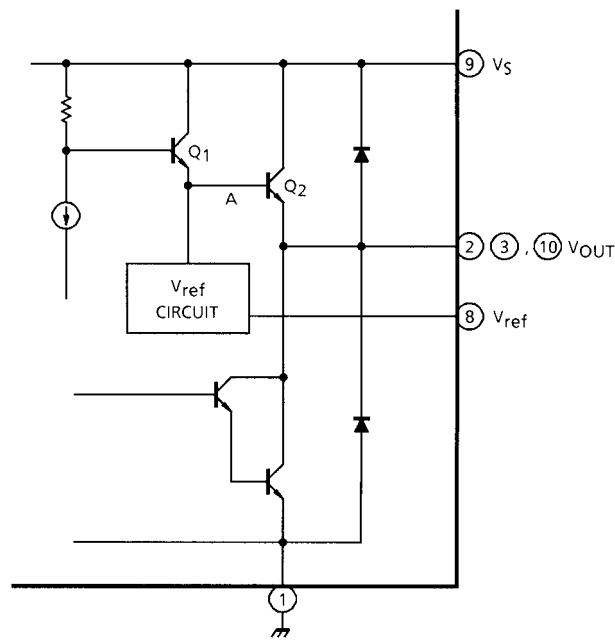

Output “H” Voltage

- Operation by V_{ref} voltage

Voltage, which is applied to V_{ref} , of which high output, $2V_{BE}$ is applied to base A of the Q_2 (power transistor) and low voltage, Q_2V_{BE} is output as V_{OUT} (H) by the V_{ref} circuit.

$$V_{OUT} = V_{ref} + 2V_{BE} - Q_2V_{BE}$$

$$V_{ref} + 0.7 (V)$$

- V_{ref}

V_{ref} terminal required to connect to V_S terminal for stable operation in case of no requirement of V_{OUT} control.

Function

Input			Output			Mode	
IN1	IN2	IN3	OUT1	OUT2	OUT3	M1	M2
0	0	1/0				STOP	STOP
1	0	0	H	L		CW/CCW	STOP
1	0	1	L	H		CCW/CW	STOP
0	1	0	H		L	STOP	CW/CCW
0	1	1	L		H	STOP	CCW/CW
1	1	1/0	L	L	L	BRAKE	BRAKE

∞: High impedance

Note: Inputs are all high active type.

Absolute Maximum Ratings (Ta = 25°C)

Characteristics		Symbol	Rating	Unit
Supply voltage		V _{CC}	25	V
Motor drive voltage		V _S	25	V
Reference voltage		V _{ref}	25	V
Output current	PEAK	I _O (PEAK)	2.0 (Note 1)	A
	AVE.	I _O (AVE.)	1.0	A
Power dissipation		P _D	12.5 (Note 2)	W
Operating temperature		T _{opr}	-30 to 75	°C
Storage temperature		T _{stg}	-5 to 150	°C

Note 1: Duty 1/10, 100 ms

Note 2: T_c = 25°C

Electrical Characteristics

(unless otherwise noted, Ta = 25°C, V_{CC} = 12 V, V_S = 18 V)

Characteristics		Symbol	Test Circuit	Test Condition	Min	Typ.	Max	Unit
Supply current		I _{CC1}	1	Output OFF CW/CCW mode	—	17	30	mA
		I _{CC2}	1	Output OFF Brake mode	—	13	25	
Input voltage	1 (High)	V _{IN} (H)	2	T _j = 25°C pin (4), (5), (6)	3.5	—	5.5	V
	2 (Low)	V _{IN} (L)	2	T _j = 25°C pin (4), (5), (6)	GND	—	0.8	
Input current		I _{IN}	2	V _{IN} = 3.5 V, sink mode	—	5	20	μA
Input hysteresis voltage		ΔV _T	2	—	—	0.7	—	V
Saturation voltage	Upper	V _{SATU-1}	3	V _{ref} = V _S , V _S -V _{out} , I _O = 0.2 A	—	0.9	1.2	V
	Lower	V _{SATL-1}	3	V _{ref} = V _S , V _{out} -GND, I _O = 0.2 A	—	1.0	1.3	V
	Upper	V _{SATU-2}	3	V _{ref} = V _S , V _S -V _{out} , I _O = 1.0 A	—	1.3	1.6	V
	Lower	V _{SATL-2}	3	V _{ref} = V _S , V _{out} -GND, I _O = 1.0 A	—	1.8	2.5	V
Output voltage		V _{SATU-1'}	3	V _{ref} = 10 V, V _{out} -GND, I _O = 0.5 A	10.7	11.0	11.8	V
		V _{SATU-2'}	3	V _{ref} = 10 V, V _{out} -GND, I _O = 1.0 A	10.4	10.7	11.5	V
Leakage current	Upper	I _L U	—	V _S = 25 V	—	—	50	μA
	Lower	I _L L	—	V _S = 25 V	—	—	50	
Diode forward voltage	Upper	V _F U	4	I _F = 1 A	—	2.2	—	V
	Lower	V _F L	4	I _F = 1 A	—	1.4	—	
Reference current		I _{ref}	2	V _{ref} = 10 V, source mode	—	5	30	μA

Test Circuit 1
I_{CC}1, 2

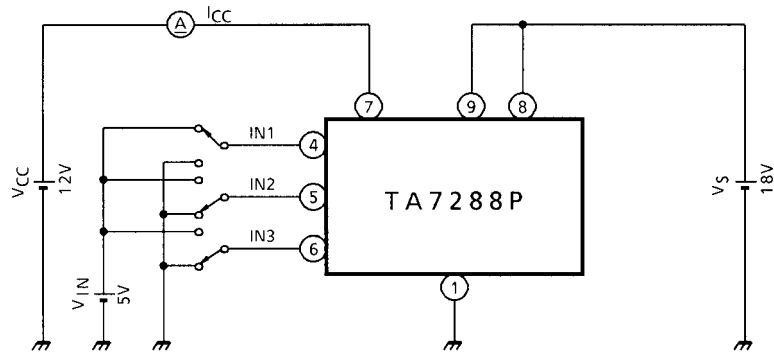

Test Circuit 2
V_{IN}(H), V_{IN}(L), I_{IN}, ΔV_T, I_{ref}

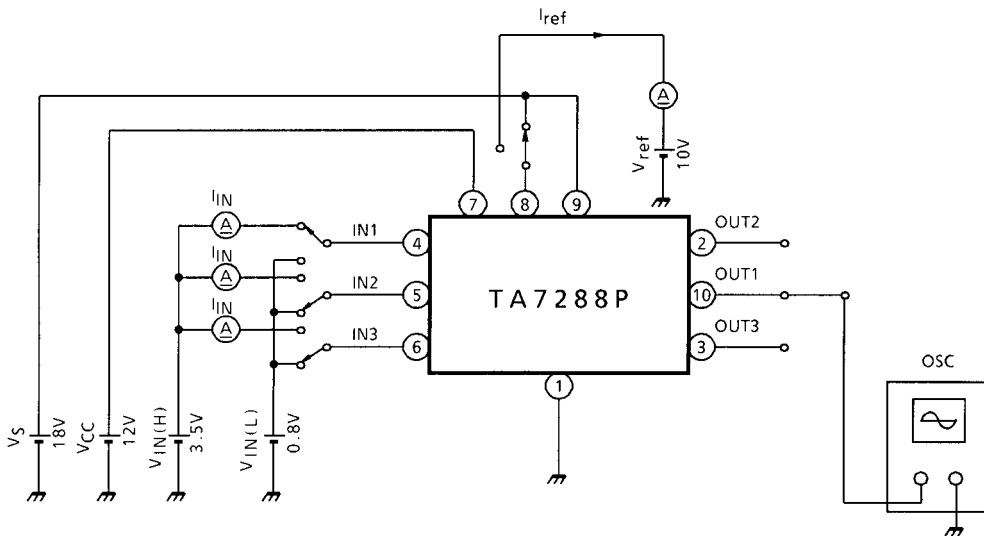

Test Circuit 3

$V_{SAT U-1, L-1, U-2, L-2, U-1', U-2'}$

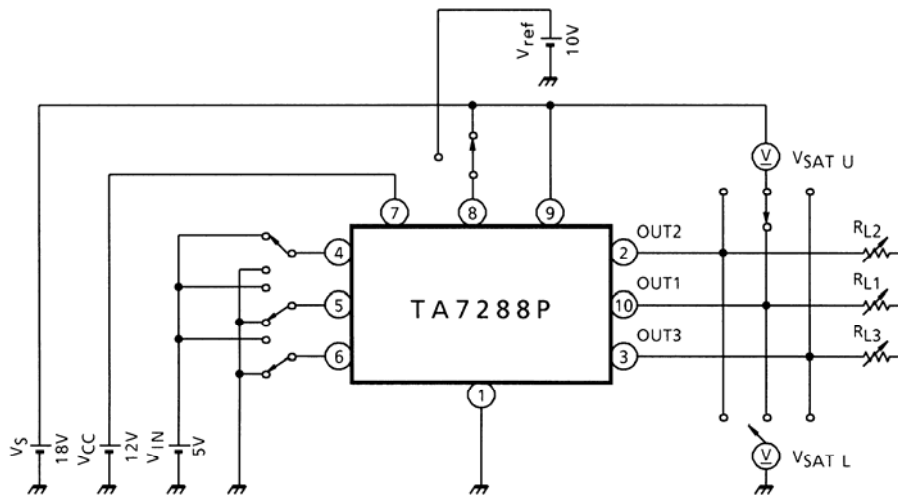

Please adjust R_{L1}, R_{L2}, R_{L3} to be output, $I_{OUT} = 0.24$ or 1.0 A.

Test Circuit 4

$V_{FU, L}$

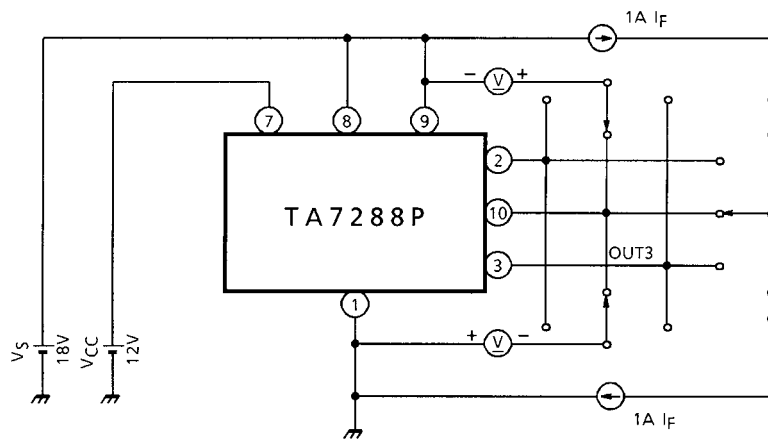

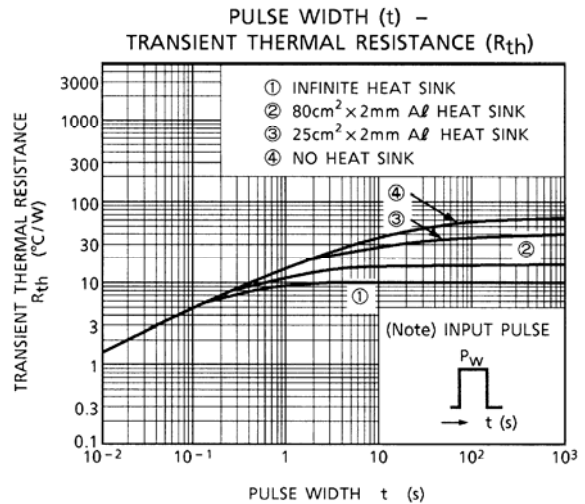
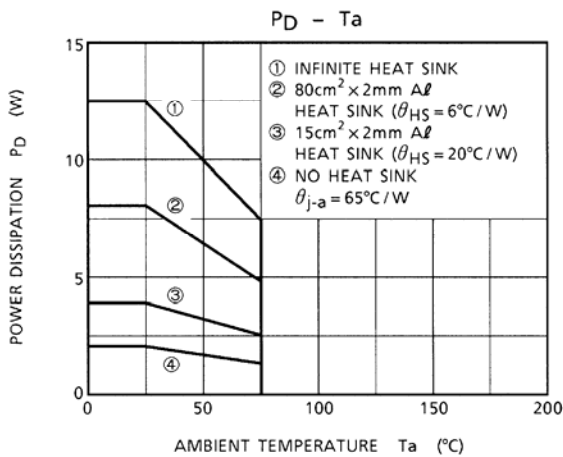

Application Circuit

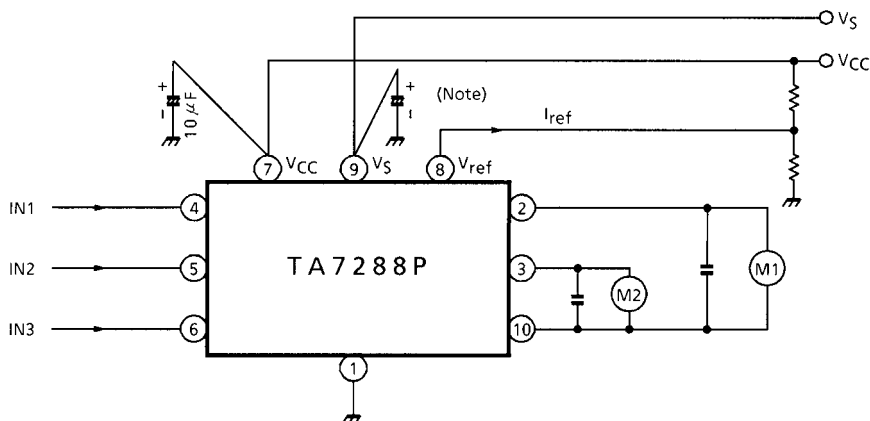

Note 1: Select an optimum value for the capacitor by experiment.

Note 2: Utmost care is necessary in the design of the output, V_{CC} , V_M , and GND lines since the IC may be destroyed by short-circuiting between outputs, air contamination faults, or faults due to improper grounding, or by short-circuiting between contiguous pins.

Note 3: When turning on the power for the ICs, apply V_S after V_{CC} (or V_{CC} and V_S simultaneously). When shutting off the power, drop V_S before V_{CC} (or V_S and V_{CC} simultaneously).
 When turning on the power (V_{CC}), keep both the inputs (IN1 and IN2) on a low level.

Package Dimensions

HSIP10-P-2.54

Unit : mm

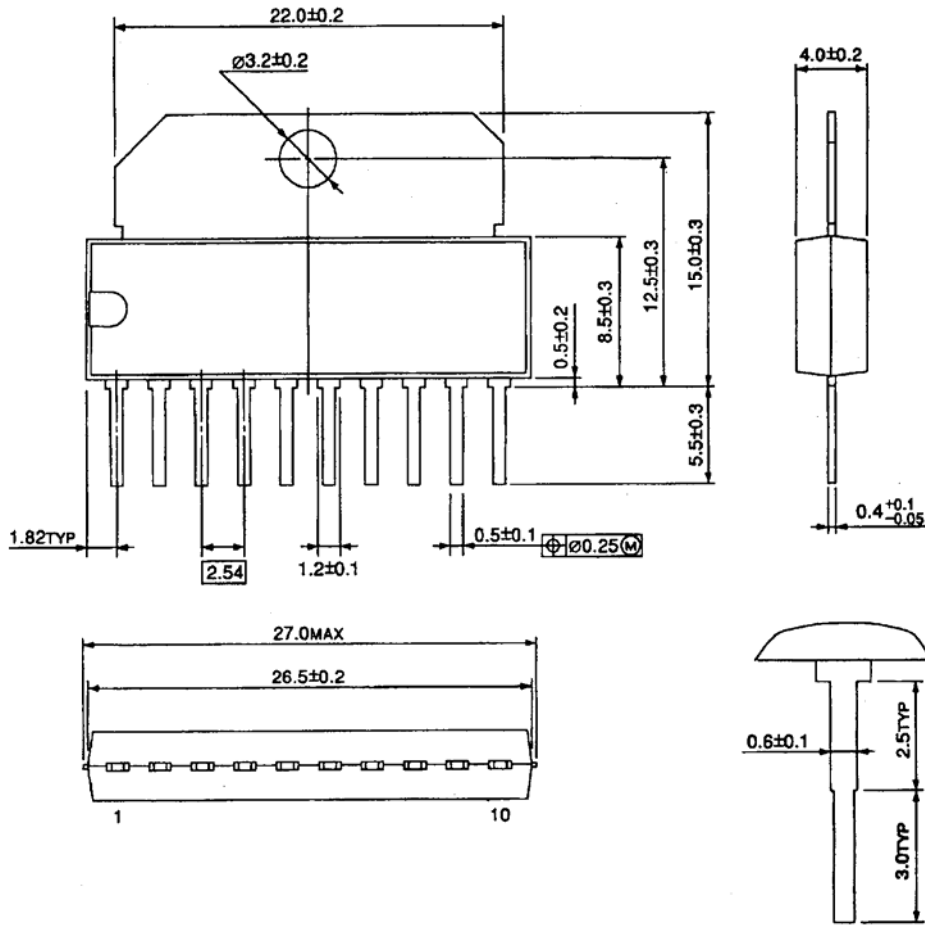

Weight: 2.47 g (typ.)

Notes on Contents

1. Block Diagrams

Some of the functional blocks, circuits, or constants in the block diagram may be omitted or simplified for explanatory purposes.

2. Equivalent Circuits

The equivalent circuit diagrams may be simplified or some parts of them may be omitted for explanatory purposes.

3. Timing Charts

Timing charts may be simplified for explanatory purposes.

4. Application Circuits

The application circuits shown in this document are provided for reference purposes only. Thorough evaluation is required, especially at the mass production design stage.

Toshiba does not grant any license to any industrial property rights by providing these examples of application circuits.

5. Test Circuits

Components in the test circuits are used only to obtain and confirm the device characteristics. These components and circuits are not guaranteed to prevent malfunction or failure from occurring in the application equipment.

IC Usage Considerations

Notes on handling of ICs

- [1] The absolute maximum ratings of a semiconductor device are a set of ratings that must not be exceeded, even for a moment. Do not exceed any of these ratings.
Exceeding the rating(s) may cause the device breakdown, damage or deterioration, and may result injury by explosion or combustion.
- [2] Use an appropriate power supply fuse to ensure that a large current does not continuously flow in case of over current and/or IC failure. The IC will fully break down when used under conditions that exceed its absolute maximum ratings, when the wiring is routed improperly or when an abnormal pulse noise occurs from the wiring or load, causing a large current to continuously flow and the breakdown can lead smoke or ignition. To minimize the effects of the flow of a large current in case of breakdown, appropriate settings, such as fuse capacity, fusing time and insertion circuit location, are required.
- [3] If your design includes an inductive load such as a motor coil, incorporate a protection circuit into the design to prevent device malfunction or breakdown caused by the current resulting from the inrush current at power ON or the negative current resulting from the back electromotive force at power OFF. IC breakdown may cause injury, smoke or ignition.
Use a stable power supply with ICs with built-in protection functions. If the power supply is unstable, the protection function may not operate, causing IC breakdown. IC breakdown may cause injury, smoke or ignition.
- [4] Do not insert devices in the wrong orientation or incorrectly.
Make sure that the positive and negative terminals of power supplies are connected properly.
Otherwise, the current or power consumption may exceed the absolute maximum rating, and exceeding the rating(s) may cause the device breakdown, damage or deterioration, and may result injury by explosion or combustion.
In addition, do not use any device that is applied the current with inserting in the wrong orientation or incorrectly even just one time.

Points to remember on handling of ICs**(1) Over current Protection Circuit**

Over current protection circuits (referred to as current limiter circuits) do not necessarily protect ICs under all circumstances. If the Over current protection circuits operate against the over current, clear the over current status immediately.

Depending on the method of use and usage conditions, such as exceeding absolute maximum ratings can cause the over current protection circuit to not operate properly or IC breakdown before operation. In addition, depending on the method of use and usage conditions, if over current continues to flow for a long time after operation, the IC may generate heat resulting in breakdown.

(2) Thermal Shutdown Circuit

Thermal shutdown circuits do not necessarily protect ICs under all circumstances. If the thermal shutdown circuits operate against the over temperature, clear the heat generation status immediately.

Depending on the method of use and usage conditions, such as exceeding absolute maximum ratings can cause the thermal shutdown circuit to not operate properly or IC breakdown before operation.

(3) Heat Radiation Design

In using an IC with large current flow such as power amp, regulator or driver, please design the device so that heat is appropriately radiated, not to exceed the specified junction temperature (T_J) at any time and condition. These ICs generate heat even during normal use. An inadequate IC heat radiation design can lead to decrease in IC life, deterioration of IC characteristics or IC breakdown. In addition, please design the device taking into consideration the effect of IC heat radiation with peripheral components.

(4) Back-EMF

When a motor rotates in the reverse direction, stops or slows down abruptly, a current flow back to the motor's power supply due to the effect of back-EMF. If the current sink capability of the power supply is small, the device's motor power supply and output pins might be exposed to conditions beyond maximum ratings. To avoid this problem, take the effect of back-EMF into consideration in system design.

RESTRICTIONS ON PRODUCT USE

070122EBA_R6

- The information contained herein is subject to change without notice. 021023_D
- TOSHIBA is continually working to improve the quality and reliability of its products. Nevertheless, semiconductor devices in general can malfunction or fail due to their inherent electrical sensitivity and vulnerability to physical stress. It is the responsibility of the buyer, when utilizing TOSHIBA products, to comply with the standards of safety in making a safe design for the entire system, and to avoid situations in which a malfunction or failure of such TOSHIBA products could cause loss of human life, bodily injury or damage to property.
In developing your designs, please ensure that TOSHIBA products are used within specified operating ranges as set forth in the most recent TOSHIBA products specifications. Also, please keep in mind the precautions and conditions set forth in the "Handling Guide for Semiconductor Devices," or "TOSHIBA Semiconductor Reliability Handbook" etc. 021023_A
- The TOSHIBA products listed in this document are intended for usage in general electronics applications (computer, personal equipment, office equipment, measuring equipment, industrial robotics, domestic appliances, etc.). These TOSHIBA products are neither intended nor warranted for usage in equipment that requires extraordinarily high quality and/or reliability or a malfunction or failure of which may cause loss of human life or bodily injury ("Unintended Usage"). Unintended Usage include atomic energy control instruments, airplane or spaceship instruments, transportation instruments, traffic signal instruments, combustion control instruments, medical instruments, all types of safety devices, etc. Unintended Usage of TOSHIBA products listed in this document shall be made at the customer's own risk. 021023_B
- The products described in this document shall not be used or embedded to any downstream products of which manufacture, use and/or sale are prohibited under any applicable laws and regulations. 060106_Q
- The information contained herein is presented only as a guide for the applications of our products. No responsibility is assumed by TOSHIBA for any infringements of patents or other rights of the third parties which may result from its use. No license is granted by implication or otherwise under any patents or other rights of TOSHIBA or the third parties. 070122_C
- Please use this product in compliance with all applicable laws and regulations that regulate the inclusion or use of controlled substances.
Toshiba assumes no liability for damage or losses occurring as a result of noncompliance with applicable laws and regulations. 060819_AF
- The products described in this document are subject to foreign exchange and foreign trade control laws. 060925_E