

# PACE1754 SINGLE CHIP, 40MHz CMOS PROCESSOR INTERFACE CIRCUIT (PIC)

## FEATURES

- The PACE1754 (PIC) is a support chip for the PACE1750A/AE Processor. It eliminates the SSI/MSI Logic and external system functions required in typical 1750A implementations.
- Provides a significant savings in part-count and power dissipation enhancing reliability and overall system speed performance.
- Provides an optimal interface when used with the PACE1753 MMU/COMBO in a full 1750A implementation.
- Provides the following additional important system functions:
  - Programmable READY for memory and I/O
  - Automatic READY during self-test and internal I/O instructions
  - 100KHz timer clock output provided
  - Programmable system watchdog—ranges from 1  $\mu$ s to 1 minute
  - Programmable Bus time-out function
  - Memory Parity generation/detection
  - Error detection of unimplemented memory and/or I/O space addressing
  - First failing memory address register for diagnostics
  - High drive three-state address latches
  - Built-in system test program—automatically tests the PACE1750A/AE CPU, PACE1753 MMU/COMBO, PACE1754 PIC and system address lines as well as memory and I/O strobes
  - System configuration decoding and buffering
  - Interrupt acknowledge decoder and strobe
  - Start up ROM support per MIL-STD-1750A
  - Memory or I/O READ/WRITE three-state strobes with external three-state control for DMA applications
- 20, 30 and 40 MHz operation over full Military Temperature Range
- Single 5V  $\pm$  10% Power Supply
- Power Dissipation over Military Temperature Range
  - < 0.25 watts at 20 MHz
  - < 0.30 watts at 30 MHz
  - < 0.35 watts at 40 MHz
- Available in:
  - 64-Pin DIP or Gull Wing (50 Mil Pin centers)
  - 68-Pin Pin Grid Array (PGA) (100 Mil centers)
  - 68-Lead Quad Pack

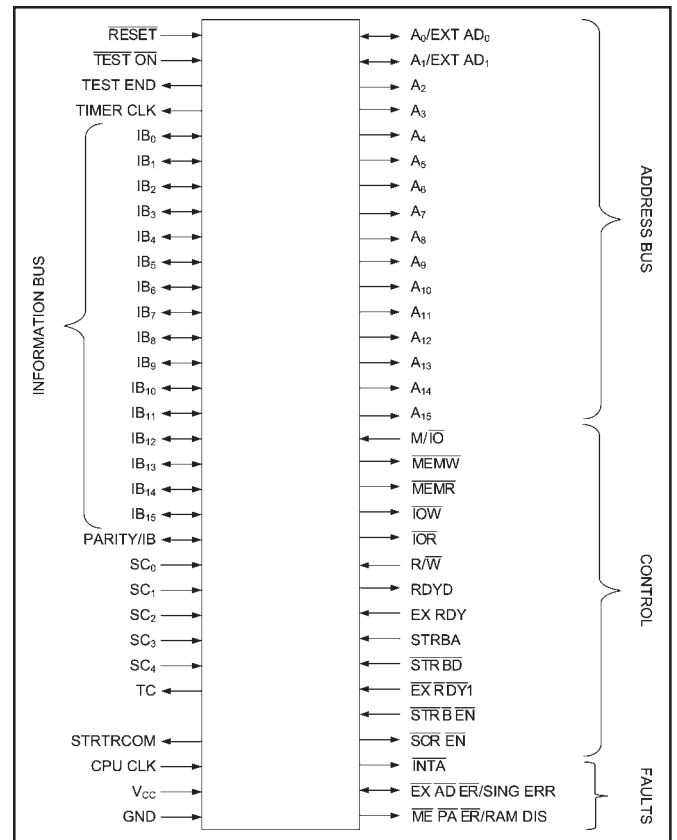

## PACE1754 PROCESSOR INTERFACE CIRCUIT DESCRIPTION

The PACE1754 Processor Interface Circuit (PIC) is a single chip implementation of many special system functions that are often required when using the PACE1750A/AE, single chip, 40MHz CMOS Microprocessor. The PIC allows a system designer to design a higher performance, more efficient microprocessor system which uses less power and takes up less board space than was previously possible.

In addition to providing significant savings in part count and power dissipation the PIC uses only a 5V  $\pm$  10%, single supply and operates at 20, 30 and 40 MHz over the fully Military Temperature Range. The PIC provides many important system functions. These functions are governed by respective bit positions in a programmable Control Register which is incorporated in the PIC. The individual bits of the control register are set to select the various features and are set to a specified default value upon Reset.

## ABSOLUTE MAXIMUM RATINGS<sup>1</sup>

Supply Voltage Range	0.5V to +7.0V
Input Voltage Range	0.5V to $V_{CC} + 0.5V$
Storage Temperature Range	-65°C to +150°C
Input Current Range	-30mA to +5mA
Current applied to any output <sup>3</sup>	150mA
Maximum Power Dissipation <sup>2</sup>	1.5W
Lead Temperature Range (soldering 10 seconds)	300°C
Thermal resistance ( $\theta_{JC}$ ): <sup>4</sup>	
Cases X and T	8°C/W
Cases Y and U	5°C/W
Case Z	6°C/W

### Notes:

1. Stresses above the absolute maximum rating may cause permanent damage to the device. Extended operation at the maximum levels may degrade performance and affect reliability.
2. Must withstand the added power dissipation due to short circuit test e.g.,  $I_{OS}$ .
3. Duration 1 second or less.
4. Device Type Definitions from 5962-88642 SMD:  
 Case X: Dual In-Line  
 Case T: Dual In-Line with Gull-Wing Leads  
 Case Y: Leaded Chip Carrier with Gull-Wing Leads  
 Case U: Leaded Chip Carrier with Unformed Leads  
 Case Z: Pin Grid Array

## RECOMMENDED OPERATING CONDITIONS

Case Temperature	GND	$V_{CC}$
-55°C to +125°C	0	4.5V to +5.5V

**DC ELECTRICAL SPECIFICATIONS** (Over recommended operating conditions)

Symbol	Parameter	Min	Max	Unit	Conditions <sup>1</sup>	
V <sub>IH</sub>	Input HIGH Voltage	2.0	V <sub>CC</sub> + 0.5	V		
V <sub>IL</sub>	Input LOW Voltage	-0.5	0.8	V		
V <sub>CD</sub>	Input Clamp Diode Voltage		-1.2	V	V <sub>CC</sub> = 4.5V, I <sub>IN</sub> = -18mA	
V <sub>OH</sub>	Output HIGH Voltage	2.4		V	V <sub>CC</sub> = 4.5V, I <sub>OH</sub> = -8.0mA	
		V <sub>CC</sub> - 0.2		V	V <sub>IN</sub> = 0.8V, 2.0V I <sub>OH</sub> = -300μA	
V <sub>OL</sub>	Output LOW Voltage, except A <sub>0</sub> - A <sub>15</sub>		0.5	V	V <sub>CC</sub> = 4.5V, I <sub>OL</sub> = 8.0mA	
			0.2	V	V <sub>IN</sub> = 0.8V, 2.0V I <sub>OL</sub> = 300μA	
V <sub>OL</sub>	Output LOW Voltage, A <sub>0</sub> - A <sub>15</sub>		0.5	V	V <sub>CC</sub> = 4.5V, I <sub>OL</sub> = 20.0mA	
			0.2	V	V <sub>IN</sub> = 0.8V, 2.0V I <sub>OL</sub> = 300μA	
I <sub>IH</sub>	Input HIGH Current, except IB <sub>0</sub> - IB <sub>15</sub> , parity/IB <sub>16</sub> , SING ERR, A <sub>0</sub> /EXT AD <sub>0</sub> , A <sub>1</sub> /EXT AD <sub>1</sub> , STRBA		10	μA	V <sub>IN</sub> = V <sub>CC</sub> , V <sub>CC</sub> = 5.5V	
I <sub>IH</sub>	Input HIGH Current, IB <sub>0</sub> - IB <sub>15</sub> , parity/IB <sub>16</sub> , A <sub>0</sub> /EXT AD <sub>0</sub> , A <sub>1</sub> /EXT AD <sub>1</sub>		50	μA	V <sub>IN</sub> = V <sub>CC</sub> , V <sub>CC</sub> = 5.5V	
I <sub>IH</sub>	Input HIGH Current, STRBA, SING ERR		500	μA	V <sub>IN</sub> = V <sub>CC</sub> , V <sub>CC</sub> = 5.5V	
I <sub>IL</sub>	Input LOW Current, except IB <sub>0</sub> - IB <sub>15</sub> , parity/IB <sub>16</sub> , SING ERR, A <sub>0</sub> /EXT AD <sub>0</sub> , A <sub>1</sub> /EXT AD <sub>1</sub> , STRBD, TEST ON		-10	μA	V <sub>IN</sub> = GND, V <sub>CC</sub> = 5.5V	
I <sub>IL</sub>	Input LOW Current, IB <sub>0</sub> - IB <sub>15</sub> , parity/IB <sub>16</sub> , SING ERR, A <sub>0</sub> /EXT AD <sub>0</sub> , A <sub>1</sub> /EXT AD <sub>1</sub>		-50	μA	V <sub>IN</sub> = GND, V <sub>CC</sub> = 5.5V	
I <sub>IL</sub>	Input LOW Current, STRBD, TEST ON		-500	μA	V <sub>IN</sub> = GND, V <sub>CC</sub> = 5.5V	
I <sub>OZH</sub>	Output Three-State Current		50	μA	V <sub>OUT</sub> = 2.4V, V <sub>CC</sub> = 5.5V	
I <sub>OZL</sub>	Output Three-State Current		-50	μA	V <sub>OUT</sub> = 0.5V, V <sub>CC</sub> = 5.5V	
I <sub>CCQC</sub>	Quiescent Power Supply Current (CMOS Input Levels)		10	mA	V <sub>IN</sub> < 0.2V or > V <sub>CC</sub> - 0.2V f = 0MHz, Outputs Open, V <sub>CC</sub> = 5.5V	
I <sub>CCQT</sub>	Quiescent Power Supply Current (TTL Input Levels)		50	mA	V <sub>IN</sub> = 3.4V, f = 0MHz, All Inputs, Outputs Open, V <sub>CC</sub> = 5.5V	
I <sub>CCD</sub>	Dynamic Power Supply Current	f = 20MHz		40	mA	V <sub>IN</sub> = 0V to V <sub>CC</sub> , tr = tf = 2.5 ns typ., Outputs Open, V <sub>CC</sub> = 5.5V
		f = 30MHz		50	mA	
		f = 40MHz		60	mA	
I <sub>OS</sub>	Output Short Circuit Current <sup>2</sup>	-25		mA	V <sub>OUT</sub> = GND, V <sub>CC</sub> = 5.5V	
C <sub>IN</sub>	Input Capacitance		10	pF	Inputs Only	
C <sub>OUT</sub>	Output/Bi-directional Capacitance		15	pF	Outputs Only (Including I/O Buffers)	

**Notes:**

- 4.5V ≤ V<sub>CC</sub> ≤ 5.5V, -55°C ≤ T<sub>C</sub> ≤ +125°C. Unless otherwise specified, testing shall be conducted at worst-case conditions.
- Duration of the short should not exceed one second; only one output may be shorted at a time.

**AC ELECTRICAL CHARACTERISTICS<sup>1, 2</sup>**

 ( $V_{CC} = 5V \pm 10\%$  Over Recommended Operating Conditions)

Symbol	Parameter	20 MHz		30MHz		40 MHz		Unit
		Min	Max	Min	Max	Min	Max	
$t_{EX RDY} (RDYD)_V$	Time from External Ready to Ready Data Valid		16		14		12	ns
$t_C (RDYD)_V$	Time from Clock Read to Ready Data Valid		28		22		16	ns
$t_{STRBA_H} (A)_V$	Time from Strobe Address HIGH to Address Bus Valid		29		21		19	ns
$t_{IBA_V} (A)_V$	Time from Information Bus Address to Address Bus Valid		31		22		20	ns
$t_{FC} (R)_L$	Time from Falling Clock to Read LOW		24		18		12	ns
$t_{STRBD_H} (R)_H$	Time from Strobe Data HIGH to Read HIGH		24		18		12	ns
$t_{STRBD_L} (W)_L$	Time from Strobe Data LOW to Write LOW		26		20		15	ns
$t_{STRBD_H} (W)_H$	Time from Strobe Data HIGH to Write HIGH		26		20		15	ns
$t_{IBD_{IN}} (\overline{ME PA ER})_L$	Time from Information Bus Data into Memory Parity Error LOW		22		17		12	ns
$t_{IBA_{IN}} (\overline{EX AD ER})$	Time from Information Bus Address into External Address Error		30		25		20	ns
$t_{STRBD_L} - (STRT ROM)_V$	Time from Strobe Data LOW to Start-up ROM Valid		26		20		15	ns
$t_{FC} (IB OUT)_V$	Time from Falling Clock to Information Bus Valid		30		25		25	ns
$t_C (TIMER CLK)$	Time from Rising Edge of Clock to Timer Clock		30		25		20	ns
$t_{IB IN_V} (IB16)$	Time from Information Bus Data to Parity Valid		25		20		18	ns
$t_{EXT AD} (CLKB3)$	Extended Address Setup Time	10		10		10		ns
$t_{EX RDY1} (RDYD)_V$	Time from External Ready Data to Ready Data Valid		28		24		21	ns
$t_{FC} (\overline{SCR EN})$	Time from Falling Clock to SCR Enable; Case Types T and X only		30		24		24	ns
$t_{STRBD_H} (\overline{SCR EN})$	Time from STRBD HIGH to SCR Enable; Case Types T and X only		30		24		24	ns

**Notes:**

1.  $4.5V \leq V_{CC} \leq 5.5V$ ,  $-55^\circ C \leq T_C \leq +125^\circ C$ . Unless otherwise specified, testing shall be conducted at worst-case conditions.
2. All measurements of delay times on active signals are related to the 1.5V levels.

## TERMINAL CONNECTIONS

Case Outlines: Dual-In-Line (Case X) and Dual-In-Line with Gull-Wing Leads (Case T)					
Terminal Number	Terminal Symbol	Terminal Number	Terminal Symbol	Terminal Number	Terminal Symbol
1	GND	23	IB <sub>13</sub>	45	A <sub>3</sub>
2	$\overline{\text{SCR EN}}$	24	IB <sub>14</sub>	46	GND
3	$\overline{\text{TEST ON}}$	25	IB <sub>15</sub>	47	A <sub>2</sub>
4	V <sub>CC</sub>	26	IB <sub>16</sub>	48	A <sub>1</sub> /EXT AD <sub>1</sub>
5	$\overline{\text{RESET}}$	27	$\overline{\text{ME PA ER/RAM DIS}}$	49	A <sub>0</sub> /EXT AD <sub>0</sub>
6	TEST END	28	$\overline{\text{EX AD ER/SING ERR}}$	50	TC
7	TIMER CLK	29	$\overline{\text{INTA}}$	51	CPU CLK
8	$\overline{\text{EX RDY}}_1$	30	STRT ROM	52	STRBA
9	IB <sub>0</sub>	31	V <sub>CC</sub>	53	$\overline{\text{STRBD}}$
10	IB <sub>1</sub>	32	GND	54	$\overline{\text{STRBEN}}$
11	IB <sub>2</sub>	33	A <sub>15</sub>	55	EX RDY
12	IB <sub>3</sub>	34	A <sub>14</sub>	56	RDYD
13	IB <sub>4</sub>	35	A <sub>13</sub>	57	R/ $\overline{\text{W}}$
14	IB <sub>5</sub>	36	A <sub>12</sub>	58	GND
15	IB <sub>6</sub>	37	A <sub>11</sub>	59	M/ $\overline{\text{IO}}$
16	IB <sub>7</sub>	38	A <sub>10</sub>	60	$\overline{\text{MEMW}}$
17	IB <sub>8</sub>	39	A <sub>9</sub>	61	$\overline{\text{MEMR}}$
18	IB <sub>9</sub>	40	A <sub>8</sub>	62	$\overline{\text{IOW}}$
19	GND	41	A <sub>7</sub>	63	$\overline{\text{IOR}}$
20	IB <sub>10</sub>	42	A <sub>6</sub>	64	V <sub>CC</sub>
21	IB <sub>11</sub>	43	A <sub>5</sub>		
22	IB <sub>12</sub>	44	A <sub>4</sub>		

## TERMINAL CONNECTIONS

Case Outlines: Leaded Chip Carrier with unformed leads (Case U) and Leaded Chip Carrier with Gull-Wing Leads (Case Y)

Terminal Number	Terminal Symbol	Terminal Number	Terminal Symbol	Terminal Number	Terminal Symbol
1	GND	24	IB <sub>12</sub>	47	A <sub>3</sub>
2	SC <sub>0</sub>	25	IB <sub>13</sub>	48	GND
3	SC <sub>1</sub>	26	IB <sub>14</sub>	49	A <sub>2</sub>
4	$\overline{\text{TEST ON}}$	27	IB <sub>15</sub>	50	A <sub>1</sub> /EXT AD <sub>1</sub>
5	$\overline{\text{RESET}}$	28	PARITY/IB <sub>16</sub>	51	A <sub>0</sub> /EXT AD <sub>0</sub>
6	TEST END	29	$\overline{\text{ME PA ER/RAM DIS}}$	52	SC <sub>4</sub>
7	TIMER CLK	30	$\overline{\text{EX AD ER/SING ERR}}$	53	SC <sub>3</sub>
8	SC <sub>2</sub>	31	$\overline{\text{INTA}}$	54	TC
9	V <sub>CC</sub>	32	STRT ROM	55	CPU CLK
10	IB <sub>0</sub>	33	V <sub>CC</sub>	56	STRBA
11	IB <sub>1</sub>	34	GND	57	$\overline{\text{STRBD}}$
12	IB <sub>2</sub>	35	A <sub>15</sub>	58	$\overline{\text{STRBEN}}$
13	IB <sub>3</sub>	36	A <sub>14</sub>	59	EX RDY
14	IB <sub>4</sub>	37	A <sub>13</sub>	60	RDYD
15	IB <sub>5</sub>	38	A <sub>12</sub>	61	R/ $\overline{\text{W}}$
16	IB <sub>6</sub>	39	A <sub>11</sub>	62	GND
17	IB <sub>7</sub>	40	A <sub>10</sub>	63	M/ $\overline{\text{IO}}$
18	$\overline{\text{EX RDY}}_1$	41	A <sub>9</sub>	64	$\overline{\text{MEMW}}$
19	IB <sub>8</sub>	42	A <sub>8</sub>	65	$\overline{\text{MEMR}}$
20	IB <sub>9</sub>	43	A <sub>7</sub>	66	$\overline{\text{IOW}}$
21	GND	44	A <sub>6</sub>	67	$\overline{\text{IOR}}$
22	IB <sub>10</sub>	45	A <sub>5</sub>	68	V <sub>CC</sub>
23	IB <sub>11</sub>	46	A <sub>4</sub>		

## TERMINAL CONNECTIONS

Case Outline: Pin Grid Array (Case Z)					
Terminal Number	Terminal Symbol	Terminal Number	Terminal Symbol	Terminal Number	Terminal Symbol
B1	V <sub>CC</sub>	L5	SC <sub>1</sub>	D11	A <sub>3</sub>
B2	IB <sub>14</sub>	K5	SC <sub>0</sub>	D10	A <sub>4</sub>
C1	IB <sub>13</sub>	L6	V <sub>CC</sub>	C11	A <sub>5</sub>
C2	IB <sub>12</sub>	K6	$\overline{\text{IOR}}$	C10	A <sub>6</sub>
D1	IB <sub>11</sub>	L7	$\overline{\text{IOW}}$	B11	A <sub>7</sub>
D2	IB <sub>10</sub>	K7	$\overline{\text{MEMR}}$	A10	GND
E1	IB <sub>9</sub>	L8	$\overline{\text{MEMW}}$	B10	A <sub>8</sub>
E2	IB <sub>8</sub>	K8	M/ $\overline{\text{IO}}$	A9	A <sub>9</sub>
F1	$\overline{\text{EX RDY}}_1$	L9	GND	B9	A <sub>10</sub>
F2	IB <sub>7</sub>	K9	R/ $\overline{\text{W}}$	A8	A <sub>11</sub>
G1	IB <sub>6</sub>	L10	RDYD	B8	A <sub>12</sub>
G2	IB <sub>5</sub>	K11	EX RDY	A7	A <sub>13</sub>
H1	IB <sub>4</sub>	K10	$\overline{\text{STRBEN}}$	B7	A <sub>14</sub>
H2	IB <sub>3</sub>	J11	$\overline{\text{STRBD}}$	A6	A <sub>15</sub>
J1	IB <sub>2</sub>	J10	STRBA	B6	GND
J2	IB <sub>1</sub>	H11	CPU CLK	A5	V <sub>CC</sub>
K1	IB <sub>0</sub>	H10	TC	B5	STRT ROM
L2	GND	G11	SC <sub>3</sub>	A4	$\overline{\text{INTA}}$
K2	SC <sub>2</sub>	G10	SC <sub>4</sub>	B4	$\overline{\text{EX ADER}}$
L3	TIMER CLK	F11	A <sub>0</sub> /EXT AD <sub>0</sub>	A3	$\overline{\text{ME PA ER}}$
K3	TEST END	F10	A <sub>1</sub> /EXT AD <sub>1</sub>	B3	PARITY/IB <sub>16</sub>
L4	$\overline{\text{RESET}}$	E11	A <sub>2</sub>	A2	IB <sub>15</sub>
K4	$\overline{\text{TEST ON}}$	E10	GND		

**STRT ROM**

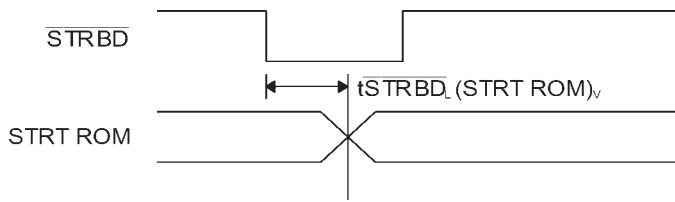

**Timer Clk**

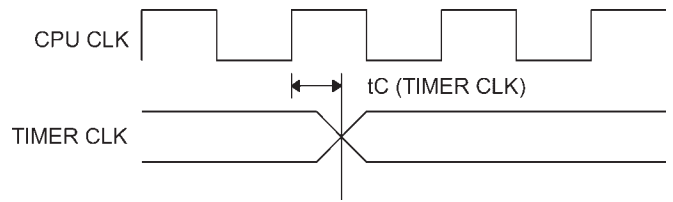

**IB Bus Output (0:15)**

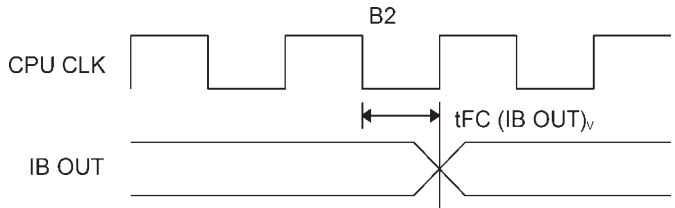

**EX AD ER**

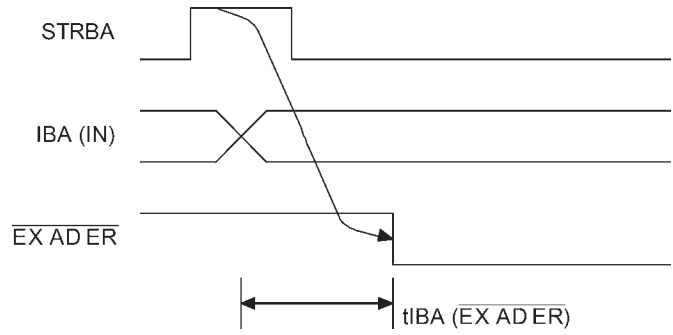

**Extended Addresses (0:1)**

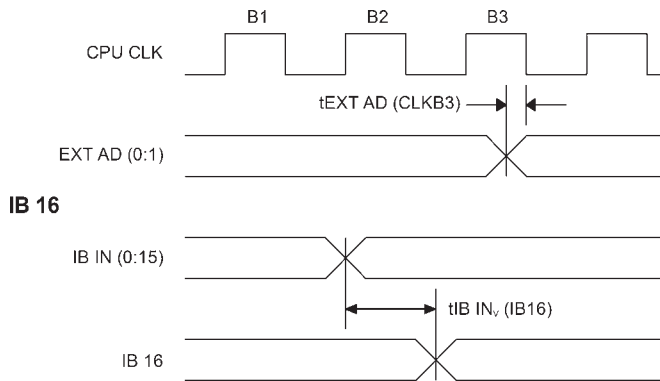

**Note:** All time measurements on active signals relate to 1.5V levels.



**RDYD Timing**

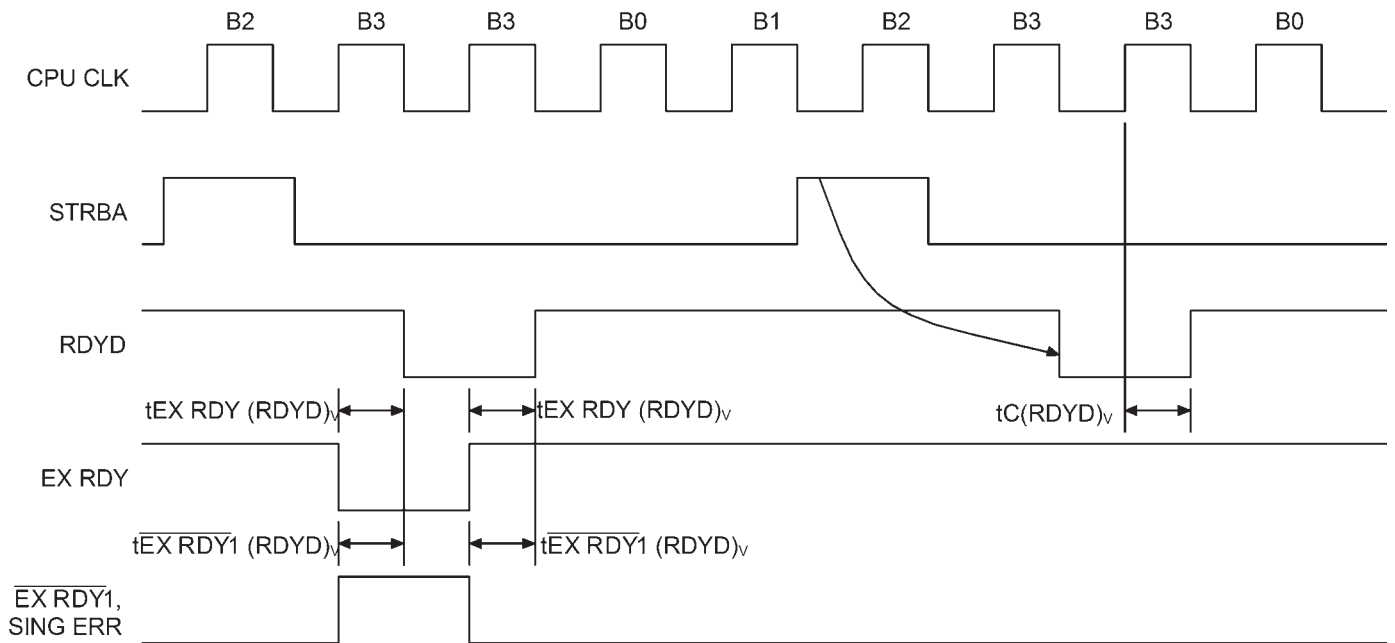

**TEST END Timing<sup>1</sup>**

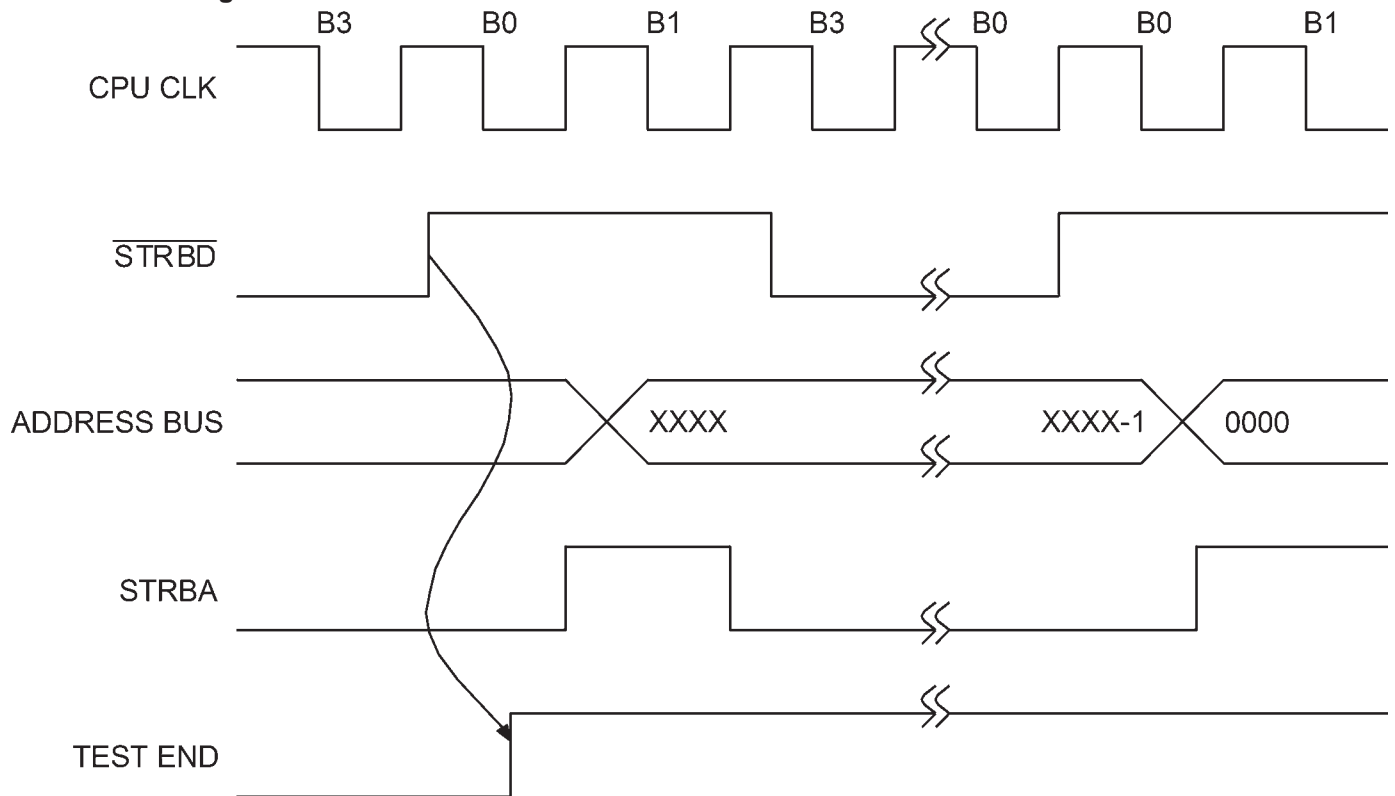

**Notes:**

1. The last two instructions executed during system test are: XIO RA, 1F44, 0 and JC 7, 0000 hex, 0. After execution of the  $\overline{IOW}$  bus cycle, the XIO proceeds by filling the instruction pipe with two memory read bus cycles where the opcode 7070 hex and 0000 hex are entered to the processor. As from the end of  $\overline{STRBD}$  in the second cycle, TEST END is asserted. At this point, the execution of IC starts by first issuing two fetch cycles from the "old PC" (from addresses XXXX & XXXX+1). The data will be taken from system memory (because TEST END is asserted) but both the address and data are irrelevant. Following that, IC will start filling the pipe from address 0000 hex and 0001 hex, now from the system memory to start user's program execution.
2. All time measurements on active signals relate to 1.5V levels.

**Address Bus and Strokes**

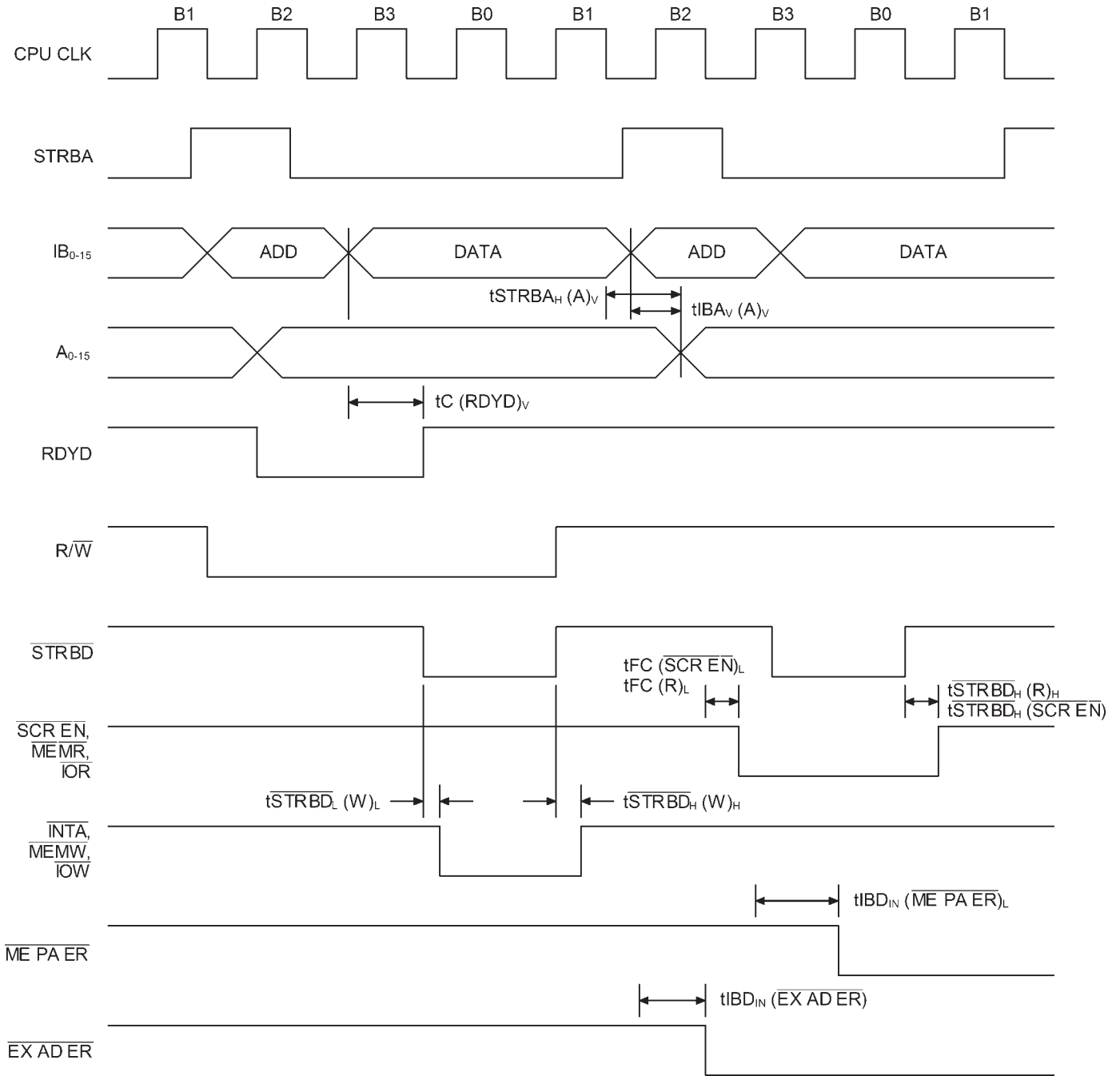

**Note:** All time measurements on active signals relate to 1.5V levels.

## TEST CIRCUITS

### Standard Output (Non Three-State)

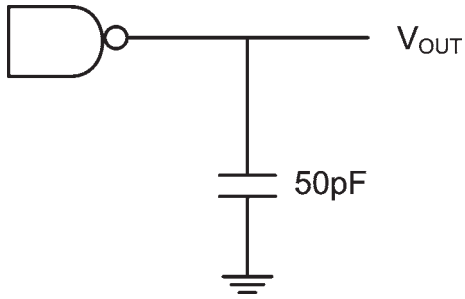

### Three-State

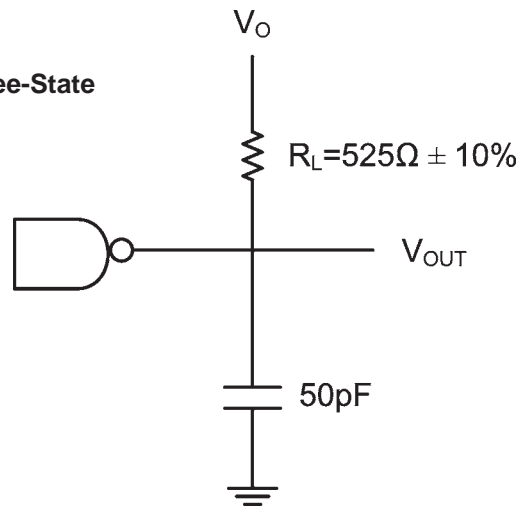

**Note:** All time measurements on active signals relate to 1.5V levels.

Parameter	$V_O$	$V_{MEA}$
TPLZ	$\geq 3V$	0.5V
TPHZ	0V	$V_{CC} - 0.5V$
TPXL	$V_{CC}/2$	1.5V
TPXH	$V_{CC}/2$	1.5V

## PIN FUNCTIONS

Symbol	Name	Description
CPU CLK	CPU Clock	A single-phase input clock signal (0-40MHz, 40% to 60% duty cycle.)
STRBA	Strobe Address	An active HIGH input which latches the contents of IB(0:15) into the address latches.
$\overline{\text{STRBD}}$	Strobe Data	An active LOW input which is used for writing or reading data to or from the device and also to produce the external memory and I/O strobes.
TIMER CLK	Timer Clock	A 100KHz output (fixed frequency) based on the programmed operating frequency of the CPU clock.
$\overline{\text{MEMW}}$	Memory Write Strobe	An active LOW output produced in memory write cycles.
$\overline{\text{MEMR}}$	Memory Read Strobe	An active LOW output produced in memory read cycles.
$\overline{\text{IOW}}$	I/O Write Strobe	An active LOW output produced in output write cycles.
$\overline{\text{IOR}}$	I/O Read Strobe	An active LOW output produced in input read cycles.
$\overline{\text{INTA}}$	Interrupt Acknowledge Strobe	An active LOW output produced after any interrupt, corresponding to an output write to address 1000 (hex).
SCR EN	System Configuration	An active LOW output (in 64 pin only) produced any time an input read from address 8410 (hex), read system configuration is executed.
$\overline{\text{STRBEN}}$	Strobe Enable	An active LOW input, enabling the active state of the address outputs and the MEMR, MEMQ, IOR, and IOW outputs. When at a logic "1" (if enabled by bits EST, EAD of the control register) it will correspondingly enable the three-state state of the above signals.
IB <sub>0</sub> - IB <sub>15</sub>	Information Bus (0:15)	A bi-directional time multiplexed bus. It is an input during the address phase of any bus cycle and also during the data phase when writing. It is an output during the data phase when reading from the device.
IB <sub>16</sub>	Information Bus (16)	A bi-directional line. It is an output during write cycles and an input during read cycles. It is used to implement the parity function at the system level.
A(0:1)/ EX AD(0:1), A(2:15)	Address Bus (0:15)	An active HIGH output bus. Contains the address of the current bus cycle as latched by the end of STRBA. In system configurations including the MMU function, the only active lines during memory are A(4:15). In this case, A(2:3) are high impedance (don't care) and A(0:1) turn into inputs called Extended Addresses, EXT ADR (0:1). In this case, these two lines supplied by the MMU, will be used to operate the programmable ready generation during bus cycles.
M/ $\overline{\text{IO}}$	Memory I/O	An input qualifier indicating the nature of the current bus cycle.

**PIN FUNCTIONS (Continued)**

<b>Symbol</b>	<b>Name</b>	<b>Description</b>
R/W	Read or Write	An input qualifier indicating the nature of the current bus cycle, either Read (1) or Write (0).
RESET	External Reset	An active LOW input used to initialize the device's hardware.
TEST ON	System Test Enable	An active LOW input used to enable the execution of the System Test built into the device, immediately after completion of the P1754 initialization and before fetching any instruction from the user program.
TEST END	System Test End	An active HIGH output indicating whether the system test in the device has been completed. Whenever the system test is disabled by the TEST ON signal, the TEST END output will be at a logical "1" immediately after RESET is removed.
STRT ROM	Start Up ROM	An output following the execution of the ESUR and DSUR, I/O commands as defined in MIL-STD-1750A. It will be at the logical "1" level after executing ESUR and at the logical "0" level after executing DSUR. Initially, it defaults to a logical "1".
RDYD	Ready Data	An active HIGH output to be connected to the P1750A/AE CPU input to control the bus cycle termination.
EX RDY	External Ready Data	An active HIGH input which at logical "0" overrides the internal RDYD generation and forces it to a logical "0".
EX RDY1	External Ready Data	An active LOW input which at logical "1" overrides the internal RDYD generation and forces it to a logical "0".
ME PA ER/ RAM DIS	Memory Parity Error	An active LOW output indicating a parity error when reading from memory. It becomes an active HIGH output called RAM DISABLE for handshaking with the P1753 MMU when the device is programmed to support EDAC.
EX AD ER/ SING ERR	Illegal Address Error	An active LOW output indicating an illegal address error when referencing memory or I/O. It becomes an active HIGH output called SINGLE ERROR for handshaking with the P1753 MMU when the device is programmed to support EDAC.
TC	Terminal Count	An active HIGH output indicating a Bus time out or a watchdog trigger.
SC <sub>0</sub> -SC <sub>4</sub>	System Configuration	Inputs (for case outlines U, Y, and Z only) which are buffered onto IB <sub>0</sub> -IB <sub>4</sub> when executing an I/O read from I/O address 8410 (hex), system configuration.
GND	Ground	0 volts system ground.
V <sub>CC</sub>	Power Supply	5 volts ± 10% power supply.

Case U: Leaded Chip Carrier with Unformed Leads

Case Y: Leaded Chip Carrier with Gull-Wing Leads

Case Z: Pin Grid Array

Standardized Military Drawing PIN	Vendor CAGE Number	Vendor similar PIN
5962-8864201UX	3DTT2	P1754-20QLMB
5962-8864201YX	3DTT2	P1754-20QGMB
5962-8864201ZX	3DTT2	P1754-20PGMB
5962-8864202UX	3DTT2	P1754-30QLMB
5962-8864202YX	3DTT2	P1754-30QGMB
5962-8864202ZX	3DTT2	P1754-30PGMB
5962-8864203UX	3DTT2	P1754-40QLMB
5962-8864203YX	3DTT2	P1754-40QGMB
5962-8864203ZX	3DTT2	P1754-40PGMB
5962-8864204TX	3DTT2	P1754-20GMB
5962-8864204XX	3DTT2	P1754-20CMB
5962-8864205TX	3DTT2	P1754-30GMB
5962-8864205XX	3DTT2	P1754-30CMB
5962-8864206TX	3DTT2	P1754-40GMB
5962-8864206XX	3DTT2	P1754-40CMB

**ORDERING INFORMATION**

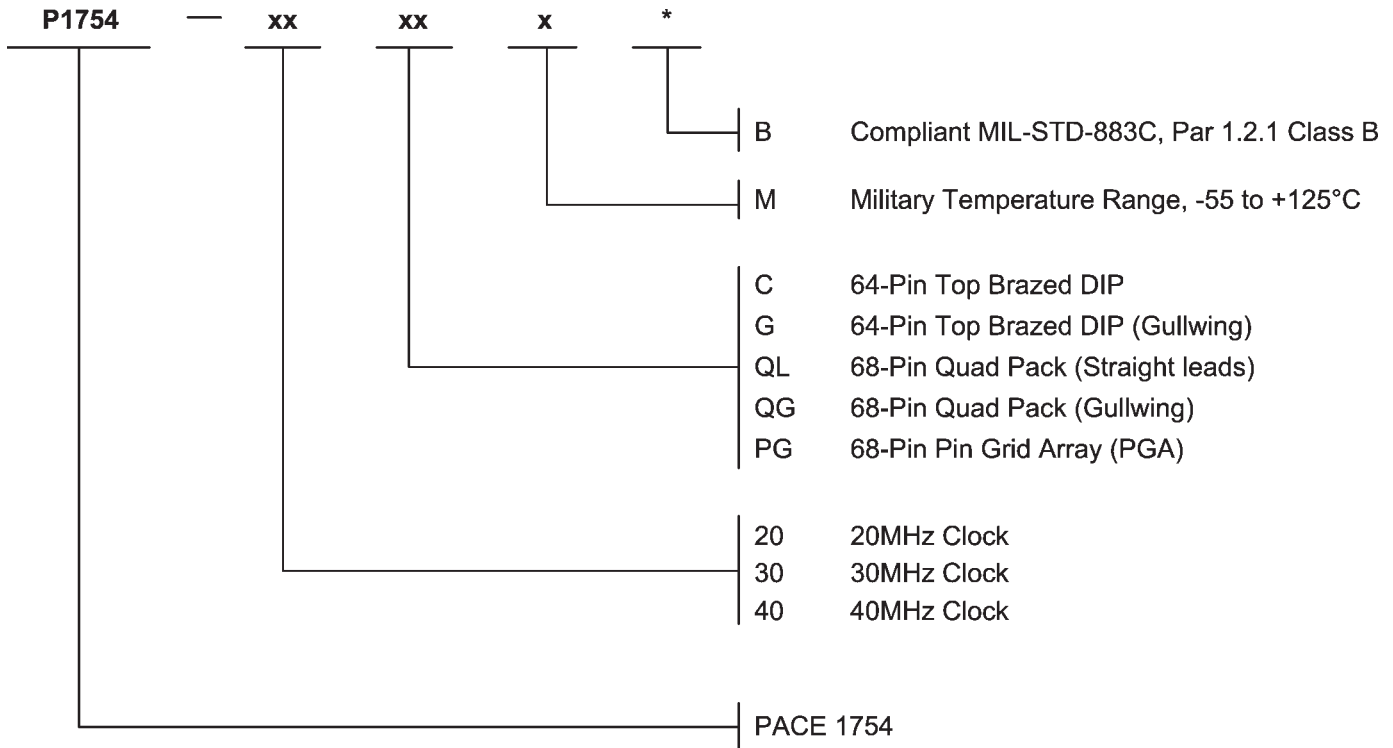

**CASE OUTLINE X:**

64 Lead Top Brazed DIP Package, Straight Lead Version (Ordering Code C)

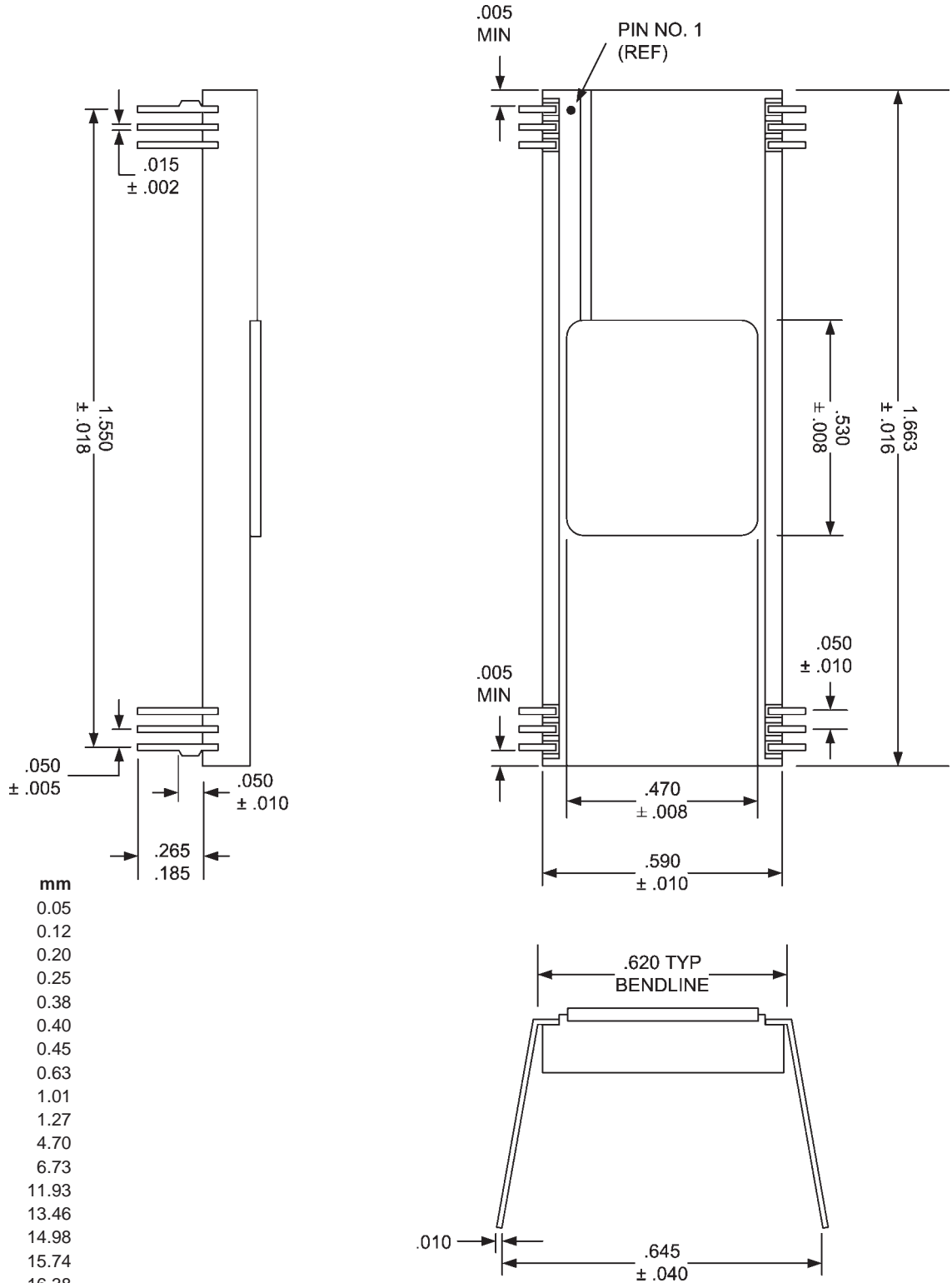

Inches	mm
.002	0.05
.005	0.12
.008	0.20
.010	0.25
.015	0.38
.016	0.40
.018	0.45
.025	0.63
.040	1.01
.050	1.27
.185	4.70
.265	6.73
.470	11.93
.530	13.46
.590	14.98
.620	15.74
.645	16.38
1.550	39.37
1.563	39.70

**NOTES:**

- 1) Dimensions are in inches.
- 2) Metric equivalents are given for general information only.
- 3) Unless otherwise specified, tolerances are .02 (0.5 mm) for two place decimals and .005 (0.13 mm) for three place decimals.

**CASE OUTLINE T:**

64 Lead Top Brazed DIP Package, Gullwing Lead Version (Ordering Code G)

Inches	mm
.001	0.03
.003	0.08
.005	0.12
.008	0.20
.010	0.25
.015	0.38
.016	0.41
.022	0.55
.030	0.76
.040	1.01
.050	1.27
.150	3.81
.470	11.93
.530	13.46
.590	14.98
.620	15.74
.868	22.04
1.663	42.24

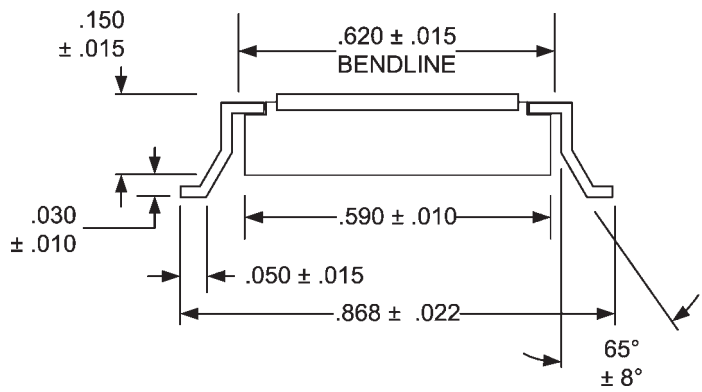
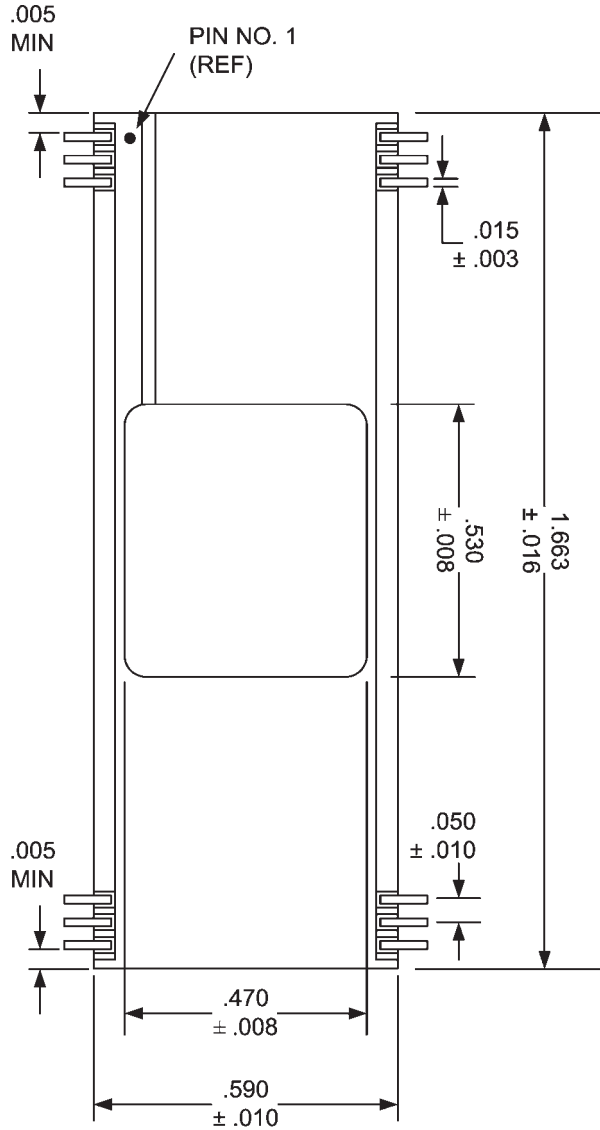

**NOTES:**

- 1) Dimensions are in inches.
- 2) Metric equivalents are given for general information only.
- 3) Unless otherwise specified, tolerances are .02 (0.5 mm) for two place decimals and .005 (0.13 mm) for three place decimals.
- 4) Case T is derived from Case X by forming the leads to the shown gullwing configuration.



**CASE OUTLINE U:**

68 Lead Quad Pack with Straight Leads (Ordering Code QL)

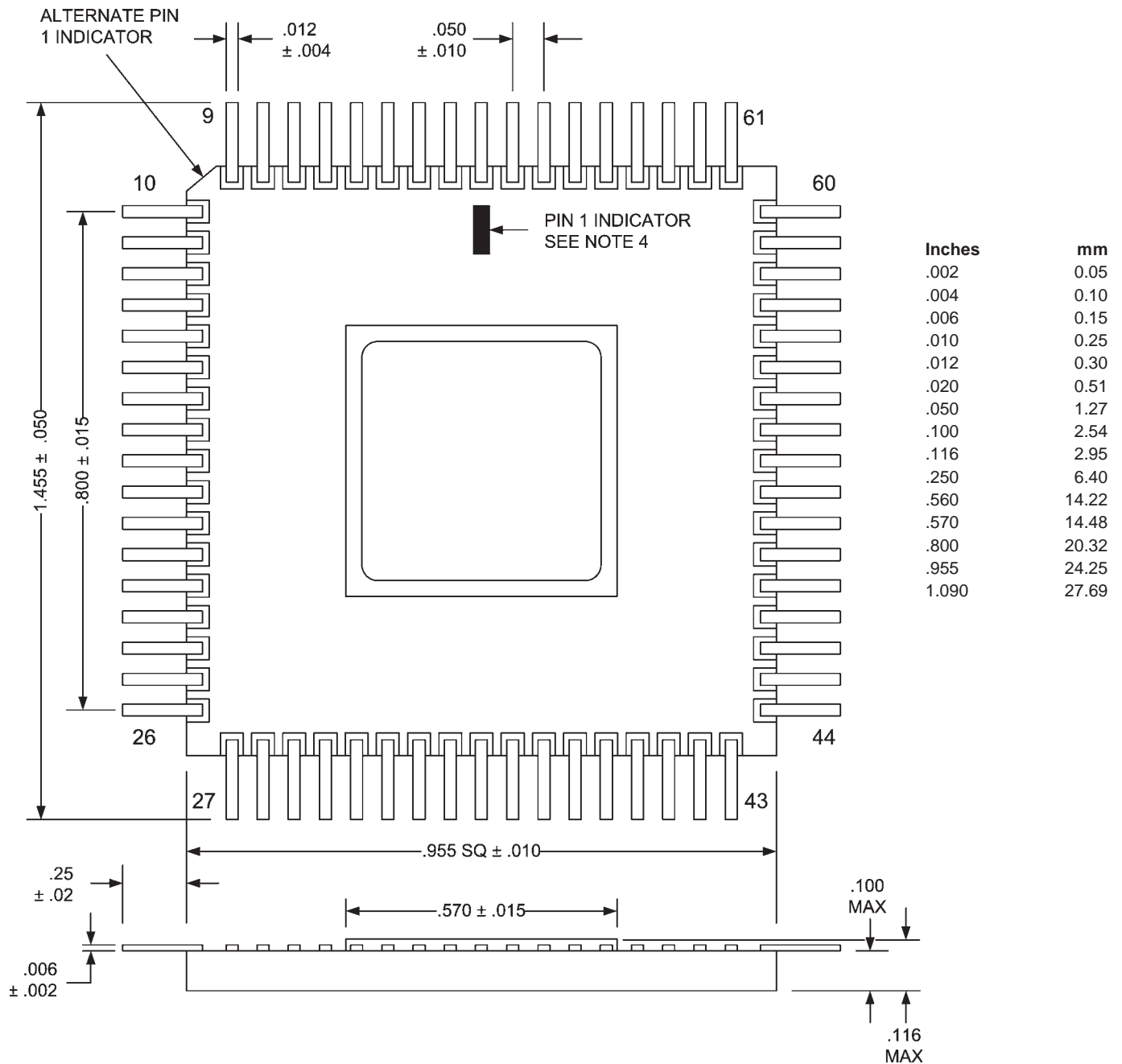

**NOTES:**

- 1) Dimensions are in inches.
- 2) Metric equivalents are given for general information only.
- 3) Unless otherwise specified, tolerances are .02 (0.5 mm) for two place decimals and .005 (0.13 mm) for three place decimals.
- 4) Pin 1 indicator can be either rectangle, dot, or triangle at specified location or referenced to the uniquely beveled corner.
- 5) Corners indicated as notched may be either notched or square.

**CASE OUTLINE Y:**

**68 Lead Quad Pack with Gullwing Leads (Ordering Code QG)**

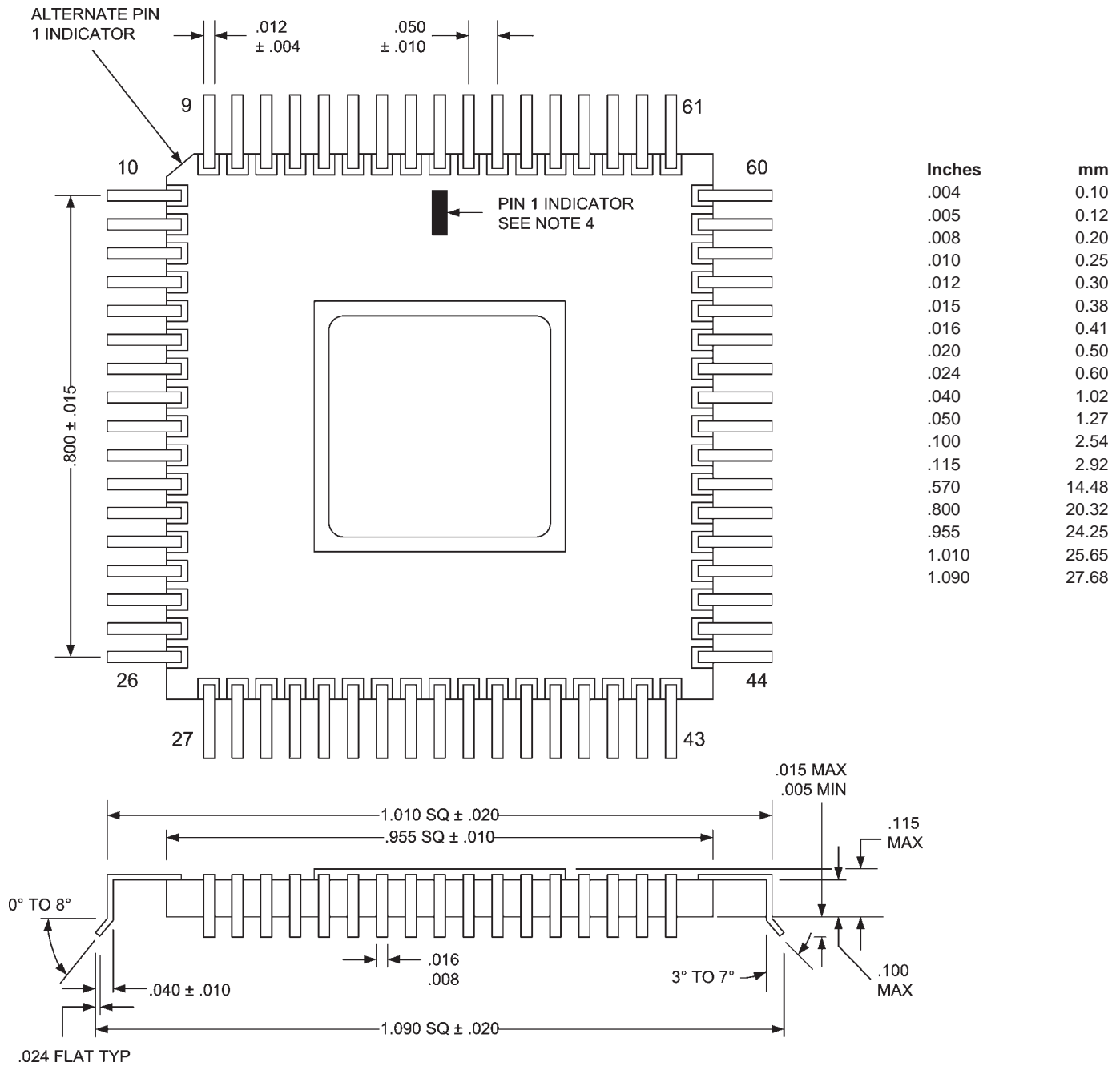

**NOTES:**

- 1) Dimensions are in inches.
- 2) Metric equivalents are given for general information only.
- 3) Unless otherwise specified, tolerances are .02 (0.5 mm) for two place decimals and .005 (0.13 mm) for three place decimals.
- 4) Pin 1 indicator can either be rectangle, dot, or triangle at specified location or referenced to the uniquely beveled corner.
- 5) Corners indicated as notched may be either notched or square (with radius).
- 6) Case Y is derived from Case U by forming the leads to the shown gullwing configuration.

**CASE OUTLINE Z:**

68-Pin Pin Grid Array (PGA) (Ordering Code PG)

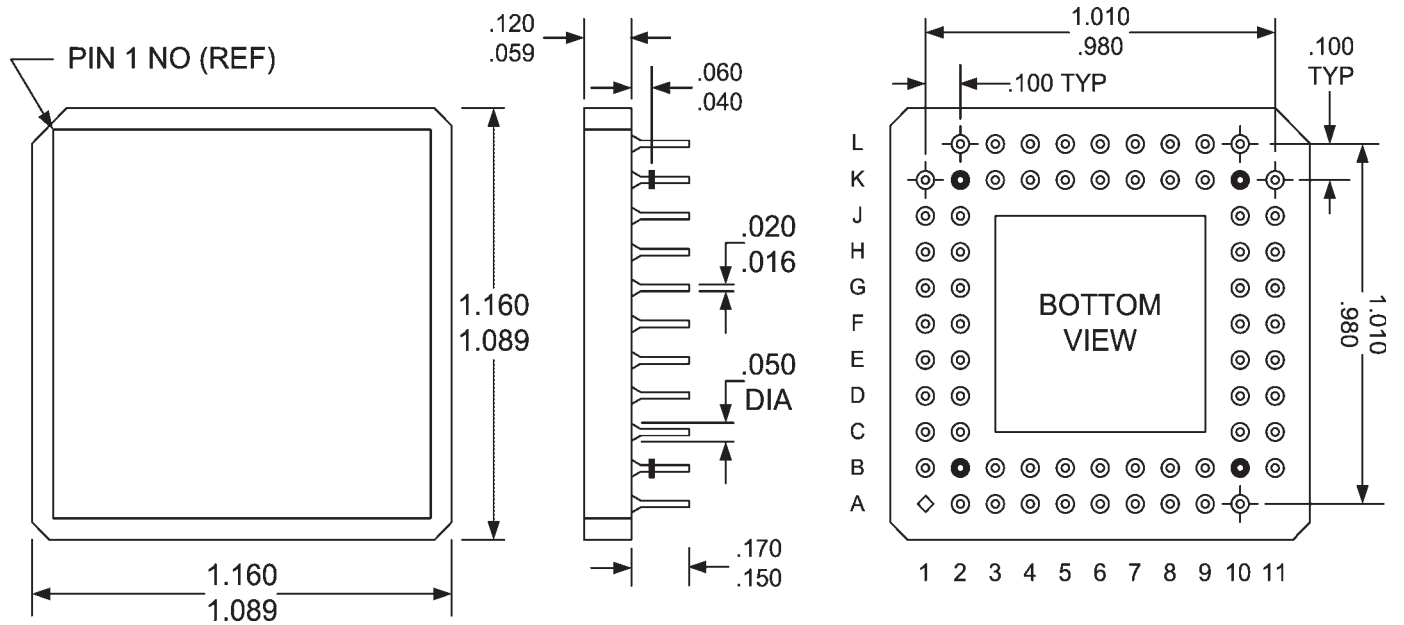

Inches	mm
.016	0.41
.020	0.50
.040	1.01
.050	1.27
.059	1.49
.060	1.52
.098	2.49
.100	2.54
.120	3.04
.150	3.81
.170	4.32
1.010	25.65
1.089	27.66
1.160	29.46

**NOTES:**

- 1) Dimensions are in inches.
- 2) Metric equivalents are given for general information only.
- 3) Unless otherwise specified, tolerances are .02 (0.5 mm) for two place decimals and .005 (0.13 mm) for three place decimals.
- 4) Corners except pin number 1 (ref.) can be either rounded or square.
- 5) All pins must be on the .100" grid.

**REVISIONS**

<b>DOCUMENT NUMBER:</b>		MICRO-5	
<b>DOCUMENT TITLE:</b>		PACE1754 PIC BULK CMOS	
REV.	ISSUE DATE	ORIG. OF CHANGE	DESCRIPTION OF CHANGE
ORIG	May-89	RKK	New Data Sheet
A	Jul-04	JDB	Added Pyramid logo
B	Aug-05	JDB	Re-created electronic version
C	11/15/05	JDB	Removed Commercial Temperature Range