

Legacy Device: Motorola MC13135

The ML13135 is the second generation of single chip, dual conversion FM communications receivers developed by Motorola. Major improvements in signal handling, RSSI and first oscillator operation have been made. In addition, recovered audio distortion and audio drive have improved. These receivers offer low noise, high gain and stability over a wide operating voltage range, and Lansdale is pleased to continue to offer them.

The ML13135 includes a Colpitts oscillator, VCO tuning diode, low noise first and second mixer and LO, high gain limiting IF, and RSSI. The ML13135 is designed for use with an LC quadrature detector and has an uncommitted op amp that can be used either for an RSSI buffer or as a data comparator.

This device can be used as a stand-alone VHF receiver or as the lower IF of a triple conversion system. Applications include cordless telephones, short range data links, walkie-talkies, low cost land mobile, amateur radio receivers, baby monitors and scanners.

OPERATING FEATURES

- Complete Dual Conversion FM Receiver – Antenna to Audio Output
- Input Frequency Range – 200 MHz
- Voltage Buffered RSSI with 70 dB of Usable Range
- Low Voltage Operation – 2.0 to 6.0 Vdc (2 Cell NiCad Supply)
- Low Current Drain – 3.5 mA Typ
- Low Impedance Audio Output < 25 Ω
- VHF Colpitts First LO for Crystal or VCO Operation
- Isolated Tuning Diode
- Buffered First LO Output to Drive CMOS PLL Synthesizer
- Operating Temperature Range $T_A = -40^\circ$ to $+85^\circ\text{C}$

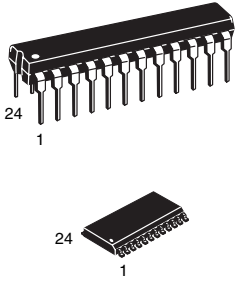

**P DIP 24 = LP
PLASTIC PACKAGE
CASE 724**

**SO 24 = -6P
CASE 751E
(SO-24L)**

PACKAGE	MOTOROLA	LANSDALE
P DIP 24	MC13135P	ML13135LP
SO 24	MC13135DW	ML13135-6P

CROSS REFERENCE/ORDERING INFORMATION

Note: Lansdale lead free (Pb) product, as it becomes available, will be identified by a part number prefix change from ML to MLE.

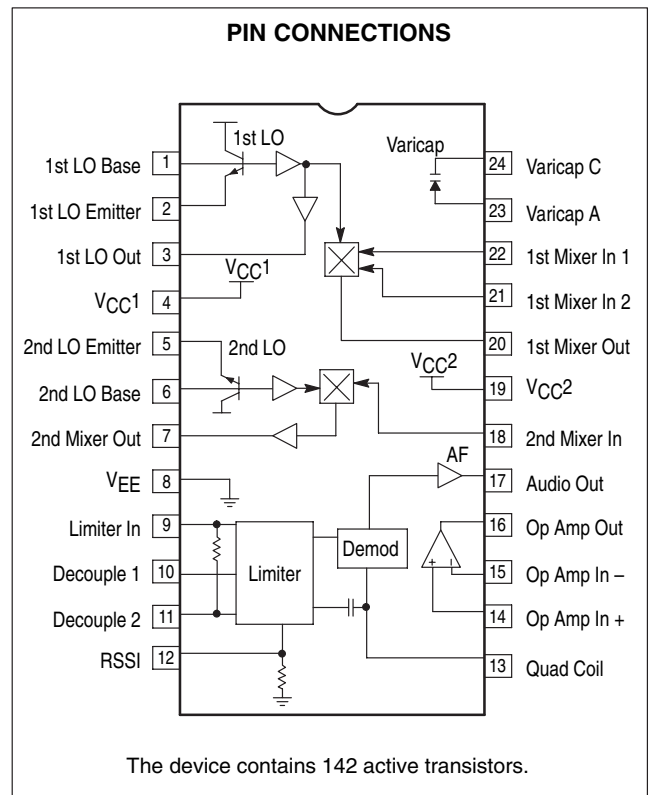

MAXIMUM RATINGS

Rating	Pin	Symbol	Value	Unit
Power Supply Voltage	4, 19	V _{CC} (max)	6.5	V _{dc}
RF Input Voltage	22	RF _{in}	1.0	V _{rms}
Junction Temperature	–	T _J	+150	°C
Storage Temperature Range	–	T _{stg}	– 65 to +150	°C

RECOMMENDED OPERATING CONDITIONS

Rating	Pin	Symbol	Value	Unit
Power Supply Voltage	4, 19	V _{CC}	2.0 to 6.0	V _{dc}
Maximum 1st IF	–	f _{IF1}	21	MHz
Maximum 2nd IF	–	f _{IF2}	3.0	MHz
Ambient Temperature Range	–	T _A	– 40 to + 85	°C

ELECTRICAL CHARACTERISTICS (T_A=25°C, V_{CC}=4.0V_{dc}, f_o=49.7 MHz, f_{MOD}=1.0 kHz, Deviation=±3.0 kHz, f_{1stLO}=39 MHz, f_{2nd LO}=10.245 MHz, IF1=10.7 MHz, IF2=455 kHz, unless otherwise noted. All measurements performed in the test circuit of Figure 1.)

Characteristic	Condition	Symbol	Min	Typ	Max	Unit
Total Drain Current	No Input Signal	I _{CC}	–	4.0	6.0	mA _{dc}
Sensitivity (Input for 12 dB SINAD)	Matched Input	V _{SIN}	–	1.0	–	μV _{rms}
Recovered Audio	V _{RF} = 1.0 mV	AF _O	170	220	300	mV _{rms}
1st Mixer Conversion Gain	V _{RF} = – 40 dBm	MX _{gain1}	–	12	–	dB
2nd Mixer Conversion Gain	V _{RF} = – 40 dBm	MX _{gain2}	–	13	–	dB
First LO Buffered Output	–	V _{LO}	–	100	–	mV _{rms}
Total Harmonic Distortion	V _{RF} = – 30 dBm	THD	–	1.2	3.0	%
Demodulator Bandwidth	–	BW	–	50	–	kHz
RSSI Dynamic Range	–	RSSI	–	70	–	dB
First Mixer 3rd Order Intercept (Input)	Matched Unmatched	TOI _{Mix1}	– –	–17 –11	– –	dBm
Second Mixer 3rd Order Intercept (RF Input)	Matched Input	TOI _{Mix2}	–	– 27	–	dBm
First LO Buffer Output Resistance	–	R _{LO}	–	–	–	Ω
First Mixer Parallel Input Resistance	–	R	–	722	–	Ω
First Mixer Parallel Input Capacitance	–	C	–	3.3	–	pF
First Mixer Output Impedance	–	Z _O	–	330	–	Ω
Second Mixer Input Impedance	–	Z _I	–	4.0	–	kΩ
Second Mixer Output Impedance	–	Z _O	–	1.8	–	kΩ
Detector Output Impedance	–	Z _O	–	25	–	Ω

TEST CIRCUIT INFORMATION

The recovered audio measurements for the ML13135 are made with an LC quadrature detector. The typical recovered audio will depend on the external circuit; either the Q of the quad coil, or the RC matching network for the ceramic discriminator. See Figures 10 and 11 for additional information.

Since adding a matching circuit to the RF input increases the signal level to the mixer, the third order intercept (TOI) point

is better with an unmatched input (50 Ω from Pin 21 to Pin 22). Typical values for both have been included in the Electrical Characterization Table. TOI measurements were taken at the pins with a high impedance probe/spectrum analyzer system. The first mixer input impedance was measured at the pin with a network analyzer.

Figure 1a. ML13135 Test Circuit

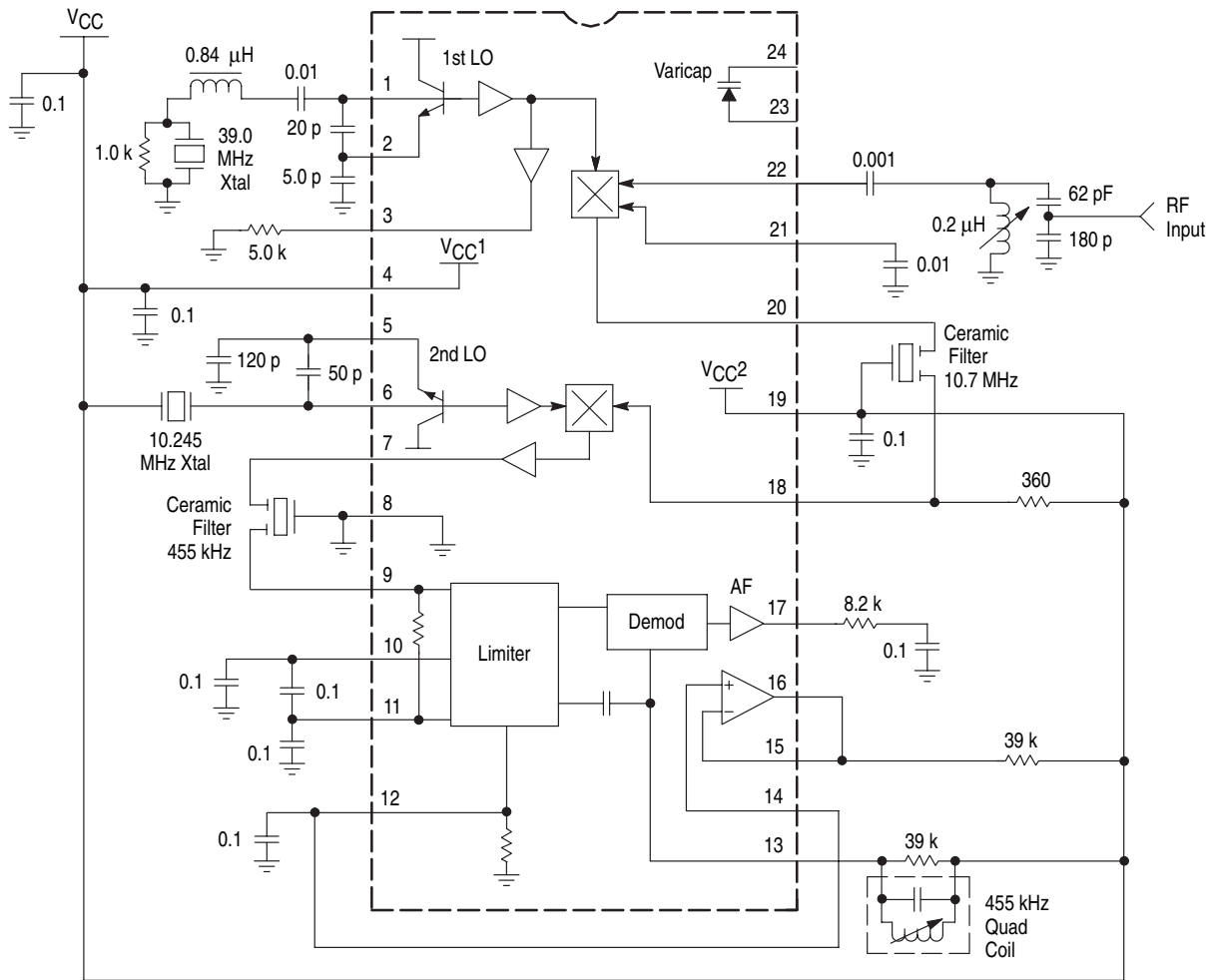

Figure 2. Supply Current versus Supply Voltage

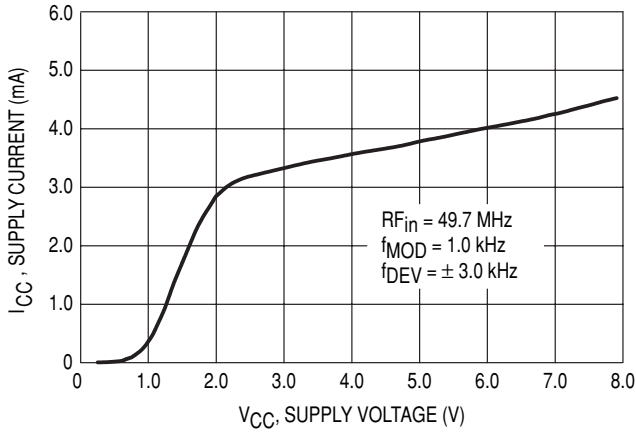

Figure 3. RSSI Output versus RF Input

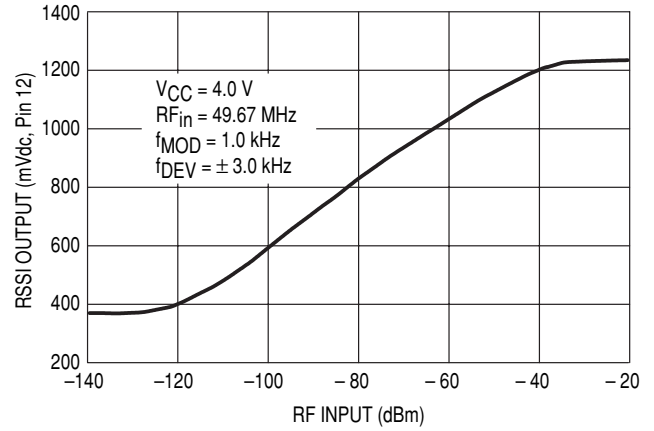

Figure 4. Varactor Capacitance, Resistance versus Bias Voltage

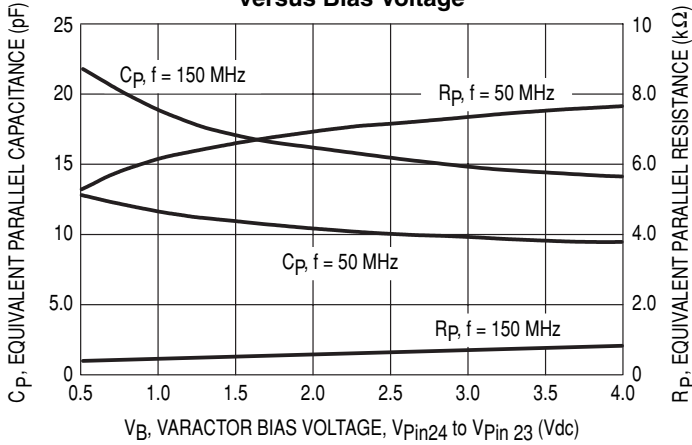

Figure 5. Oscillator Frequency versus Varactor Bias

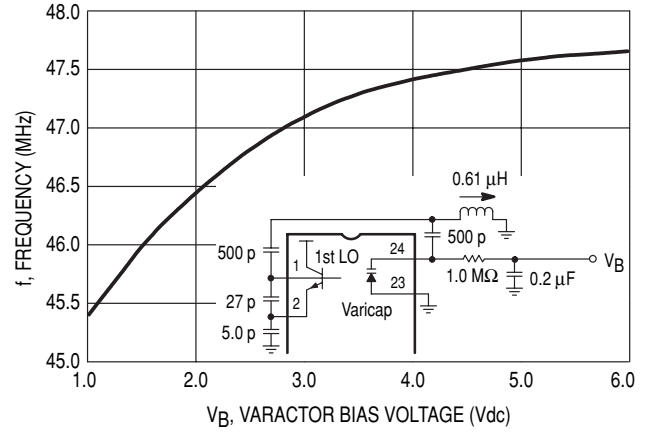

Figure 6. Signal Levels versus RF Input

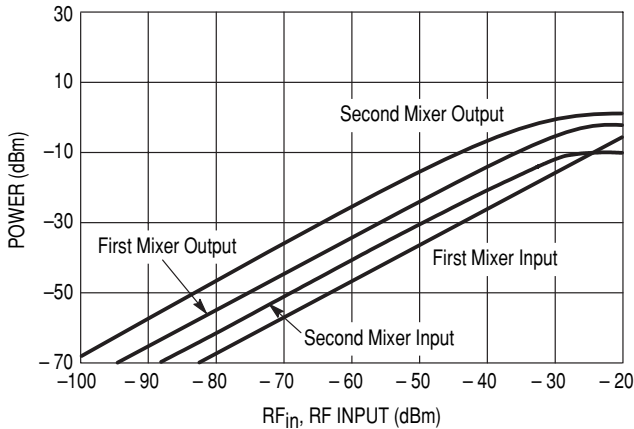

Figure 7. Signal + Noise, Noise, and AM Rejection versus Input Power

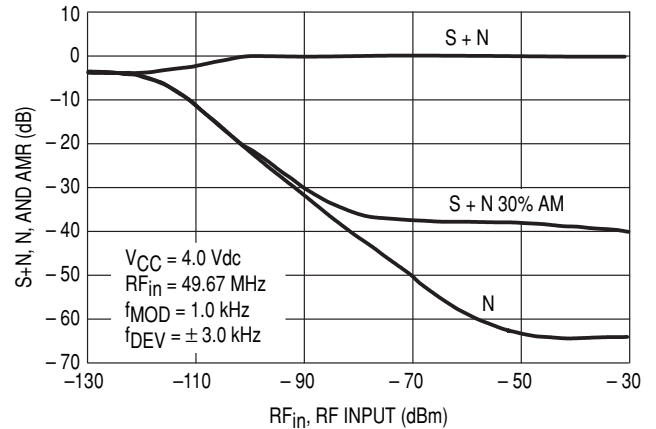

Figure 8. Op Amp Gain and Phase versus Frequency

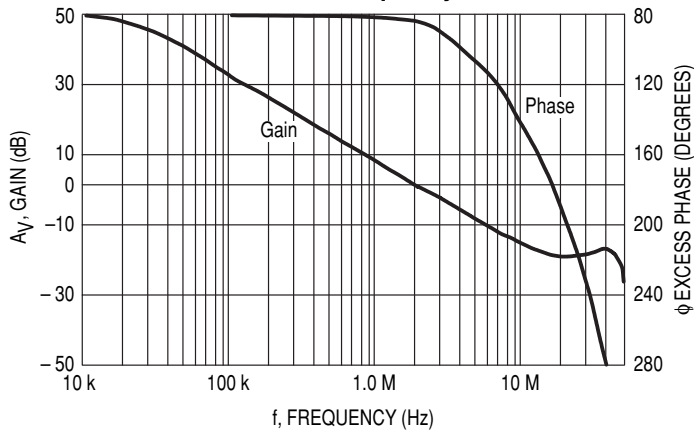

Figure 9. First Mixer Third Order Intermodulation (Unmatched Input)

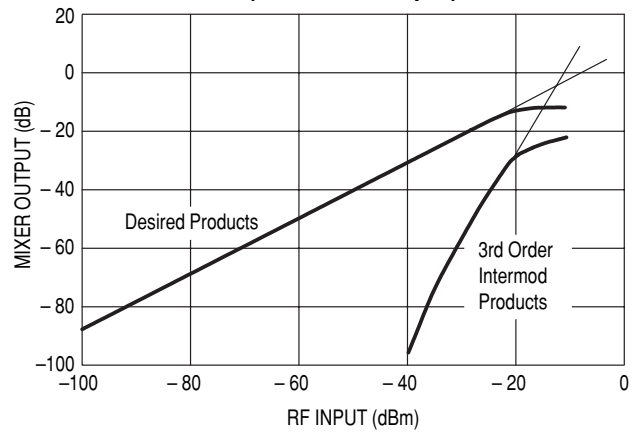

Figure 10. Recovered Audio versus Deviation for ML13135

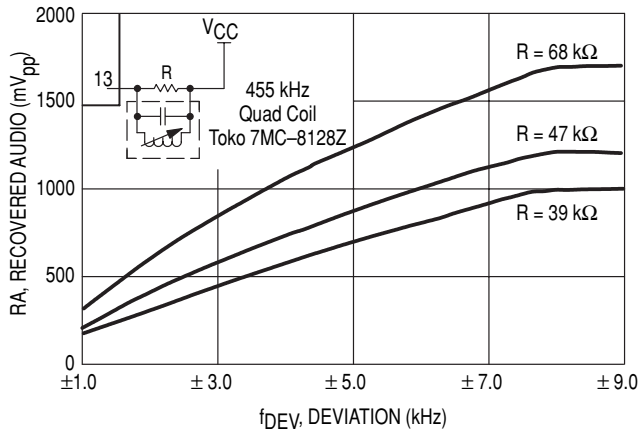
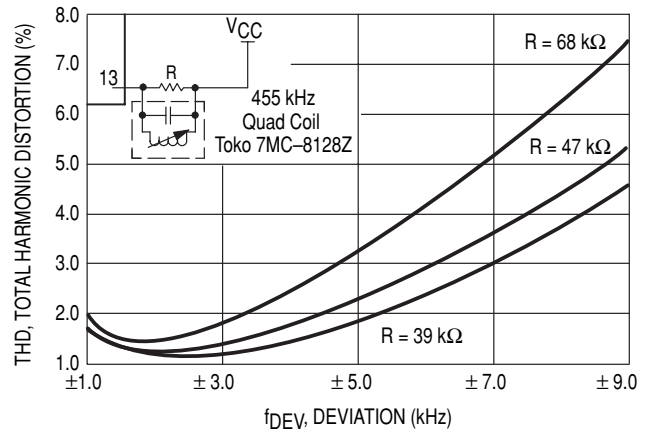

Figure 11. Distortion versus Deviation for ML13135



CIRCUIT DESCRIPTION

The ML13135 is a complete dual conversion receiver. This includes two local oscillators, two mixers, a limiting IF amplifier and detector, and an op amp. It will provide a voltage buffered RSSI with 70 dB of usable range, isolated tuning diode and buffered LO output for PLL operation, and a separate V_{CC} pin for the first mixer and LO. Improvements have been made in the temperature performance of both the recovered audio and the RSSI.

V_{CC}

Two separate V_{CC} lines enable the first LO and mixer to continue running while the rest of the circuit is powered down. They also isolate the RF from the rest of the internal circuit.

Local Oscillators

The local oscillators are grounded collector Colpitts, which can be easily crystal-controlled or VCO controlled with the on-board varactor and external PLL. The first LO transistor is internally biased, but the emitter is pinned-out and IQ can be increased for high frequency or VCO operation. The collector is not pinned out, so for crystal operation, the LO is generally limited to 3rd overtone crystal frequencies; typically around 60 MHz. For higher frequency operation, the LO can be provided externally as shown in Figure 16.

Buffer

An amplifier on the 1st LO output converts the single-ended LO output to a differential signal to drive the mixer. Capacitive coupling between the LO and the amplifier minimizes the effects of the change in oscillator current on the mixer. Buffered LO output is pinned-out at Pin 3 for use with a PLL, with a typical output voltage of 320 mVpp at $V_{CC}=4.0$ V and with a 5.1 k resistor from Pin 3 to ground. As seen in Figure 14, the buffered LO output varies with the supply voltage and a smaller external resistor may be needed for low voltage operation. The LO buffer operates up to 60 MHz, typically. Above 60 MHz, the output at Pin 3 rolls off at approximately 6.0 dB per octave. Since most PLLs require about 200 mVpp drive, an external amplifier may be required.

Mixers

The first and second mixer are of similar design. Both are double balanced to suppress the LO and input frequencies to give only the sum and difference frequencies out. This configuration typically provides 40 to 60 dB of LO suppression. New design techniques provide improved mixer linearity and third order intercept without increased noise. The gain on the output of the 1st mixer starts to roll off at about 20 MHz, so this receiver could be used with a 21 MHz first IF. It is designed for use with a ceramic filter, with an output impedance of 330 Ω . A series resistor can be used to raise the impedance for use with a crystal filter, which typically has an input impedance of 4.0 k Ω . The second mixer input impedance is approximately 4.0 k Ω ; it requires an external 360 Ω parallel resistor for use with a standard ceramic filter.

Limiting IF Amplifier and Detector

The limiter has approximately 110 dB of gain, which starts rolling off at 2.0 MHz. Although not designed for wideband operation, the bandwidth of the audio frequency amplifier has been widened to 50 kHz, which gives less phase shift and enables the receiver to run at higher data rates. However, care should be taken not to exceed the bandwidth allowed by local regulations.

The ML13135 is designed for use with an LC quadrature detector, and does not have sufficient drive to be used with a ceramic discriminator. The discriminators and the external matching circuit will affect the distortion and recovered audio.

RSSI/Op Amp

The Received Signal Strength Indicator (RSSI) on the ML13135 has about 70 dB of range. The resistor needed to translate the RSSI current to a voltage output has been included on the internal circuit, which gives it a tighter tolerance. A temperature compensated reference current also improves the RSSI accuracy over temperature. On the ML13135, the op amp is not connected internally and can be used for the RSSI or as a data slicer (see Figure 17c).

Figure 14. Buffered LO Output Voltage versus Supply Voltage

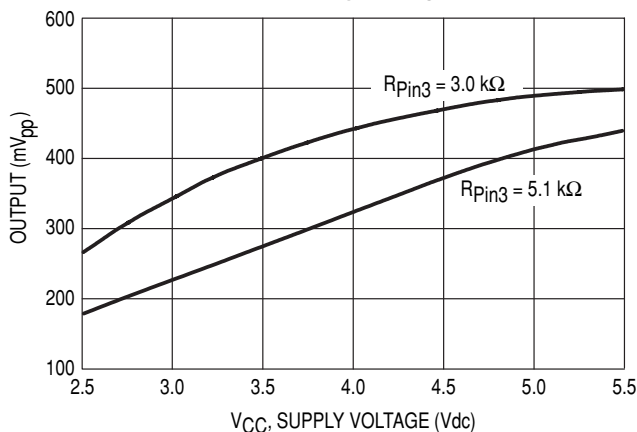

Figure 15. PLL Controlled Narrowband FM Receiver at 46/49 MHz

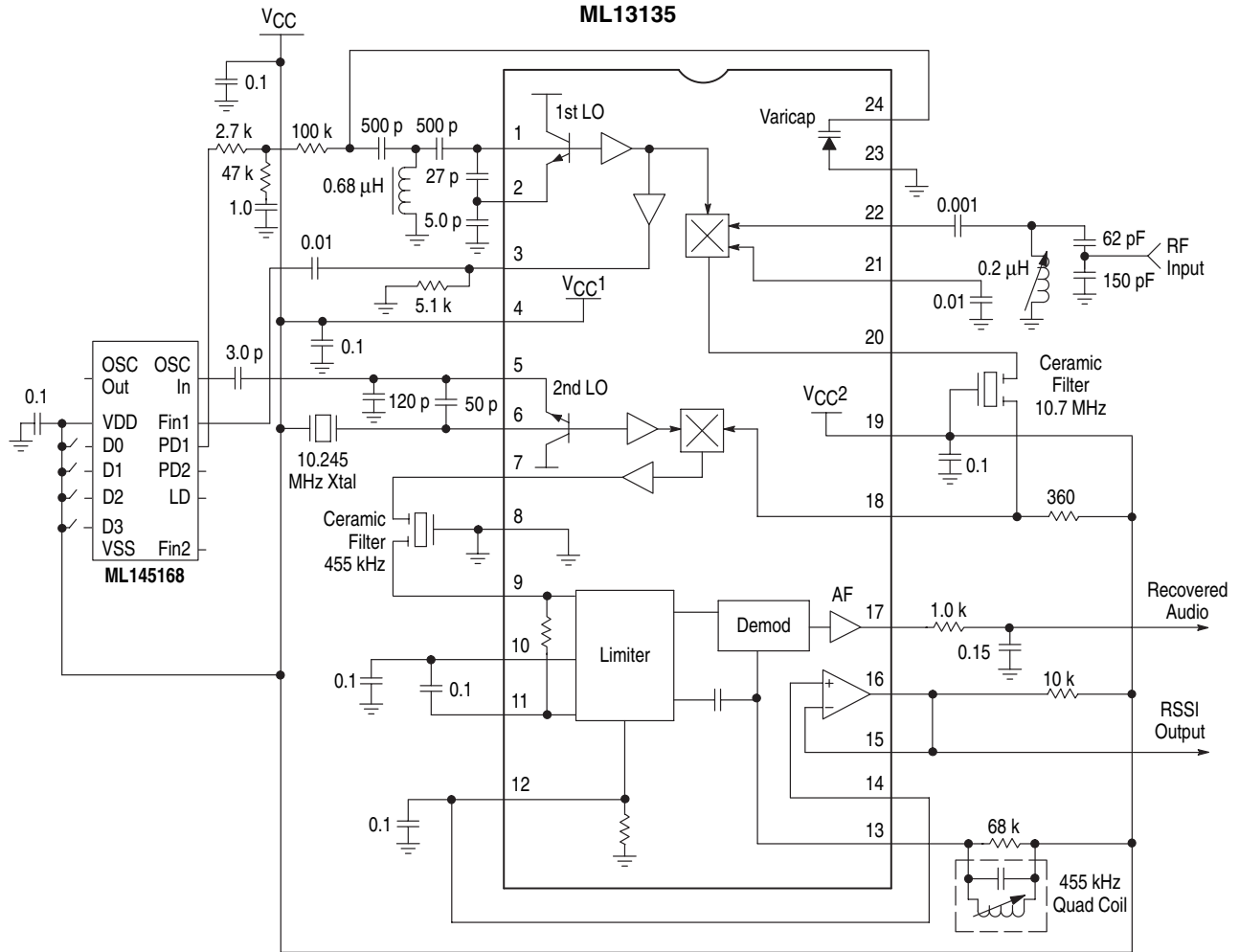
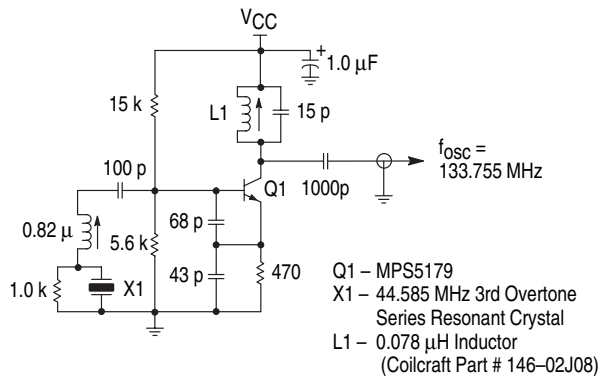
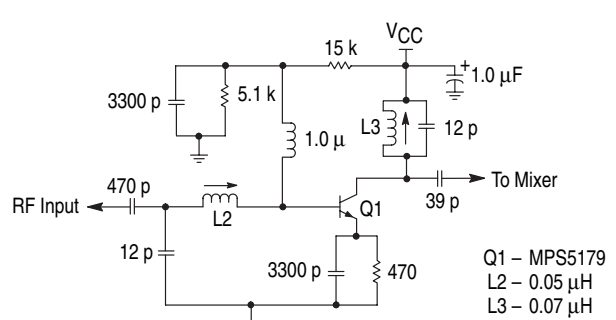

Figure 16. 144 MHz Single Channel Application Circuit

1st LO External Oscillator Circuit



Preamp for ML13135 at 144.455 MHz



Legacy Applications Information

Figure 17a. Single Channel Narrowband FM Receiver at 49.7 MHz

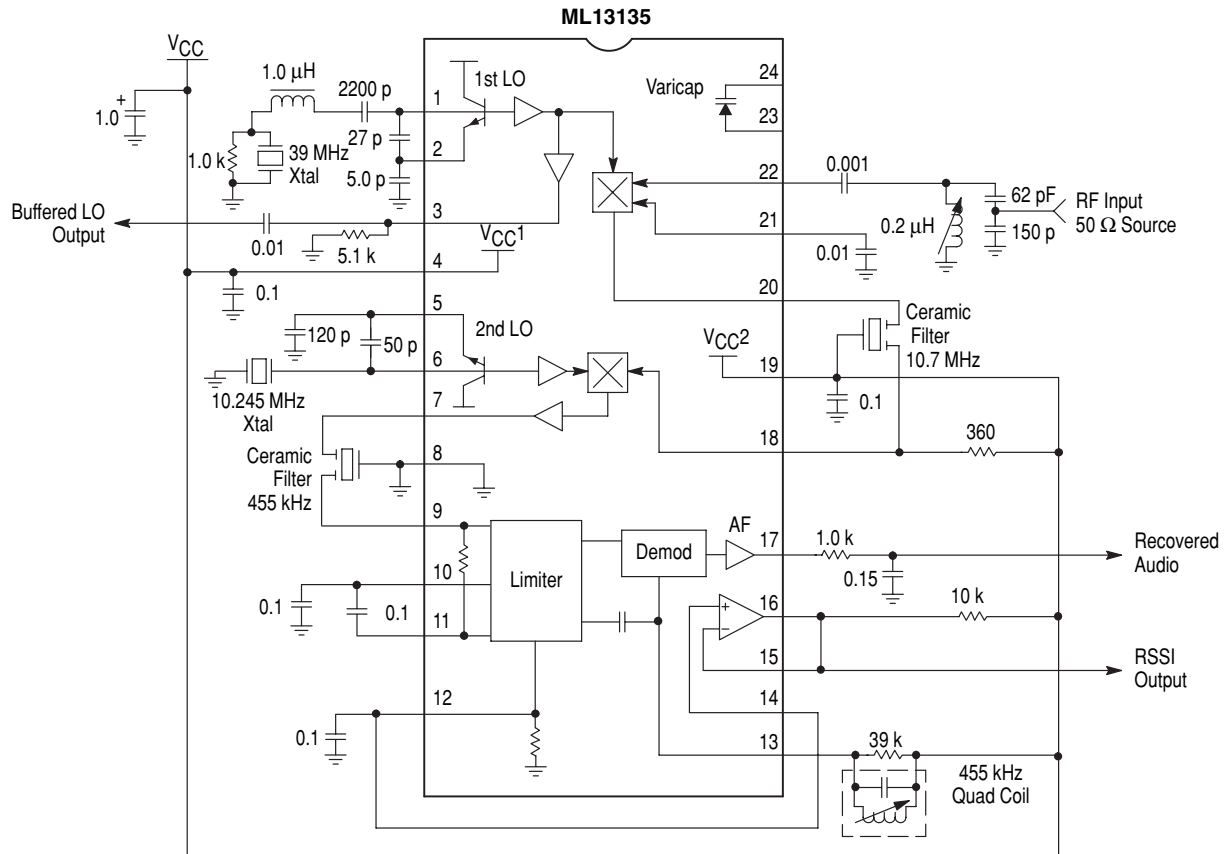
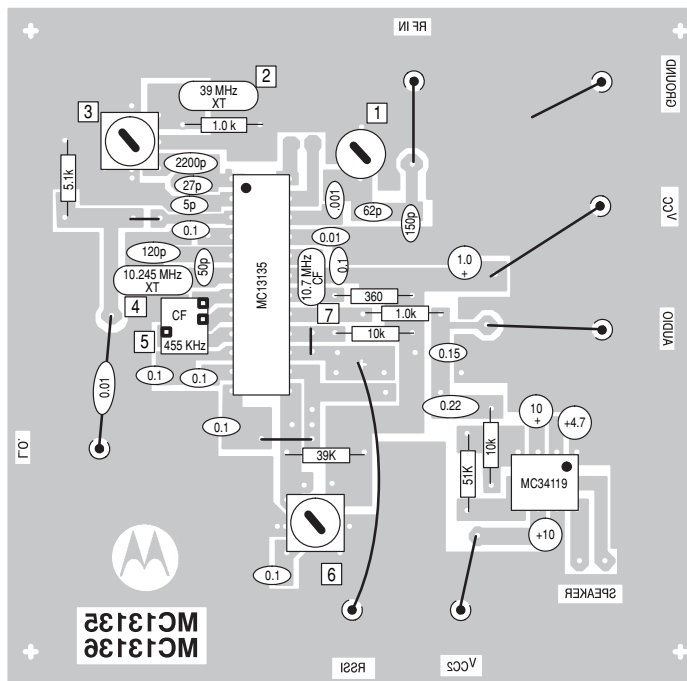

Figure 17b. PC Board Component View



- NOTES:**
1. 0.2 μ H tunable (unshielded) inductor
 2. 39 MHz Series mode resonant 3rd Overtone Crystal
 3. 1.5 μ H tunable (shielded) inductor
 4. 10.245 MHz Fundamental mode crystal, 32 pF load
 5. 455 kHz ceramic filter, muRata CFU 455B or equivalent
 6. Quadrature coil, Toko 7MC-8128Z (7mm) or Toko RMC-2A6597HM (10mm)
 7. 10.7 MHz ceramic filter, muRata SFE10.7MJ-A or equivalent

Figure 17c. Optional Data Slicer Circuit (Using Internal Op Amp)

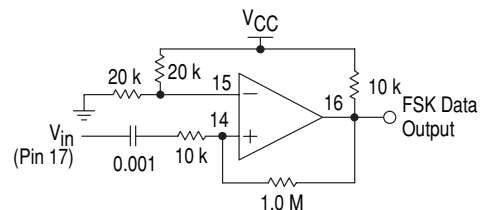

Figure 18. PC Board Solder Side View

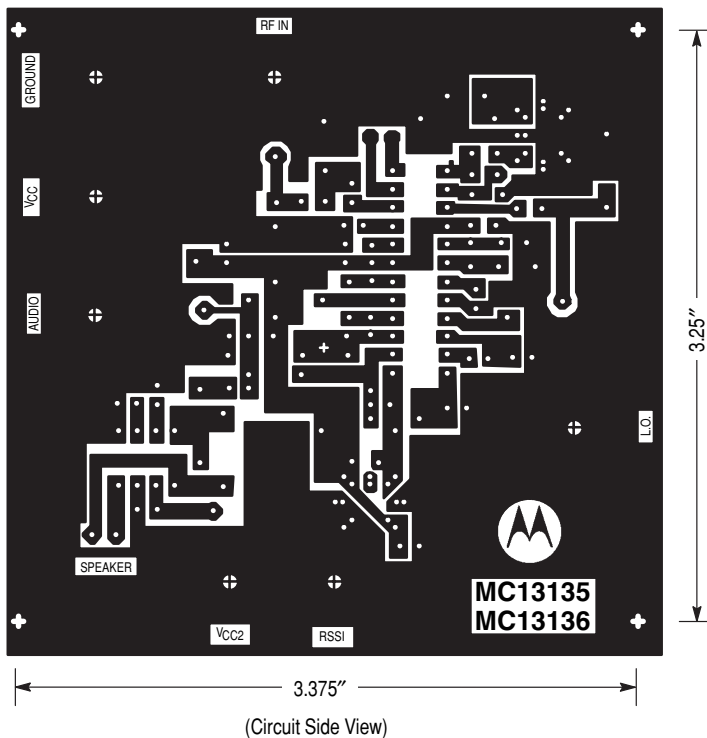
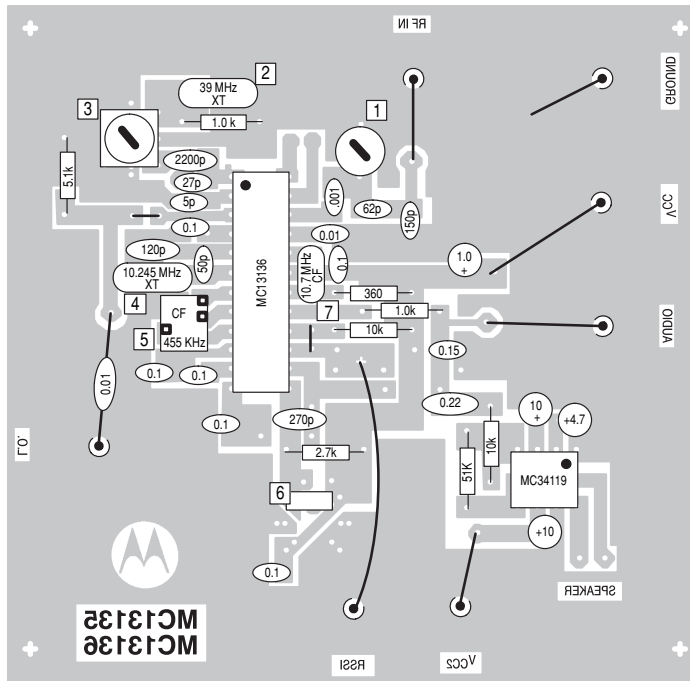
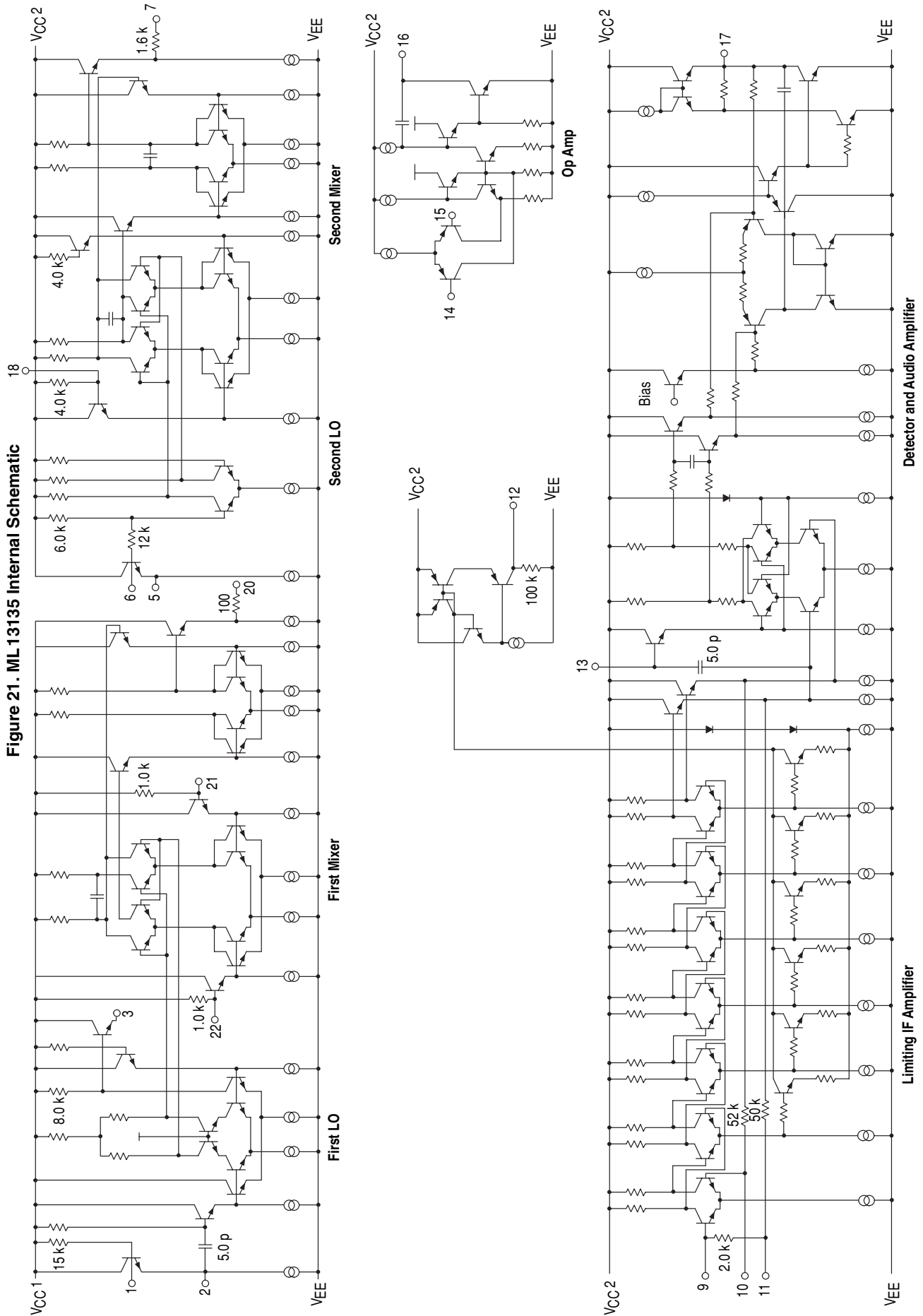

Figure 19. PC Board Component View



- NOTES:**
1. 0.2 μ H tunable (unshielded) inductor
 2. 39 MHz Series mode resonant 3rd Overtone Crystal
 3. 1.5 μ H tunable (shielded) inductor
 4. 10.245 MHz Fundamental mode crystal, 32 pF load
 5. 455 kHz ceramic filter, muRata CFU 455B or equivalent
 6. Ceramic discriminator, muRata CDB455C34 or equivalent
 7. 10.7 MHz ceramic filter, muRata SFE10.7MJ-A or equivalent



This device contains 142 active transistors.

OUTLINE DIMENSIONS

P DIP 24 = LP
 PLASTIC PACKAGE
 (ML13135LP)
 CASE 724-03
 ISSUE D

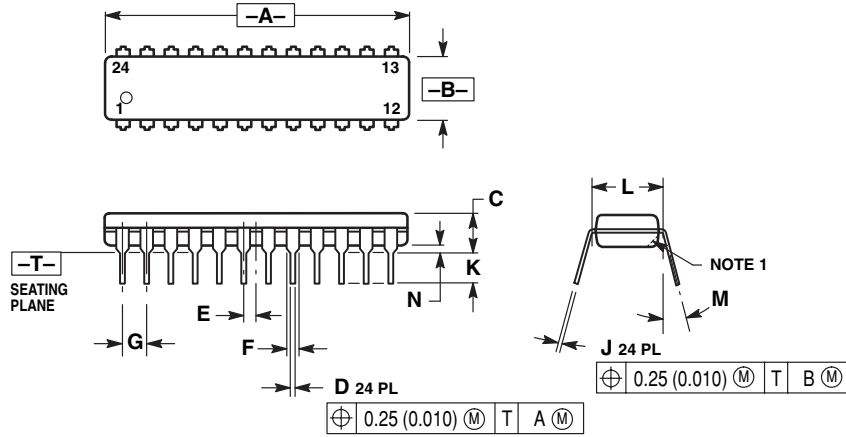

- NOTES:
1. CHAMFERED CONTOUR OPTIONAL.
 2. DIMENSION L TO CENTER OF LEADS WHEN FORMED PARALLEL.
 3. DIMENSIONING AND TOLERANCING PER ANSI Y14.5M, 1982.
 4. CONTROLLING DIMENSION: INCH.

DIM	INCHES		MILLIMETERS	
	MIN	MAX	MIN	MAX
A	1.230	1.265	31.25	32.13
B	0.250	0.270	6.35	6.85
C	0.145	0.175	3.69	4.44
D	0.015	0.020	0.38	0.51
E	0.050 BSC		1.27 BSC	
F	0.040	0.060	1.02	1.52
G	0.100 BSC		2.54 BSC	
J	0.007	0.012	0.18	0.30
K	0.110	0.140	2.80	3.55
L	0.300 BSC		7.62 BSC	
M	0°	15°	0°	15°
N	0.020	0.040	0.51	1.01

SO 24 = -6P
 (ML13135-6P)
 PLASTIC PACKAGE
 CASE 751E-04
 ISSUE E

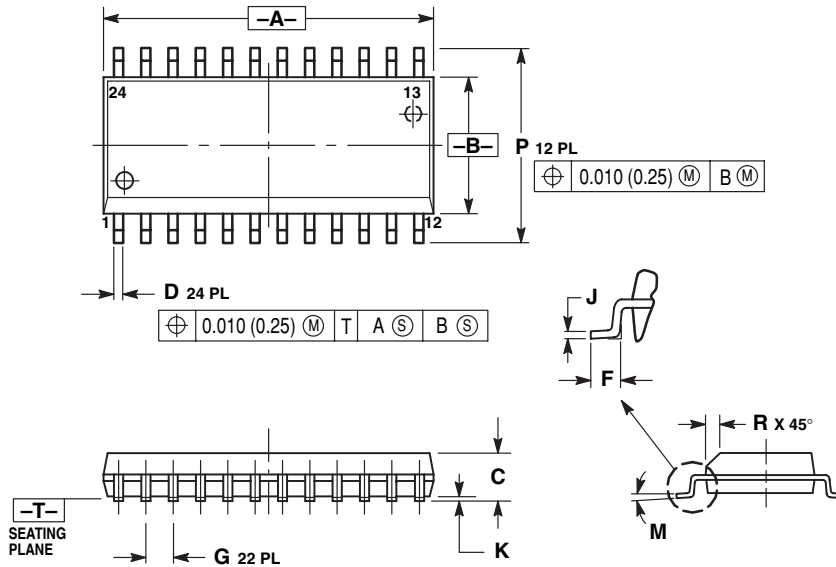

- NOTES:
1. DIMENSIONING AND TOLERANCING PER ANSI Y14.5M, 1982.
 2. CONTROLLING DIMENSION: MILLIMETER.
 3. DIMENSIONS A AND B DO NOT INCLUDE MOLD PROTRUSION.
 4. MAXIMUM MOLD PROTRUSION 0.15 (0.006) PER SIDE.
 5. DIMENSION D DOES NOT INCLUDE DAMBAR PROTRUSION. ALLOWABLE DAMBAR PROTRUSION SHALL BE 0.13 (0.005) TOTAL IN EXCESS OF D DIMENSION AT MAXIMUM MATERIAL CONDITION.

DIM	MILLIMETERS		INCHES	
	MIN	MAX	MIN	MAX
A	15.25	15.54	0.601	0.612
B	7.40	7.60	0.292	0.299
C	2.35	2.65	0.093	0.104
D	0.35	0.49	0.014	0.019
F	0.41	0.90	0.016	0.035
G	1.27 BSC		0.050 BSC	
J	0.23	0.32	0.009	0.013
K	0.13	0.29	0.005	0.011
M	0°	8°	0°	8°
P	10.05	10.55	0.395	0.415
R	0.25	0.75	0.010	0.029

Lansdale Semiconductor reserves the right to make changes without further notice to any products herein to improve reliability, function or design. Lansdale does not assume any liability arising out of the application or use of any product or circuit described herein; neither does it convey any license under its patent rights nor the rights of others. "Typical" parameters which may be provided in Lansdale data sheets and/or specifications can vary in different applications, and actual performance may vary over time. All operating parameters, including "Typicals" must be validated for each customer application by the customer's technical experts. Lansdale Semiconductor is a registered trademark of Lansdale Semiconductor, Inc.