



Z89313

DIGITAL TELEVISION CONTROLLER

FEATURES

- | | | | | |
|----------------------|-------------------|-------------------|--------------------|----------------------------------|
| ■ Part Number | ROM (Word) | RAM (Word) | Speed (MHz) | ■ Direct Closed Caption Decoding |
| Z89313 | 32K x 16 | 1K x 16 | 12 | ■ TV Tuner Serial Interface |
- 52-Pin Shrink DIP Package
 - 4.5- to 5.5-Volt Operating Range
 - Z89C00 RISC Processor Core
 - 0°C to +70°C Temperature Range
 - Customized Character Set
 - Character Control Mode
 - Directly Controlled Receiver Functions

GENERAL DESCRIPTION

The Z89313 is a member of Zilog's family of Digital Television Controllers designed to provide complete audio and video control of television receivers, video recorders, and advanced on-screen display facilities.

The Z89313 features a powerful Z89C00 RISC processor core that controls on-board peripheral functions and registers using the standard processor instruction set.

In closed caption mode, text can be decoded directly from the composite video signal and displayed on the screen with assistance from the processor's digital signal processing capabilities. The character representation in this mode allows for a simple attribute control through the insertion of control characters.

The character control mode provides access to the full set of attribute controls. The modification of attributes is allowed on a character-by-character basis. The insertion of control characters permits direction of other character attributes.

Display attributes, including underlining, italics, blinking, eight foreground/background colors, character position offset delay, and background transparency, are made possible through a fully customized 512 character set, formatted in two 256 character banks.

Serial interfacing with the television tuner is provided through the tuner serial port. Digital channel tuning adjustments may be accessed through the industry-standard I²C port.

Additional hardware provides the capability to display two to three times normal size characters. The smoothing logic contained in the on-screen display circuit improves the appearance of larger fonts. Special circuitry can be activated to improve the visibility of text by adding a right-sided shadow effect to the characters.

Receiver functions such as color and volume can be directly controlled by six 8-bit pulse width modulated ports.

Notes:
All Signals with a preceding front slash, "/", are active Low, e.g.: B//W (WORD is active Low); /B/W (BYTE is active Low, only).

Power connections follow conventional descriptions below:

Connection	Circuit	Device
Power	V _{CC}	V _{DD}
Ground	GND	V _{SS}

GENERAL DESCRIPTION (Continued)

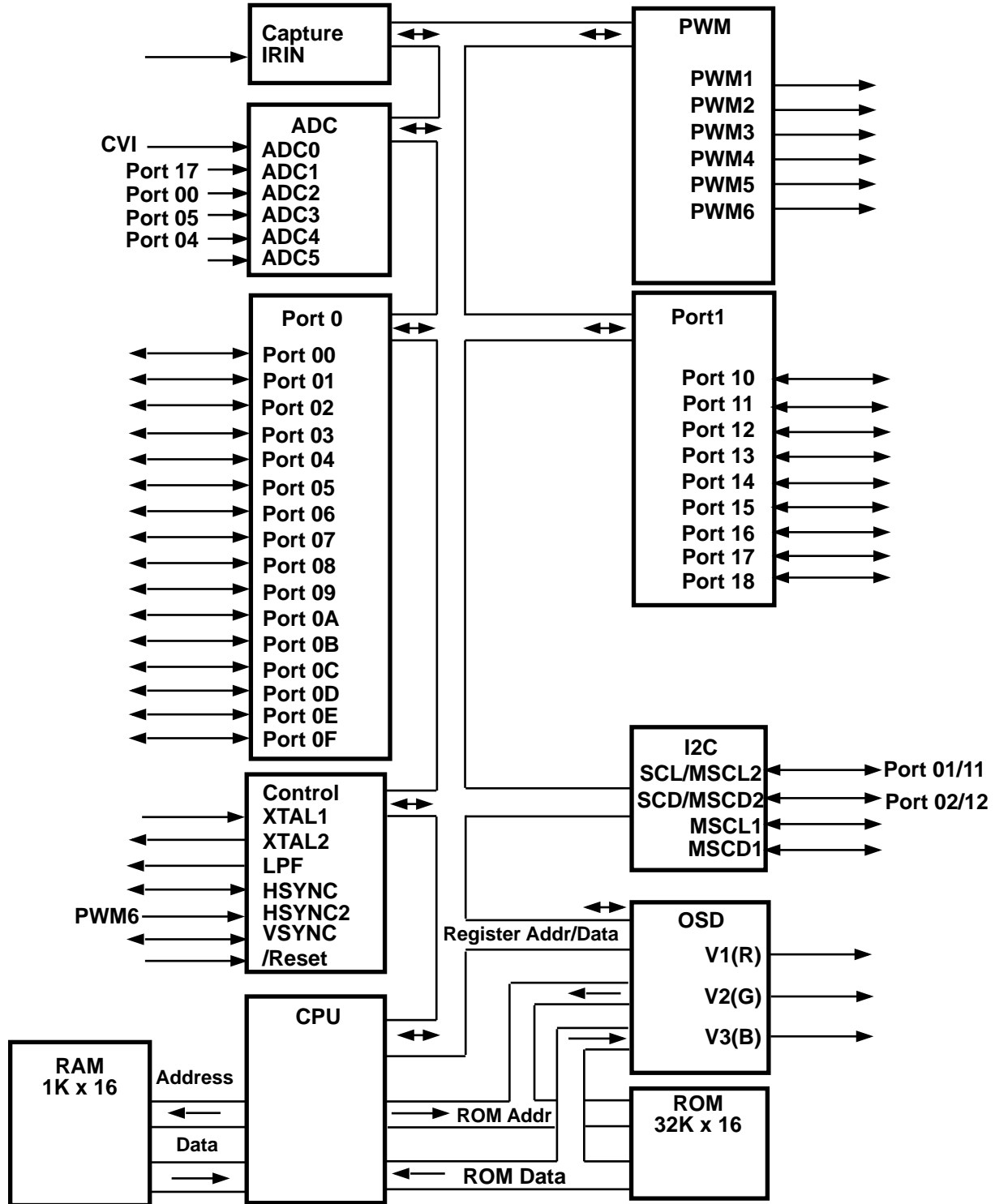

Functional Block Diagram

PIN DESCRIPTION

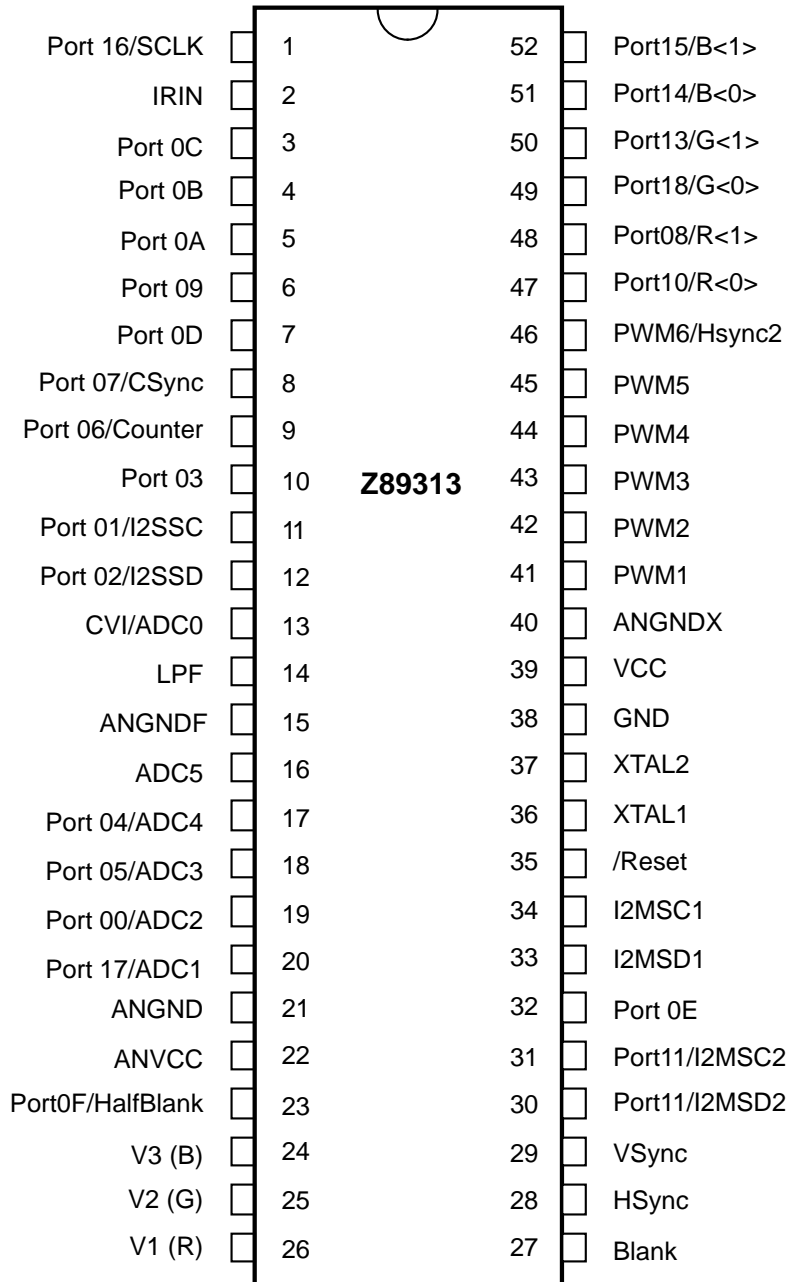

52-Pin Shrink DIP Configuration

PIN DESCRIPTION

Z89313

Pin Name	Function	Z89313 52-Pin	Configuration	
			Direction	Reset
V_{CC} , ANV_{CC} ^a	+5 V	39,22	PWR	–
GND, ANGND, ANGNDF, ANGNDX ^b	0 V	38,21,15,40	PWR	–
IRIN	Infrared Remote Capture Input	2	I	I
ADC[5:1]	4-Bit Analog-to-Digital Converter Input	16,17,18,19,20	AI	I
PWM[6:1]	8-Bit Pulse Width Modulator Output	46,45,44,43,42,41	O	O
Port0[F:0]	Bit Programmable Input/Output Ports	23,32,7,3,4,5,6,48,8,9,18, 17,10,12,11,19	B	I
Port1[8:0]	Bit Programmable Input/Output Ports	49,20,1,52,51,50,30, 31,47	B	I
SCL	I ² C Clock I/O	11,31,34	BOD	
SCD	I ² C Data I/O	12,30,33	BOD	
XTAL1	Crystal Oscillator Input	36	AI	I
XTAL2	Crystal Oscillator Output	37	AO	O
LPF	Loop Filter	14	AB	O
HSYNC	H_Sync	28,46	B	I
VSYNC	V_Sync	29	B	I
/RESET	Device Reset	35	I	I
V[3:1]	OSD Video Output (Typically Drive B, G, and R Outputs)	24,25,26	O	O
Blank	OSD Blank Output	27	O	O
Half Blank	OSD Half Blank Output	23	O	
SCLK	Internal Processor SCLK	–	O	

Notes:

Please refer to pin-out diagram for shared pin numbers.

a) ANV_{CC} is for the reference voltage of the ADC input.

b) ANGND is for the reference ground of the ADC input.

ANGNDF is for LPF ground, and ANGNDX is for XTAL circuit ground.

V1, V2, V3 ANALOG OUTPUT

Specifications $V_{CC} = 5.25\text{ V}$

$V_{CC} = 5.25\text{ V}$	Condition	Limit
Output Voltage	Bit = 11	$4.30\text{ V} \pm 0.3\text{ V}$
	Bit = 10	$3.10\text{ V} \pm 0.25\text{ V}$
	Bit = 01	$1.90\text{ V} \pm 0.20\text{ V}$
	Bit = 00	$0\text{ V} \pm 0.75\text{ V}$
Setting Time	70% of DC Level, 10pf Load	< 50 ns

V1, V2, V3 ANALOG OUTPUT

Specifications $V_{CC} = 4.75\text{ V}$

$V_{CC} = 4.75\text{ V}$	Condition	Limit
Output Voltage	Bit = 11	$3.90\text{ V} \pm 0.30\text{ V}$
	Bit = 10	$2.80\text{ V} \pm 0.25\text{ V}$
	Bit = 01	$1.70\text{ V} \pm 0.20\text{ V}$
	Bit = 00	$0\text{ V} \pm 0.65\text{ V}$
Setting Time	70% of DC Level, 10pf Load	< 50 ns

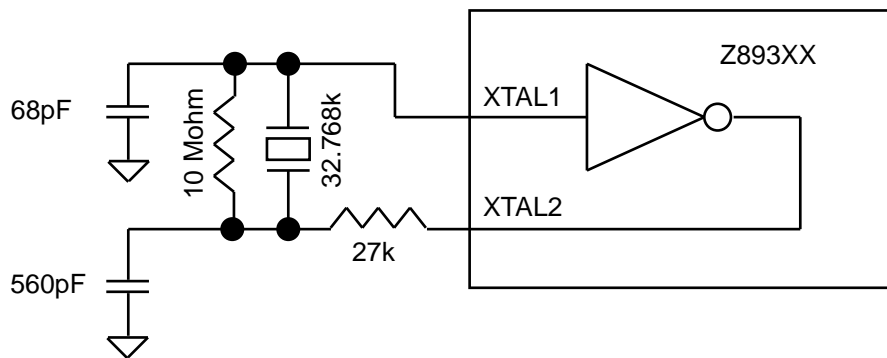

32K Oscillator Recommended Circuit

ABSOLUTE MAXIMUM RATINGS

Symbol	Parameter	Min	Max	Units	Conditions
V_{CC}	Power Supply Voltage	0	7	V	
V_{ID}	Input Voltage	-0.3	$V_{CC} + 0.3$	V	Digital Inputs
V_{IA}	Input Voltage	-0.3	$V_{CC} + 0.3$	V	Analog Inputs (A/D0...A/D4)
V_O	Output Voltage	-0.3	$V_{CC} + 0.3$	V	All Push-Pull Digital Output
I_{OH}	Output Current High		-10/-1 ^a	mA	One Pin
I_{OH}	Output Current High		-100	mA	All Pins
I_{OL}	Output Current Low		20/1 ^b	mA	One Pin
I_{OL}	Output Current Low		200	mA	All Pins
T_A	Operating Temperature	0	70	°C	
T_A	Storage Temperature	-65	150	°C	

Notes:

- a) 1 mA max. when output pad impedance is 600 Ω .
 b) 1 mA max. when output pad impedance is 600 Ω .

DC CHARACTERISTICS

$T_A = 0^\circ\text{C}$ to $+70^\circ\text{C}$; $V_{CC} = 4.5\text{ V}$ to $+5.5\text{ V}$; $F_{OSC} = 32.768\text{ KHz}$

Symbol	Parameter	Min	Max	Typical	Units	Conditions
V_{IL}	Input Voltage Low	0	$0.2 V_{CC}$	0.4	V	
V_{IH}	Input Voltage High	$0.6 V_{CC}$	V_{CC}	3.6	V	
V_{OL}	Output Voltage Low		0.4	0.16	V	@ $I_{OL} = 1\text{ mA}$
V_{OH}	Output Voltage High	$V_{CC} - 0.9$		4.75	V	@ $I_{OL} = 0.75\text{ mA}$
V_{XL}	Input Voltage XTAL1 Low		$0.3 V_{CC}$	1.0	V	External Clock
V_{XH}	Input Voltage XTAL1 High	$V_{CC} - 2.0$		3.5	V	Generator Driven
V_{HY}	Schmitt Hysteresis	3.0	0.75	0.5	V	On XTAL1 Input Pin
I_{IR}	Reset Input Current		150	90	μA	$V_{RL} = 0\text{ V}$
I_{IL}	Input Leakage	-3.0	3.0	0.01	μA	@ 0 V and V_{CC}
I_{CC}	Supply Current		100	60	mA	
I_{CC1}	Supply Current		300	100	μA	Sleep Mode @ 32 KHz
I_{CC2}	Supply Current		40	5	μA	Stop Mode

AC CHARACTERISTICS

$T_A = 0^\circ\text{C to } +70^\circ\text{C}; V_{CC} = 4.5 \text{ V to } 5.5 \text{ V}; F_{OSC} = 32.768 \text{ KHz}$

Symbol	Parameter	Min	Max	Typical	Units	Note
T_{PC}	Input Clock Period	16	100	32	μS	
T_{RC}, T_{FC}	Clock Input Rise and Fall			12	μS	
T_{DPOR}	Power On Reset Delay	0.8		1.2	s	Depends on Crystal

AC CHARACTERISTICS*

$T_A = 0^\circ\text{C to } +70^\circ\text{C}; V_{CC} = 4.5 \text{ V to } 5.5 \text{ V}; F_{OSC} = 32.768 \text{ KHz}$

Symbol	Parameter	Min	Max	Typical	Units
T_{WRES}	Power-On Reset Min. Width		5TPC		μS
T_{DH_S}	H_Sync Incoming Signal Width	5.5	12.5	11	μS
T_{DV_S}	V_Sync Incoming Signal Width	0.15	1.5	1.0	mS
T_{DE_S}	Time Delay Between Leading Edge of V_Sync and H_Sync in Even Field	-12	+12	0	μS
T_{DO_S}	Time Delay Between Leading Edge of H_Sync in Odd Field	20	44	32	μS
T_{WHV_S}	H_Sync/V_Sync Edge Width		2.0	0.5	μS

Notes:

All timing of the I²C bus interface are defined by related specifications of the I²C bus interface.

Pre-Characterization Product:

The product represented by this CPS is newly introduced and Zilog has not completed the full characterization of the product. The CPS states what Zilog knows about this product at this time, but additional features or non-con-

formance with some aspects of the CPS may be found, either by Zilog or its customers in the course of further application and characterization work. In addition, Zilog cautions that delivery may be uncertain at times, due to start-up yield issues.

© 1995 by Zilog, Inc. All rights reserved. No part of this document may be copied or reproduced in any form or by any means without the prior written consent of Zilog, Inc. The information in this document is subject to change without notice. Devices sold by Zilog, Inc. are covered by warranty and patent indemnification provisions appearing in Zilog, Inc. Terms and Conditions of Sale only. Zilog, Inc. makes no warranty, express, statutory, implied or by description, regarding the information set forth herein or regarding the freedom of the described devices from intellectual property infringement. Zilog, Inc. makes no warranty of merchantability or fitness for any purpose. Zilog, Inc. shall not be responsible for any errors that may appear in this document. Zilog, Inc. makes no commitment to update or keep current the information contained in this document.

Zilog's products are not authorized for use as critical components in life support devices or systems unless a specific written agreement pertaining to such intended use is executed between the customer and Zilog prior to use. Life support devices or systems are those which are intended for surgical implantation into the body, or which sustains life whose failure to perform, when properly used in accordance with instructions for use provided in the labeling, can be reasonably expected to result in significant injury to the user.

Zilog, Inc. 210 East Hacienda Ave.
Campbell, CA 95008-6600
Telephone (408) 370-8000
Telex 910-338-7621
FAX 408 370-8056
Internet: <http://www.zilog.com>