

FEATURES

- 200ns Maximum acquisition time
- ±0.01% Accuracy
- 100ns Maximum sample-hold settling time
- 74dB Feedthrough attenuation
- ±50ps Aperture uncertainty
- Industry standard



GENERAL DESCRIPTION

DATEL's SHM-4860 is a high-speed, highly accurate sample-hold amplifier designed for precision, high-speed analog signal processing applications. Manufactured using modern, high-quality hybrid technology, the SHM-4860 features excellent dynamic specifications including a maximum acquisition time of only 200ns for a 10V step to ±0.01%. Sample-to-hold settling time, to ±0.01% accuracy, is 100ns maximum with an aperture uncertainty of ±50ps.

The SHM-4860 is a complete sample-hold circuit, containing a precision MOS hold capacitor and a MOSFET switching configuration which results in faster switching and better feedthrough attenuation. Additionally, a FET-input amplifier design allows faster acquisition and settling times while maintaining a considerably lower droop rate.

INPUT/OUTPUT CONNECTIONS

PIN	FUNCTION	PIN	FUNCTION
1	OUTPUT	24	+15V SUPPLY
2	N.C.	23	GROUND
3	N.C.	22	-15V SUPPLY
4	N.C.	21	GROUND
5	N.C.	20	N.C.
6	N.C.	19	N.C.
7	N.C.	18	N.C.
8	N.C.	17	N.C.
9	+5V SUPPLY	16	N.C.
10	GROUND	15	GROUND
11	HOLD COMMAND	14	N.C.
12	HOLD COMMAND	13	INPUT

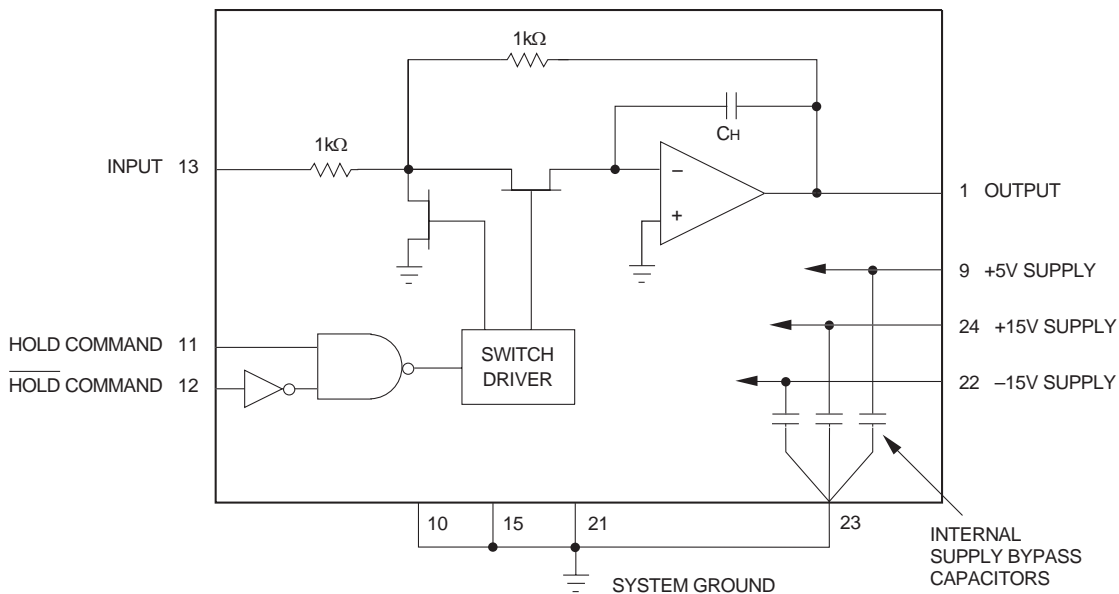

Figure 1. Functional Block Diagram

ABSOLUTE MAXIMUM RATINGS

±15V Supply Voltages, Pins 24, 22	±18V
+5V Supply Voltage, Pin 9	-0.5V to +7V
Analog Input, Pin 13 ①	±18V
Digital Inputs, Pins 11, 12	-0.5V to +7V
Output Current ②	±65mA

FUNCTIONAL SPECIFICATIONS

(Typical at +25°C with ±15V and +5V supplies unless otherwise noted.)

ANALOG INPUT/OUTPUT	MIN.	TYP.	MAX.	UNITS
Input/Output Voltage Range ①	±10.25	±11.25	—	V
Input Impedance	—	1	—	kΩ
Output Current ②	—	—	±40	mA
Output Impedance	—	0.1	—	kΩ
Maximum Capacitive Load	—	250	—	pF
DIGITAL INPUT				
Input Logic Level				
Logic "1"	+2.0	—	+5.0	V
Logic "0"	0	—	+0.8	V
Loading				
Logic "1"	—	—	+40	μA
Logic "0"	—	—	-1.6	mA
TRANSFER CHARACTERISTICS				
Gain	—	-1	—	V/V
Gain Accuracy	—	±0.05	±0.1	%
Gain Linearity Error ③	—	±0.005	±0.01	%FS
Sample-Mode Offset Voltage	—	±0.5	±5	mV
Sample-to-Hold Offset Error ④ (Pedestal)	—	±2.5	±20	mV
Gain Tempco (Drift)	—	±0.5	±5	ppm/°C
Sample-Mode Offset Drift	—	±3	±15	⑤
Sample-to-Hold Offset Drift	—	±4	—	⑤
DYNAMIC CHARACTERISTICS				
Acquisition Time				
10V to ±0.01%FS	—	160	200	ns
10V to ±0.1%FS	—	100	170	ns
10V to ±1%FS	—	90	—	ns
1V to ±1%FS	—	75	—	ns
Sample-to-Hold Settling Time				
10V to ±0.01%FS	—	60	100	ns
10V to ±0.1%FS	—	40	—	ns
Sample-to-Hold Transient	—	180	—	mV p-p
Aperture Delay Time	—	6	—	ns
Aperture Uncertainty (Jitter)	—	±50	—	ps
Output Slew Rate	—	±300	—	μV/μs
Small Signal Bandwidth (-3dB)	—	16	—	MHz
Droop: +25°C	—	±0.5	±5	μV/μs
+70°C	—	±15	—	μV/μs
+125°C	—	±1.2	—	mV/μs
Feedthrough Attenuation	—	74	—	dB
Overload Recovery Time				
Positive	—	200	—	ns
Negative	—	700	—	ns
POWER REQUIREMENTS				
Voltage Range: ±15V Supplies	—	±3	—	%
+5V Supply	—	±5	—	%
Power Supply Rejection Ratio	—	±0.5	—	mV/V
Quiescent Current Drain				
+15V Supply	—	+21	+25	mA
-15V Supply	—	-22	-25	mA
+5V Supply	—	+17	+25	mA
Power Consumption	—	730	875	mW

PHYSICAL/ENVIRONMENTAL

Operating Temperature Ranges	
SHM-4860MC	0 to +70°C (ambient)
SHM-4860MM, 883	-55 to +125°C (case)
Storage Temperature Range	-65 to +150°C
Package Type	24-pin ceramic DDIP

Footnotes:

- ① Input signal should not exceed the supply voltage.
- ② The SHM-4860's output is current limited at approximately ±65mA. The device can withstand a sustained short to ground. However, shorts from the output to either supply will cause permanent damage. For normal operation, the load current should not exceed ±40mA.
- ③ Full Scale (FS) = 10V. Full Scale Range (FSR) = 20V.
- ④ Sample-to-Hold Offset Error (Pedestal) is constant regardless of input/output level.
- ⑤ Units are ppm of FSR/°C.

TECHNICAL NOTES

1. All ground pins (10, 15, 21, 23) should be tied together and connected to system analog ground as close to the package as possible. It is recommended to use a ground plane under the device and solder all four ground pins directly to it. Care must be taken to ensure that no ground potentials can exist between Pin 10 and the other ground pins.
2. Although the power supply pins (9, 22, 24) are internally bypassed to ground with 0.01μF ceramic capacitors, additional external 0.1μF to 1μF tantalum bypass capacitors may be required in critical applications.
3. A logic "0" on the HOLD COMMAND input (Pin 11), or a logic "1" on the $\overline{\text{HOLD}}$ COMMAND input (Pin 12), will put the device in the sample mode. In this mode, the device acts as an inverting unity-gain amplifier, and its output will track its input. A logic "1" on Pin 11 (logic "0" on Pin 12) will put the device in the hold mode, and the output will be held constant at the last input level present when the hold command was given.

If the HOLD COMMAND input (Pin 11) is used to control the device, Pin 12 must be tied to digital ground. If $\overline{\text{HOLD}}$ COMMAND input (Pin 12) is used to control the device, Pin 11 must be tied to +5V.
4. The maximum capacitive load to avoid oscillation is typically 250pF. Recommended resistive load is 500Ω, although values as low as 250Ω may be used. Acquisition and sample-to-hold settling times are relatively unaffected by resistive loads down to 250Ω and capacitive loads up to 50pF. However, higher capacitances will affect both acquisition and settling time.

MECHANICAL DIMENSIONS
INCHES (mm)

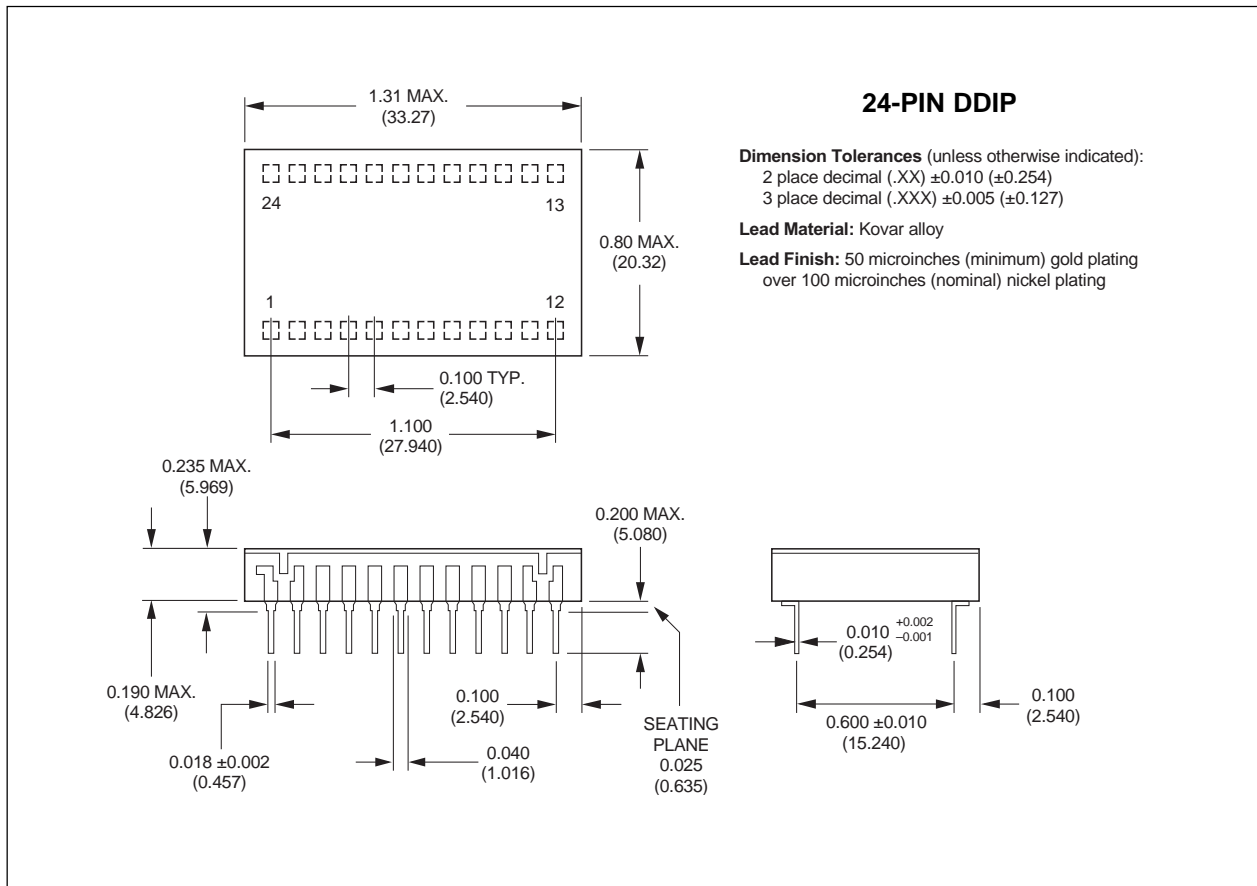

ORDERING INFORMATION

MODEL NUMBER	OPERATING TEMP. RANGE
SHM-4860MC	0 to +70°C
SHM-4860MM	-55 to +125°C
SHM-4860/883	-55 to +125°C

Contact DATEL for 883 product specifications.

DS-0088A 1996

DATEL, Inc. 11 Cabot Boulevard, Mansfield, MA 02048-1151
 Tel: (508) 339-3000 (800) 233-2765 Fax: (508) 339-6356
 Internet: www.datel.com Email: sales@datel.com

DATEL (UK) LTD. Tadley, England Tel: (01256)-880444
 DATEL S.A.R.L. Montigny Le Bretonneux, France Tel: 01-34-60-01-01
 DATEL GmbH München, Germany Tel: 89-544334-0
 DATEL KK Tokyo, Japan Tel: 3-3779-1031, Osaka Tel: 6-6354-2025

DATEL makes no representation that the use of its products in the circuits described herein, or the use of other technical information contained herein, will not infringe upon existing or future patent rights. The descriptions contained herein do not imply the granting of licenses to make, use, or sell equipment constructed in accordance therewith. Specifications are subject to change without notice. The DATEL logo is a registered DATEL, Inc. trademark.