HN624316 Series

High Speed 1048576-word \times 16-bit / 2097152-word \times 8-bit
CMOS Mask Programmable Read only Memory

HITACHI

Rev. 0.0
Dec. 1, 1995

Description

The HN624316 is a 16-Mbit CMOS mask-programmable ROM organized either as 1048576 words by 16 bits or as 2097152 words by 8 bits. Realizing low power consumption, this memory is allowed for battery operation. And a high speed access of 120/150 ns is the most suitable to the system using a high speed microcomputer by 16 bits as 8086 and 68000 e.t.c..

Features

- Single +5 V power supply
- Maximum access time: 120/150 ns (max)
- Low power consumption: 300 mW (typ) active
5 μ W (typ) standby
- Byte-wide or word-wide data organization with BHE

Ordering Information

Type No.	Access Time	Package
HN624316P-12	120 ns	600 mil 42-pin plastic DIP (DP-42)
HN624316P-15	150 ns	
HN624316FB-12	120 ns	44-pin plastic SOP (FP-44D)
HN624316FB-15	150 ns	

Block Diagram

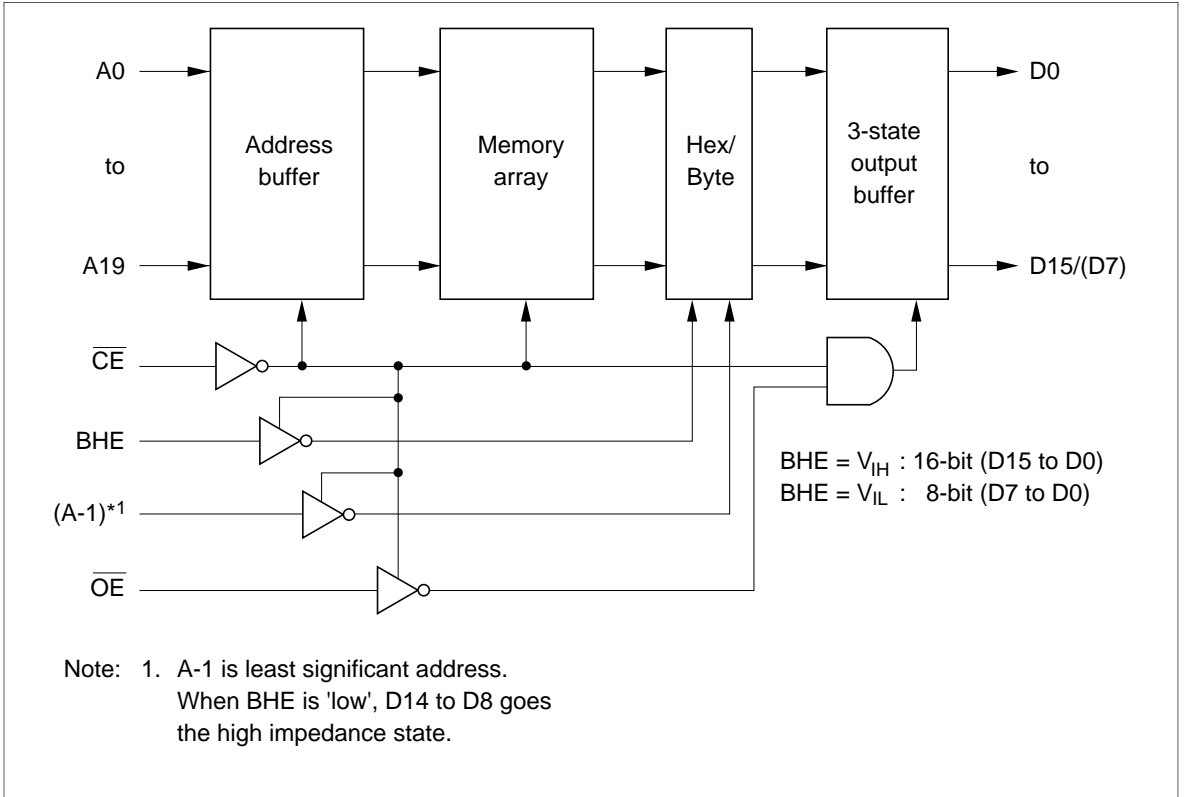

Pin Arrangement

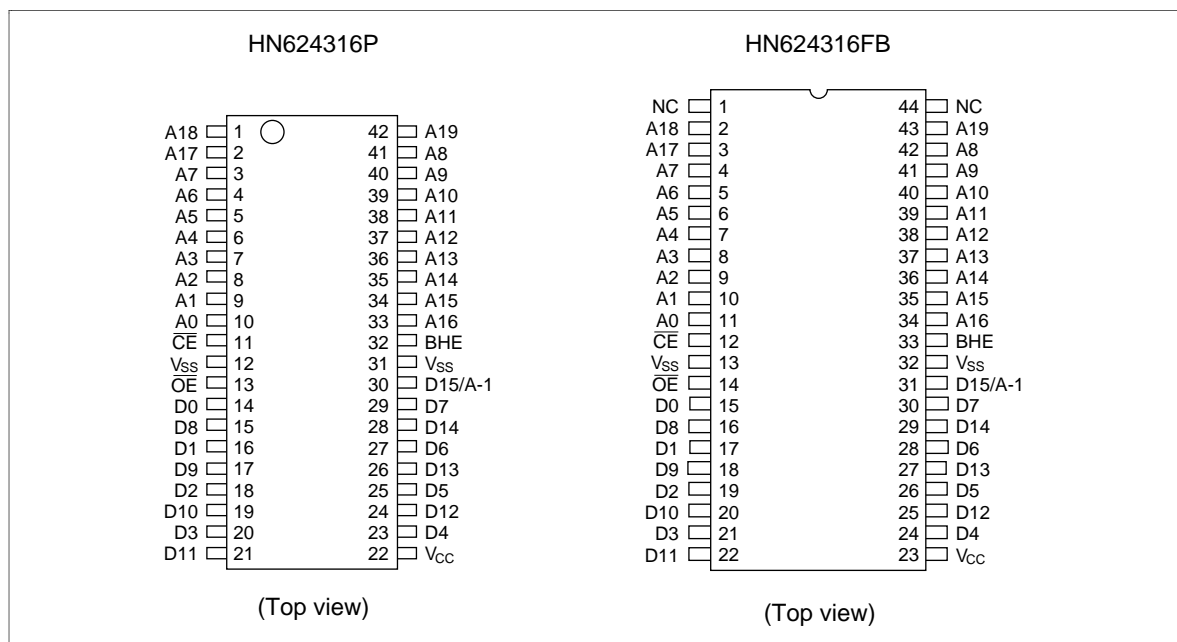

Absolute Maximum Ratings

Parameter	Symbol	Value	Unit	Note
Supply voltage	V_{CC}	-0.3 to +7.0	V	1
All input and output voltage	V_{in}, V_{out}	-0.3 to $V_{CC} + 0.3$	V	1
Operating temperature range	T_{opr}	0 to +70	°C	
Storage temperature range	T_{stg}	-55 to +125	°C	
Temperature under bias	T_{bias}	-20 to +85	°C	

Note: 1. With respect to V_{SS} .

Recommended DC Operating Conditions ($V_{SS} = 0$ V, $T_a = 0$ to +70°C)

Parameter	Symbol	Min	Typ	Max	Unit
Supply voltage	V_{CC}	4.5	5.0	5.5	V
Input voltage	V_{IH}	2.2	—	$V_{CC} + 0.3$	V
	V_{IL}	-0.3	—	0.8	V

HN624316 Series

DC Characteristics ($V_{CC} = 5\text{ V} \pm 10\%$, $V_{SS} = 0\text{ V}$, $T_a = 0\text{ to }+70^\circ\text{C}$)

Parameter		Symbol	Min	Max	Unit	Test Conditions
Supply current	Active	I_{CC}	—	90/80	mA	$V_{CC} = 5.5\text{ V}$, $I_{DOUT} = 0\text{ mA}$, $t_{RC} = 120\text{ ns}/150\text{ ns}$
	Standby	I_{SB1}	—	30	μA	$V_{CC} = 5.5\text{ V}$, $\overline{CE} \geq V_{CC} - 0.2\text{ V}$
	Standby	I_{SB2}	—	3	mA	$V_{CC} = 5.5\text{ V}$, $\overline{CE} \geq 2.2\text{ V}$
Input leakage current		$ I_{IL} $	—	10	μA	$V_{IN} = 0\text{ to }V_{CC}$
Output leakage current		$ I_{OL} $	—	10	μA	$\overline{CE} = 2.2\text{ V}$, $V_{OUT} = 0\text{ to }V_{CC}$
Output voltage		V_{OH}	2.4	—	V	$I_{OH} = -205\text{ }\mu\text{A}$
		V_{OL}	—	0.4	V	$I_{OL} = 1.6\text{ mA}$

Capacitance ($V_{CC} = 5\text{ V} \pm 10\%$, $V_{SS} = 0\text{ V}$, $T_a = 25^\circ\text{C}$, $V_{IN} = 0\text{ V}$, $f = 1\text{ MHz}$)

Parameter		Symbol	Min	Max	Unit
Input capacitance		C_{in}	—	15	pF
Output capacitance		C_{out}	—	15	pF

Note: This parameter is sampled and not 100% tested.

AC Characteristics ($V_{CC} = 5\text{ V} \pm 10\%$, $V_{SS} = 0\text{ V}$, $T_a = 0\text{ to }+70^\circ\text{C}$)

- Output load: $1\text{TTLgate} + C_L = 100\text{ pF}$
(including jig capacitance)
- Input pulse level: 0.45 to 2.4 V
- Input and output timing reference level: 1.5 V
- Input rise and fall time: 5 ns

Parameter	Symbol	HN624316-12		HN624316-15		Unit
		Min	Max	Min	Max	
Read cycle time	t_{RC}	120	—	150	—	ns
Address access time	t_{AA}	—	120	—	150	ns
\overline{CE} access time	t_{ACE}	—	120	—	150	ns
\overline{OE} access time	t_{OE}	—	55	—	70	ns
BHE access time	t_{BHE}	—	120	—	150	ns
Output hold time from address change	t_{DHA}	0	—	0	—	ns
Output hold time from \overline{CE}	t_{DHC}	0	—	0	—	ns
Output hold time from \overline{OE}	t_{DHO}	0	—	0	—	ns
Output hold time from BHE	t_{DHB}	0	—	0	—	ns
\overline{CE} to output in high-Z	t_{CHZ}^{*1}	—	40	—	70	ns
\overline{OE} to output in high-Z	t_{OHZ}^{*1}	—	40	—	70	ns
BHE to output in high-Z	t_{BHZ}^{*1}	—	40	—	70	ns
\overline{CE} to output in low-Z	t_{CLZ}	5	—	5	—	ns
\overline{OE} to output in low-Z	t_{OLZ}	5	—	5	—	ns
BHE to output in low-Z	t_{BLZ}	5	—	5	—	ns

Note: 1. t_{CHZ} and t_{OHZ} and t_{BHZ} are defined as the time at which the output achieves the open circuit conditions and are not referred to output voltage levels..

Timing Waveforms

Word Mode (BHE = 'V_{IH}') or Byte Mode (BHE = 'V_{IL}')

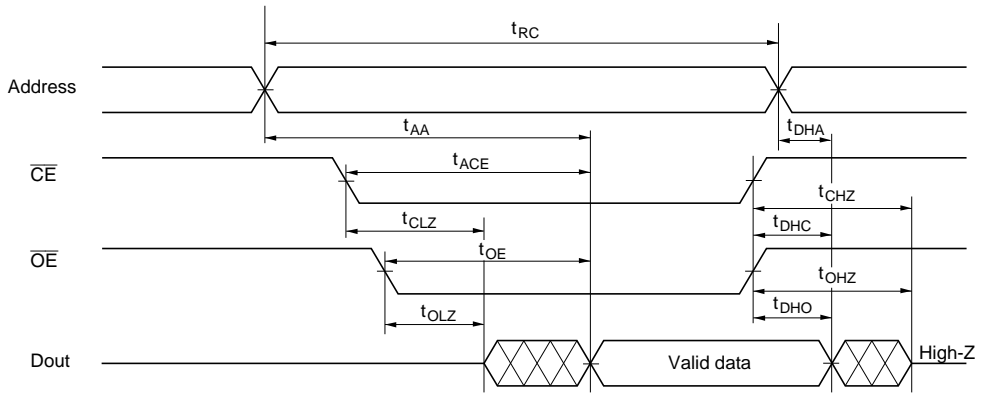

- Notes: 1. t_{DHA} , t_{DHC} , t_{DHO} : Determined by faster.
 2. t_{AA} , t_{ACE} , t_{OE} : Determined by slower.
 3. t_{CLZ} , t_{OLZ} : Determined by slower.

Word Mode, Byte Mode Switch

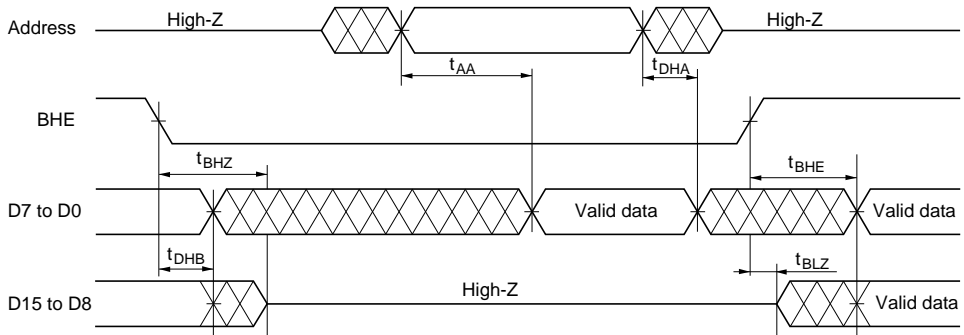

- Notes: 1. \overline{CE} and \overline{OE} are enable A19 to A0 are valid.
 2. D15/A-1 pin is in the output state when BHE is high, \overline{CE} and \overline{OE} are enable.
 Therefore, the input signals of opposite phase to the output must not be applied to them.

Power Up Sequence

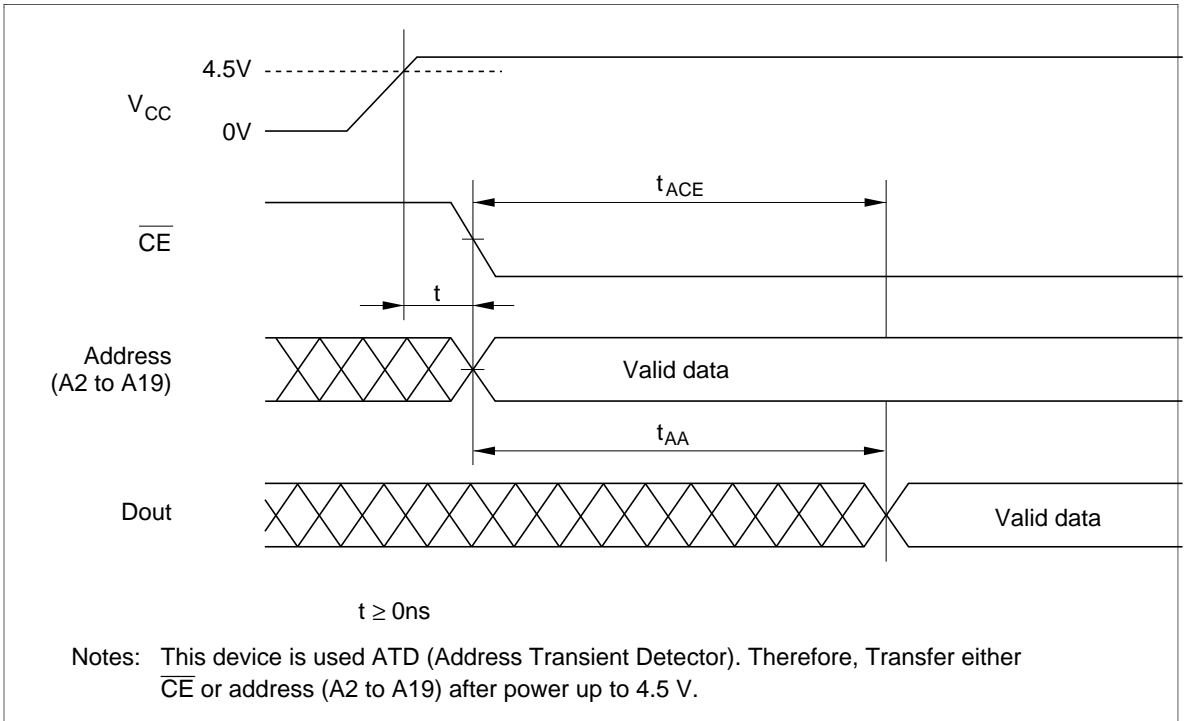

HN624316 Series

Package Information

HN624316P Series (DP-42)

Unit: mm

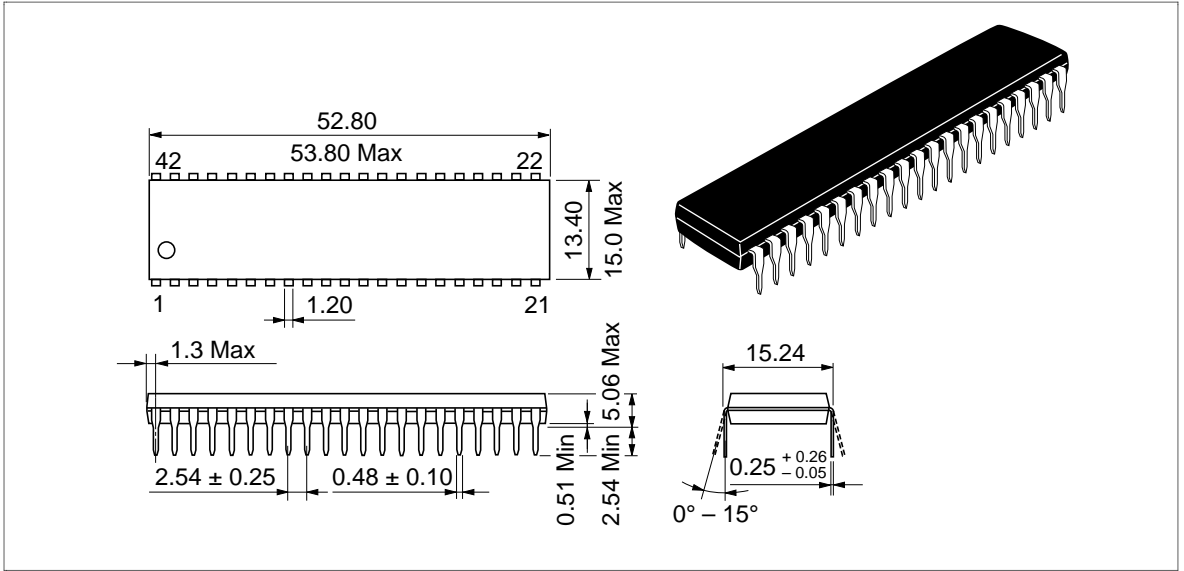

HN624316FB Series (FP-44D)

Unit: mm

