

24 Bit Stereo ADC

DESCRIPTION

The WM8738 is a high performance stereo audio ADC designed for consumer applications.

Stereo line-level audio inputs are provided, along with a control input pin to allow operation of the audio interface in either one of two industry standard modes. The device also has a selectable digital high pass filter to remove residual DC offsets.

Stereo 24-bit multi-bit sigma delta ADCs are provided, along with oversampling digital interpolation filters. 24-bit digital audio output word lengths and sampling rates from 32kHz to 96kHz are supported.

The device is available in a small 14-lead SOIC package.

FEATURES

- Audio Performance
 - 90 dB SNR ('A' weighted @ 48kHz)
- 3.0 – 5.5V Analogue Supply Operation
- 3.0 – 3.6V Digital Supply Operation
- ADC Sampling Frequency: 32kHz – 96kHz
- Selectable ADC High Pass Filter
- Selectable Audio Data Interface Modes
 - I²S or Left Justified
- 14-lead SOIC Package

APPLICATIONS

- CD and Minidisc Recorders
- DVD Players
- General Purpose Audio Conversion

BLOCK DIAGRAM

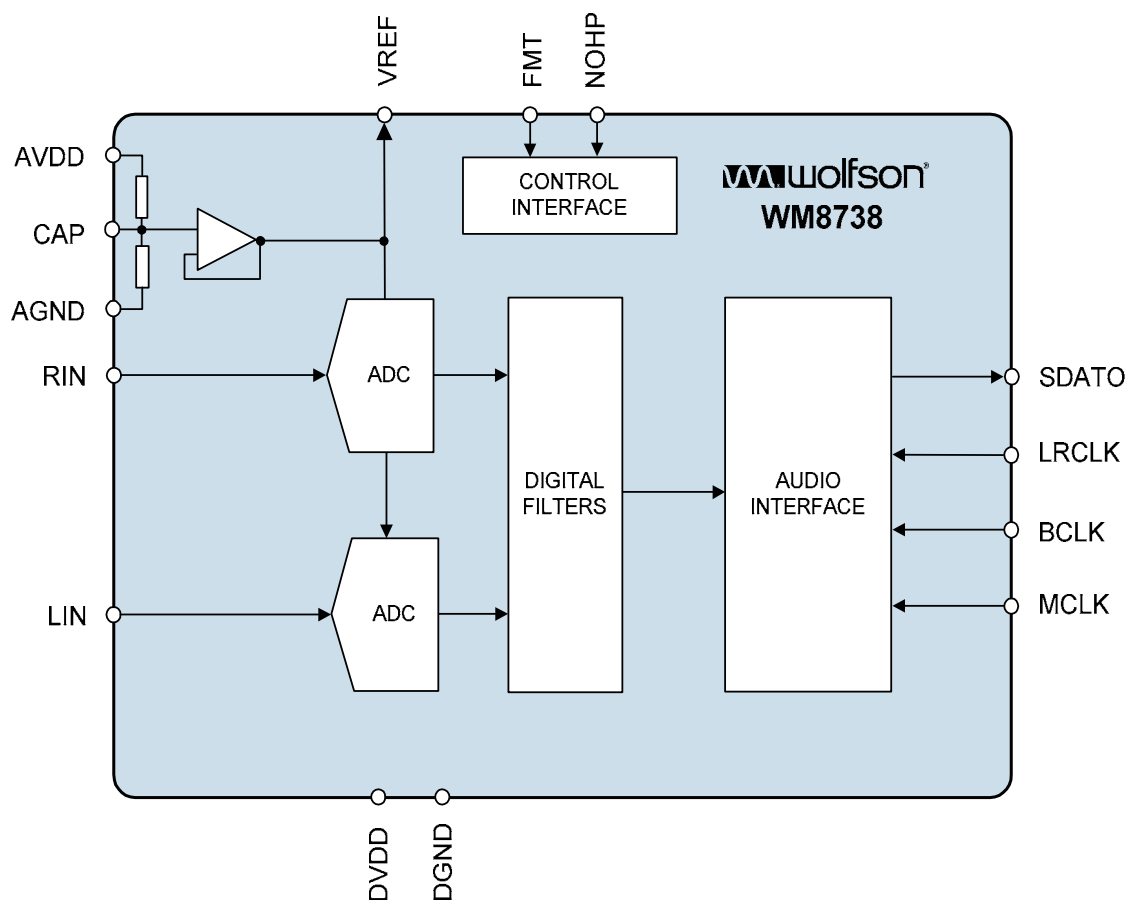
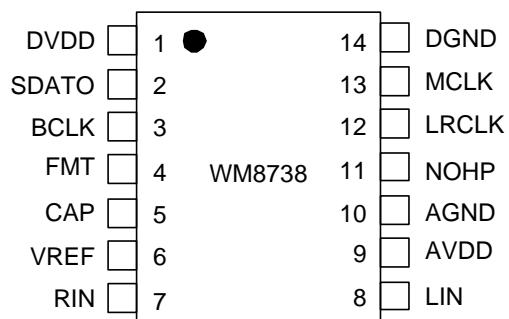

TABLE OF CONTENTS

DESCRIPTION	1
FEATURES.....	1
APPLICATIONS	1
BLOCK DIAGRAM	1
TABLE OF CONTENTS	2
PIN CONFIGURATION.....	3
ORDERING INFORMATION	3
PIN DESCRIPTION	4
ABSOLUTE MAXIMUM RATINGS.....	5
RECOMMENDED OPERATING CONDITIONS	5
ELECTRICAL CHARACTERISTICS	6
TERMINOLOGY	7
DIGITAL AUDIO INTERFACE TIMING	8
INTERNAL POWER ON RESET CIRCUIT	9
DEVICE DESCRIPTION	12
INTRODUCTION.....	12
ADC.....	12
ADC DIGITAL FILTER.....	12
AUDIO DATA SAMPLING RATES.....	13
DIGITAL AUDIO INTERFACES.....	14
DIGITAL FILTER CHARACTERISTICS	15
ADC FILTER RESPONSES	15
ADC HIGH PASS FILTER	15
APPLICATIONS INFORMATION	16
RECOMMENDED EXTERNAL COMPONENTS.....	16
RECOMMENDED EXTERNAL COMPONENTS VALUES.....	16
PACKAGE DIMENSIONS	17
IMPORTANT NOTICE	18
ADDRESS:.....	18

PIN CONFIGURATION



ORDERING INFORMATION

DEVICE	TEMPERATURE RANGE	PACKAGE	MOISTURE SENSITIVITY LEVEL	PEAK SOLDERING TEMPERATURE
WM8738GED/V	-25 to +85°C	14-lead SOIC (Pb-free)	MSL2	260°C
WM8738GED/RV	-25 to +85°C	14-lead SOIC (Pb-free, tape and reel)	MSL2	260°C

Note:

Reel quantity = 3,000

PIN DESCRIPTION

PIN	NAME	TYPE	DESCRIPTION
1	DVDD	Supply	Digital positive supply
2	SDATO	Digital Output	ADC digital data output
3	BCLK	Digital Input	ADC audio interface data clock (5V tolerant)
4	FMT	Digital input (with pull down)	Audio interface format selection (5V tolerant) '0' = I ² S '1' = Left Justified
5	CAP	Analog	Reference de-coupling pin
6	VREF	Analogue output	Buffered reference decoupling pin
7	RIN	Analogue Input	Right channel ADC input
8	LIN	Analogue Input	Left channel ADC input
9	AVDD	Supply	Analogue positive supply
10	AGND	Supply	Analogue ground supply and chip substrate
11	NOHP	Digital input (with pull down)	Digital highpass filter bypass; (5V tolerant) '0' = Enabled '1' = Bypassed
12	LRCLK	Digital Input	Data left/right word clock (5V tolerant)
13	MCLK	Digital Input	Master clock input (5V tolerant)
14	DGND	Supply	Digital supply ground

Notes

1. Digital input pins have Schmitt trigger input buffers and are 5V tolerant.

ABSOLUTE MAXIMUM RATINGS

Absolute Maximum Ratings are stress ratings only. Permanent damage to the device may be caused by continuously operating at or beyond these limits. Device functional operating limits and guaranteed performance specifications are given under Electrical Characteristics at the test conditions specified.



ESD Sensitive Device. This device is manufactured on a CMOS process. It is therefore generically susceptible to damage from excessive static voltages. Proper ESD precautions must be taken during handling and storage of this device.

Wolfson tests its package types according to IPC/JEDEC J-STD-020B for Moisture Sensitivity to determine acceptable storage conditions prior to surface mount assembly. These levels are:

MSL1 = unlimited floor life at <30°C / 85% Relative Humidity. Not normally stored in moisture barrier bag.

MSL2 = out of bag storage for 1 year at <30°C / 60% Relative Humidity. Supplied in moisture barrier bag.

MSL3 = out of bag storage for 168 hours at <30°C / 60% Relative Humidity. Supplied in moisture barrier bag.

CONDITION	MIN	MAX
Digital supply voltage	-0.3V	+4.2V
Analogue supply voltage	-0.3V	+7.0V
Voltage range digital inputs	DGND -0.3V	+7.0V
Voltage range analogue inputs	AGND -0.3V	AVDD +0.3V
Master Clock Frequency		37MHz
Operating temperature range, T _A	-25°C	+85°C
Storage temperature prior to soldering	30°C max / 85% RH max	
Storage temperature after soldering	-65°C	+150°C

Notes

1. Analogue and digital grounds must always be within 0.3V of each other.
2. The digital supply voltage must always be less than or equal to the analogue supply voltage.

RECOMMENDED OPERATING CONDITIONS

PARAMETER	SYMBOL	TEST CONDITIONS	MIN	TYP	MAX	UNIT
Digital supply range	DVDD		3.0		3.6	V
Analogue supply range	AVDD		3.0		5.5	V
Ground	DGND,AGND			0		V
Analogue supply current		AVDD = 5.0V, (DVDD at 3.3V)		30		mA
Analogue supply current		AVDD = 3.3V, (DVDD at 3.3V)		19		mA
Supply Current Low Power Mode		AVDD = 5.0V (DVDD at 3.3V)		180		µA
Supply Current Low Power Mode		AVDD = 3.3V (DVDD at 3.3V)		110		µA
Digital supply current		DVDD = 3.3V AVDD = 5.0V or 3.3V		4		mA

ELECTRICAL CHARACTERISTICS

Test Conditions

AVDD = 5.0V, AGND = 0V, DVDD = 3.3V, DGND = 0V, T_A = +25°C, fs = 48kHz, MCLK = 256fs unless otherwise stated.

PARAMETER	SYMBOL	TEST CONDITIONS	MIN	TYP	MAX	UNIT
Digital Logic Levels (TTL Levels)						
Input LOW level	V _{IL}				0.8	V
Input HIGH level	V _{IH}		2.0			V
Output LOW	V _{OL}	I _{OL} = 1mA			0.1 x DVDD	V
Output HIGH	V _{OH}	I _{OH} = 1mA	0.9 x DVDD			V
Pull down resistance (FMT, NOHP)	R _{PD}			100		kΩ
Analogue Reference Levels						
Reference voltage	V _{CAP}		AVDD/2 – 50mV	AVDD/2	AVDD/2 + 50mV	V
Buffered reference voltage	V _{REF}			V _{CAP}		V
Potential divider output impedance	R _{CAP}		40	50	60	kΩ
Input to ADC						
Input Signal Level (0dB)	V _{RIN} / V _{LIN}			1.0		V _{rms}
SNR (Note 1)		A-weighted, 0dB gain @ fs = 48KHz		90		dB
SNR (Note 1)		A-weighted, 0dB gain @ fs = 96KHz		90		dB
SNR (Note 1)		A-weighted, 0dB gain @ fs = 48KHz, AVDD = 3.3V		90		dB
Dynamic Range (Note 2)	DNR	A-weighted, -60dB full scale input	90	97		dB
Total Harmonic Distortion (THD) (Note 3)		-1dB input, 0dB gain		-87		dB
ADC channel separation (Note 5)		1KHz input		95		dB
Power Supply Rejection Ratio	PSRR	1kHz 100mV _{p-p}		50		dB
		20Hz to 20kHz 100mV _{p-p}		45		dB
Input Resistance				20		kΩ
Input Capacitance				10		pF

Notes

- Ratio of output level with 1kHz full scale input, to the output level with the input open circuited, measured 'A' weighted over a 20Hz to 20kHz bandwidth using an Audio analyser.
- All performance measurements done with 20kHz low pass filter, and where noted an A-weight filter. Failure to use such a filter will result in higher THD+N and lower SNR and Dynamic Range readings than are found in the Electrical Characteristics. The low pass filter removes out of band noise; although it is not audible it may affect dynamic specification values.
- V_{REF} and CAP de-coupled with 10uF and 0.1uF capacitors (smaller values may result in reduced performance).
- This data is measured, using an active filter on the device inputs.

TERMINOLOGY

1. Signal-to-noise ratio (dB) - SNR is a measure of the difference in level between the full scale output and the output with no signal applied. (No 'Auto-zero' or Automute function is employed in achieving these results).
2. Dynamic range (dB) - DNR is a measure of the difference between the highest and lowest portions of a signal. Normally a THD+N measurement at 60dB below full scale. The measured signal is then corrected by adding the 60dB to it. (e.g. THD+N @ -60dB= -32dB, DR= 92dB).
3. THD (dB) - THD is a ratio, of the r.m.s. values, of Distortion/Signal.
4. Stop band attenuation (dB) - Is the degree to which the frequency spectrum is attenuated (outside audio band).
5. Channel Separation (dB) - Also known as Cross-Talk. This is a measure of the amount one channel is isolated from the other. Normally measured by sending a full scale signal down one channel and measuring the other.
6. Pass-Band Ripple - Any variation of the frequency response in the pass-band region.

DIGITAL AUDIO INTERFACE TIMING

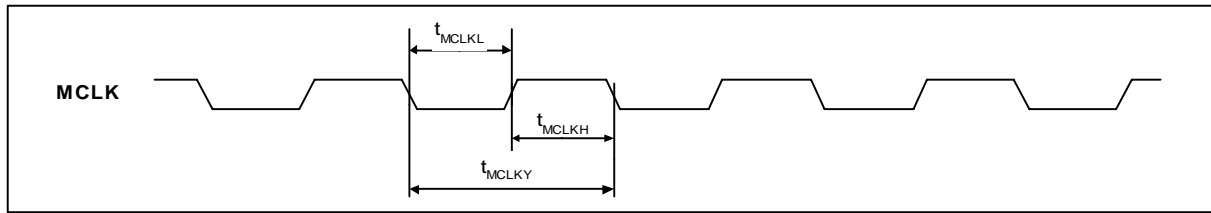

Figure 1 Master Clock Timing Requirements

Test Conditions

AVDD = 5.0V, AGND = 0V, DVDD = 3.3V, DGND = 0V, T_A = +25°C, fs = 48kHz, MCLK = 256fs unless otherwise stated.

PARAMETER	SYMBOL	TEST CONDITIONS	MIN	TYP	MAX	UNIT
System Clock Timing Information						
MCLK System clock pulse width high	T _{MCLKH}		10			ns
MCLK System clock pulse width low	T _{MCLKL}		10			ns
MCLK System clock cycle time	T _{MCLKY}		27			ns

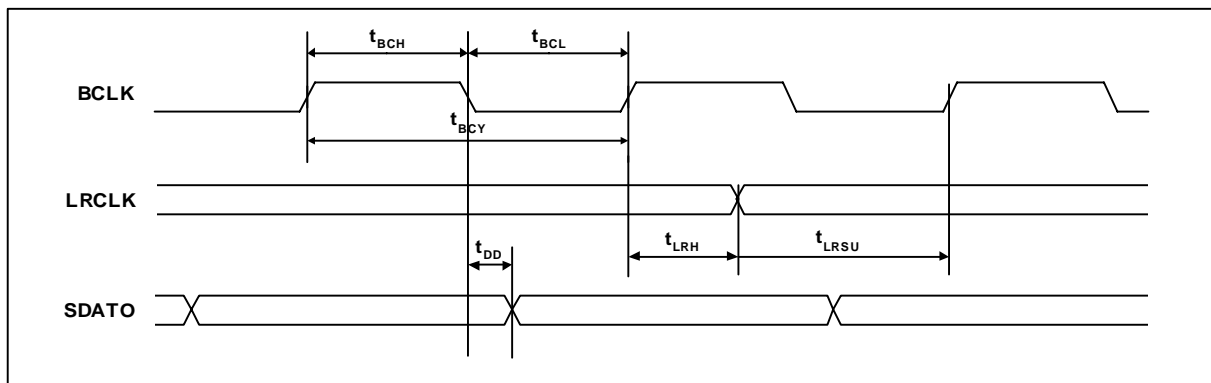

Figure 2 Digital Audio Data Timing

Test Conditions

AVDD = 5.0V, AGND = 0V, DVDD = 3.3V, DGND = 0V, T_A = +25°C, fs = 48kHz, MCLK = 256fs unless otherwise stated.

PARAMETER	SYMBOL	TEST CONDITIONS	MIN	TYP	MAX	UNIT
Audio Data Input Timing Information						
BCLK cycle time	t _{BCY}			80		ns
BCLK pulse width high	t _{BCH}			40		ns
BCLK pulse width low	t _{BCL}			40		ns
LRCLK set-up time to BCLK rising edge	t _{LRSU}			10		ns
LRCLK hold time from BCLK rising edge	t _{LRH}			10		ns
SDATO propagation delay from BCLK falling edge	t _{DD}			10		ns

INTERNAL POWER ON RESET CIRCUIT

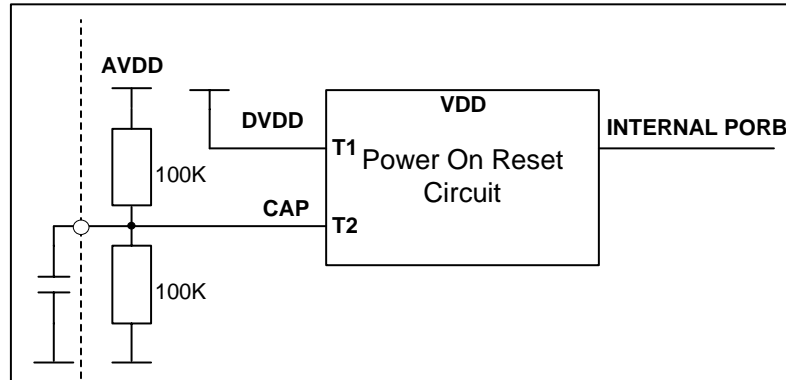

Figure 2 Internal Power On Reset Circuit Schematic

The WM8738 includes an internal Power On Reset Circuit which is used reset the digital logic into a default state after power up.

Figure 2 shows a schematic of the internal POR circuit. The circuit monitors DVDD and CAP and asserts PORB low if DVDD or CAP are below the minimum threshold V_{por_off} .

On power up, the POR circuit requires AVDD to be present to operate. PORB is asserted low until AVDD and DVDD and CAP are established. When AVDD, DVDD, and CAP have been established, PORB is released high, all registers are in their default state and writes to the digital interface may take place.

On power down, PORB is asserted low whenever DVDD or CAP drop below the minimum threshold V_{por_off} .

In most applications the time required for the device to release PORB high will be determined by the charge time of the CAP node.

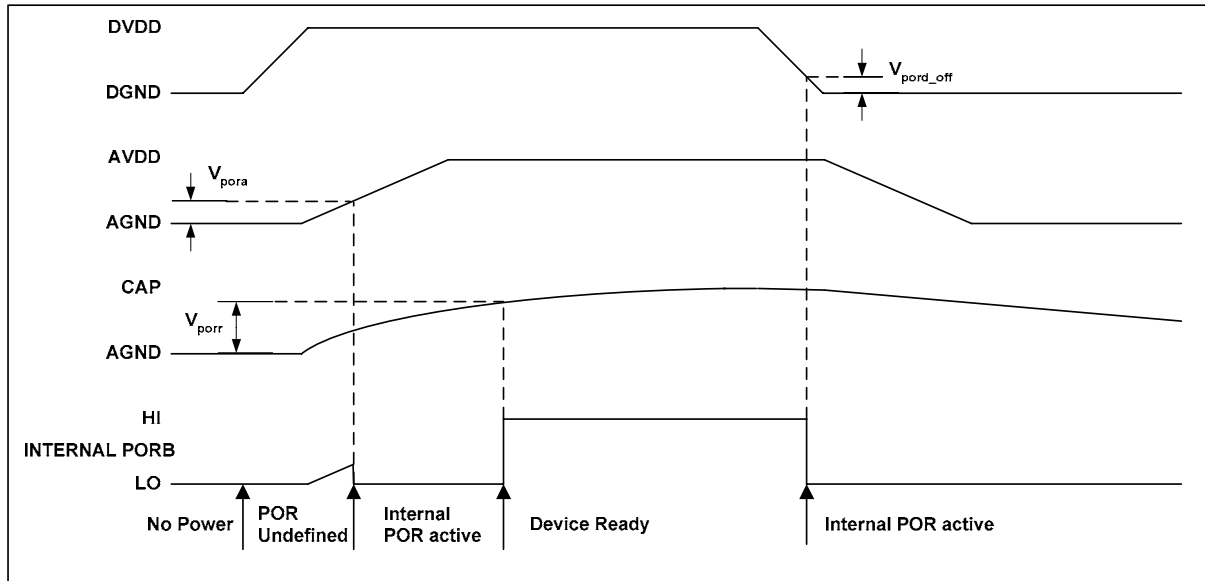

Figure 3 Typical Power up sequence where DVDD is powered before AVDD

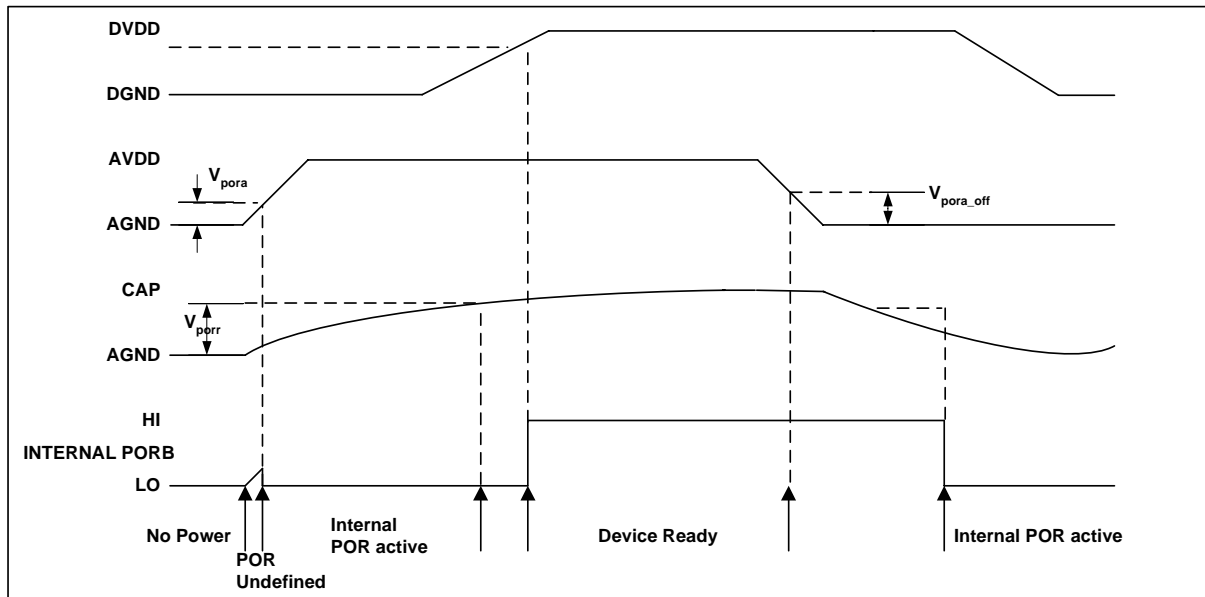

Figure 4 Typical Power up sequence where AVDD is powered before DVDD

Typical POR Operation (typical values, not tested)

SYMBOL	MIN	TYP	MAX	UNIT
V_{pora}	0.5	0.7	1.0	V
V_{porr}	0.5	0.7	1.1	V
V_{pora_off}	1.0	1.4	2.0	V
V_{pord_off}	0.6	0.8	1.0	V

In a real application the designer is unlikely to have control of the relative power up sequence of AVDD and DVDD. Using the POR circuit to monitor CAP ensures a reasonable delay between applying power to the device and Device Ready.

Figure 3 and Figure 4 show typical power up scenarios in a real system. Both AVDD and DVDD must be established and CAP must have reached the threshold V_{porr} before the device is ready and can be written to. Any writes to the device before Device Ready will be ignored.

Figure 3 shows DVDD powering up before AVDD. Figure 4 shows AVDD powering up before DVDD. In both cases, the time from applying power to Device Ready is dominated by the charge time of CAP.

A 10uF cap is recommended for decoupling on CAP. The charge time for CAP will dominate the time required for the device to become ready after power is applied. The time required for VMIDADC to reach the threshold is a function of the CAP resistor string and the decoupling capacitor. The Resistor string has a typical equivalent resistance of 50k Ω (+/-20%). Assuming a 10uF capacitor, the time required for CAP to reach threshold of 1V is approx 110ms.

DEVICE DESCRIPTION

INTRODUCTION

The WM8738 is an ADC designed for audio recording. Its features, performance and low power consumption make it ideal for recordable CD or DVD players, karaoke, MP3 players and mini-disc players.

The on-board stereo analogue to digital converter (ADC) is of a high quality using a multi-bit high-order oversampling architecture delivering optimum performance with low power consumption. The ADC includes a selectable digital high pass filter to remove unwanted DC components from the audio signal. The device supports system clock inputs of 256, 384, 512fs or 768fs (fs is the sampling rate)

The output from the ADC is available on the digital audio interface in either I²S or left justified audio data formats.

The line inputs are biased internally through the operational amplifier to V_{CAP} .

ADC

The WM8738 uses a multi-bit over sampled sigma-delta ADC. A single channel of the ADC is illustrated in Figure 3.

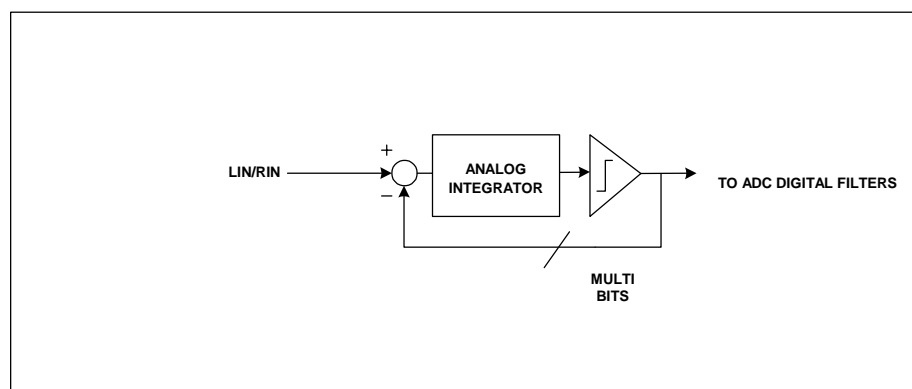

Figure 3 Multi-Bit Oversampling Sigma Delta ADC Schematic

The use of multi-bit feedback and high oversampling rates reduces the effects of jitter and high frequency noise.

The ADC Full Scale input is 1.0V rms at $AVDD = 5.0$ volts. Any voltage greater than full scale will possibly overload the ADC and cause distortion. Note that the full scale input tracks directly with $AVDD$.

The ADC filters perform true 24 bit signal processing to convert the raw multi-bit oversampled data from the ADC to the correct sampling frequency to be output on the digital audio interface.

ADC DIGITAL FILTER

The ADC digital filters contain a digital high pass filter, selectable via pin NOHP.

NOHP = 0 Digital high pass filter enabled

NOHP = 1 Digital high pass filter bypassed

The high-pass filter response detailed in Digital Filter Characteristics. The operation of the high pass filter removes residual DC offsets that are present on the audio signal.

AUDIO DATA SAMPLING RATES

In a typical digital audio system there is only one central clock source producing a reference clock to which all audio data processing is synchronised. This clock is often referred to as the audio system's Master Clock. The external master system clock can be applied directly through the MCLK input pin. In a system where there are a number of possible sources for the reference clock it is recommended that the clock source with the lowest jitter be used to optimise the performance of the ADC.

The master clock for WM8738 supports audio sampling rates from 256fs to 768fs, where fs is the audio sampling frequency LRCLK, typically 32kHz, 44.1kHz, 48kHz, or 96kHz. The master clock is used to operate the digital filters and the noise shaping circuits.

The WM8738 has a master clock detection circuit that automatically determines the relationship between the master clock frequency and the sampling rate (to within +/- 32 system clocks). If there is a greater than 32 clocks error the interface is disabled and maintains the output level at the last sample. The master clock must be synchronised with LRCLK, although the WM8738 is tolerant of phase variations or jitter on this clock. Table 1 shows the typical master clock frequency inputs for the WM8738.

If MCLK is stopped for greater than 10us then the device will enter a low power mode where the current taken from AVDD is greatly reduced. Note that when the device enters this mode the references are powered down.

Table 1 shows the common MCLK frequencies for different sample rates.

SAMPLING RATE (LRCLK)	Master Clock Frequency (MHz)			
	256fs	384fs	512fs	768fs
32kHz	8.192	12.288	16.384	24.576
44.1kHz	11.2896	16.9340	22.5792	33.8688
48kHz	12.288	18.432	24.576	36.864
96kHz	24.576	36.864	Unavailable	Unavailable

Table 1 Master Clock Frequency Selection

DIGITAL AUDIO INTERFACES

The WM8738 has two data output formats, selectable via the FMT pin.

FMT = 0 ADC audio data output is I²S

FMT = 1 ADC audio data output is Left Justified

Both of these modes are MSB first.

The digital audio interface takes the data from the internal ADC digital filter. SDATO is the formatted digital audio data stream output from the ADC digital filters with left and right channels multiplexed together. LRCLK is an alignment clock that controls whether Left or Right channel data is present on the SDATO line. SDATO and LRCLK are synchronous with the BCLK signal with each data bit transition signified by a low to high BCLK transition.

LEFT JUSTIFIED MODE

In left justified mode, the MSB of the ADC data is output on SDATO and changes on the same falling edge of BCLK as LRCLK and may be sampled on the rising edge of BCLK. LRCLK is high during the left samples and low during the right samples.

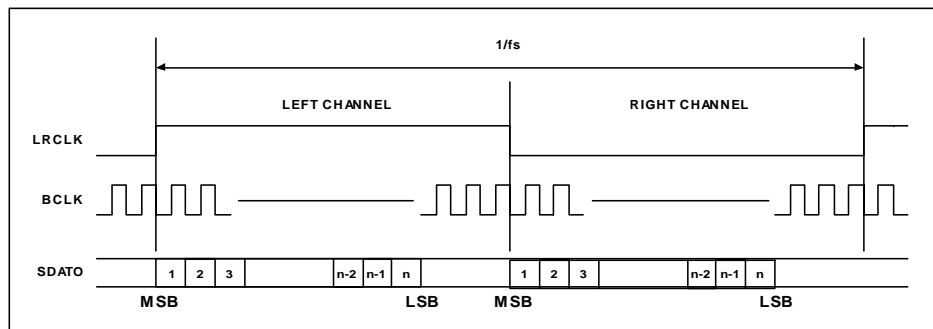

Figure 4 Left Justified Mode Timing Diagram

I²S MODE

In I²S mode, the MSB of the ADC data is output on SDATO and changes on the first falling edge of BCLK following an LRCLK transition and may be sampled on the rising edge of BCLK. LRCLK is low during the left samples and high during the right samples.

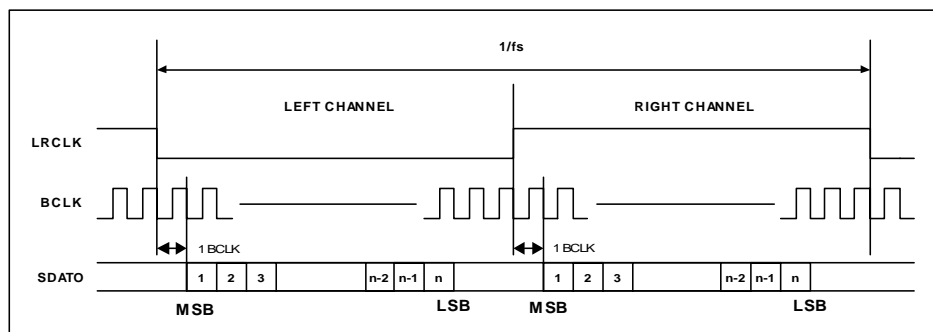

Figure 5 I²S Mode Timing Diagram

DIGITAL FILTER CHARACTERISTICS

PARAMETER	SYMBOL	TEST CONDITIONS	MIN	TYP	MAX	UNIT
Passband		±0.01 dB	0		0.4535fs	dB
Stopband		-6dB		0.5fs		
Passband ripple					±0.01	dB
Stopband			0.5465fs			
Stopband Attenuation		f > 0.5465fs		-65		dB
Group Delay				22		Samples

Table 2 Digital Filter Characteristics

ADC FILTER RESPONSES

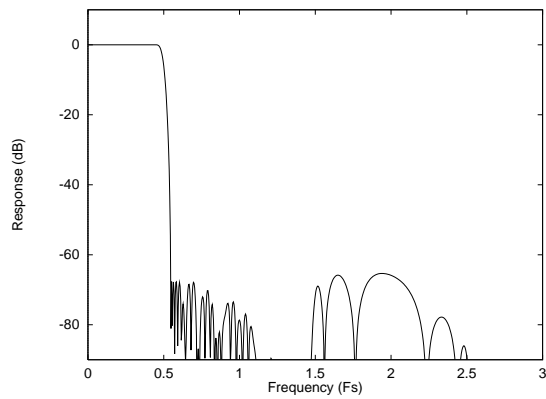

Figure 6 ADC Digital Filter Frequency Response

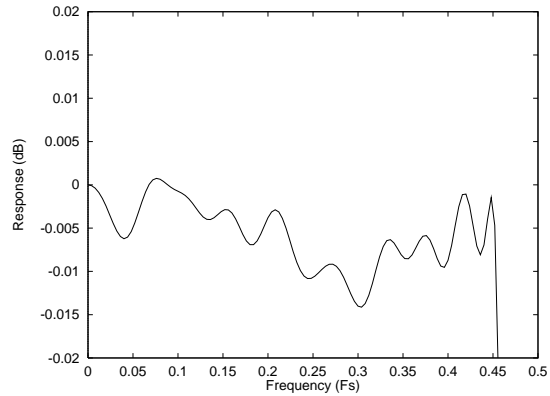

Figure 7 ADC Digital Filter Ripple

ADC HIGH PASS FILTER

The WM8738 has a selectable digital highpass filter to remove DC offsets. The filter response is characterised by the following polynomial.

$$H(z) = \frac{1 - z^{-1}}{1 - 0.9995z^{-1}}$$

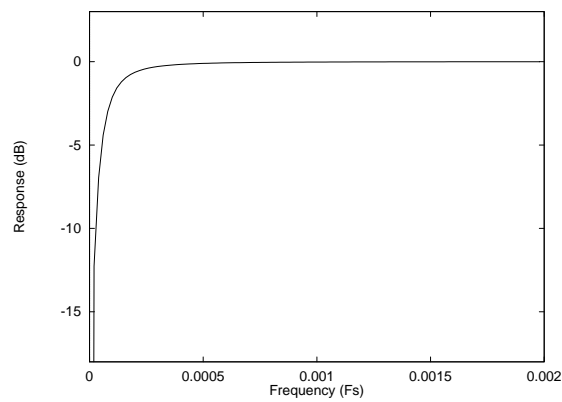

Figure 8 ADC Highpass Filter Response

APPLICATIONS INFORMATION

RECOMMENDED EXTERNAL COMPONENTS

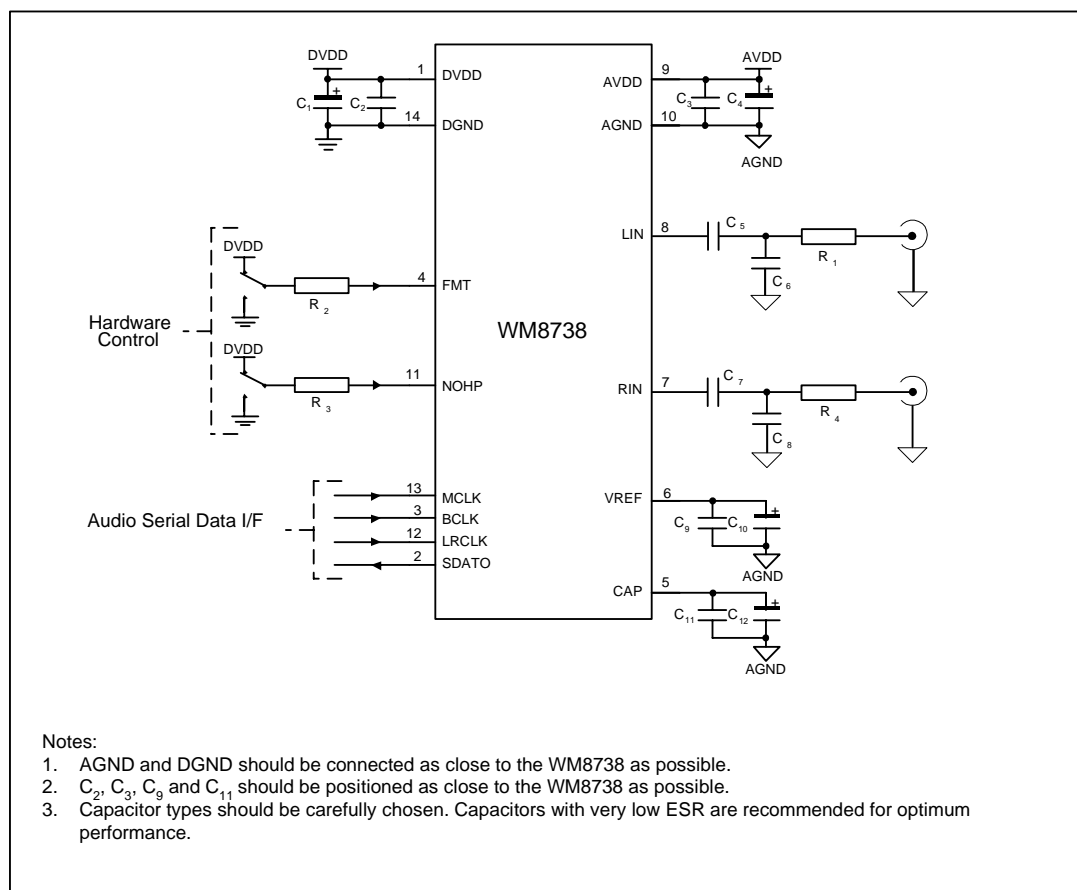

Figure 9 External Components Diagram

RECOMMENDED EXTERNAL COMPONENTS VALUES

COMPONENT REFERENCE	SUGGESTED VALUE	DESCRIPTION
C1 and C4	10 μ F	De-coupling for DVDD and AVDD
C2 and C3	0.1 μ F	De-coupling for DVDD and AVDD
C5 and C7	1 μ F	Analogue input AC coupling caps
C6 and C8	4.7nF	Analogue input filtering (RC) capacitor
R2 and R3	10k Ω	Current limiting resistors
R1 and R4	680 Ω	Analogue input filtering (RC) resistor
C9	0.1 μ F	Reference de-coupling capacitors for VREF pin
C10	10 μ F	
C11	0.1 μ F	Reference de-coupling capacitors for CAP pin
C12	10 μ F	

Table 3 External Components Description

PACKAGE DIMENSIONS

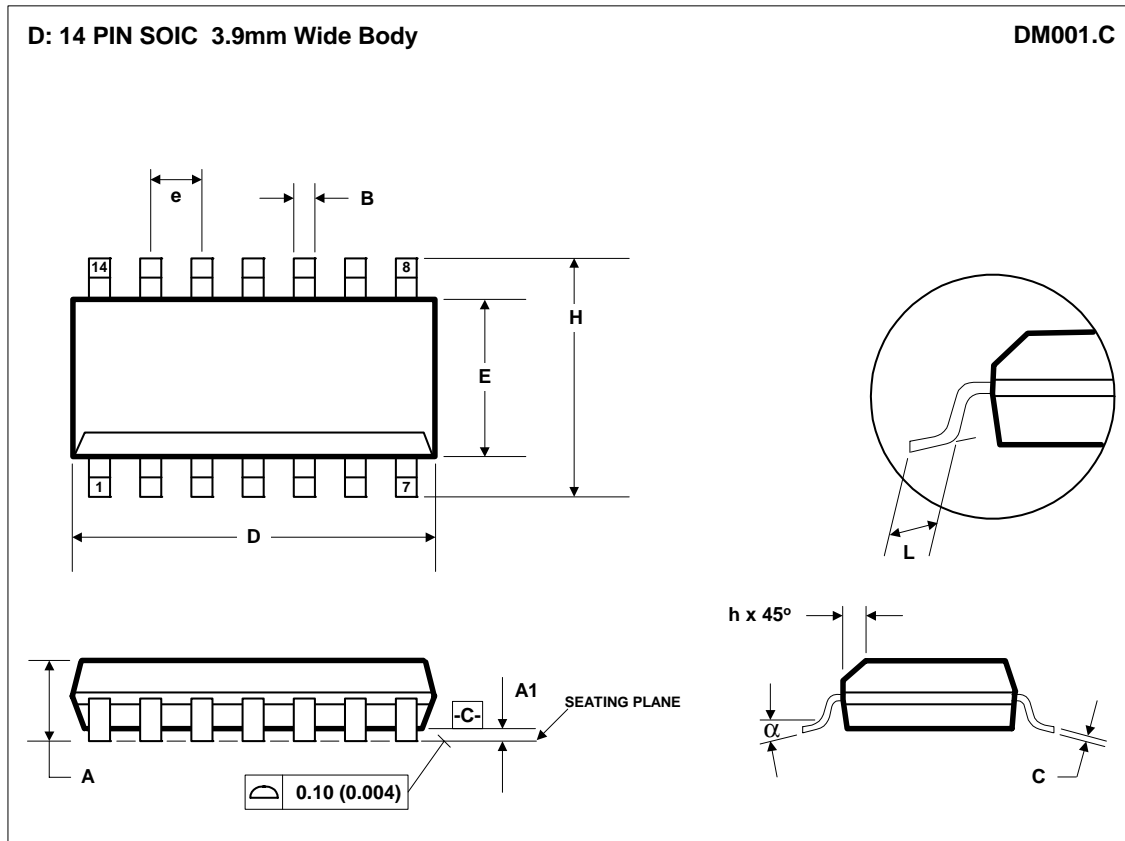

Symbols	Dimensions (mm)		Dimensions (Inches)	
	MIN	MAX	MIN	MAX
A	1.35	1.75	0.0532	0.0688
A1	0.10	0.25	0.0040	0.0098
B	0.33	0.51	0.0130	0.0200
C	0.19	0.25	0.0075	0.0098
D	8.55	8.75	0.3367	0.3444
E	3.80	4.00	0.1497	0.1574
e	1.27 BSC		0.05 BSC	
H	5.80	6.20	0.2284	0.2440
h	0.25	0.50	0.0099	0.0196
L	0.40	1.27	0.0160	0.0500
α	0°	8°	0°	8°
REF:	JEDEC.95, MS-012			

NOTES:
 A. ALL LINEAR DIMENSIONS ARE IN MILLIMETERS (INCHES).
 B. THIS DRAWING IS SUBJECT TO CHANGE WITHOUT NOTICE.
 C. BODY DIMENSIONS DO NOT INCLUDE MOLD FLASH OR PROTRUSION, NOT TO EXCEED 0.25MM (0.010IN).
 D. MEETS JEDEC.95 MS-012, VARIATION = AB. REFER TO THIS SPECIFICATION FOR FURTHER DETAILS.

IMPORTANT NOTICE

Wolfson Microelectronics plc ("Wolfson") products and services are sold subject to Wolfson's terms and conditions of sale, delivery and payment supplied at the time of order acknowledgement.

Wolfson warrants performance of its products to the specifications in effect at the date of shipment. Wolfson reserves the right to make changes to its products and specifications or to discontinue any product or service without notice. Customers should therefore obtain the latest version of relevant information from Wolfson to verify that the information is current.

Testing and other quality control techniques are utilised to the extent Wolfson deems necessary to support its warranty. Specific testing of all parameters of each device is not necessarily performed unless required by law or regulation.

In order to minimise risks associated with customer applications, the customer must use adequate design and operating safeguards to minimise inherent or procedural hazards. Wolfson is not liable for applications assistance or customer product design. The customer is solely responsible for its selection and use of Wolfson products. Wolfson is not liable for such selection or use nor for use of any circuitry other than circuitry entirely embodied in a Wolfson product.

Wolfson's products are not intended for use in life support systems, appliances, nuclear systems or systems where malfunction can reasonably be expected to result in personal injury, death or severe property or environmental damage. Any use of products by the customer for such purposes is at the customer's own risk.

Wolfson does not grant any licence (express or implied) under any patent right, copyright, mask work right or other intellectual property right of Wolfson covering or relating to any combination, machine, or process in which its products or services might be or are used. Any provision or publication of any third party's products or services does not constitute Wolfson's approval, licence, warranty or endorsement thereof. Any third party trade marks contained in this document belong to the respective third party owner.

Reproduction of information from Wolfson datasheets is permissible only if reproduction is without alteration and is accompanied by all associated copyright, proprietary and other notices (including this notice) and conditions. Wolfson is not liable for any unauthorised alteration of such information or for any reliance placed thereon.

Any representations made, warranties given, and/or liabilities accepted by any person which differ from those contained in this datasheet or in Wolfson's standard terms and conditions of sale, delivery and payment are made, given and/or accepted at that person's own risk. Wolfson is not liable for any such representations, warranties or liabilities or for any reliance placed thereon by any person.

ADDRESS:

Wolfson Microelectronics plc
Westfield House
26 Westfield Road
Edinburgh
EH11 2QB
United Kingdom

Tel :: +44 (0)131 272 7000
Fax :: +44 (0)131 272 7001
Email :: sales@wolfsonmicro.com