

Heatsink for PAROLI® Backplane Module

V23814-Z6-Z1

1 General Scope

This data sheet describes the detachable heatsink for PAROLI® Backplane module V23814-x1306-M133¹⁾ (transmitter) resp. V23815-x1306-M133¹⁾ (receiver).

2 Technical Data

See Figure 1.

Dimensions	45 x 24 x 8.75±0.2 mm (L x W x H)
Material	Al Mg 4.5 Mn, black anodized
Coefficient of thermal conduction	110...140 W m ⁻¹ K ⁻¹
No. of fins	14 (1.4 mm width)

3 Application and Assembly

Application is the use of the heatsink to attach onto the module baseplate.

For optimized heat transfer between module and heatsink Infineon recommends to use a heat dissipation foil between both parts (e.g. Panasonic PGS 0.1 mm thickness). Dimensions see **Figure 2**.

The fixing is done by two screws.

Recommendation for screw dimensions: ISO 7045 - M1.6 x 6 - A2 50 - H.

The screws have to be fixed with 10 Ncm.

¹⁾ x = K for 1.25 Gbit/s
 x = U for 1.6 Gbit/s
 x = Q for 2.7 Gbit/s

PAROLI® is a registered trademark of Infineon Technologies

4 Package Outlines

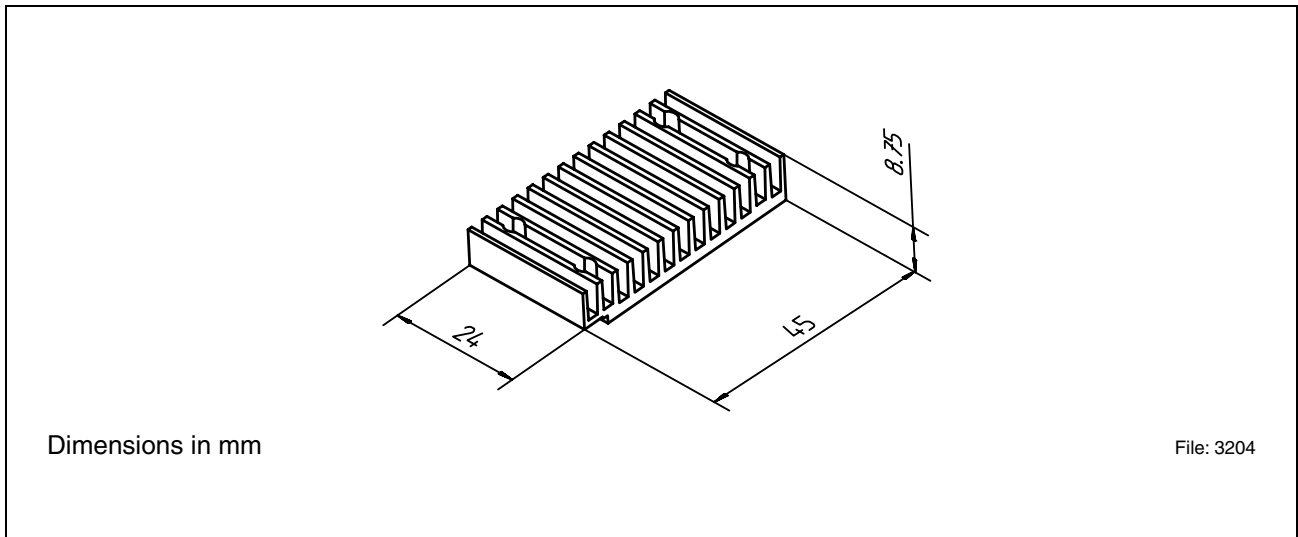

Figure 1 Heatsink PAROLI Backplane Module

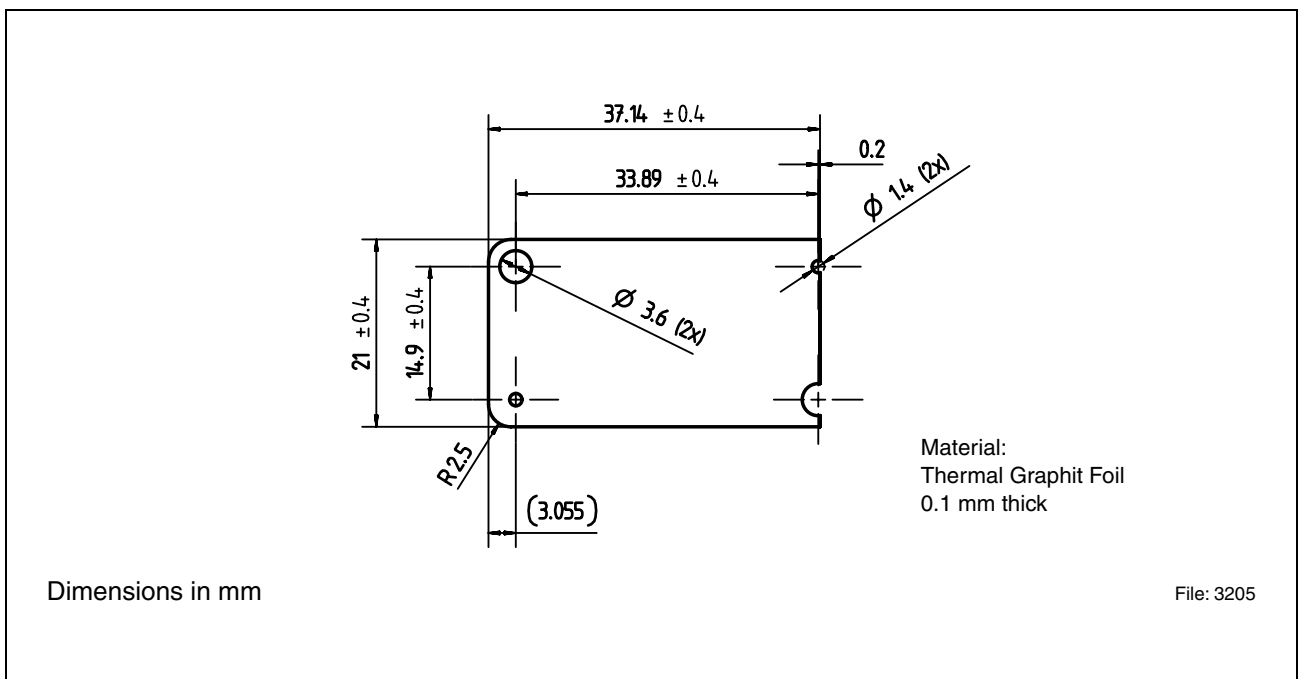

Figure 2 Heat Dissipation Foil

Previous Version:

Page	Subjects (major changes since last revision)

For questions on technology, delivery and prices please contact the Infineon Technologies Offices in Germany or the Infineon Technologies Companies and Representatives worldwide: see our webpage at <http://www.infineon.com>.

Edition 2003-07-25

**Published by Infineon Technologies AG,
St.-Martin-Strasse 53,
D-81541 München, Germany**

**© Infineon Technologies AG 2003.
All Rights Reserved.**

Attention please!

The information herein is given to describe certain components and shall not be considered as warranted characteristics.

Terms of delivery and rights to technical change reserved.

We hereby disclaim any and all warranties, including but not limited to warranties of non-infringement, regarding circuits, descriptions and charts stated herein.

Infineon Technologies is an approved CECC manufacturer.

Information

For further information on technology, delivery terms and conditions and prices please contact your nearest Infineon Technologies Office in Germany or our Infineon Technologies Representatives worldwide.

Warnings

Due to technical requirements components may contain dangerous substances. For information on the types in question please contact your nearest Infineon Technologies Office.

Infineon Technologies Components may only be used in life-support devices or systems with the express written approval of Infineon Technologies, if a failure of such components can reasonably be expected to cause the failure of that life-support device or system, or to affect the safety or effectiveness of that device or system. Life-support devices or systems are intended to be implanted in the human body, or to support and/or maintain and sustain and/or protect human life. If they fail, it is reasonable to assume that the health of the user or other persons may be endangered.