



L5200

CMOS IC

LOW NOISE, REGULATED CHARGE PUMP DC/DC CONVERTERS

DESCRIPTION

The UTC **L5200-xx** series are low noise, constant frequency charge pump DC/DC converters and designed to increase efficiency in white LED application. The operating voltage range is 2.7V ~ V_{OUT} input with up to 100mA of output current. Low external parts counts (one flying capacitor and two small bypass capacitors at V_{IN} and V_{OUT}) make the UTC **L5200-xx** series ideally suited for small, battery-powered applications.

A charge-pump architecture maintains constant switching frequency to zero load and reduces both output and input ripple. The UTC **L5200-xx** series have thermal shutdown capability to escape the device damaged from a continuous short-circuit. With built-in soft-start circuitry to prevents excessive current flow at V_{IN} during start-up. High switching frequency enables the use of small ceramic capacitors. A low-current shutdown feature disconnects the load from V_{IN} and reduces quiescent current to $<1\mu A$.

The **L5200-ADJ** is available in MSOP-8 package and **L5200-fixed** in SOT-26 and TSOT-26 package.

FEATURES

- * Low Noise Constant Frequency Operation
- * Output Current: 100mA
- * 2MHz Switching Frequency
- * 4.5V/5.0V Fixed Output Voltage
- * V_{IN} Range: 2.7V ~ V_{OUT}
- * Automatic Soft-Start.
- * No Inductors
- * Less than $1\mu A$ of Shutdown Current

ORDERING INFORMATION

Ordering Number		Package	Packing
Normal	Lead Free Plating		
L5200-AD-SM1-R	L5200L-AD-SM1-R	MSOP-8	Tape Reel
L5200-AD-SM1-T	L5200L-AD-SM1-T	MSOP-8	Tube
L5200-xx-AG6-R	L5200L-xx-AG6-R	SOT-26	Tape Reel
L5200-xx-AH6-R	L5200L-xx-AH6-R	TSOT-26	Tape Reel

Note: xx :output voltage

<p>L5200L-AD-SM1-R</p>	<p>(1)Packing Type (2)Package Type (3)Output Voltage (4)Lead Plating</p>	<p>(1) R: Tape Reel T: Tube (2) SM1: MSOP-8, AG6: SOT-26, AH6: TSOT-26 (3) AD: ADJ, xx: 45:4.5V, 50:5.0V (4) L: Lead Free Plating Blank: Pb/Sn</p>
------------------------	--	--

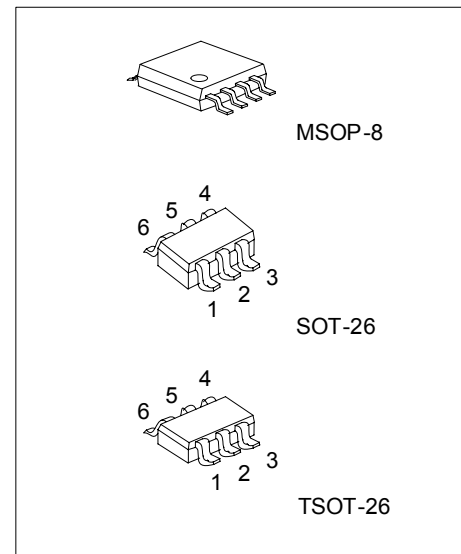

*Pb-free plating product number: L5200L

■ MARKING (For SOT-26/TSOT-26)

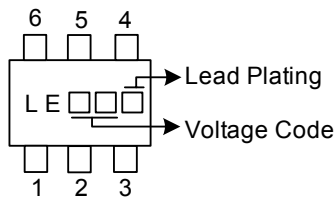

■ PIN CONFIGURATIONS

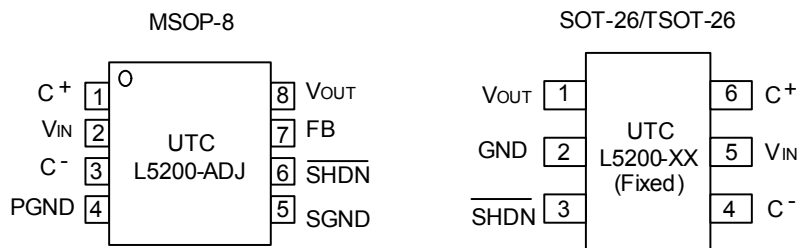

■ PIN DESCRIPTION

PIN NO.		PIN NAME	FUNCTION
L5200-ADJ MSOP-8	L5200-xx SOT-26/TSOT-26		
1	6	C+	Flying Capacitor Positive Terminal
2	5	V _{IN}	Input Supply Voltage, should be bypassed with a 1μF~4.7μF low ESR ceramic capacitor.
3	4	C ⁻	Flying Capacitor Negative Terminal
4, 5	2	GND	Ground terminal, should be tied to a ground plane for best performance
6	3	$\overline{\text{SHDN}}$	Shutdown Mode, Active-Low Input. A low on $\overline{\text{SHDN}}$ disables the L5200 series. $\overline{\text{SHDN}}$ must not be allowed to float.
7	X	FB	Feedback Input Pin for Adjustable output. An output divider should be connected from V _{OUT} to FB to program the output voltage.
8	1	V _{OUT}	Regulated Output Voltage, should be bypassed with a 1μF~4.7μF low ESR ceramic capacitor as close as possible to the pin for best performance

X : The pin is Inexistent for SOT-26 and TSOT-26 package.

■ BLOCK DIAGRAM

UTC L5200 Adjustable version (MSOP-8)

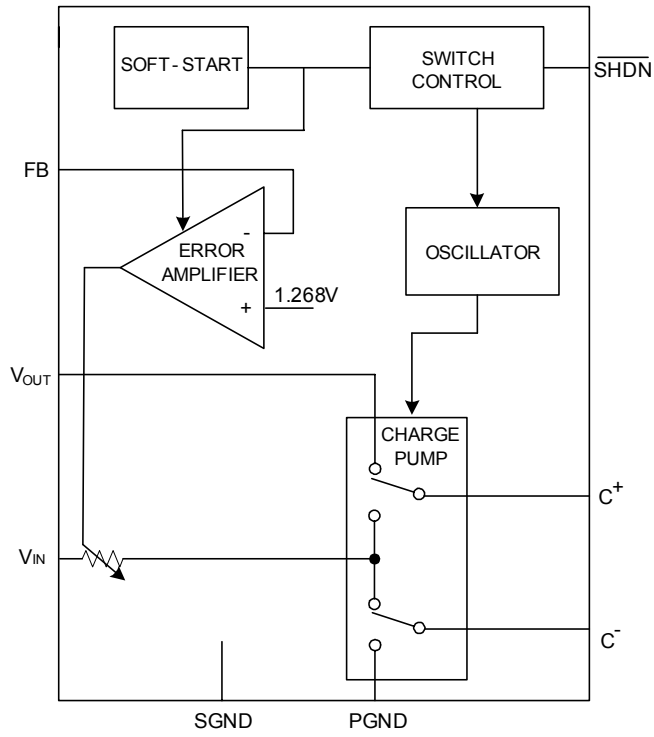

UTC L5200 fixed version (SOT-26/TSOT-26)

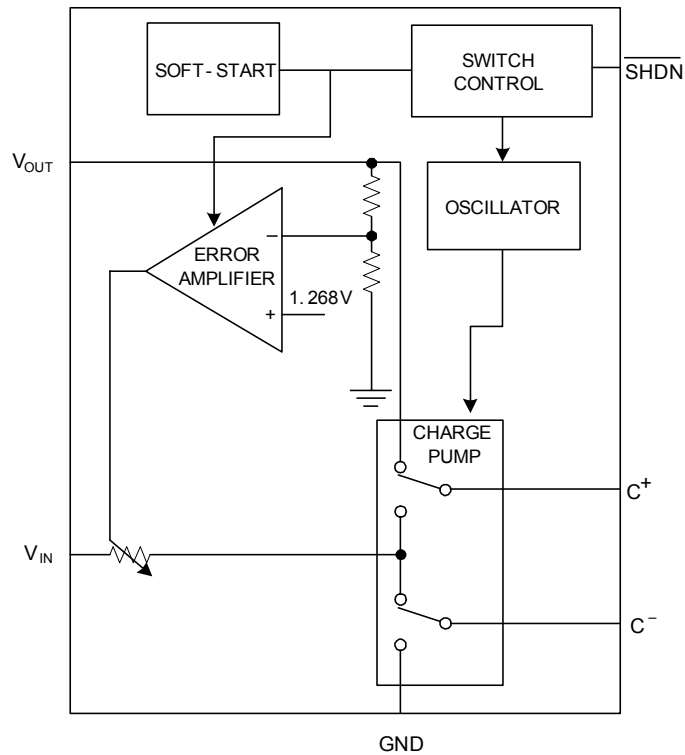

■ ABSOLUTE MAXIMUM RATINGS

PARAMETER	SYMBOL	RATINGS	UNIT
Input Voltage(to GND)	V_{IN}	-0.3 ~ 6	V
Charge Pump Voltage(to GND)	V_{OUT}	-0.3 ~ 5.5	V
Shutdown Voltage(to GND)	V_{SHDN}	-0.3 ~ ($V_{IN}+0.3$)	V
Maximum DC Output Current (Note 1)	I_{OUT}	150	mA
V_{OUT} Short-Circuit Duration		Indefinite	
Operating Temperature	T_{OPR}	-20 ~ +85	
Storage Temperature	T_{STG}	-40 ~ +150	

Note 1: Based on long-term current density limitations.

2: Stressed above Absolute Maximum Ratings may impair life or cause permanent damage to the device.

3. The device is guaranteed to meet performance specification within 0 ~+70 operating temperature range and assured by design from -20 ~+85 , characteristic and correlation with static process control.

■ ELECTRICAL CHARACTERISTICS

($T_a = 25$, $V_{IN} = 3.6V$, $C_{FLY} = 1\mu F$, $C_{IN} = 1\mu F$, $C_{OUT} = 1\mu F$, unless otherwise specified.)

PARAMETER	SYMBOL	TEST CONDITIONS	MIN	TYP	MAX	UNIT	
Input Supply Voltage Range	V_{IN}		*	2.7		V_{OUT} V	
Output Voltage	L5200-4.5V	V_{OUT} $I_{OUT} \leq 100mA$		4.41	4.5	4.59	V
	L5200-5.0V		*	4.9	5	5.1	V
Shutdown Input Threshold	V_{IH}		*	1.3		V	
	V_{IL}		*		0.4	V	
Feedback Voltage (For L5200-ADJ)	V_{FB}		*	1.217	1.268	1.319	V
Output Ripple Voltage(For L5200-fixed)	V_R	$V_{IN} = 3V$, $I_{OUT} = 100mA$		30		mV _{P-P}	
Operating Supply Current	I_{CC}	$I_{OUT} = 0mA$, $\overline{SHDN} = V_{IN}$	*	3.5	8	mA	
Shutdown Current	I_{SHDN}	$\overline{SHDN} = 0V$, $V_{OUT} = 0V$	*		1	μA	
Shutdown Input Current	I_{IH}	$\overline{SHDN} = V_{IN}$	*	-1	1	μA	
	I_{IL}	$\overline{SHDN} = 0V$	*	-1	1	μA	
Feedback Input Current (For L5200-ADJ)	I_{FB}	$V_{FB} = 1.4V$	*	-50	50	nA	
Open-Loop Output Resistance	R_{OL}	$V_{IN} = 3V$, $I_{OUT} = 100mA$ $V_{FB} = 0V$ ($R_{OL} \equiv (2V_{IN} - V_{OUT})/I_{OUT}$)		9.2		Ω	
Switching Frequency	F_{OSC}			1	2	MHz	
Efficiency (For UTC L5200-fixed)	η	$V_{IN} = 3V$, $I_{OUT} = 50mA$		80		%	
Soft Start Time	t_{ON}	$V_{IN} = 3V$, $I_{OUT} = 0mA$ 10%~90%		0.8		ms	

Note: * stand for specifications which apply over the designed operating temperature range.

TYPICAL APPLICATION CIRCUIT

Regulated 5V Output from a 2.7V ~ V_{OUT} Input

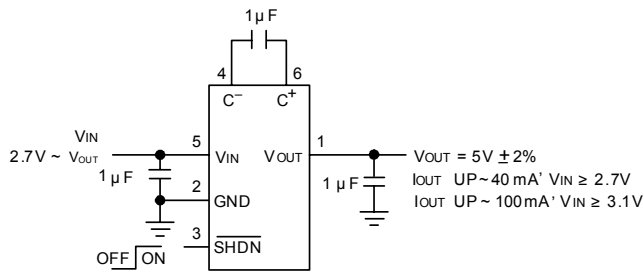

UTC L5200-5.0V

Output Ripple Voltage vs Load Current

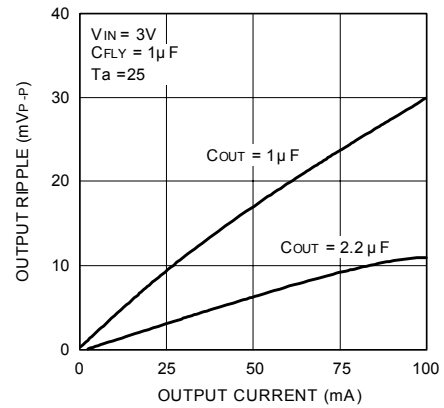

White or Blue LED Driver with LED Current Control (UTC L5200-ADJ)

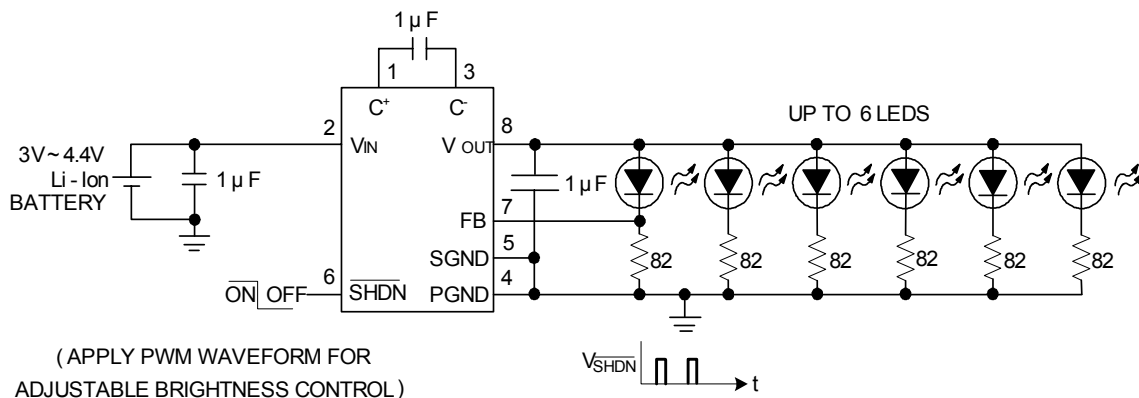

USB Port to Regulated 5V Power Supply (UTC L5200-5.0V)

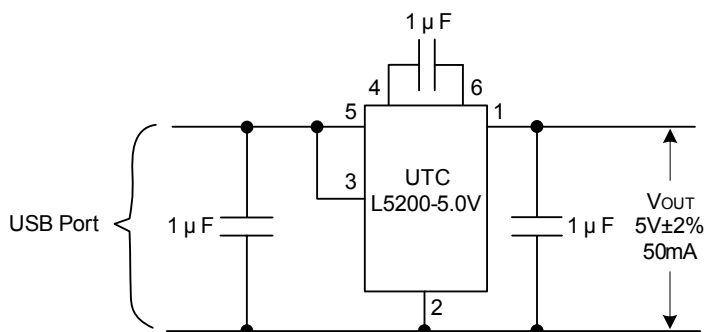

■ TYPICAL CHARACTERISTICS (L5200-5.0V)

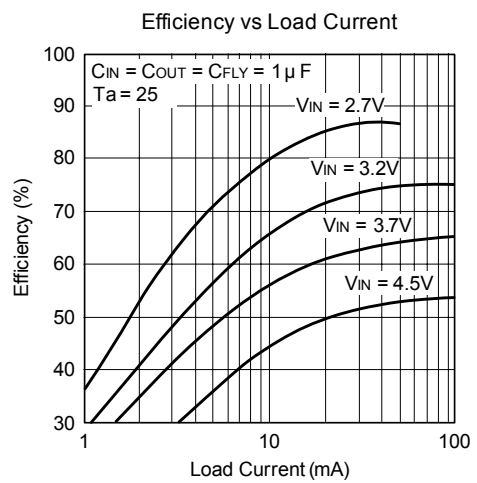
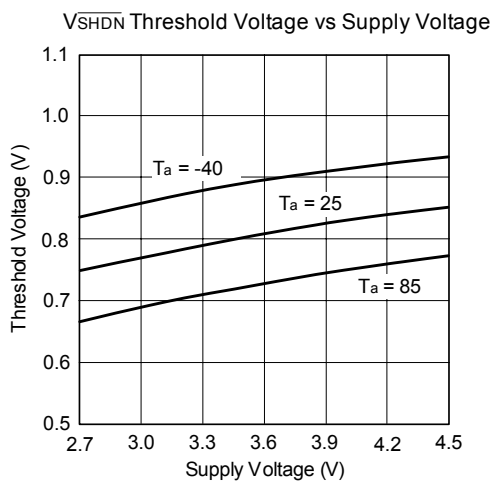
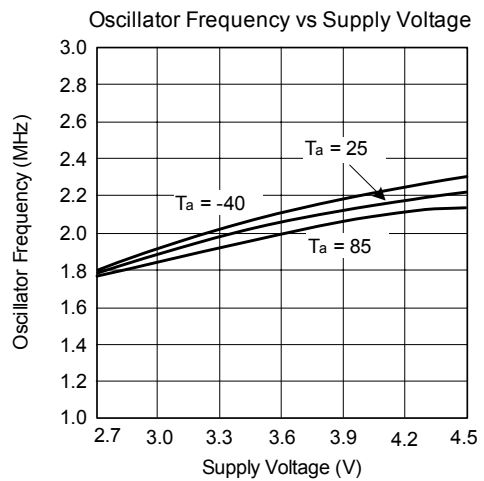
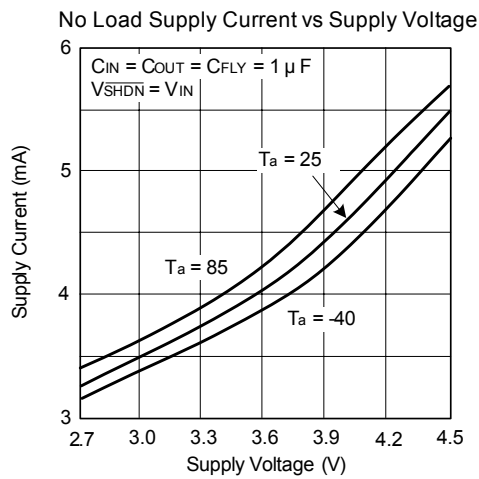
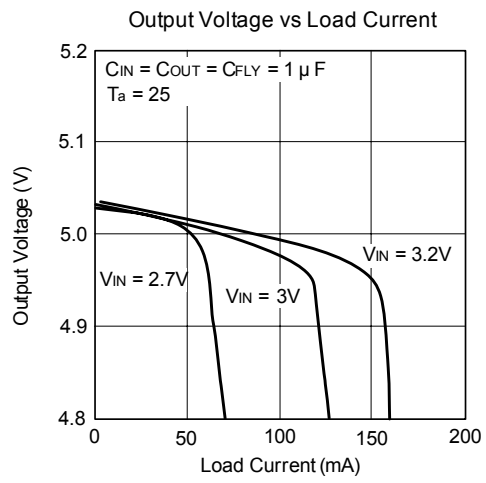
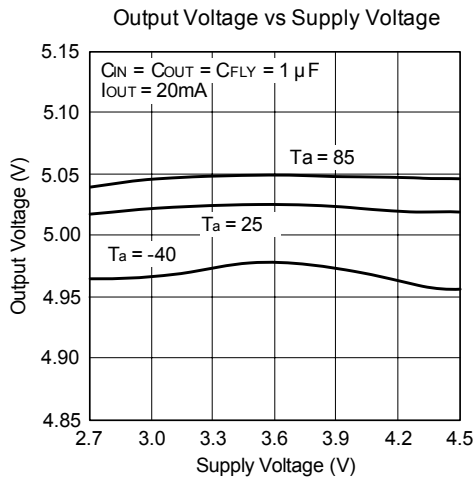

■ TYPICAL CHARACTERISTICS (L5200-5.0V) (cont.)

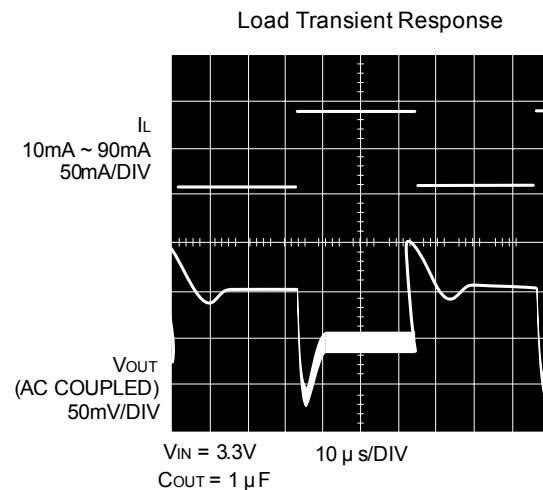
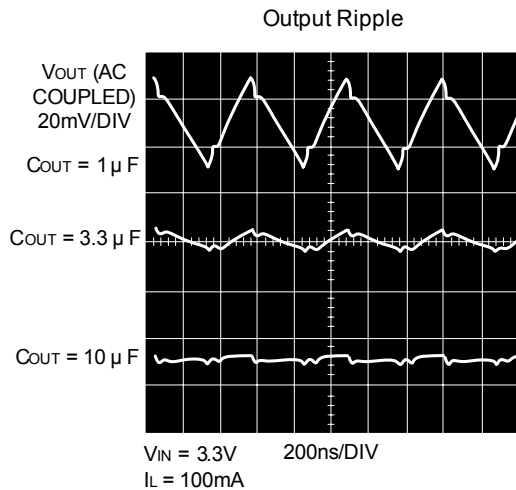
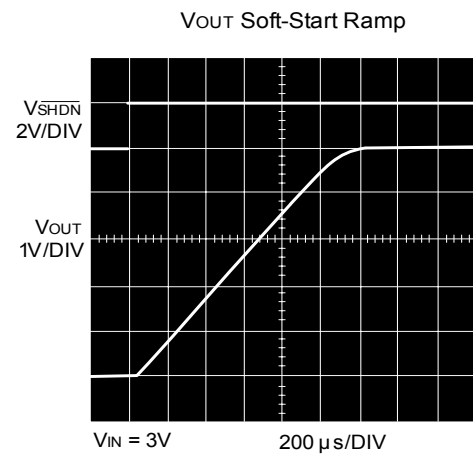
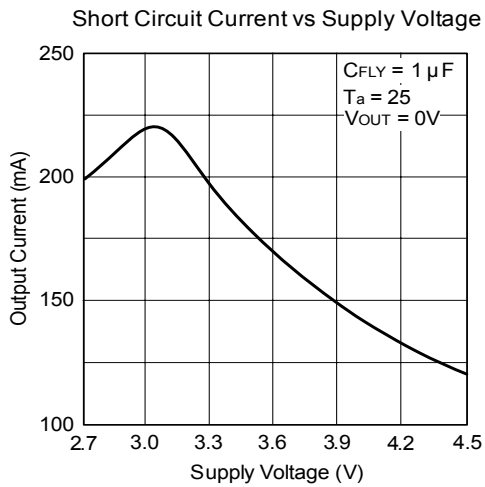

UTC assumes no responsibility for equipment failures that result from using products at values that exceed, even momentarily, rated values (such as maximum ratings, operating condition ranges, or other parameters) listed in products specifications of any and all UTC products described or contained herein. UTC products are not designed for use in life support appliances, devices or systems where malfunction of these products can be reasonably expected to result in personal injury. Reproduction in whole or in part is prohibited without the prior written consent of the copyright owner. The information presented in this document does not form part of any quotation or contract, is believed to be accurate and reliable and may be changed without notice.