

## SimtekSoftStore 2K x 8 nvSRAM

### Features

- High-performance CMOS nonvolatile static RAM 2048 x 8 bits
- 25, 35 and 45 ns Access Times
- 12, 20 and 25 ns Output Enable Access Times
- Software STORE Initiation (STORE Cycle Time < 10 ms)
- Automatic STORE Timing
- 10<sup>6</sup> STORE cycles to EEPROM
- 100 years data retention in EEPROM
- Automatic RECALL on Power Up
- Software RECALL Initiation (RECALL Cycle Time < 20 μs)
- Unlimited RECALL cycles from EEPROM
- Unlimited Read and Write to SRAM
- Single 5 V ± 10 % Operation
- Operating temperature ranges:  
0 to 70 °C  
-40 to 85 °C
- QS 9000 Quality Standard
- ESD protection > 2000 V (MIL STD 883C M3015.7-HBM)
- RoHS compliance and Pb- free
- Packages: PDIP28 (600 mil)  
SOP24 (300 mil)

### Description

The U631H16 has two separate modes of operation: SRAM mode and nonvolatile mode. In SRAM mode, the memory operates as an ordinary static RAM. In nonvolatile operation, data is transferred in parallel from SRAM to EEPROM or from EEPROM to SRAM. In this mode SRAM functions are disabled.

The U631H16 is a fast static RAM (25, 35, 45 ns), with a nonvolatile electrically erasable PROM (EEPROM) element incorporated in each static memory cell. The SRAM can be read and written an unlimited number of times, while independent nonvolatile data resides in EEPROM.

Data transfers from the SRAM to the EEPROM (the STORE operation), or from the EEPROM to the SRAM (the RECALL ) operation) are initiated through software sequences.

The U631H16 combines the high performance and ease of use of a fast SRAM with nonvolatile data

integrity.

Once a STORE cycle is initiated, further input or output are disabled until the cycle is completed.

Because a sequence of addresses is used for STORE initiation, it is important that no other read or write accesses intervene in the sequence or the sequence will be aborted.

Internally, RECALL is a two step procedure. First, the SRAM data is cleared and second, the nonvolatile information is transferred into the SRAM cells.

The RECALL operation in no way alters the data in the EEPROM cells. The nonvolatile data can be recalled an unlimited number of times.

### Pin Configuration

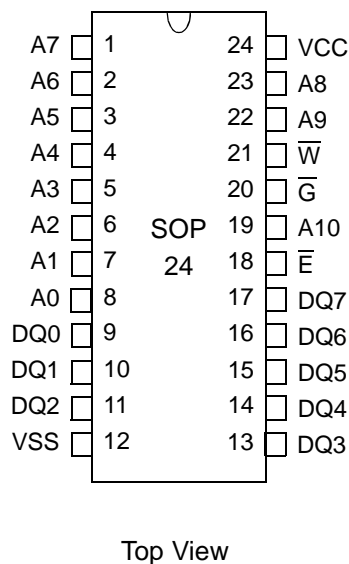
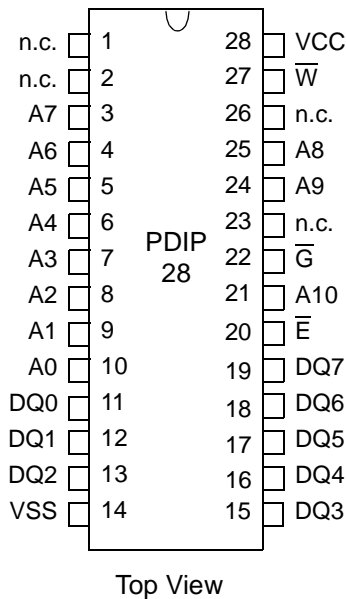

### Pin Description

Signal Name	Signal Description
A0 - A10	Address Inputs
DQ0 - DQ7	Data In/Out
$\bar{E}$	Chip Enable
$\bar{G}$	Output Enable
$\bar{W}$	Write Enable
VCC	Power Supply Voltage
VSS	Ground

# U631H16

## Block Diagram

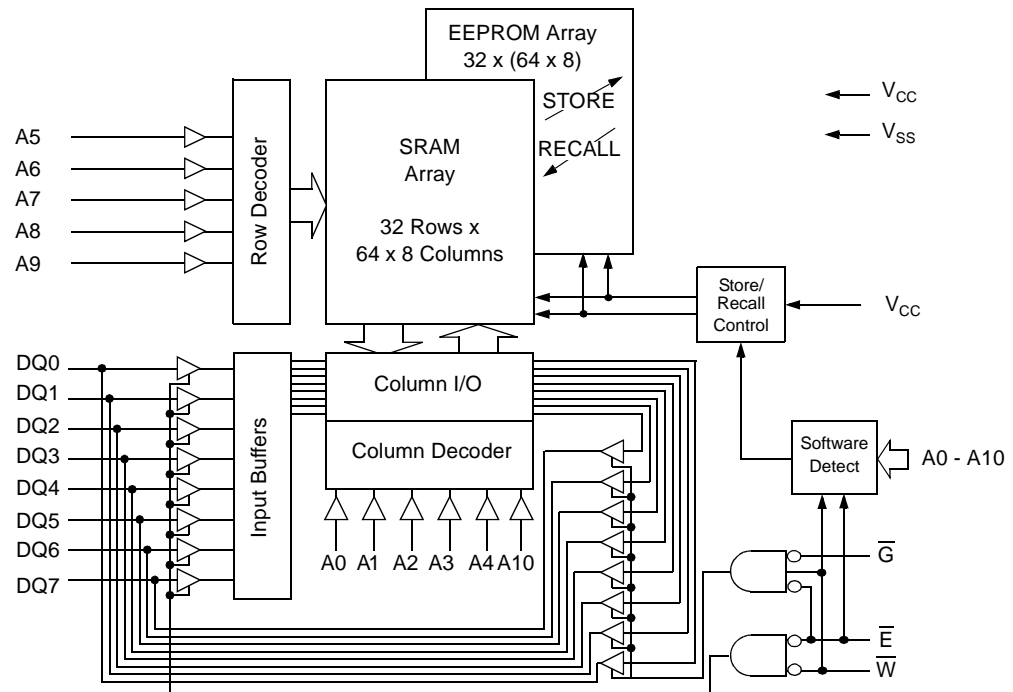

## Truth Table for SRAM Operations

Operating Mode	$\bar{E}$	$\bar{W}$	$\bar{G}$	DQ0 - DQ7
Standby/not selected	H	*	*	High-Z
Internal Read	L	H	H	High-Z
Read	L	H	L	Data Outputs Low-Z
Write	L	L	*	Data Inputs High-Z

\* H or L

## Characteristics

All voltages are referenced to  $V_{SS} = 0$  V (ground).

All characteristics are valid in the power supply voltage range and in the operating temperature range specified.

Dynamic measurements are based on a rise and fall time of  $\leq 5$  ns, measured between 10 % and 90 % of  $V_I$ , as well as input levels of  $V_{IL} = 0$  V and  $V_{IH} = 3$  V. The timing reference level of all input and output signals is 1.5 V, with the exception of the  $t_{dis}$ -times and  $t_{en}$ -times, in which cases transition is measured  $\pm 200$  mV from steady-state voltage.

Absolute Maximum Ratings <sup>a</sup>	Symbol	Min.	Max.	Unit
Power Supply Voltage	$V_{CC}$	-0.5	7	V
Input Voltage	$V_I$	-0.3	$V_{CC}+0.5$	V
Output Voltage	$V_O$	-0.3	$V_{CC}+0.5$	V
Power Dissipation	$P_D$		1	W
Operating Temperature	C-Type	0	70	°C
	K-Type	-40	85	°C
Storage Temperature	$T_{stg}$	-65	150	°C

a: Stresses greater than those listed under „Absolute Maximum Ratings“ may cause permanent damage to the device. This is a stress rating only, and functional operation of the device at condition above those indicated in the operational sections of this specification is not implied. Exposure to absolute maximum rating conditions for extended periods may affect reliability.

Recommended Operation Conditions	Symbol	Conditions	Min.	Max.	Unit
Power Supply Voltage	$V_{CC}$		4.5	5.5	V
Input Low Voltage	$V_{IL}$	-2 V at Pulse Width 10 ns permitted	-0.3	0.8	V
Input High Voltage	$V_{IH}$		2.2	$V_{CC}+0.3$	V

DC Characteristics	Symbol	Conditions	C-Type		K-Type		Unit
			Min.	Max.	Min.	Max.	
Operating Supply Current <sup>b</sup>	$I_{CC1}$	$V_{CC} = 5.5\text{ V}$ $V_{IL} = 0.8\text{ V}$ $V_{IH} = 2.2\text{ V}$  $t_c = 25\text{ ns}$ $t_c = 35\text{ ns}$ $t_c = 45\text{ ns}$		90 80 75		95 85 80	mA mA mA
Average Supply Current during STORE <sup>c</sup>	$I_{CC2}$	$V_{CC} = 5.5\text{ V}$ $\overline{E} \geq V_{CC}-0.2\text{ V}$ $\overline{W} \geq V_{CC}-0.2\text{ V}$ $V_{IL} \leq 0.2\text{ V}$ $V_{IH} \geq V_{CC}-0.2\text{ V}$		6		7	mA
Standby Supply Current <sup>d</sup> (Cycling TTL Input Levels)	$I_{CC(SB)1}$	$V_{CC} = 5.5\text{ V}$ $\overline{E} \geq V_{IH}$  $t_c = 25\text{ ns}$ $t_c = 35\text{ ns}$ $t_c = 45\text{ ns}$		30 23 20		34 27 23	mA mA mA
Average Supply Current at $t_{cR} = 200\text{ ns}^b$ (Cycling CMOS Input Levels)	$I_{CC3}$	$V_{CC} = 5.5\text{ V}$ $\overline{W} \geq V_{CC}-0.2\text{ V}$ $V_{IL} \leq 0.2\text{ V}$ $V_{IH} \geq V_{CC}-0.2\text{ V}$		15		15	mA
Standby Supply Current <sup>d</sup> (Stable CMOS Input Levels)	$I_{CC(SB)}$	$V_{CC} = 5.5\text{ V}$ $\overline{E} \geq V_{CC}-0.2\text{ V}$ $V_{IL} \leq 0.2\text{ V}$ $V_{IH} \geq V_{CC}-0.2\text{ V}$		1		1	mA

b:  $I_{CC1}$  and  $I_{CC3}$  are dependent on output loading and cycle rate. The specified values are obtained with outputs unloaded. The current  $I_{CC1}$  is measured for WRITE/READ - ratio of 1/2.

c:  $I_{CC2}$  is the average current required for the duration of the STORE cycle (STORE Cycle Time).

d: Bringing  $\overline{E} \geq V_{IH}$  will not produce standby current levels until any nonvolatile cycle in progress has timed out. See MODE SELECTION table. The current  $I_{CC(SB)1}$  is measured for WRITE/READ - ratio of 1/2.

DC Characteristics	Symbol	Conditions	C-Type		K-Type		Unit
			Min.	Max.	Min.	Max.	
Output High Voltage Output Low Voltage	$V_{OH}$ $V_{OL}$	$V_{CC} = 4.5\text{ V}$ $I_{OH} = -4\text{ mA}$ $I_{OL} = 8\text{ mA}$	2.4	0.4	2.4	0.4	V V
Output High Current Output Low Current	$I_{OH}$ $I_{OL}$	$V_{CC} = 4.5\text{ V}$ $V_{OH} = 2.4\text{ V}$ $V_{OL} = 0.4\text{ V}$	8	-4	8	-4	mA mA
Input Leakage Current  High Low	$I_{IH}$ $I_{IL}$	$V_{CC} = 5.5\text{ V}$ $V_{IH} = 5.5\text{ V}$ $V_{IL} = 0\text{ V}$	-1	1	-1	1	$\mu\text{A}$ $\mu\text{A}$
Output Leakage Current  High at Three-State- Output Low at Three-State- Output	$I_{OHZ}$ $I_{OLZ}$	$V_{CC} = 5.5\text{ V}$ $V_{OH} = 5.5\text{ V}$ $V_{OL} = 0\text{ V}$	-1	1	-1	1	$\mu\text{A}$ $\mu\text{A}$

## SRAM Memory Operations

No.	Switching Characteristics Read Cycle	Symbol		25		35		45		Unit
		Alt.	IEC	Min.	Max.	Min.	Max.	Min.	Max.	
1	Read Cycle Time <sup>f</sup>	$t_{AVAV}$	$t_{cR}$	25		35		45		ns
2	Address Access Time to Data Valid <sup>g</sup>	$t_{AVQV}$	$t_{a(A)}$		25		35		45	ns
3	Chip Enable Access Time to Data Valid	$t_{ELQV}$	$t_{a(E)}$		25		35		45	ns
4	Output Enable Access Time to Data Valid	$t_{GLQV}$	$t_{a(G)}$		12		20		25	ns
5	$\overline{E}$ HIGH to Output in High-Z <sup>h</sup>	$t_{EHQZ}$	$t_{dis(E)}$		13		17		20	ns
6	$\overline{G}$ HIGH to Output in High-Z <sup>h</sup>	$t_{GHQZ}$	$t_{dis(G)}$		13		17		20	ns
7	$\overline{E}$ LOW to Output in Low-Z	$t_{ELQX}$	$t_{en(E)}$	5		5		5		ns
8	$\overline{G}$ LOW to Output in Low-Z	$t_{GLQX}$	$t_{en(G)}$	0		0		0		ns
9	Output Hold Time after Addr. Change <sup>g</sup>	$t_{AXQX}$	$t_{v(A)}$	3		3		3		ns
10	Chip Enable to Power Active <sup>e</sup>	$t_{ELICCH}$		0		0		0		ns
11	Chip Disable to Power Standby <sup>d, e</sup>	$t_{EHICCL}$			25		35		45	ns

e: Parameter guaranteed but not tested.

f: Device is continuously selected with  $\overline{E}$  and  $\overline{G}$  both LOW.

g: Address valid prior to or at the same time with  $\overline{E}$  transition LOW.

h: Measured  $\pm 200\text{ mV}$  from steady state output voltage.

## Read Cycle 1: Ai-controlled (during Read cycle: $\bar{E} = \bar{G} = V_{IL}$ , $\bar{W} = V_{IH}$ )<sup>f</sup>

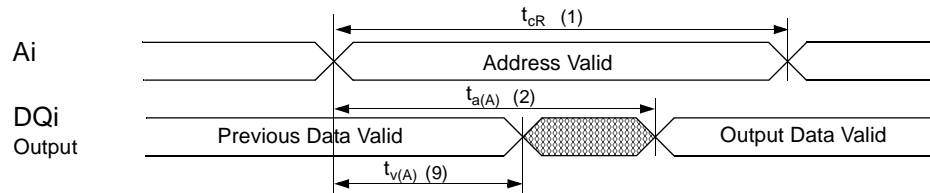

## Read Cycle 2: $\bar{G}$ -, $\bar{E}$ -controlled (during Read cycle: $\bar{W} = V_{IH}$ )<sup>g</sup>

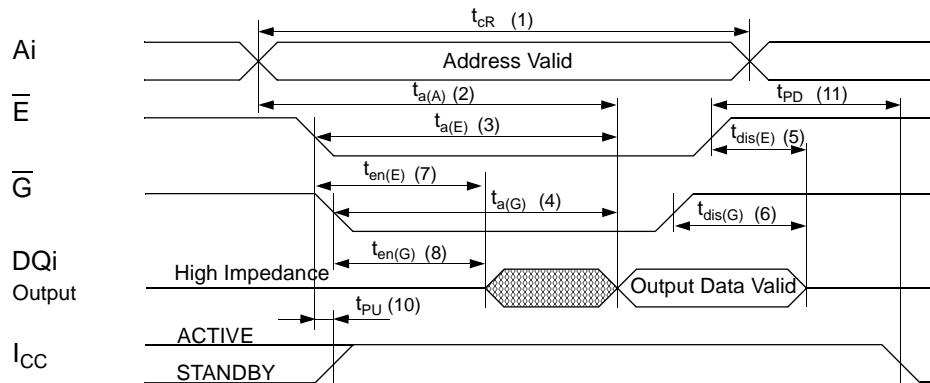

No.	Switching Characteristics Write Cycle	Symbol			25		35		45		Unit
		Alt. #1	Alt. #2	IEC	Min.	Max.	Min.	Max.	Min.	Max.	
12	Write Cycle Time	$t_{AVAV}$	$t_{AVAV}$	$t_{cW}$	25		35		45		ns
13	Write Pulse Width	$t_{WLWH}$		$t_{w(W)}$	20		30		35		ns
14	Write Pulse Width Setup Time		$t_{WLEH}$	$t_{su(W)}$	20		30		35		ns
15	Address Setup Time	$t_{AVWL}$	$t_{AVEL}$	$t_{su(A)}$	0		0		0		ns
16	Address Valid to End of Write	$t_{AVWH}$	$t_{AVEH}$	$t_{su(A-WH)}$	20		30		35		ns
17	Chip Enable Setup Time	$t_{ELWH}$		$t_{su(E)}$	20		30		35		ns
18	Chip Enable to End of Write		$t_{ELEH}$	$t_{w(E)}$	20		30		35		ns
19	Data Setup Time to End of Write	$t_{DVWH}$	$t_{DVEH}$	$t_{su(D)}$	12		18		20		ns
20	Data Hold Time after End of Write	$t_{WHDX}$	$t_{EHDX}$	$t_{h(D)}$	0		0		0		ns
21	Address Hold after End of Write	$t_{WHAX}$	$t_{EHAX}$	$t_{h(A)}$	0		0		0		ns
22	$\bar{W}$ LOW to Output in High-Z <sup>h, i</sup>	$t_{WLQZ}$		$t_{dis(W)}$		10		13		15	ns
23	$\bar{W}$ HIGH to Output in Low-Z	$t_{WHQX}$		$t_{en(W)}$	5		5		5		ns

# U631H16

## Write Cycle #1: $\overline{W}$ -controlled<sup>j</sup>

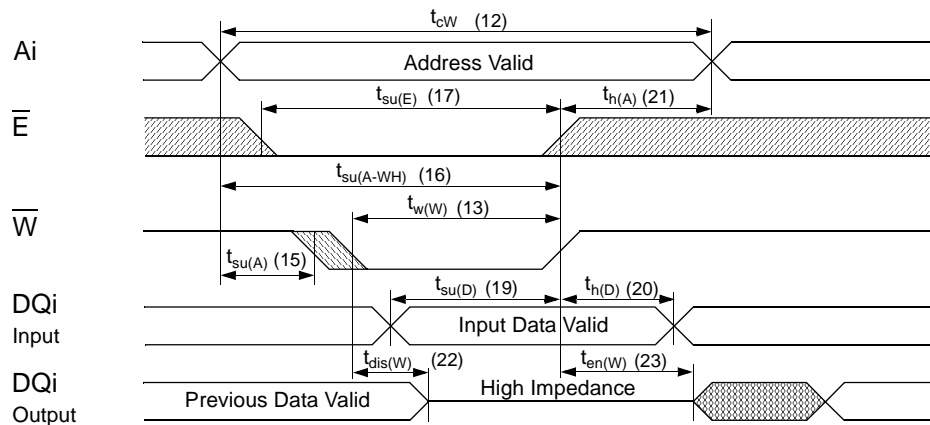

## Write Cycle #2: $\overline{E}$ -controlled

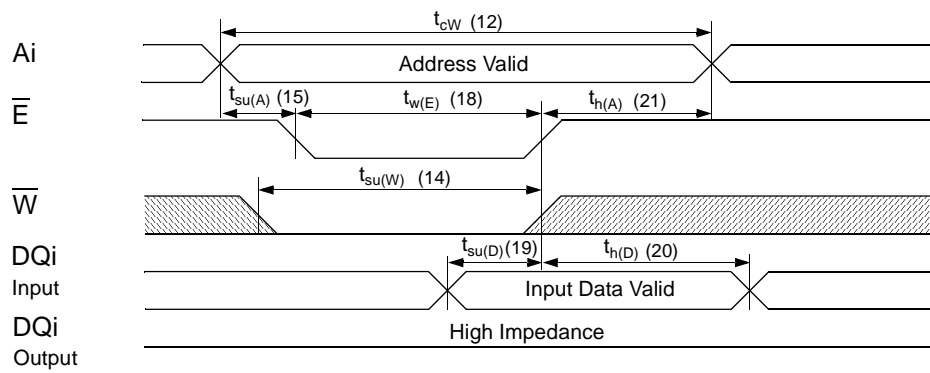

- i: If  $\overline{W}$  is LOW and when  $\overline{E}$  goes LOW, the outputs remain in the high impedance state.
- j:  $\overline{E}$  or  $\overline{W}$  must be  $\geq V_{IH}$  during address transitions.

## Nonvolatile Memory Operations

No.	STORE Cycle Inhibit and Automatic Power Up RECALL	Symbol		Min.	Max.	Unit
		Alt.	IEC			
24	Power Up RECALL Duration <sup>k, e</sup>	$t_{\text{RESTORE}}$			650	$\mu\text{s}$
	Low Voltage Trigger Level	$V_{\text{SWITCH}}$		4.0	4.5	V

k:  $t_{\text{RESTORE}}$  starts from the time  $V_{\text{CC}}$  rises above  $V_{\text{SWITCH}}$ .

## STORE Cycle Inhibit and Automatic Power Up RECALL

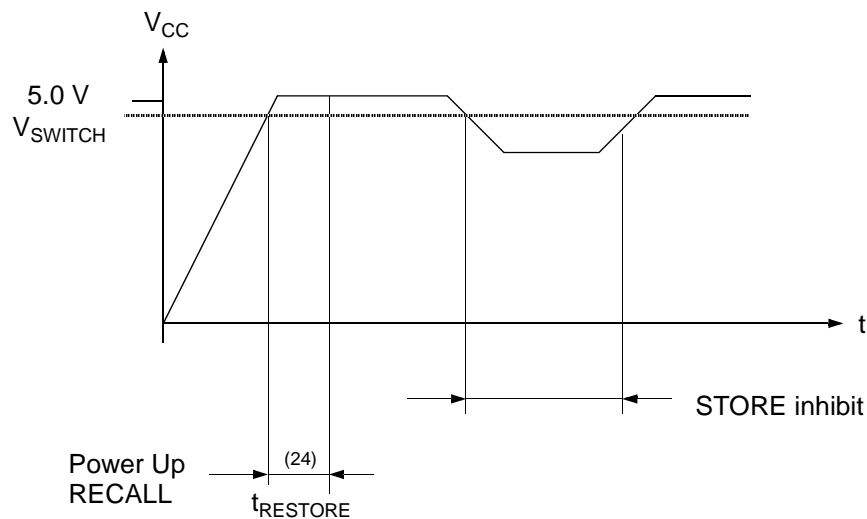

## Software Mode Selection

$\bar{E}$	$\bar{W}$	A10 - A0 (hex)	Mode	I/O	Power	Notes
L	H	000	Read SRAM	Output Data	Active	l, m
		555	Read SRAM	Output Data		l, m
		2AA	Read SRAM	Output Data		l, m
		7FF	Read SRAM	Output Data		l, m
		0F0	Read SRAM	Output Data		l, m
		70F	Nonvolatile STORE	Output High Z		$I_{\text{CC2}}$
L	H	000	Read SRAM	Output Data	Active	l, m
		555	Read SRAM	Output Data		l, m
		2AA	Read SRAM	Output Data		l, m
		7FF	Read SRAM	Output Data		l, m
		0F0	Read SRAM	Output Data		l, m
		70E	Nonvolatile RECALL	Output High Z		l

l: The six consecutive addresses must be in order listed (000, 555, 2AA, 7FF, 0F0, 70F) for a Store cycle or (000, 555, 2AA, 7FF, 0F0, 70E) for a RECALL cycle.  $\bar{W}$  must be high during all six consecutive cycles. See STORE cycle and RECALL cycle tables and diagrams for further details.

The following six-address sequence is used for testing purposes and should not be used: 000, 555, 2AA, 7FF, 0F0, 39C.

m: I/O state assumes that  $\bar{G} \leq V_{\text{IL}}$ . Activation of nonvolatile cycles does not depend on the state of  $\bar{G}$ .

No.	Software Controlled STORE/RECALL Cycle <sup>l, n</sup>	Symbol		25		35		45		Unit
		Alt.	IEC	Min.	Max.	Min.	Max.	Min.	Max.	
25	STORE/RECALL Initiation Time	$t_{AVAV}$	$t_{cR}$	25		35		45		ns
26	Chip Enable to Output Inactive <sup>o</sup>	$t_{ELQZ}$	$t_{dis(E)SR}$		600		600		600	ns
27	STORE Cycle Time <sup>p</sup>	$t_{ELQXS}$	$t_{d(E)S}$		10		10		10	ms
28	RECALL Cycle Time <sup>q</sup>	$t_{ELQXR}$	$t_{d(E)R}$		20		20		20	$\mu$ s
29	Address Setup to Chip Enable <sup>r</sup>	$t_{AVELN}$	$t_{su(A)SR}$	0		0		0		ns
30	Chip Enable Pulse Width <sup>r, s</sup>	$t_{ELEHN}$	$t_{w(E)SR}$	20		25		35		ns
31	Chip Disable to Address Change <sup>r</sup>	$t_{EHAXN}$	$t_{h(A)SR}$	0		0		0		ns

n: The software sequence is clocked with  $\bar{E}$  controlled READs.

o: Once the software controlled STORE or RECALL cycle is initiated, it completes automatically, ignoring all inputs.

p: Note that STORE cycles (but not RECALL) are aborted by  $V_{CC} < V_{SWITCH}$  (STORE inhibit).

q: An automatic RECALL also takes place at power up, starting when  $V_{CC}$  exceeds  $V_{SWITCH}$  and takes  $t_{RESTORE}$ .  $V_{CC}$  must not drop below  $V_{SWITCH}$  once it has been exceeded for the RECALL to function properly.

r: Noise on the  $\bar{E}$  pin may trigger multiple READ cycles from the same address and abort the address sequence.

s: If the Chip Enable Pulse Width is less than  $t_{a(E)}$  (see Read Cycle) but greater than or equal  $t_{w(E)SR}$ , then the data may not be valid at the end of the low pulse, however the STORE or RECALL will still be initiated.

### Software Controlled STORE/RECALL Cycle<sup>r, s, t, u</sup> ( $\bar{E}$ = HIGH after STORE initiation)

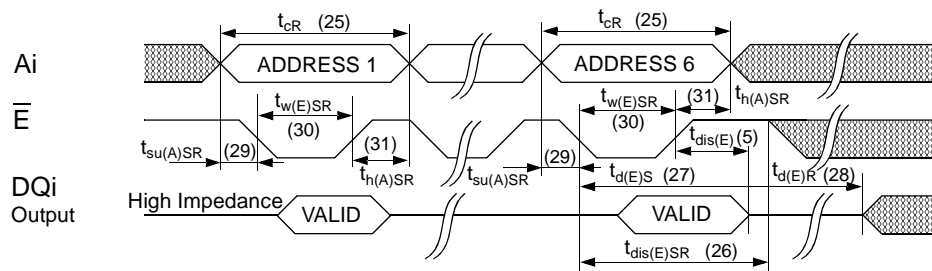

### Software Controlled STORE/RECALL Cycle<sup>r, s, t, u</sup> ( $\bar{E}$ = LOW after STORE initiation)

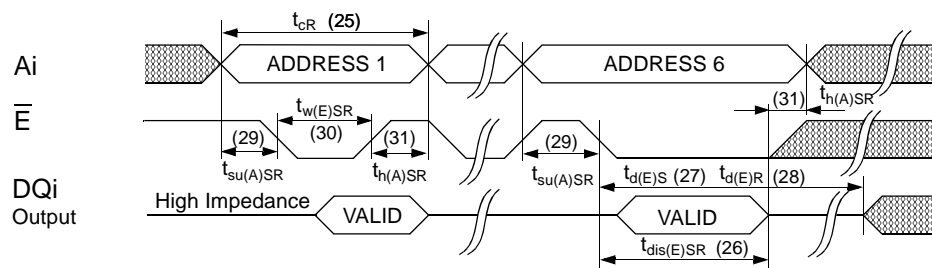

t:  $\bar{W}$  must be HIGH when  $\bar{E}$  is LOW during the address sequence in order to initiate a nonvolatile cycle.  $\bar{G}$  may be either HIGH or LOW throughout. Addresses 1 through 6 are found in the mode selection table. Address 6 determines whether the U631H16 performs a STORE or RECALL.

u:  $\bar{E}$  must be used to clock in the address sequence for the Software controlled STORE and RECALL cycles.



## Test Configuration for Functional Check

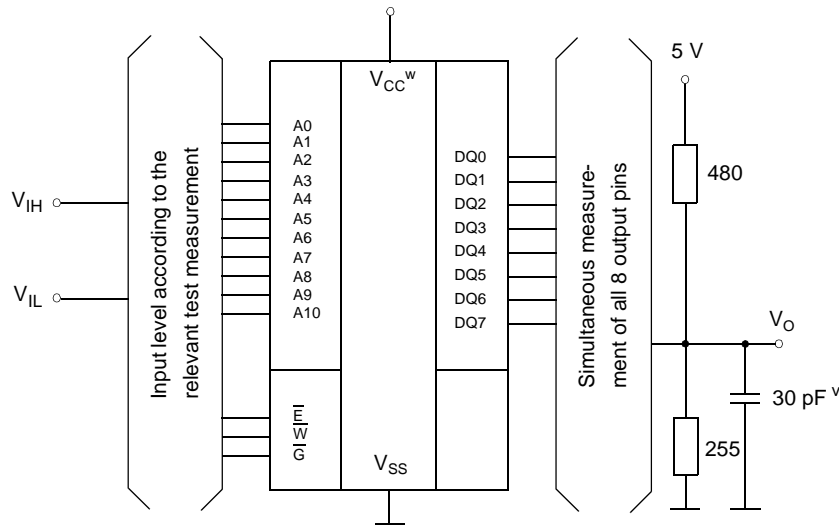

v: In measurement of  $t_{dis}$ -times and  $t_{en}$ -times the capacitance is 5 pF.

w: Between  $V_{CC}$  and  $V_{SS}$  must be connected a high frequency bypass capacitor 0.1  $\mu$ F to avoid disturbances.

Capacitance <sup>e</sup>	Conditions	Symbol	Min.	Max.	Unit
Input Capacitance	$V_{CC} = 5.0 \text{ V}$ $V_I = V_{SS}$	$C_I$		8	pF
Output Capacitance	$f = 1 \text{ MHz}$ $T_a = 25 \text{ }^\circ\text{C}$	$C_O$		7	pF

All pins not under test must be connected with ground by capacitors.

## Ordering Code

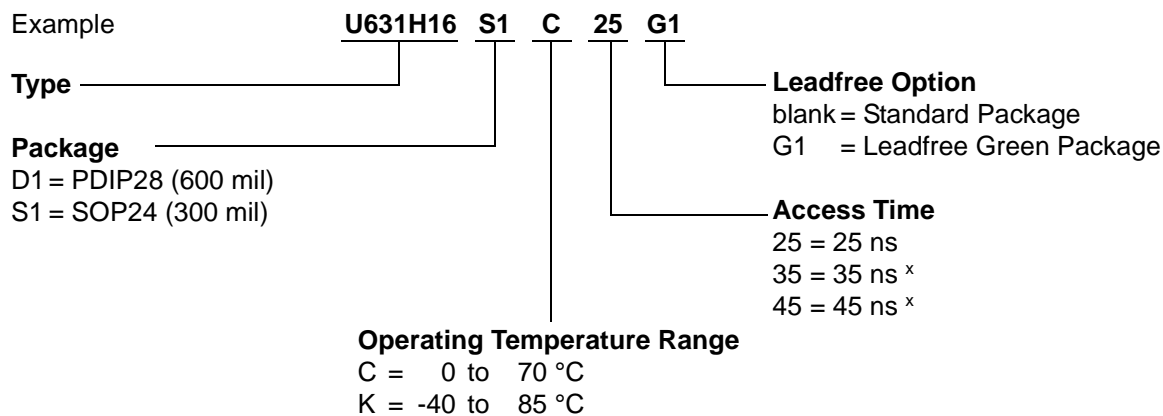

x: on special request

## Device Marking (example)

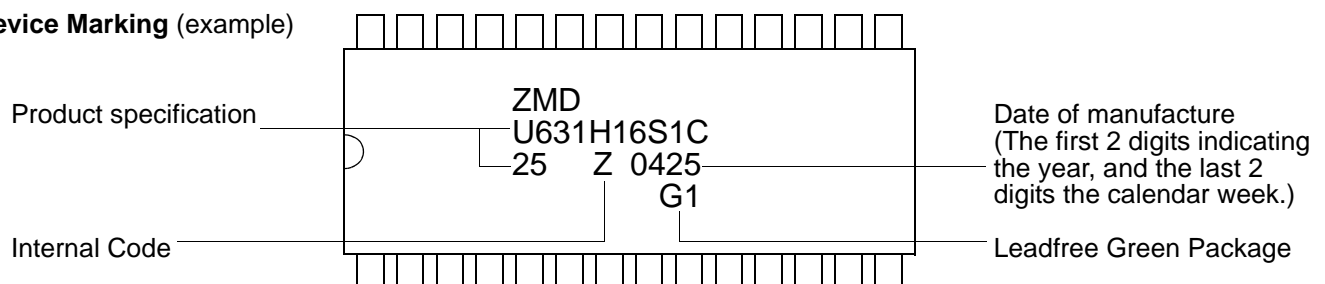

# U631H16

## Device Operation

The U631H16 has two separate modes of operation: SRAM mode and nonvolatile mode. In SRAM mode, the memory operates as a standard fast static RAM. In nonvolatile mode, data is transferred from SRAM to EEPROM (the STORE operation) or from EEPROM to SRAM (the RECALL operation). In this mode SRAM functions are disabled.

### SRAM READ

The U631H16 performs a READ cycle whenever  $\overline{E}$  and  $\overline{G}$  are LOW while  $\overline{W}$  is HIGH. The address specified on pins A0 - A10 determines which of the 2048 data bytes will be accessed. When the READ is initiated by an address transition, the outputs will be valid after a delay of  $t_{cR}$ . If the READ is initiated by  $\overline{E}$  or  $\overline{G}$ , the outputs will be valid at  $t_{a(E)}$  or at  $t_{a(G)}$ , whichever is later. The data outputs will repeatedly respond to address changes within the  $t_{cR}$  access time without the need for transition on any control input pins, and will remain valid until another address change or until  $\overline{E}$  or  $\overline{G}$  is brought HIGH or  $\overline{W}$  is brought LOW.

### SRAM WRITE

A WRITE cycle is performed whenever  $\overline{E}$  and  $\overline{W}$  are LOW. The address inputs must be stable prior to entering the WRITE cycle and must remain stable until either  $\overline{E}$  or  $\overline{W}$  goes HIGH at the end of the cycle. The data on pins DQ0 - 7 will be written into the memory if it is valid  $t_{su(D)}$  before the end of a  $\overline{W}$  controlled WRITE or  $t_{su(D)}$  before the end of an  $\overline{E}$  controlled WRITE. It is recommended that  $\overline{G}$  is kept HIGH during the entire WRITE cycle to avoid data bus contention on the common I/O lines. If  $\overline{G}$  is left LOW, internal circuitry will turn off the output buffers  $t_{dis(W)}$  after  $\overline{W}$  goes LOW.

### Noise Consideration

The U631H16 is a high speed memory and therefore it must have a high frequency bypass capacitor of approximately 0.1  $\mu$ F connected between  $V_{CC}$  and  $V_{SS}$  using leads and traces that are as short as possible. As with all high speed CMOS ICs, normal careful routing of power, ground and signals will help prevent noise problems.

### Software Nonvolatile STORE

The U631H16 software controlled STORE cycle is initiated by executing sequential READ cycles from six specific address locations. By relying on READ cycles only, the U631H16 implements nonvolatile operation while remaining compatible with standard 2K x 8 SRAMs. During the STORE cycle, an erase of the previous nonvolatile data is first

performed, followed by parallel programming of all non-volatile elements. Once a STORE cycle is initiated, further inputs and outputs are disabled until the cycle is completed.

Because a sequence of addresses is used for STORE initiation, it is important that no other READ or WRITE accesses intervene in the sequence or the sequence will be aborted and no STORE or RECALL will take place.

To initiate the STORE cycle the following READ sequence must be performed:

1. Read address 000 (hex) Valid READ
2. Read address 555 (hex) Valid READ
3. Read address 2AA (hex) Valid READ
4. Read address 7FF (hex) Valid READ
5. Read address 0F0 (hex) Valid READ
6. Read address 70F (hex) Initiate STORE

Once the sixth address in the sequence has been entered, the STORE cycle will commence and the chip will be disabled. It is important that READ cycles and not WRITE cycles are used in the sequence. It is not necessary that  $\overline{G}$  is LOW for the sequence to be valid. After the  $t_{STORE}$  cycle time has been fulfilled, the SRAM will again be activated for READ and WRITE operation.

### Software Nonvolatile RECALL

A RECALL cycle of the EEPROM data into the SRAM is initiated with a sequence of READ operations in a manner similar to the STORE initiation. To initiate the RECALL cycle the following sequence of READ operations must be performed:

1. Read address 000 (hex) Valid READ
2. Read address 555 (hex) Valid READ
3. Read address 2AA (hex) Valid READ
4. Read address 7FF (hex) Valid READ
5. Read address 0F0 (hex) Valid READ
6. Read address 70E (hex) Initiate RECALL

Internally, RECALL is a two step procedure. First, the SRAM data is cleared and second, the nonvolatile information is transferred into the SRAM cells. The RECALL operation in no way alters the data in the EEPROM cells. The nonvolatile data can be recalled an unlimited number of times.

### Automatic Power Up RECALL

On power up, once  $V_{CC}$  exceeds the sense voltage of  $V_{SWITCH}$ , a RECALL cycle is automatically initiated. The voltage on the  $V_{CC}$  pin must not drop below  $V_{SWITCH}$  once it has risen above it in order for the RECALL to operate properly. Due to this automatic RECALL, SRAM operation cannot commence until  $t_{RESTORE}$  after  $V_{CC}$  exceeds  $V_{SWITCH}$ .

If the U631H16 is in a WRITE state at the end of power up RECALL, the SRAM data will be corrupted. To help avoid this situation, a 10 K $\Omega$  resistor should be connected between  $\overline{W}$  and  $V_{CC}$ .

## Hardware Protection

The U631H16 offers hardware protection against inadvertent STORE operation through  $V_{CC}$  sense. For  $V_{CC} < V_{SWITCH}$  the software initiated STORE operation will be inhibited.

## Low Average Active Power

The U631H16 has been designed to draw significantly less power when  $\overline{E}$  is LOW (chip enabled) but the access cycle time is longer than 55 ns.

When  $\overline{E}$  is HIGH the chip consumes only standby current.

The overall average current drawn by the part depends on the following items:

1. CMOS or TTL input levels
2. the time during which the chip is disabled ( $\overline{E}$  HIGH)
3. the cycle time for accesses ( $\overline{E}$  LOW)
4. the ratio of READs to WRITEs
5. the operating temperature
6. the  $V_{CC}$  level

The information describes the type of component and shall not be considered as assured characteristics. Terms of delivery and rights to change design reserved.

## **LIFE SUPPORT POLICY**

Simtek products are not designed, intended, or authorized for use as components in systems intended for surgical implant into the body, or other applications intended to support or sustain life, or for any other application in which the failure of the Simtek product could create a situation where personal injury or death may occur.

Components used in life-support devices or systems must be expressly authorized by Simtek for such purpose.

## **LIMITED WARRANTY**

The information in this document has been carefully checked and is believed to be reliable. However, Simtek makes no guarantee or warranty concerning the accuracy of said information and shall not be responsible for any loss or damage of whatever nature resulting from the use of, or reliance upon it. The information in this document describes the type of component and shall not be considered as assured characteristics.

Simtek does not guarantee that the use of any information contained herein will not infringe upon the patent, trademark, copyright, mask work right or other rights of third parties, and no patent or licence is implied hereby. This document does not in any way extend Simtek's warranty on any product beyond that set forth in its standard terms and conditions of sale.

Simtek reserves terms of delivery and reserves the right to make changes in the products or specifications, or both, presented in this publication at any time and without notice.

# Change record

Date/Rev	Name	Change
01.11.2001	Ivonne Steffens	format revision and release for „Memory CD 2002“
20.04.2004	Matthias Schniebel	adding „Leadfree Green Package“ to ordering information adding „Device Marking“
7.4.2005	Stefan Günther	delete PDIP28 (300mil) and SOP28 (300mil), add $10^6$ endurance cycles and 100a data retention and ESD protection > 2000V
31.3.2006	Troy Meester	changed to obsolete status
1.0	Simtek	Assigned Simtek Document Control Number