

**VI TELEFILTER****Specification****TFS 82 A - 1/4****Measurement condition**

Ambient temperature: 23 °C  
 Input power level: 0 dBm  
 Terminating impedances  
   for input: 960Ω || -2 pF  
   for output: 960Ω || -2 pF

**Package, pin connection and 50 Ω matching network**

see sheet 2

**Characteristics****Remark:**

Reference level for the relative attenuation  $a_{rel}$  of the TFS 82 A is the minimum of the pass band attenuation  $a_{min}$ . The minimum of the pass band attenuation  $a_{min}$  is defined as the insertion loss  $a_e$ . The centre frequency  $f_o$  is the arithmetic mean value of the upper and lower frequencies at the 3 dB filter attenuation level relative to the insertion loss  $a_e$ . The nominal frequency  $f_N$  is fixed on 82,8 MHz without tolerance. The given values for the relative attenuation  $a_{rel}$  and for the group delay ripple have to be reached at the frequencies given below also if the centre frequency  $f_o$  is shifted due to the temperature coefficient of frequency  $TC_f$  in the operating temperature range and due to a production tolerance for the centre frequency  $f_o$ .

<b>D a t a</b>		<b>typ. value</b>	<b>tolerance / limit</b>
<b>Insertion loss</b> (Reference level)	$a_e = a_{min}$	-	max 4 dB
<b>Nominal frequency</b>	$f_N$	-	82,8 MHz
<b>Centre frequency</b>	$f_o$	82,8 MHz	-
<b>Relative attenuation</b>	$a_{rel}$		
$f_N \pm 12$ kHz			max. 3 dB
$f_N - 1000$ kHz ... $f_N - 400$ kHz		-	min. 60 dB
$f_N - 400$ kHz ... $f_N - 200$ kHz		-	min. 50 dB
$f_N - 200$ kHz ... $f_N - 120$ kHz		-	min. 40 dB
$f_N - 120$ kHz ... $f_N - 60$ kHz		-	min. 20 dB
$f_N + 60$ kHz ... $f_N + 120$ kHz		-	min. 20 dB
$f_N + 120$ kHz ... $f_N + 500$ kHz		-	min. 39 dB
$f_N + 500$ kHz ... $f_N + 1000$ kHz		-	min. 50 dB
<b>Group delay distortion</b>	GDD		
$f_N \pm 8$ kHz		-	max. 10 μs
<b>Operating temperature range</b>		- 30 °C ... + 60 °C	
<b>Storage temperature range</b>		- 40 °C ... + 85 °C	
<b>Temperature coefficient of frequency</b>	$TC_f$	ca. - 0,036 ppm/K <sup>2</sup>	
<b>Frequency inversion temperature</b>		+ 20 °C	-
<b>Permissible DC voltage</b>	$V_{DC}$	-	max. 10 V

**Generated:****Checked / approved:**

**VI TELEFILTER**  
 Potsdamer Straße 18  
 D 14 513 TELTOW / Germany  
 Tel: (+49) 3328 4784-52 / Fax: (+49) 3328 4784-30  
 E-Mail: tft@telefilter.com

**Vectron Technologies, Inc.**  
 267 Lowell Road  
 Hudson, NH 03051 / USA  
 Tel: (603) 598-0070 Fax: (603) 598-0075  
 E-Mail: vti@vtinh.com

**VI TELEFILTER****Specification****TFS 82 A - 2/4****Package, pin configuration and 50 Ω matching network**

Dimensions in mm

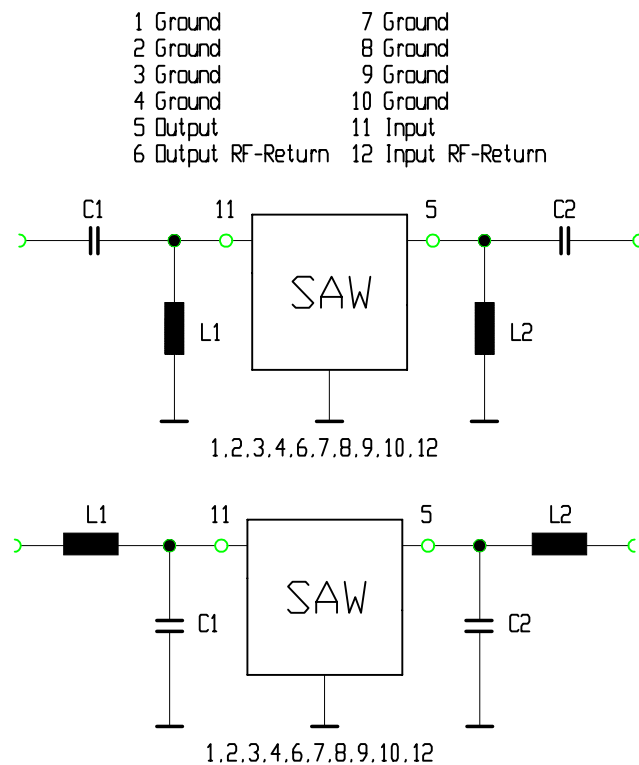
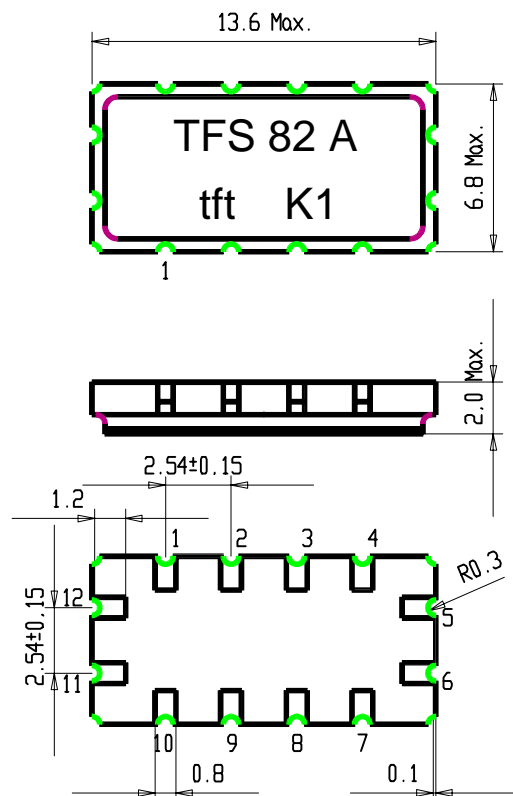

**VI TELEFILTER**  
 Potsdamer Straße 18  
 D 14 513 TELTOW / Germany  
 Tel: (+49) 3328 4784-52 / Fax: (+49) 3328 4784-30  
 E-Mail: tft@telefilter.com

**Vectron Technologies, Inc.**  
 267 Lowell Road  
 Hudson, NH 03051 / USA  
 Tel: (603) 598-0070 Fax: (603) 598-0075  
 E-Mail: vti@vtinh.com

**VI TELEFILTER****Specification****TFS 82 A - 3/4****Stability Characteristics**

After the following tests the filter shall meet the whole specification:

1. Shock: 100g, 18 ms, half sine wave, 3 shocks each plane;  
DIN IEC 68 T2 - 27
2. Vibration: 10 Hz to 500 Hz, 0,075 mm or 1g respectively, 1 octave per min, 10 cycles per plan, 3 plans;  
DIN IEC 68 T2 - 6
3. Damp heat: 90 % to 95 % rel. humidity, 40 °C, 10 days;  
(steady state) DIN IEC 68 - 2 - 3
4. Resistance to solder heat (reflow): max. 2 times reflow process;  
for temperature conditions refer to the attached "Air reflow temperature conditions" on sheet 4;

**Packing**

Tape & Reel: IEC 286 - 3, with exception of value for N and minimum bending radius;  
tape type II, embossed carrier tape with top cover tape on the upper side;  
max. pieces of filters per reel: 1700

**Tape (all dimensions in mm)**

W	: 24 ± 0,3
Po	: 4 ± 0,1
Do	: 1,5 + 0,5
D1	: 1,5 + 0,5
E	: 1,75 ± 0,1
F	: 11,5 ± 0,1
G (min)	: 0,75
P2	: 2 ± 0,1
P1	: 12 ± 0,1
D1(min)	: 1,5
Ao	: 7,1 ± 0,2
Bo	: 13,9 ± 0,2

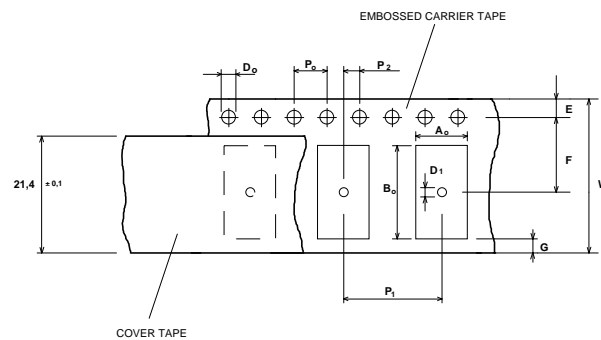
**Reel (all dimensions in mm):**

A	:	330
W1	:	16,4 +2
W2 (max)	:	22,4
N (min)	:	>= 90
C	:	13 ± 0,25

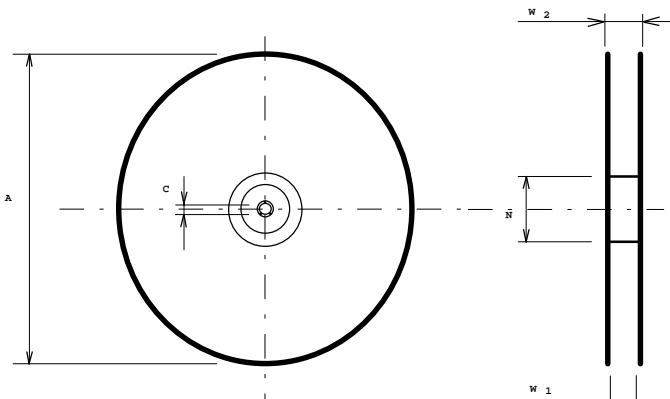

The minimum bending radius is 45 mm. The mounting surface of the filters faces the bottom side of the embossed carrier tape. The marking of the filters is able to read if the view is directed on the upper side of the carrier tape with the sprocket holes on the right side of the tape.

**VI TELEFILTER**

Potsdamer Straße 18  
D 14 513 TELTOW / Germany  
Tel: (+49) 3328 4784-52 / Fax: (+49) 3328 4784-30  
E-Mail: tft@telefilter.com

**Vectron Technologies, Inc.**

267 Lowell Road  
Hudson, NH 03051 / USA  
Tel: (603) 598-0070 Fax: (603) 598-0075  
E-Mail: vti@vtinh.com

**VI TELEFILTER****Specification****TFS 82 A - 4/4****Air reflow temperature conditions**

## 1st and 2nd air reflow profile

Name:	pre-heating periods	main-heating periods	peak temperature
Temperature:	150 °C - 170 °C	over 200 °C	255 °C ± 5 °C
Time:	60 sec. - 90 sec.	20 sec. - 25 sec.	

**Chip-mount air reflow profile**

Table for temperature vs. time during the air reflow process

Tolerance of temperatures: ± 5 °C

time / sec.	temperature / °C	time / sec.	temperature / °C
0	23	140	160
10	34	150	161
20	46	160	164
30	60	170	170
40	80	180	180
50	103	190	205
60	121	195	230
70	134	200	255
80	143	205	230
90	150	210	205
100	154	215	180
110	156	220	165
120	158	230	140
130	159	240	120

**VI TELEFILTER**  
 Potsdamer Straße 18  
 D 14 513 TELTOW / Germany  
 Tel: (+49) 3328 4784-52 / Fax: (+49) 3328 4784-30  
 E-Mail: tft@telefilter.com

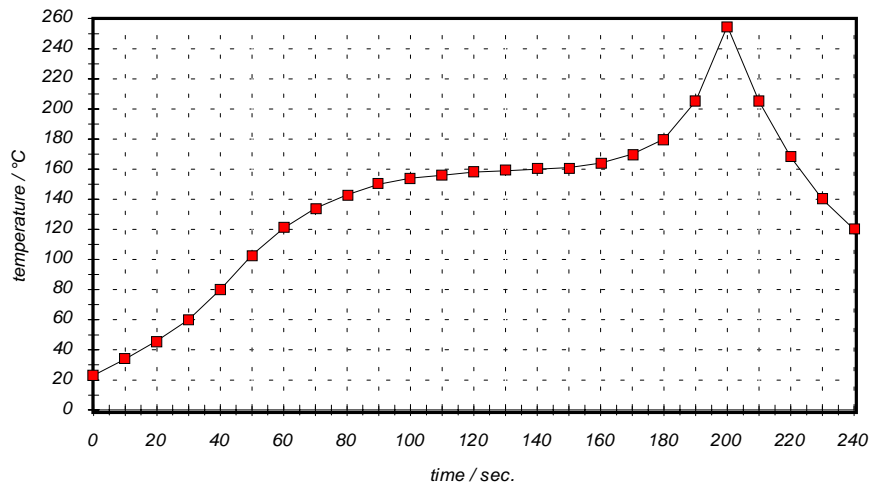
**Vectron Technologies, Inc.**  
 267 Lowell Road  
 Hudson, NH 03051 / USA  
 Tel: (603) 598-0070 Fax: (603) 598-0075  
 E-Mail: vti@vtinh.com