

VI TELEFILTER**Filter specification****TFS 460 C 1/3****Measurement condition**

Ambient temperature: 23 °C
 Input power level: 0 dBm
 Source impedance: 184 Ω || -0.33 pF
 Load impedance: 184 Ω || -0.33 pF

Construction and pin connection (see page 2)

Characteristics**Remark:**

Reference level for the relative attenuation a_{rel} of the TFS 460 C is the minimum of the pass band attenuation a_{min} . The minimum of the pass band attenuation a_{min} is defined as the insertion loss a_e . The centre frequency f_o is the arithmetic mean value of the upper and lower frequencies at the 3dB filter attenuation level relative to the insertion loss a_e . The nominal frequency f_N is fixed on 460 MHz without tolerance. The given values for the relative attenuation a_{rel} and for the group delay ripple have to be reached at the frequencies given below also if the centre frequency f_o is shifted due to the temperature coefficient of frequency TC_f in the operating temperature range and due to a production tolerance for the centre frequency f_o

D a t a		typ. value		tolerance / limit	
Insertion loss (Reference level)	$a_e = a_{min}$	3	dB	max 5	dB
Nominal frequency	f_N	-		460	MHz
Centre frequency	f_o	460	MHz	-	
Pass band ripple					
$f_N \pm 10$ MHz		1	dB	max. 2	dB
Relative attenuation a_{rel}					
360 MHz ... 380 MHz		60	dB	min. 50	dB
405 MHz ... 425 MHz		> 40	dB	min. 40	dB
Operating temperature range			- 25 °C ... + 75 °C		
Temperature coefficient of frequency	TC	- 71	ppm/K		

Generated: _____

Checked / approved: _____

VI TELEFILTER
 Potsdamer Straße 18
 D 14 513 TELTOW / Germany
 Tel: (+49) 3328 4784-52 / Fax: (+49) 3328 4784-30
 E-Mail: tft@telefilter.com

Vectron International, Inc.
 267 Lowell Road
 Hudson, NH 03051 / USA
 Tel: (603) 598-0070 Fax: (603) 598-0075
 E-Mail: vti@vtinh.com

VI TELEFILTER reserves the right to make changes to the product(s) and/or information contained herein without notice. No liability is assumed as a result of their use or application. No rights under any patent accompany the sale of any such product(s) or information.

Construction and pin connection

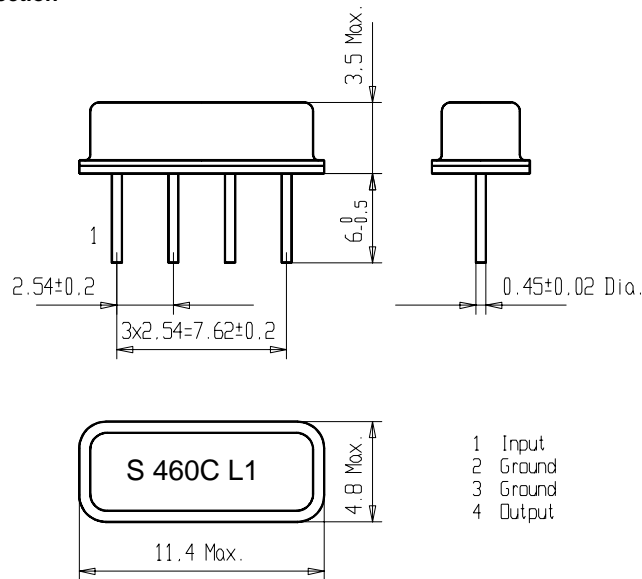

50 Ω test circuit 1 *)

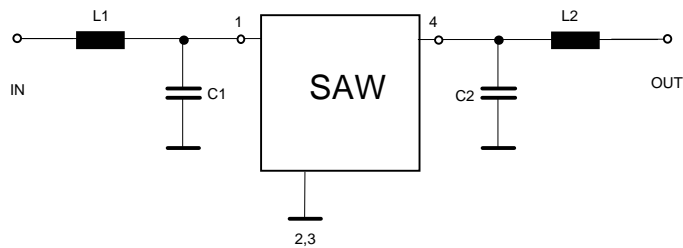

50 Ω test circuit 2 *)

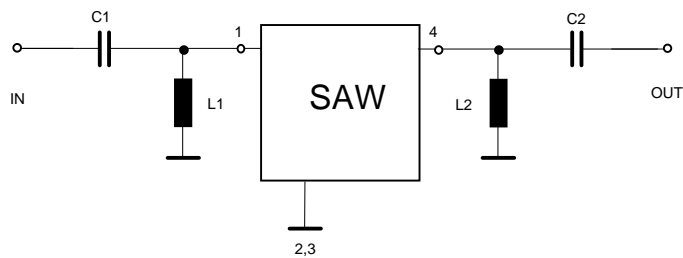

*) Both circuits are possible, but the behavior of the first circuit differs slightly from the second one. The final test at Telefilter is carried out with the first circuit.

Air reflow temperature conditions

1st and 2nd air reflow profile

Name:	pre-heating periods	main-heating periods	peak temperature
Temperature:	150 °C - 170 °C	over 200 °C	255 °C ± 5 °C
Time:	60 sec. - 90 sec.	20 sec. - 25 sec.	

Chip-mount air reflow profile

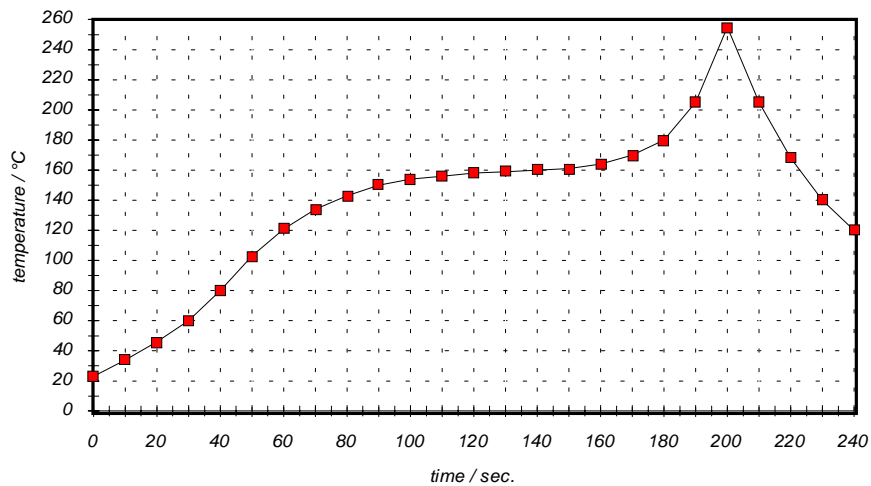

Table for temperature vs. time during the air reflow process

Tolerance of temperatures: ± 5 °C			
time / sec.	temperature / °C	time / sec.	temperature / °C
0	23	140	160
10	34	150	161
20	46	160	164
30	60	170	170
40	80	180	180
50	103	190	205
60	121	195	230
70	134	200	255
80	143	205	230
90	150	210	205
100	154	215	180
110	156	220	165
120	158	230	140
130	159	240	120