

VI TELEFILTER**Filter specification****TFS 210 E****1/4****Measurement Condition**

Ambient Temperature:	23 °C
Input Power Level:	0 dBm
Source impedance:	50 Ω single ended
Load impedance:	50 Ω single ended
Terminating impedances:	
input:	630 Ω -9.2 pF
output:	915 Ω -5.7pF

Construction, pin connection and 50 Ω test circuit

see page 2

Stability characteristics and packing

see page 3

Air reflow temperature conditions

see page 4

Characteristics**Remark:**

Reference level for the relative attenuation a_{rel} is the minimum of the pass band attenuation a_{min} . The minimum of the pass band attenuation a_{min} is defined as the insertion loss a_e . The nominal frequency f_N is fixed to 210,38 MHz. The given values for the relative attenuation a_{rel} and for the phase ripple have to be reached at the frequencies given below also if the centre frequency f_0 is shifted due to the temperature coefficient of frequency TC_f in the operating temperature range and due to a production tolerance for the centre frequency f_0 .

D a t a		typ. Value	Limit
Insertion Loss (Reference level)	$a_e = a_{min}$	8 dB	max. 10 dB
Nominal Frequency	f_N	-	210,38 MHz
5 dB - Bandwidth	BW	1,6 MHz	min. 1,26 MHz
Relative Attenuation	a_{rel}		
$f_N \pm 0,63$ MHz		-	max. 5 dB
$f_N \pm 1,25$ MHz ... $f_N \pm 20$ MHz		-	min. 35 dB
$f_N - 1,25$ MHz		45 dB	min. 35 dB
$f_N + 1,25$ MHz		45 dB	min. 35 dB
$f_N \pm 2,05$ MHz		40 dB	min. 37 dB
Pass Band Ripple			
$f_N \pm 0,300$ MHz	-	0,3 dB	max. 1,2 dB
Phase linearity		φ	
$f_N \pm 0,300$ MHz	-	0,5 °rms	max. 1,5 °rms
$f_N \pm 0,630$ MHz	-	2,9 °rms	max. 3,75 °rms
Operating Temperature Range			- 30 °C ... + 80 °C

Generated: _____**Checked / approved:** _____

VI TELEFILTER
 Potsdamer Straße 18
 D 14 513 TELTOW / Germany
 Tel: (+49) 3328 4784-52 / Fax: (+49) 3328 4784-30
 E-Mail: tft@telefilter.com

Vectron International, Inc.
 267 Lowell Road
 Hudson, NH 03051 / USA
 Tel: (603) 598-0070 Fax: (603) 598-0075
 E-Mail: vti@vtin.com

Construction and pin connection

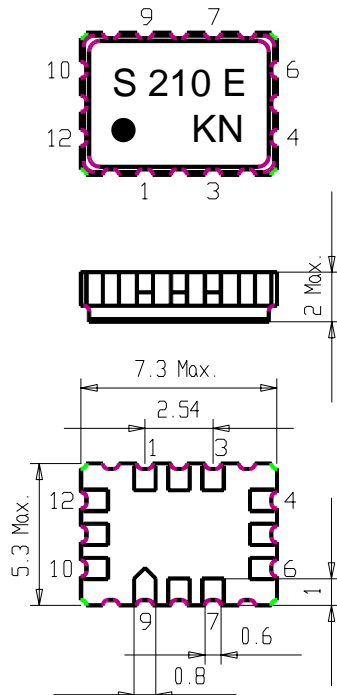

1	Ground
2	Ground
3	Output RF Return
4	Output
5	Ground
6	Ground
7	Ground
8	Ground
9	Input RF Return
10	Input
11	Ground
12	Ground

50 Ω single ended test circuit

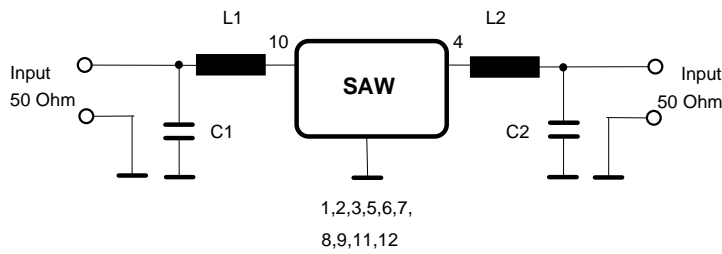

VI TELEFILTER
 Potsdamer Straße 18
 D 14 513 TELTOW / Germany
 Tel: (+49) 3328 4784-52 / Fax: (+49) 3328 4784-30
 E-Mail: tft@telefilter.com

Vectron International, Inc.
 267 Lowell Road
 Hudson, NH 03051 / USA
 Tel: (603) 598-0070 Fax: (603) 598-0075
 E-Mail: vti@vtinh.com

VI TELEFILTER**Filter specification****TFS 210 E****3/4****Stability characteristics**

After the following tests the filter shall meet the whole specification:

1. Shock: 30g, 18 ms, half sine wave, 3 shocks each plane;
DIN IEC 68 T2 - 27
2. Vibration: 10 Hz to 150 Hz, 0.35 mm amplitude, 5g; 2 hours for 3 planes;
DIN IEC 68 T2 - 6
3. Damp heat:
(steady state) 90 % to 95 % rel. humidity, 40 °C, 10 days;
DIN IEC 68 - 2 - 3
4. Resistance to
solder heat (reflow): max. 2 times reflow process;
for temperature conditions refer to the attached "Air reflow temperature conditions" on sheet 4;

Packing

Tape & Reel: IEC 286 - 3, with exception of value for N and minimum bending radius;
tape type II, embossed carrier tape with top cover tape on the upper side;

max. pieces of filters per reel: 3400

Tape (all dimensions in mm)

W	: 16 ± 0,3
Po	: 4 ± 0,1
Do	: 1,5 + 0,5
D1	: 1,5 + 0,5
E	: 1,75 ± 0,1
F	: 7,5 ± 0,1
G (min)	: 0,75
P2	: 2 ± 0,05
P1	: 8 ± 0,1
D1(min)	: 1,5
Ao	: 5,4 ± 0,1
Bo	: 7,4 ± 0,1

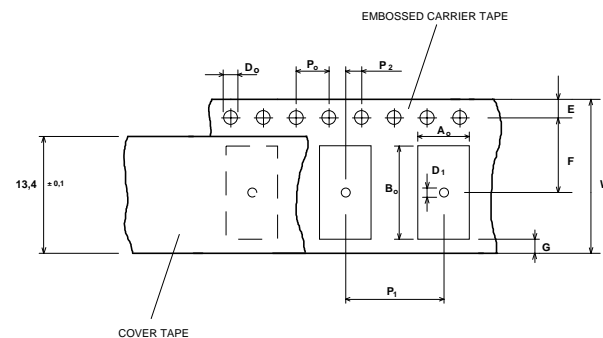
**Reel (all dimensions in mm):**

A	:	330
W1	:	16,4 +2
W2 (max)	:	22,4
N (min)	:	>= 90
C	:	13 ± 0,25

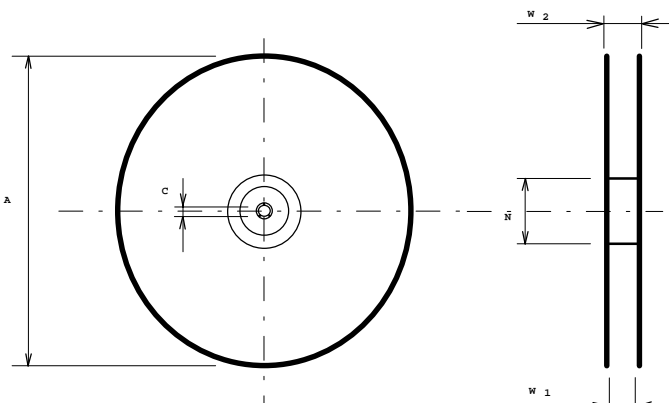

The minimum bending radius is 45 mm. The mounting surface of the filters faces the bottom side of the embossed carrier tape. The marking of the filters is able to read if the view is directed on the upper side of the carrier tape with the sprocket holes on the right side of the tape.

VI TELEFILTER**Potsdamer Straße 18****D 14 513 TELTOW / Germany****Tel: (+49) 3328 4784-52 / Fax: (+49) 3328 4784-30****E-Mail: tft@telefilter.com****Vectron International, Inc.****267 Lowell Road****Hudson, NH 03051 / USA****Tel: (603) 598-0070 Fax: (603) 598-0075****E-Mail: vti@vtinh.com**

Air Reflow Temperature Conditions

1st and 2nd air reflow profile

Name:	pre-heating periods	main-heating periods	peak temperature
Temperature:	150 °C - 170 °C	over 200 °C	255 °C ± 5 °C
Time:	60 sec. - 90 sec.	20 sec. - 25 sec.	

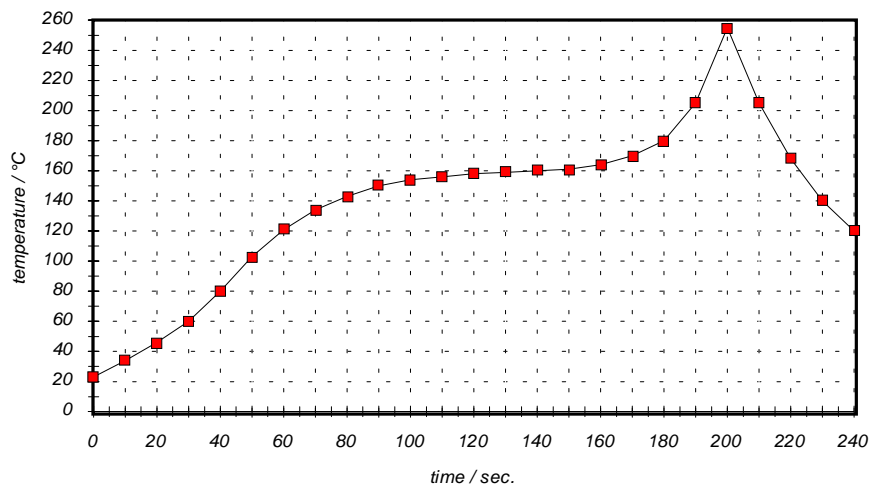
Chip-mount air reflow profile

Table for temperature vs. time during the air reflow process

Tolerance of temperatures: ± 5 °C

<u>time / sec.</u>	<u>temperature / °C</u>	<u>time / sec.</u>	<u>temperature / °C</u>
0	23	140	160
10	34	150	161
20	46	160	164
30	60	170	170
40	80	180	180
50	103	190	205
60	121	195	230
70	134	200	255
80	143	205	230
90	150	210	205
100	154	215	180
110	156	220	165
120	158	230	140
130	159	240	120