

VI TELEFILTER**Filter Specification****TFS 125 A - Page 1 / 4****Measurement condition**

Ambient temperature: 23 °C
 Input power level: 0 dBm
 Terminating impedances: 50 Ω

Stability Characteristics and Packing

See page 3

Air Reflow Temperature Conditions

See page 4

Construction, pin connection and recommended land dimensions

See page 2

Characteristics

Remark:

Reference level for the relative attenuation a_{rel} of the TFS 125 A is the maximum attenuation in the passband. The maximum attenuation in the pass band is defined as the insertion loss a_e . The nominal frequency f_N is fixed at 125 MHz without tolerance or limit. The values of relative attenuation a_{rel} are guaranteed in the whole operating temperature range. The frequency shift of the filter in the operating temperature range is included in the production tolerance scheme.

D a t a		typ. value		tolerance / limit	
Insertion loss (Reference level)	a_e	-		1,5 ... 3,5	dB
Nominal frequency	f_N	-		125	MHz
1 dB bandwidth	BW	-		min 300	kHz
Relative attenuation	a_{rel}				
$f_N - 150$ kHz ... $f_N + 150$ kHz		-		max. 1	dB
1 MHz ... $f_N - 28$ MHz		-		min. 12	dB
$f_N - 28$ MHz ... $f_N - 14$ MHz		-		min. 5	dB
$f_N + 14$ MHz ... $f_N + 28$ MHz		-		min. 15	dB
$f_N + 28$ MHz ... $f_N + 325$ MHz		-		min. 38	dB
VSWR					
$f_N - 150$ kHz ... $f_N + 150$ kHz		-		max 2 : 1	
Absolute group delay	GD				
f_N		-		max. 300	ns
Group delay ripple	GDD (**)				
$f_N - 150$ kHz ... $f_N + 150$ kHz		-		max 30	ns
Intermodulation	***)				
IP ₃		54	dB	min. 45	dB
Input power level				max. 10	dBm
Temperature coefficient of frequency	TC _f *)	- 71.6	ppm/K	-	
Operating temperature range				- 10 °C ... + 85 °C	

*) $\Delta f(\text{Hz}) = TC_f(\text{ppm/K}) \times (\Delta T) \times f_{T0}(\text{MHz})$

**) measured with smoothing; smoothing aperture ≤ 50 kHz

***) modulation signals: f_N and $f_N + 14$ MHz, each of 10 dBm; measured signal: $f_N - 14$ MHz

generated: _____

checked / approved: _____

VI TELEFILTER
 Potsdamer Straße 18
 D 14 513 TELTOW / Germany
 Tel: (+49) 3328 4784-52 / Fax: (+49) 3328 4784-30
 E-Mail: tft@telefilter.com

Vectron International, Inc.
 267 Lowell Road
 Hudson, NH 03051 / USA
 Tel: (603) 598-0070 Fax: (603) 598-0075
 E-Mail: vti@vtinh.com

Construction and pin connection

(All dimensions in mm)

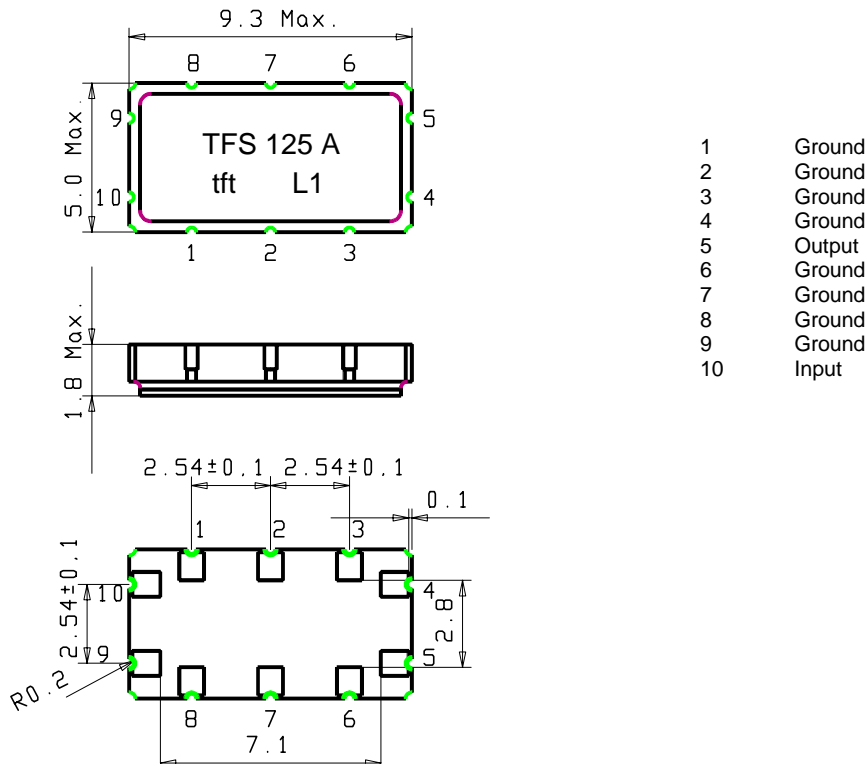
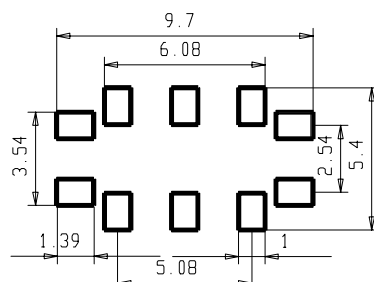
**Recommended land dimensions**

VI TELEFILTER
 Potsdamer Straße 18
 D 14 513 TELTOW / Germany
 Tel: (+49) 3328 4784-52 / Fax: (+49) 3328 4784-30
 E-Mail: tft@telefilter.com

Vectron International, Inc.
 267 Lowell Road
 Hudson, NH 03051 / USA
 Tel: (603) 598-0070 Fax: (603) 598-0075
 E-Mail: vti@vtinh.com

Stability Characteristics

After the following tests the filter shall meet the whole specification:

1. Shock: 100g, 18 ms, half sine wave, 3 shocks each plane;
DIN IEC 68 T2 - 27
2. Vibration: 10 Hz to 500 Hz, 0,075 mm or 1g respectively, 1 octave per min, 10 cycles per plan, 3 plans;
DIN IEC 68 T2 - 6
3. Damp heat: 90 % to 95 % rel. humidity, 40 °C, 10 days;
(steady state) DIN IEC 68 - 2 - 3
4. Resistance to solder heat (reflow): max. 2 times reflow process;
for temperature conditions refer to the attached "Air reflow temperature conditions" on sheet 4;

Packing

Tape & Reel: IEC 286 - 3, with exception of value for N and minimum bending radius;
tape type II, embossed carrier tape with top cover tape on the upper side;

max. pieces of filters per reel: 3400

Tape (all dimensions in mm)

W	: 16 ± 0,3
Po	: 4 ± 0,1
Do	: 1,5 + 0,5
D1	: 1,5 + 0,5
E	: 1,75 ± 0,1
F	: 7,5 ± 0,1
G (min)	: 0,75
P2	: 2 ± 0,05
P1	: 8 ± 0,1
D1(min)	: 1,5
Ao	: 5,3 ± 0,1
Bo	: 9,7 ± 0,1

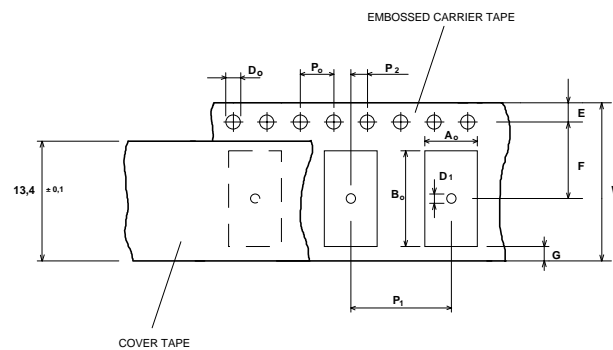
**Reel (all dimensions in mm):**

A	:	330
W1	:	16,4 +2
W2 (max)	:	22,4
N (min)	:	>= 90
C	:	13 ± 0,25

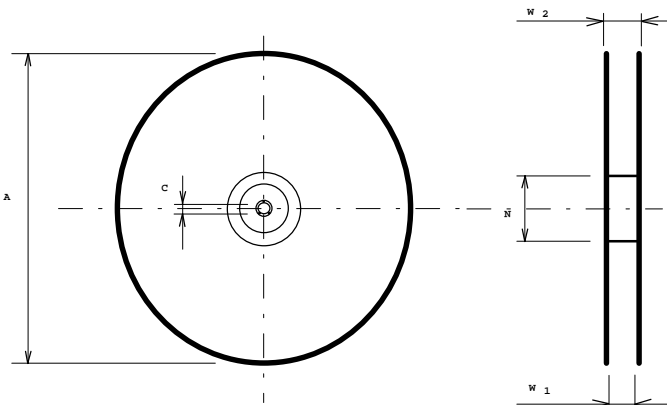

The minimum bending radius is 45 mm. The mounting surface of the filters faces the bottom side of the embossed carrier tape. The marking of the filters is able to read if the view is directed on the upper side of the carrier tape with the sprocket holes on the right side of the tape.

VI TELEFILTER

Potsdamer Straße 18

D 14 513 TELTOW / Germany

Tel: (+49) 3328 4784-52 / Fax: (+49) 3328 4784-30

E-Mail: tft@telefilter.com

Vectron International, Inc.

267 Lowell Road

Hudson, NH 03051 / USA

Tel: (603) 598-0070 Fax: (603) 598-0075

E-Mail: vti@vtinh.com

Air Reflow Temperature Conditions

1st and 2nd air reflow profile

Name:	pre-heating periods	main-heating periods	peak temperature
Temperature:	150 °C - 170 °C	over 200 °C	255 °C ± 5 °C
Time:	60 sec. - 90 sec.	20 sec. - 25 sec.	

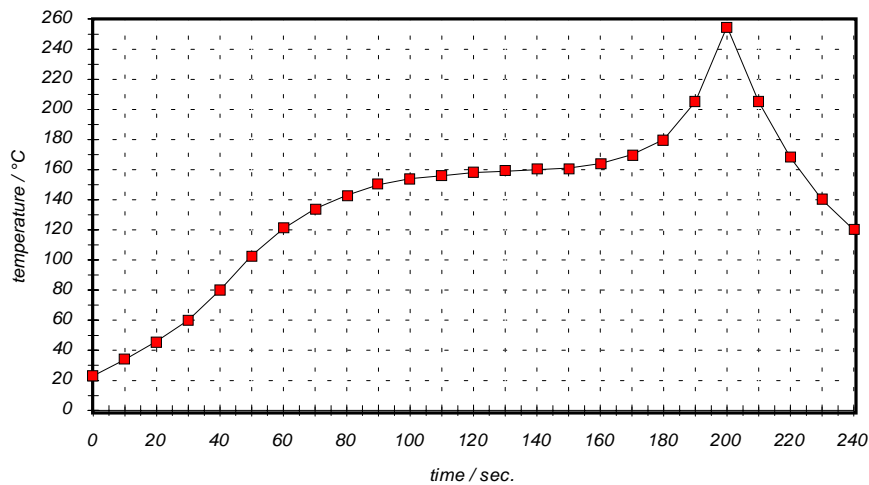
Chip-mount air reflow profile

Table for temperature vs. time during the air reflow process

Tolerance of temperatures: ± 5 °C

time / sec.	temperature / °C	time / sec.	temperature / °C
0	23	140	160
10	34	150	161
20	46	160	164
30	60	170	170
40	80	180	180
50	103	190	205
60	121	195	230
70	134	200	255
80	143	205	230
90	150	210	205
100	154	215	180
110	156	220	165
120	158	230	140
130	159	240	120