

TC74HC173AP, TC74HC173AF

QUAD D - TYPE REGISTER (3 - STATE)

The TC74HC173A is a high speed CMOS D - TYPE REGISTER fabricated with silicon gate C²MOS technology. It achieves the high speed operation similar to equivalent LSTTL while maintaining the CMOS low power dissipation. It consists a 4 - bit register consisting of D - type flip - flops and 3 - state buffers. The four flip - flops are controlled by a common clock input (CK) and a common clear input (CLR). Signals applied to the data inputs (D1~D4) are stored in the respective flip - flops on the positive going transition of CK when clock control inputs (G1, G2) are held low. The clear function is asynchronous to CK and active on a high level. The stored data are enabled to each outputs when output control inputs (M, N) are held low, else the outputs are high impedance state. All inputs are equipped with protection circuits against static discharge or transient excess voltage.

FEATURES :

- High Speed..... $f_{MAX} = 47\text{MHz}(\text{typ.})$ at $V_{CC} = 5\text{V}$
- Low Power Dissipation..... $I_{CC} = 4\mu\text{A}(\text{Max.})$ at $T_a = 25^\circ\text{C}$
- High Noise Immunity..... $V_{NIH} = V_{NIL} = 28\% V_{CC} (\text{Min.})$
- Output Drive Immunity..... 15 LSTTL Loads
- Symmetrical Output Impedance... $|I_{OH}| = I_{OL} = 6\text{mA}(\text{Min.})$
- Balanced Propagation Delays..... $t_{pLH} \approx t_{pHL}$
- Wide Operating Voltage Range... $V_{CC} (\text{opr.}) = 2\text{V} \sim 6\text{V}$
- Pin and Function Compatible with 74LS173

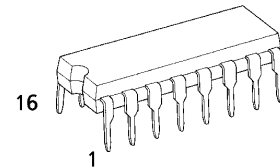

P (DIP16-P-300-2.54A)
Weight : 1.00g (Typ.)

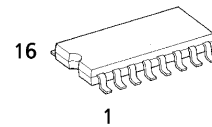

F (SOP16-P-300-1.27)
Weight : 0.18g (Typ.)

PIN ASSIGNMENT

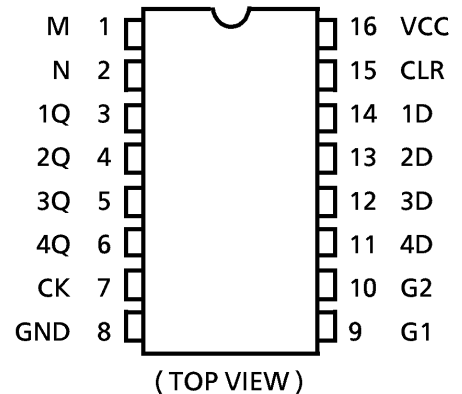

IEC LOGIC SYMBOL

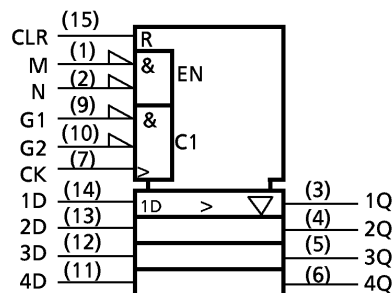

TRUTH TABLE

CLR	CK	DATA INABLE		Dn	OUTPUT CONTROL		Qn
		G1	G2		M	N	
X	X	X	X	X	H	X	Z
X	X	X	X	X	X	H	Z
H	X	X	X	X	L	L	L
L	\downarrow	X	X	X	L	L	Q0
L	\uparrow	H	X	X	L	L	Q0
L	\uparrow	X	H	X	L	L	Q0
L	\uparrow	L	L	H	L	L	H
L	\uparrow	L	L	L	L	L	L

H : Don't Care

Z : High Impedance

SYSTEM DIAGRAM

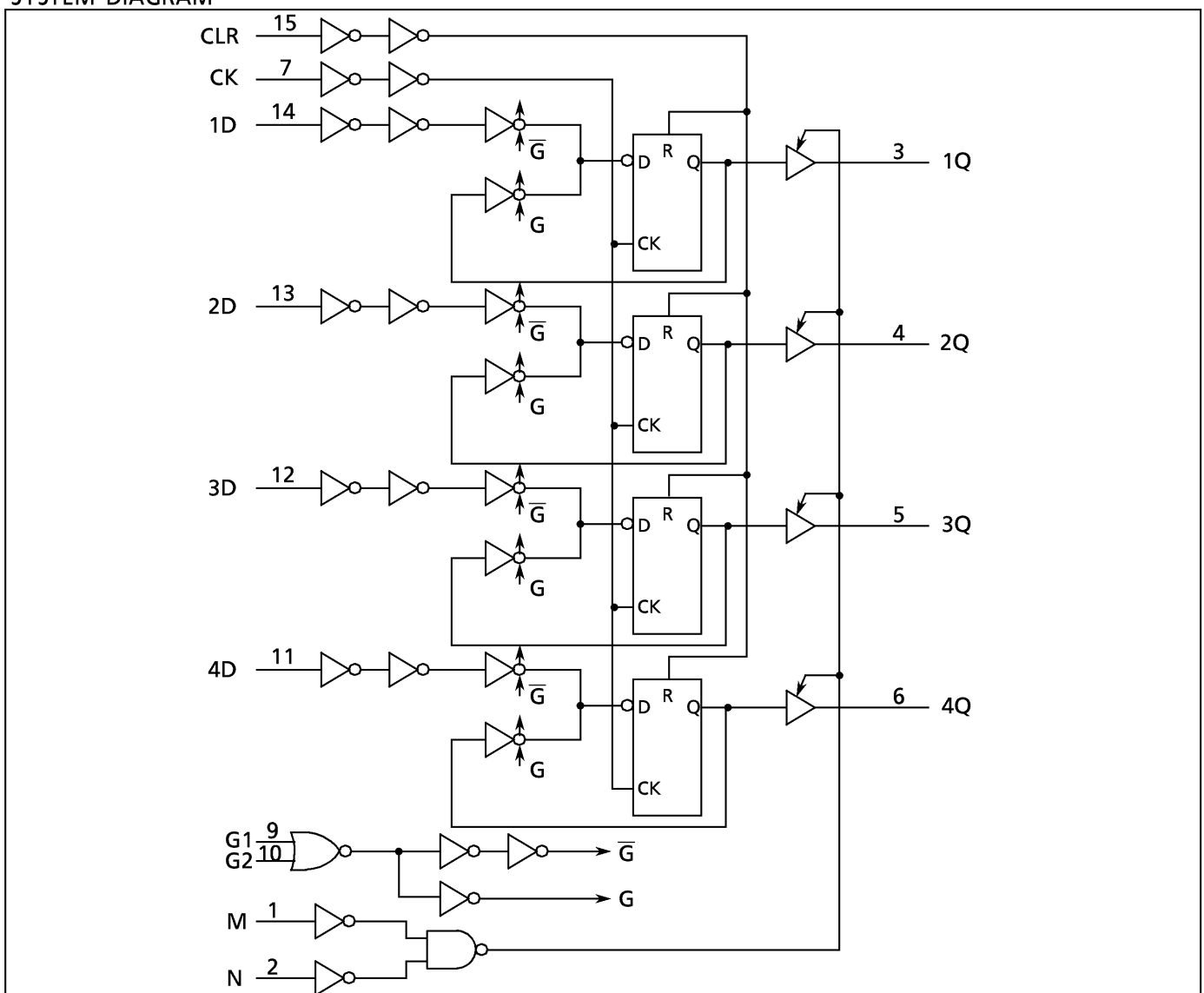

ABSOLUTE MAXIMUM RATINGS

PARAMETER	SYMBOL	VALUE	UNIT
Supply Voltage Range	V _{CC}	-0.5~7	V
DC Input Voltage	V _{IN}	-0.5~V _{CC} +0.5	V
DC Output Voltage	V _{OUT}	-0.5~V _{CC} +0.5	V
Input Diode Current	I _{IK}	±20	mA
Output Diode Current	I _{OK}	±20	mA
DC Output Current	I _{OUT}	±35	mA
DC V _{CC} / Ground Current	I _{CC}	±75	mA
Power Dissipation	P _D	500 (DIP)* / 180 (SOP)	mW
Storage Temperature	T _{stg}	-65~150	°C

*500mW in the range of Ta = -40°C~65°C. From Ta = 65°C to 85°C a derating factor of -10mW/°C shall be applied until 300mW.

RECOMMENDED OPERATING CONDITIONS

PARAMETER	SYMBOL	VALUE	UNIT
Supply Voltage	V _{CC}	2~6	V
Input Voltage	V _{IN}	0~V _{CC}	V
Output Voltage	V _{OUT}	0~V _{CC}	V
Operating Temperature	T _{opr}	-40~85	°C
Input Rise and Fall Time	t _r , t _f	0~1000 (V _{CC} = 2.0V) 0~500 (V _{CC} = 4.5V) 0~400 (V _{CC} = 6.0V)	ns

DC ELECTRICAL CHARACTERISTICS

PARAMETER	SYMBOL	TEST CONDITION	V _{CC} (V)	Ta = 25°C			Ta = -40~85°C		UNIT	
				MIN.	TYP.	MAX.	MIN.	MAX.		
High - Level Input Voltage	V _{IH}		2.0	1.50	—	—	1.50	—	V	
			4.5	3.15	—	—	3.15	—		
			6.0	4.20	—	—	4.20	—		
Low - Level Input Voltage	V _{IL}		2.0	—	—	0.50	—	0.50	V	
			4.5	—	—	1.35	—	1.35		
			6.0	—	—	1.80	—	1.80		
High - Level Output Voltage	V _{OH}	V _{IN} = V _{IH} or V _{IL}	I _{OH} = -20μA	2.0	1.9	2.0	—	1.9	V	
				4.5	4.4	4.5	—	4.4		
			I _{OH} = -6 mA I _{OH} = -7.8 mA	6.0	5.9	6.0	—	5.9		
				4.5	4.18	4.31	—	4.13		
Low - Level Output Voltage	V _{OL}	V _{IN} = V _{IH} or V _{IL}	I _{OL} = 20μA	2.0	—	0.0	0.1	—	0.1	V
				4.5	—	0.0	0.1	—	0.1	
			I _{OL} = 6 mA I _{OL} = 7.8 mA	6.0	—	0.0	0.1	—	0.1	
				4.5	—	0.17	0.26	—	0.33	
6.0	—	0.18	0.26	—	0.33					
3 - State Output Off - State Current	I _{OZ}	V _{IN} = V _{IH} or V _{IL} V _{OUT} = V _{CC} or GND	6.0	—	—	±0.5	—	±5.0	μA	
Input Leakage Current	I _{IN}	V _{IN} = V _{CC} or GND	6.0	—	—	±0.1	—	±1.0		
Quiescent Supply Current	I _{CC}	V _{IN} = V _{CC} or GND	6.0	—	—	4.0	—	40.0		

TIMING REQUIREMENTS (Input $t_r = t_f = 6\text{ns}$)

PARAMETER	SYMBOL	TEST CONDITION	Ta = 25°C			Ta = -40~85°C	UNIT
			V _{CC} (V)	TYP.	LIMIT	LIMIT	
Minimum Pulse Width (CK)	$t_{W(L)}$ $t_{W(H)}$		2.0	—	75	95	ns
			4.5	—	15	19	
			6.0	—	13	16	
Minimum Pulse Width (CLR)	$t_{W(H)}$		2.0	—	75	95	
			4.5	—	15	19	
			6.0	—	13	16	
Minimum Set-up Time (G1, G2)	t_s		2.0	—	100	125	
			4.5	—	20	25	
			6.0	—	17	21	
Minimum Set-up Time (D)	t_s		2.0	—	75	95	
			4.5	—	15	19	
			6.0	—	13	16	
Minimum Hold Time (G1, G2, D)	t_h		2.0	—	0	0	
			4.5	—	0	0	
			6.0	—	0	0	
Minimum Removal Time (CLR)	t_{rem}		2.0	—	5	5	
			4.5	—	5	5	
			6.0	—	5	5	
Clock Frequency	f		2.0	—	9	7	
			4.5	—	43	34	
			6.0	—	51	40	

AC ELECTRICAL CHARACTERISTICS (Input $t_r = t_f = 6\text{ns}$)

PARAMETER	SYMBOL	TEST CONDITION	CL (pF)	V _{CC} (V)	Ta = 25°C			Ta = -40~85°C		UNIT		
					MIN.	TYP.	MAX.	MIN.	MAX.			
Output Transition Time	t_{TLH} t_{THL}		50	2.0	—	20	60	—	75	ns		
				4.5	—	6	12	—	15			
				6.0	—	5	10	—	13			
Propagation Delay Time (CK—Q)	t_{pLH} t_{pHL}		50	2.0	—	50	115	—	145			
				4.5	—	15	23	—	29			
				6.0	—	12	20	—	25			
			150	2.0	—	65	155	—	195			
				4.5	—	20	31	—	39			
				6.0	—	16	26	—	33			
Propagation Delay Time (CLR—Q)	t_{pHL}		50	2.0	—	50	115	—	145			
				4.5	—	15	23	—	29			
				6.0	—	12	20	—	25			
			150	2.0	—	63	155	—	195			
				4.5	—	20	31	—	39			
				6.0	—	16	26	—	33			
Output Enable time	t_{pZL} t_{pZH}	$R_L = 1\text{k}\Omega$	50	2.0	—	50	115	—	145			
				4.5	—	15	23	—	29			
				6.0	—	12	20	—	25			
			150	2.0	—	63	115	—	195			
				4.5	—	20	31	—	39			
				6.0	—	16	26	—	33			
Output Disable time	t_{pLZ} t_{pHZ}	$R_L = 1\text{k}\Omega$	50	2.0	—	36	135	—	170			
				4.5	—	17	27	—	34			
				6.0	—	15	23	—	29			
			Maximum Clock Frequency	f_{MAX}		50	2.0	9	20	—	7	MHz
							4.5	43	67	—	34	
							6.0	51	84	—	40	
Input Capacitance	C_{IN}				—	5	10	—	pF			
Output Capacitance	C_{OUT}				—	10	—	—				
Power Dissipation Capacitance	$C_{PD} (1)$				—	45	—	—				

Note(1) C_{PD} is defined as the value of the internal equivalent capacitance which is calculated from the operating current consumption without load.

Average operating current can be obtained by the equation :

$$I_{CC}(\text{opr}) = C_{PD} \cdot V_{CC} \cdot f_{IN} + I_{CC}/4 \text{ (per Flip Flop)}$$

And the total C_{PD} when n pcs of Flip Flop operate be gained by the following equation :

$$C_{PD}(\text{total}) = 28 + 17 \cdot n$$

DIP 16PIN PACKAGE DIMENSIONS (DIP16-P-300-2.54A)

Unit in mm

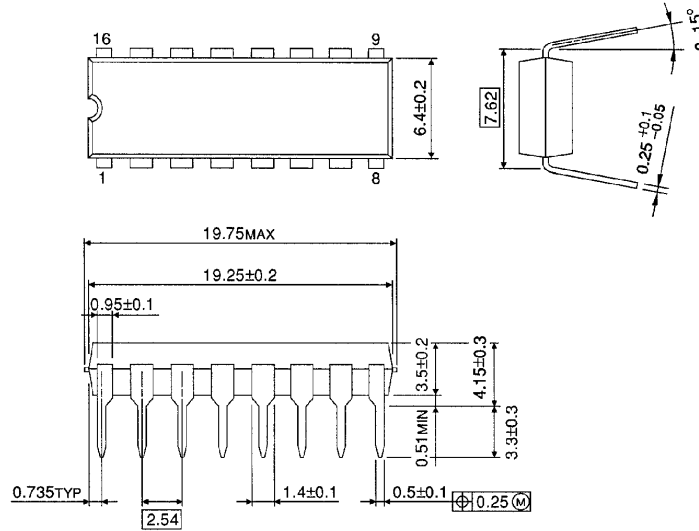

Weight : 1.00g (Typ.)

SOP 16PIN (200mil BODY) PACKAGE DIMENSIONS (SOP16-P-300-1.27)

Unit in mm

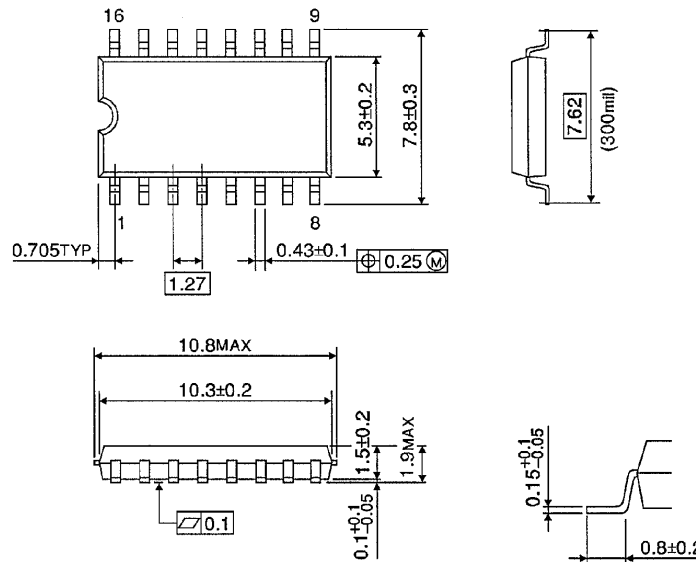

Weight : 0.18g (Typ.)

RESTRICTIONS ON PRODUCT USE

000707EBA

- TOSHIBA is continually working to improve the quality and reliability of its products. Nevertheless, semiconductor devices in general can malfunction or fail due to their inherent electrical sensitivity and vulnerability to physical stress. It is the responsibility of the buyer, when utilizing TOSHIBA products, to comply with the standards of safety in making a safe design for the entire system, and to avoid situations in which a malfunction or failure of such TOSHIBA products could cause loss of human life, bodily injury or damage to property. In developing your designs, please ensure that TOSHIBA products are used within specified operating ranges as set forth in the most recent TOSHIBA products specifications. Also, please keep in mind the precautions and conditions set forth in the "Handling Guide for Semiconductor Devices," or "TOSHIBA Semiconductor Reliability Handbook" etc..
- The TOSHIBA products listed in this document are intended for usage in general electronics applications (computer, personal equipment, office equipment, measuring equipment, industrial robotics, domestic appliances, etc.). These TOSHIBA products are neither intended nor warranted for usage in equipment that requires extraordinarily high quality and/or reliability or a malfunction or failure of which may cause loss of human life or bodily injury ("Unintended Usage"). Unintended Usage include atomic energy control instruments, airplane or spaceship instruments, transportation instruments, traffic signal instruments, combustion control instruments, medical instruments, all types of safety devices, etc.. Unintended Usage of TOSHIBA products listed in this document shall be made at the customer's own risk.
- The products described in this document are subject to the foreign exchange and foreign trade laws.
- The information contained herein is presented only as a guide for the applications of our products. No responsibility is assumed by TOSHIBA CORPORATION for any infringements of intellectual property or other rights of the third parties which may result from its use. No license is granted by implication or otherwise under any intellectual property or other rights of TOSHIBA CORPORATION or others.
- The information contained herein is subject to change without notice.