

Preliminary

TOSHIBA Multi Chip Module

TB7001FL

For high current and low voltage applications
Synchronous buck converter module

This product is a synchronous buck switching converter module. The additional components for DC-DC converter are a PWM control IC, an external inductor, and input and output capacitors.

Features

- 3 chips (high-side MOSFET, low-side MOSFET, MOSFET gate driver- IC) are in 1 package.
- Maximum Input voltage is 19V, it is capable for note-PC applications.
- Under voltage lockout and thermal shut down
- Keeping off low-side MOSFET function. When load current is low, low-side MOSFET is able to be kept off. Consequently the efficiency increases at low load condition.
- Internal control circuit disable function. The quiescent current is less than 10 μ A.
- High operation frequency : $f_c = 1\text{MHz}$ (Max.)
- High output current : $I_{OUT} = 20\text{A}$ (Max.)
- High efficiency : $\eta = 85\%$ (@ $V_{IN} = 12\text{V}$, $V_{OUT} = 1.5\text{V}$, $I_{OUT} = 20\text{A}$, $f_c = 1\text{MHz}$)

Maximum ratings (Ta = 25°C)

Characteristics	Symbol	Ratings	Unit
V_{IN} to PGND voltage	V_{IN}	30	V
L_X to PGND voltage	V_{LX}	-2 ~ 30	V
V_{DD} to SGND voltage	V_{DD}	-0.3 ~ 6	V
BST to L_X voltage	V_{BST-LX}	-0.3 ~ $V_{DD} + 0.3$	V
BST to SGND voltage	V_{BST}	-0.3 ~ 30	V
ON/OFF to SGND voltage	$V_{ON/OFF}$	-0.3 ~ $V_{DD} + 0.3$	V
SD to SGND voltage	V_{SD}	-0.3 ~ $V_{DD} + 0.3$	V
DISBL to SGND voltage	V_{DISBL}	-0.3 ~ $V_{DD} + 0.3$	V
Output RMS current	I_{OUT}	20	A
Power dissipation	P_D	TBD	W
Operating channel temperature	T_{ch-opr}	-40 ~ 150	°C
Storage temperature	T_{stg}	-55 ~ 150	°C

Terminal configurations

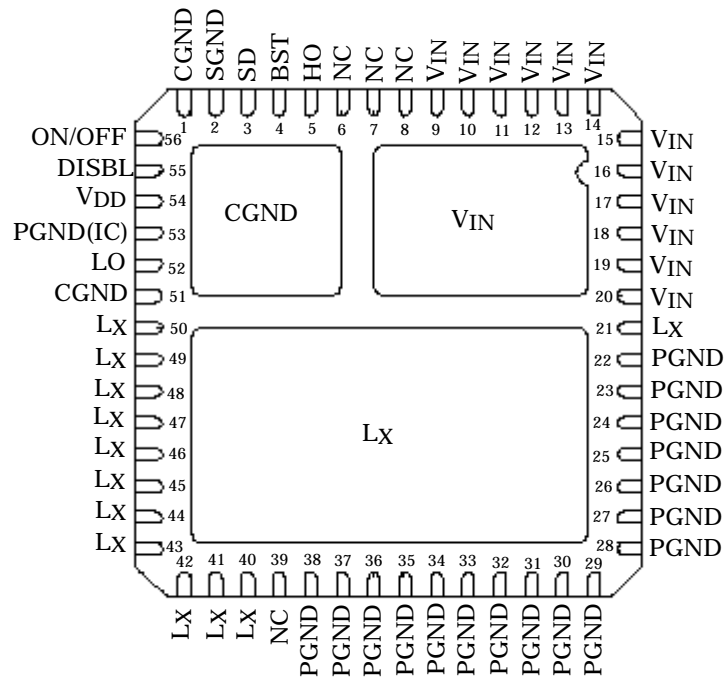

Bottom view

Terminal functions

Name	No.	Functions	Notes
CGND	1,51,Tab	Internal driver-IC chip bed	Connect to the SGND
SGND	2	Internal driver-IC signal ground	Connect to the PGND
SD	3	Shut down signal for the low-side MOSFET. When set to low, the low-side MOSFET is turned off.	
BST	4	Connect to the external boot strap capacitor	
HO	5	High-side MOSFET gate signal	For monitoring
NC	6,7,8,39	No internal connection. Keep them open.	
V _{IN}	9 ~ 20,Tab	Input voltage for the DC-DC converter	
L _X	21,40 ~ 50,Tab	Switching node. Connect to the output inductor.	
PGND	22 ~ 38	Power ground	
LO	52	Low-side MOSFT gate signal	For monitoring
PGND(IC)	53	Internal driver-IC power ground	
V _{DD}	54	Supply voltage for the internal driver-IC	
DISBL	55	Disable signal for the internal control circuit. When set to low, the Internal control circuit is disabled. The high-side MOSFET and low-side MOSFET are turned off.	
ON/OFF	56	Input signal	

Recommended PCB footprint

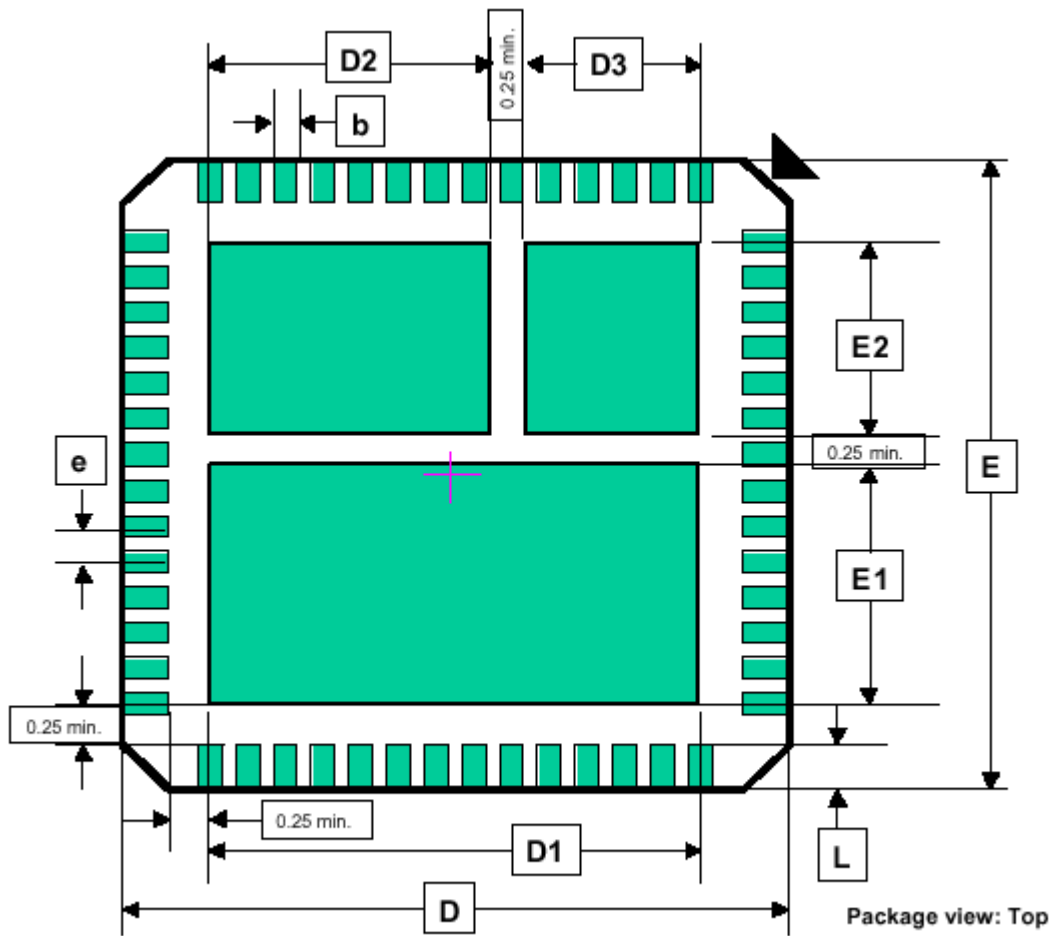

S Y M	DIMENSION			N o T e
	Min	Nom	Max	
e	0.5 BSC			
L	0.30	0.40	0.50	
b	0.18	0.23	0.30	
D	8.0			
D1	6.20	6.35	6.50	
D2	3.55	3.65	3.80	
D3	2.10	2.30	2.45	
E	8.0			
E1	3.55	3.65	3.80	
E2	2.10	2.30	2.45	

(unit : mm)

Timing chart

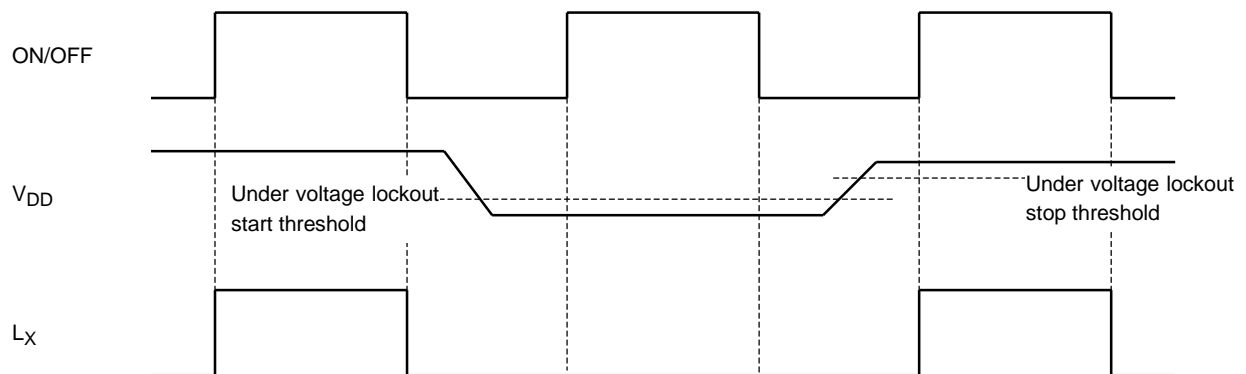

Under voltage lockout : When V_{DD} is lower than Under voltage lockout start threshold, the operation is stopped.

When V_{DD} is higher than Under voltage lockout stop threshold, it return to the normal operation.

(The hysteresis between lockout start and lockout stop is 0.7V.)

Electrical specifications ($V_{DD}=5V$, $T_a=25$, unless otherwise noted.)

Characteristics	Symbol	Terminal	Conditions	Min.	Typ.	Max.	Unit	
Operating input Voltage (V_{IN})	$V_{IN(OPR)}$	V_{IN}	-	7	-	19	V	
Operating input Voltage (V_{DD})	$V_{DD(OPR)}$	V_{DD}	-	4.5	5	5.5	V	
V_{DD} quiescent current	$I_{DD(OFF)}$	V_{DD}	$V_{DISBL} = 0$	-	-	15	μA	
ON/OFF input current H	$I_{INH(ON/OFF)}$	ON/OFF	$V_{ON/OFF} = 5V$	-	0.25	0.4	mA	
ON/OFF input current L	$I_{INL(ON/OFF)}$	ON/OFF	$V_{ON/OFF} = 0$	-	0	-	mA	
SD input current H	$I_{INH(SD)}$	SD	$V_{SD} = 5V$	-	0	-	mA	
SD input current L	$I_{INL(SD)}$	SD	$V_{SD} = 0$	-0.4	-0.25	-	mA	
ON/OFF input rising threshold	$V_{H(ON/OFF)}$	ON/OFF	-	2.0	-	-	V	
ON/OFF input falling threshold	$V_{L(ON/OFF)}$	ON/OFF	-	-	-	0.8	V	
SD input rising threshold	$V_{H(SD)}$	SD	-	2.0	-	-	V	
SD input falling threshold	$V_{L(SD)}$	SD	-	-	-	0.8	V	
DISBL input rising threshold	$V_{H(DISBL)}$	DISBL	-	2.0	-	-	V	
DISBL input falling threshold	$V_{L(DISBL)}$	DISBL	-	-	-	0.8	V	
Output ON resistance	$R_{DS(ON)(L)}$	L_X -PGND	$I_{LX} = 10A$	-	5	-	m	
	$R_{DS(ON)(H)}$	V_{IN} - L_X	$I_{LX} = -10A$, $V_{BST-LX} = 5V$	-	10	-	m	
Output cut-OFF current	$I_{LEAK(H)}$	V_{IN} - L_X	$V_{IN} = 24V$, $L_X = 0$	-	-	10	μA	
	$I_{LEAK(L)}$	L_X -PGND	$V_{LX} = 24V$, $PGND = 0$	-	-	100	μA	
Switching time	Turn off	t_{off}	L_X	$V_{BST-LX} = 5V$ $I_{LX} = -20A$	-	30	-	ns
	Turn on	t_{on}	L_X		-	60	-	ns
Internal SBD foreword voltage	V_F	PGND- L_X	$I_{DR} = 10A$	-	0.6	0.7	V	
Under voltage lock out start threshold	V_{UVLO}	V_{DD}	-	2.6	2.8	3.1	V	
Under voltage lock out hysteresis	$V_{hys-UVLO}$	V_{DD}	-	-	0.7	-	V	

