

TOSHIBA Bipolar Linear Integrated Circuit Silicon Monolithic

TA2028F, TA2028P

Filter IC For Σ - Δ Modulation System DA Converter

TA2028F, TA2028P are an analog filter IC for Σ - Δ modulation system DA converter.

Using the TA2028F, TA2028P in combination the TC9237BF, TC9237BN (the Σ - Δ modulation system DA converter with a built-in digital filter), it is possible to construct a DA conversion system with less external parts.

Features

- Built-in CR for LPFs and output (differential) amplifiers for the left and right channel.
- Single power supply operation.
(+9V operation: BS tuner system)
- Noise distortion factor and S / N ratio are as follows
(when operating at +5V single power supply):
Noise distortion factor: -86dB (typ.)
S / N: 100dB (typ.)

Pin Connection (top view)

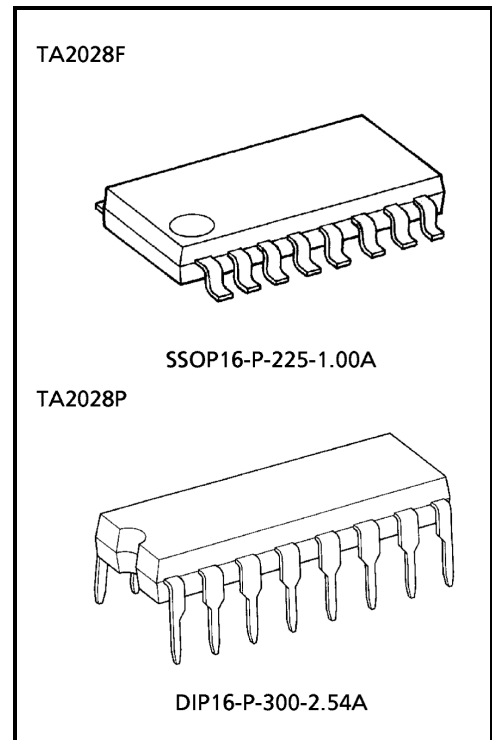
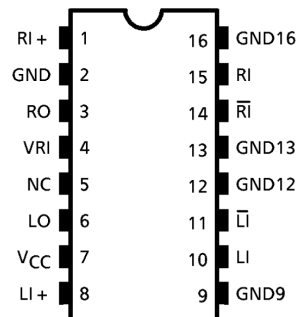

Weight
SSOP16-P-225-1.00A: 0.14g (typ.)
DIP16-P-300-2.54A: 1.00g (typ.)

Block Diagram

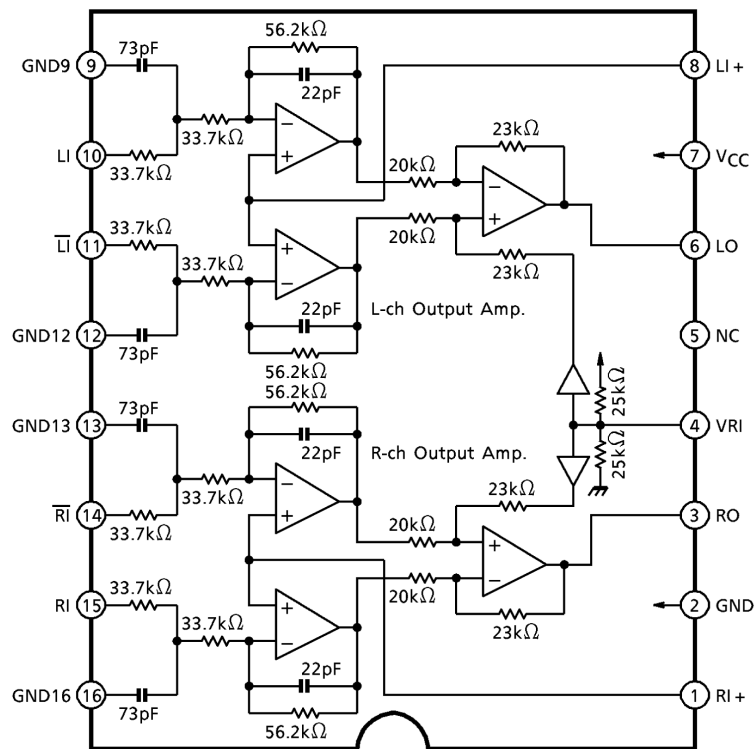

Description Of Pin Functions

Pin No.	Symbol	I / O	Function & Operation	Remarks
1	RI +	I	R channel operational amplifier forward input pin. Connect to VRI.	—
2	GND	—	Ground pin.	—
3	RO	O	R channel analog output pin.	—
4	VRI	—	Reference voltage pin. ($V_{CC} / 2$)	See the block diagram
5	NC	—	Non-connecting pin. NC pin is used in the open state.	—
6	LO	O	L channel analog output pin.	—
7	V _{CC}	—	Supply voltage pin.	—
8	LI +	I	L channel operational amplifier forward input pin. Connect to VRI.	—
9	GND9	—	Ground pin for L channel reverse input side filter.	—
10	LI	I	L channel forward input pin.	Connect to LO of TC9237BF, TC9237BN
11	LI-bar	I	L channel reverse input pin.	Connect to LO-bar of TC9237BF, TC9237BN
12	GND12	—	Ground pin for L channel forward input side filter.	—
13	GND13	—	Ground pin for R channel forward input side filter.	—
14	RI-bar	I	R channel reverse input pin.	Connect to RO-bar of TC9237BF, TC9237BN
15	RI	I	R channel forward input pin.	Connect to RO of TC9237BF, TC9237BN
16	GND16	—	Ground pin for R channel reverse input side filter.	—

Maximum Ratings (Ta = 25°C)

Characteristic	Symbol	Rating	Unit
Supply voltage	V _{CC}	11	V
Power dissipation	TA2028F	P _D	mW
	TA2028P		
Operating temperature	T _{opr}	-25~75	°C
Storage temperature	T _{stg}	-55~150	°C

(*) Reduce 2.8mW / °C at Ta = above 25°C.

(**) Reduce 11.2mW / °C at Ta = above 25°C.

Electrical Characteristics (unless otherwise specified, V_{CC} = 5V, Ta = 25°C)

Characteristic	Symbol	Test Circuit	Test Condition	Min.	Typ.	Max.	Unit
Operating supply voltage	V _{CC}	—	Ta = -35~85°C	8.0	9.0	10	V
Operating supply current	I _{CCQ}	—	At no signal	8.1	11.0	13.7	mA
Reference voltage	V _{RI}	—	—	4.4	4.5	4.6	V
Noise distortion factor	THD (1)	1	1kHz, V _O = 2mV _{rms}	—	-86	-83	dB
	THD (2)		10kHz, V _O = 2mV _{rms}	—	-86	-83	
	THD (3)		1kHz, V _O = 100mV _{rms}	—	-74	-70	
Cross talk	CT	1	1kHz, V _O = 2mV _{rms}	—	-100	-90	dB
Attenuation	ATT (1)	1	40kHz, V _O = -10dBV _{rms}	0.51	0.71	1.41	dB
	ATT (2)		80kHz, V _O = -10dBV _{rms}	1.50	2.70	4.50	
Max. output level	V _{omax}	1	1kHz, THD = 1%	2.5	2.6	—	V _{rms}
Differential balance	G _{VB}	1	1kHz, 1.1dBV _{rms} In-phase input	—	—	-40	dB
LR output difference	G _{VD}	1	1kHz, 1.1dBV _{rms} Differential input	—	0	0.5	dB

(Note 1) When the TC9327BF, TC9237BN (+5V) and +9V single power supply are operated : Full scale = 2mV_{rms} (typ.).

(Note 2) The amount of attenuations is based on 1kHz, V_O = -10dBV_{rms}.

(Note 3) Measuring circuit-1: Indicates the measuring circuit.

Test Circuit-1

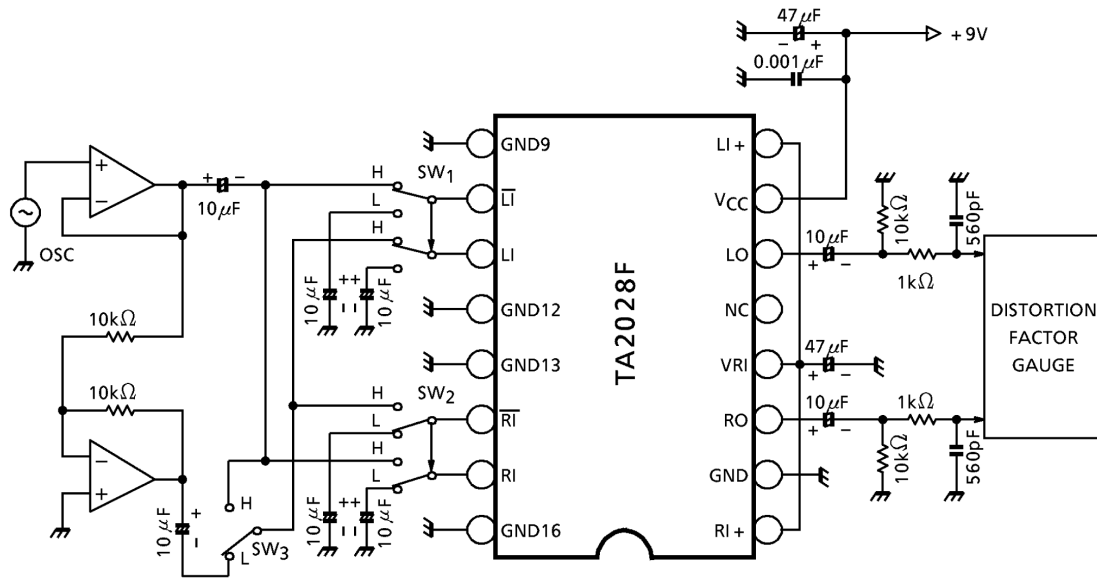

SW ₁	SW ₂	SW ₃	Measuring Item
L	L	—	Operating supply voltage, reference voltage
L	H	L	Cross talk (R→L)
H	L	L	Cross talk (L→R)
H	H	L	Noise distortion factor, attenuation, maximum output level, LR output difference
H	H	H	Difference balance

Application Circuit Example

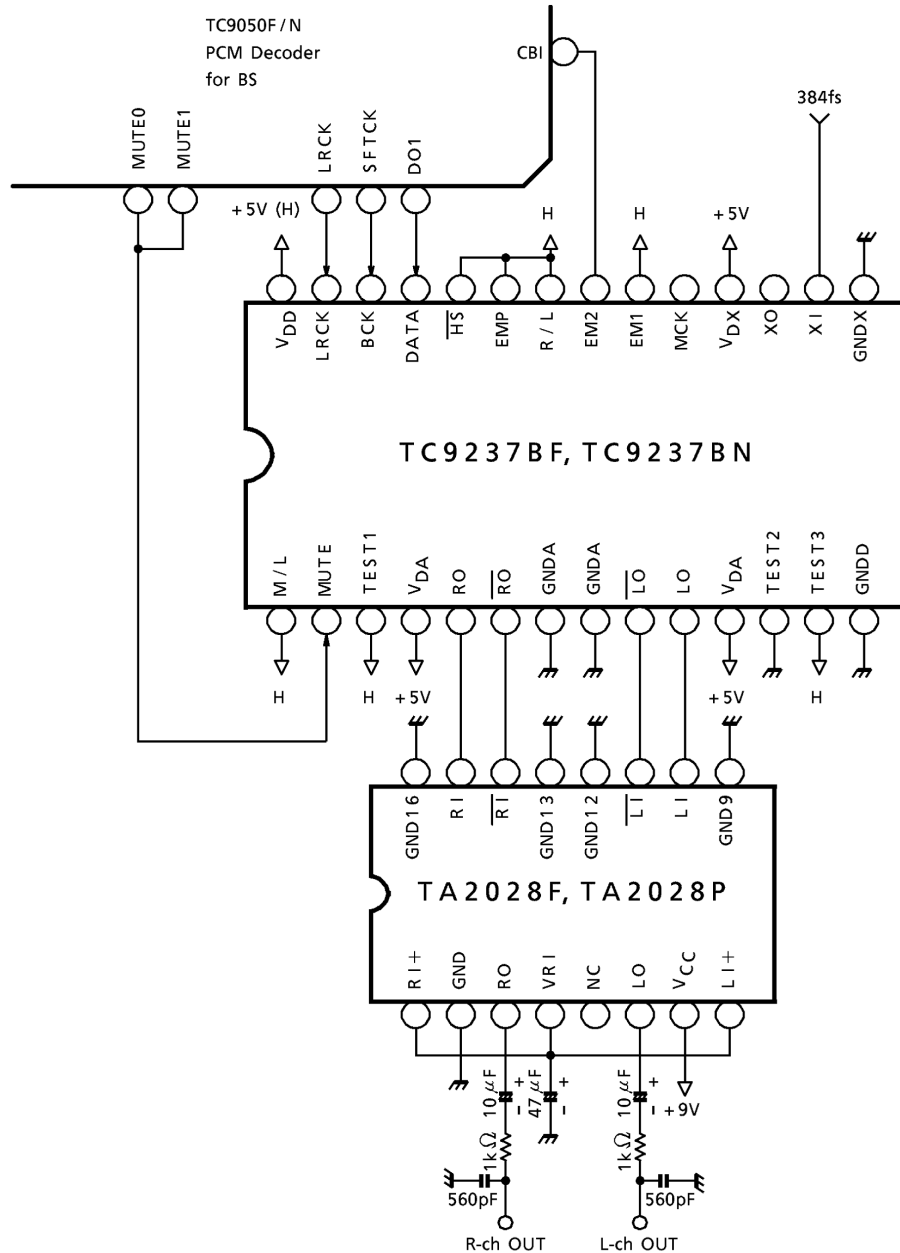

(Cautions)

- Quality of crystal oscillation waveform largely effects S / N ratio.
Further, this is also true when system clock is input externally through the XI pin of pin(16).
- Suppress glitch of input signals (LRCK, BCK, DATA) as could as possible.
- The wiring between the TC9237BF, TC9237BN output and the analog filter amplifier input must be made the shortest
- The capacitor between V_{DA} and GNDA shall be connected as close to the pin as possible.
- NC pin is used in the open state.

Package Dimensions

SSOP16-P-225-1.00A

Unit : mm

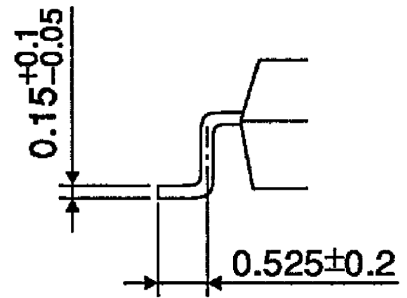
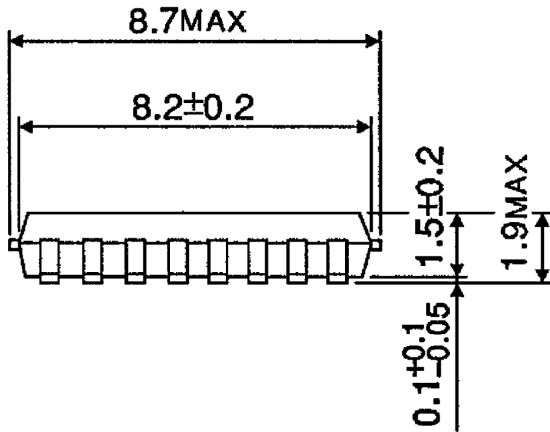
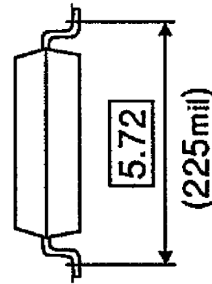
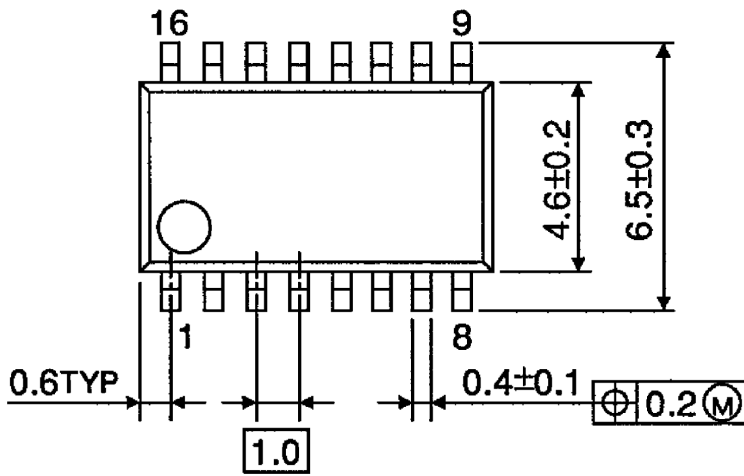

Weight: 0.14g (typ.)

Package Dimensions

DIP16-P-300-2.54A

Unit : mm

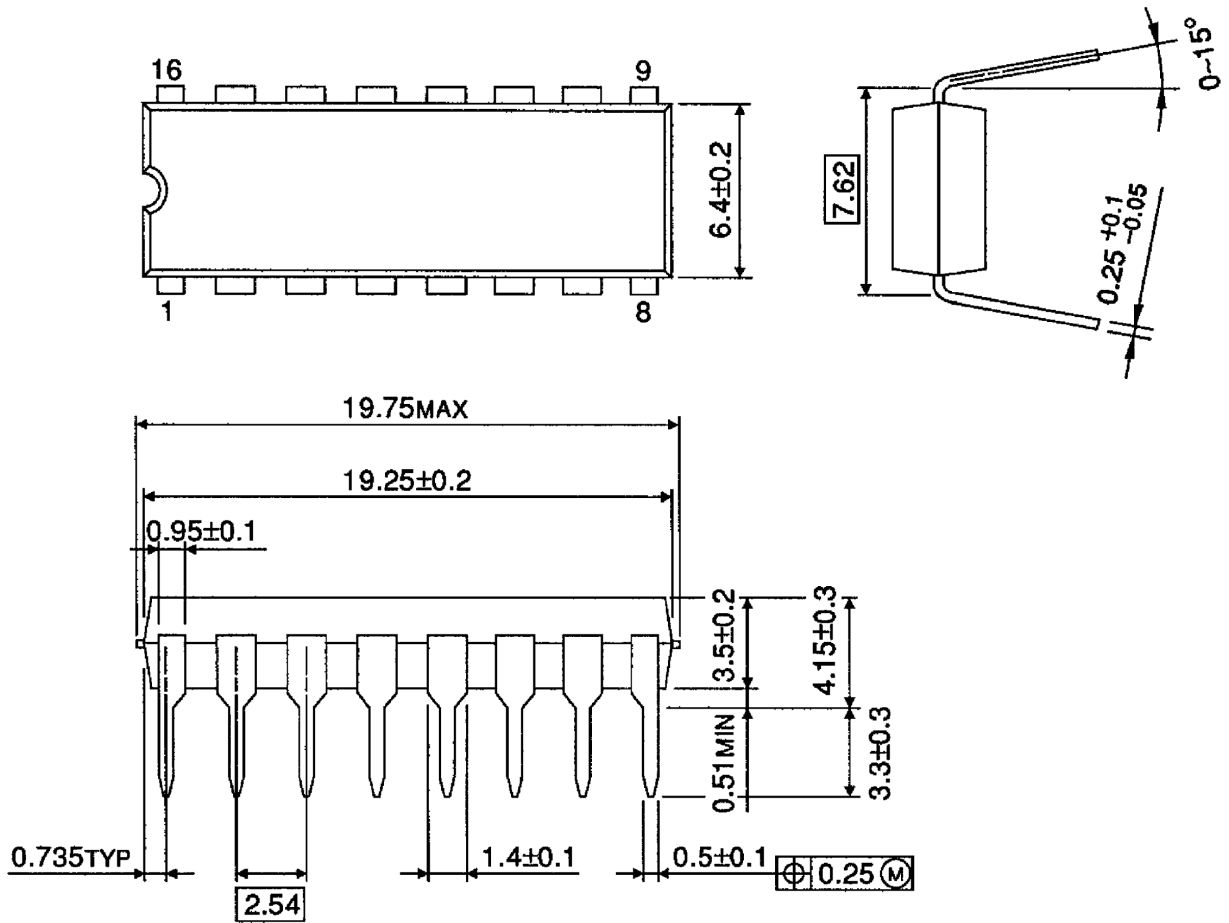

Weight: 1.00g (typ.)

RESTRICTIONS ON PRODUCT USE

000707EBA

- TOSHIBA is continually working to improve the quality and reliability of its products. Nevertheless, semiconductor devices in general can malfunction or fail due to their inherent electrical sensitivity and vulnerability to physical stress. It is the responsibility of the buyer, when utilizing TOSHIBA products, to comply with the standards of safety in making a safe design for the entire system, and to avoid situations in which a malfunction or failure of such TOSHIBA products could cause loss of human life, bodily injury or damage to property.
In developing your designs, please ensure that TOSHIBA products are used within specified operating ranges as set forth in the most recent TOSHIBA products specifications. Also, please keep in mind the precautions and conditions set forth in the "Handling Guide for Semiconductor Devices," or "TOSHIBA Semiconductor Reliability Handbook" etc..
- The TOSHIBA products listed in this document are intended for usage in general electronics applications (computer, personal equipment, office equipment, measuring equipment, industrial robotics, domestic appliances, etc.). These TOSHIBA products are neither intended nor warranted for usage in equipment that requires extraordinarily high quality and/or reliability or a malfunction or failure of which may cause loss of human life or bodily injury ("Unintended Usage"). Unintended Usage include atomic energy control instruments, airplane or spaceship instruments, transportation instruments, traffic signal instruments, combustion control instruments, medical instruments, all types of safety devices, etc.. Unintended Usage of TOSHIBA products listed in this document shall be made at the customer's own risk.
- The products described in this document are subject to the foreign exchange and foreign trade laws.
- The information contained herein is presented only as a guide for the applications of our products. No responsibility is assumed by TOSHIBA CORPORATION for any infringements of intellectual property or other rights of the third parties which may result from its use. No license is granted by implication or otherwise under any intellectual property or other rights of TOSHIBA CORPORATION or others.
- The information contained herein is subject to change without notice.