

ATSM-49 and SX2050 Surface Mount Crystals

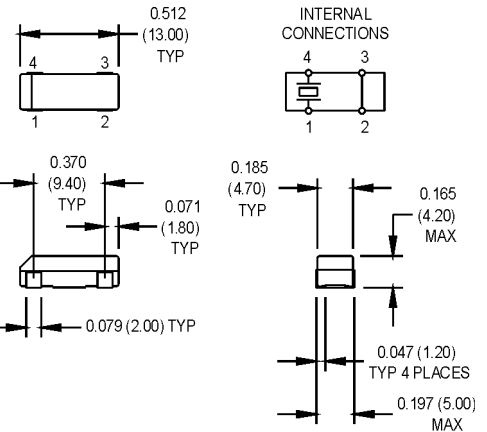

***SX2050-R 00.0000 MHz** (customer specified)
(-R signifies RoHS compliant part)



SUGGESTED SOLDER PAD LAYOUT

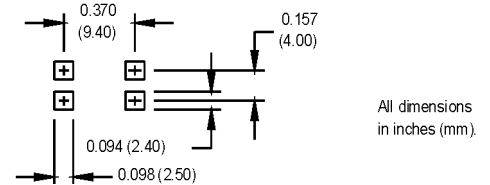

All dimensions in inches (mm).

***ATSM-49-R 00.0000 MHz** (customer specified)
(-R signifies RoHS compliant part)

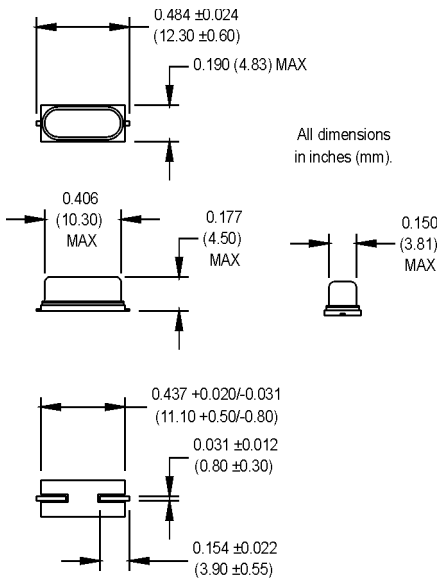

All dimensions in inches (mm).

SUGGESTED SOLDER PAD LAYOUT

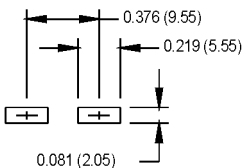

Equivalent Series Resistance (ESR), Max.

Frequency Range	ESR (Ω)
Fundamental (AT-cut)	
3.579 to 3.999 MHz	200 Ω
4.000 to 4.999 MHz	150 Ω
5.000 to 5.999 MHz	120 Ω
6.000 to 9.999 MHz	100 Ω
10.000 to 13.999 MHz	80 Ω
14.000 to 40.000 MHz	50 Ω
Fundamental (BT-cut)	
24.000 to 50.000 MHz	100 Ω
Third Overtones (AT-cut)	
25.000 to 39.999 MHz	100 Ω
40.000 to 72.000 MHz	80 Ω

Electrical Specifications	PARAMETER	Symbol	Min.	Typ.	Max.	Units	Condition/Notes
	Frequency Range	F	3.579545		72	MHz	ATSM-49
			3.579545		60	MHz	SX2050
	Frequency Tolerance	F/F			±30	ppm	ATSM-49
					±50	ppm	SX2050
	Frequency Stability	ΔF/F			±50	ppm	ATSM-49 (See Note 1)
					±100	ppm	SX2050 (See Note 1)
	Operating Temperature	T _A	-10		+70	°C	ATSM-49
			-20		+70	°C	SX2050
	Storage Temperature	T _s	-55		+125	°C	
	Aging						
	1st Year						
	Thereafter (per year)						
	Load Capacitance	C _L		18		pF	See Note 2
	Shunt Capacitance	C ₀			7	pF	ATSM-49
				5	pF	SX2050	
ESR		See ESR Tables					
Drive Level	D _L			500	μW	ATSM-49	
				100	μW	SX2050	
Insulation Resistance	I _r	500			MΩ		

Note 1: BT Cut fundamentals from 24.000 to 40.000 MHz have a stability of ±100 ppm

Note 2: Series resonant designated by "SR" prefix (i.e., SRATSM-49 or SRSX2050)

MtronPTI reserves the right to make changes to the product(s) and service(s) described herein without notice. No liability is assumed as a result of their use or application.

Please see www.mtronpti.com for our complete offering and detailed datasheets. Contact us for your application specific requirements: MtronPTI 1-800-762-8800.

MtronPTI Lead Free Solder Profile

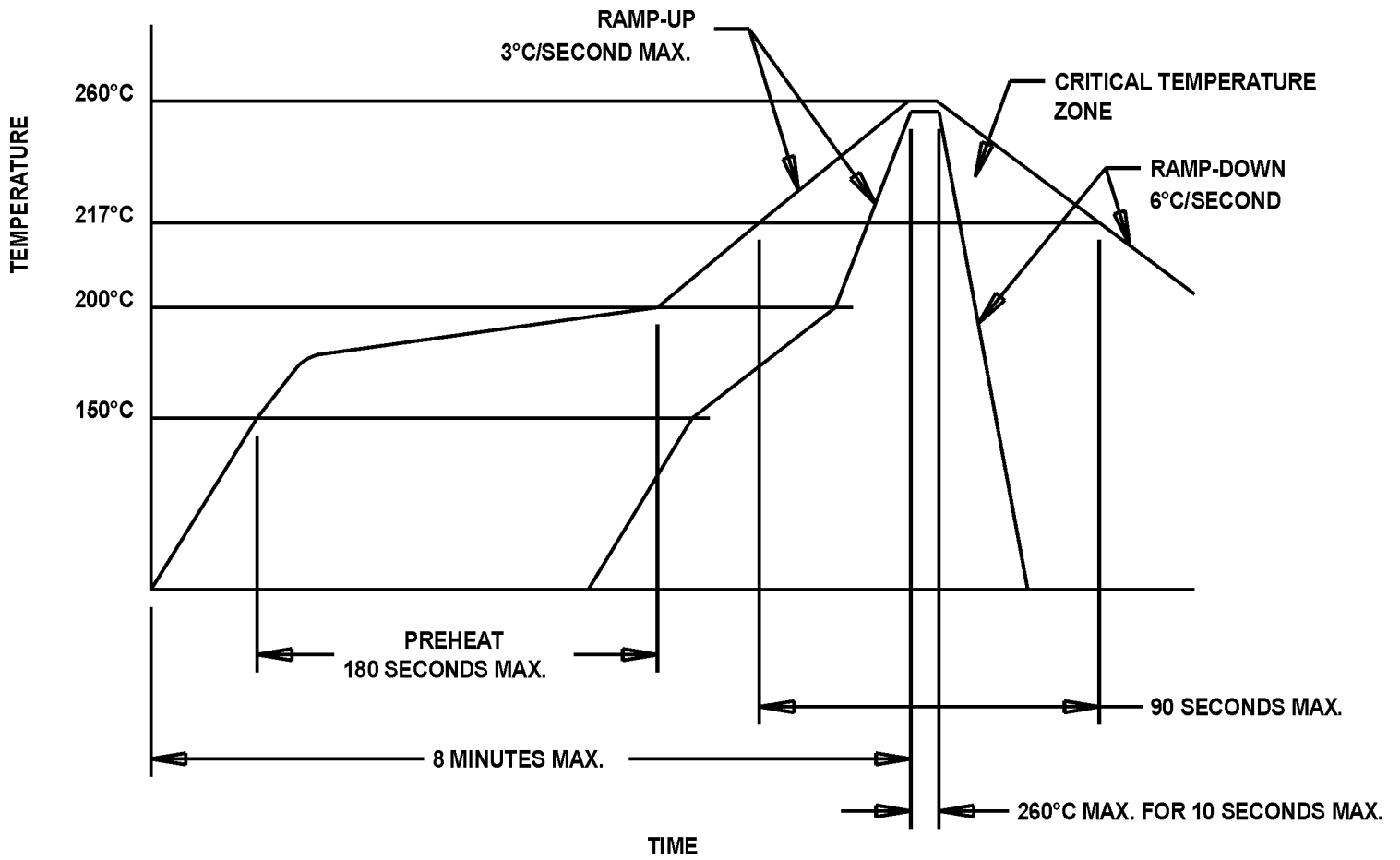

MtronPTI reserves the right to make changes to the product(s) and service(s) described herein without notice. No liability is assumed as a result of their use or application.

Please see www.mtronpti.com for our complete offering and detailed datasheets. Contact us for your application specific requirements: MtronPTI 1-800-762-8800.