



INTEGRATED POTS INTERFACE FOR HOME ACCESS GATEWAY AND WLL

1 FEATURES

- MONOCHIP SLIC OPTIMISED FOR WLL & VoIP APPLICATIONS
- IMPLEMENT ALL KEY FEATURES OF THE BORSHT FUNCTION
- SINGLE SUPPLY (4.5 TO 12V)
- BUILT IN DC/DC CONVERTER CONTROLLER.
- SOFT BATTERY REVERSAL WITH PROGRAMMABLE TRANSITION TIME.
- ON-HOOK TRANSMISSION.
- PROGRAMMABLE OFF-HOOK DETECTOR THRESHOLD
- METERING PULSE GENERATION AND FILTER
- INTEGRATED RINGING
- INTEGRATED RING TRIP
- PARALLEL CONTROL INTERFACE (3.3V LOGIC LEVEL)
- PROGRAMMABLE CONSTANT CURRENT FEED
- SURFACE MOUNT PACKAGE
- INTEGRATED THERMAL PROTECTION
- DUAL GAIN VALUE OPTION
- AUTOMATIC RECOGNITION FLYBACK AND

Figure 1. Package



Table 1. Order Codes

Part Number	Package
STLC3075	TQFP44

BUCKBOOST CONFIGURATION

- BCDIIS 90V TECHNOLOGY
- -40 TO +85°C OPERATING RANGE

2 DESCRIPTION

The STLC3075 is a SLIC device specifically designed for WLL (Wireless Local Loop), and ISDN-Terminal Adaptors and VoIP applications. One of the distinctive characteristic of this device is the ability to operate with a single supply voltage (from +4.5V to +12V) and self generate the negative battery by means of an on chip DC/DC converter controller that drives an external MOS switch.

Figure 2. Block Diagram

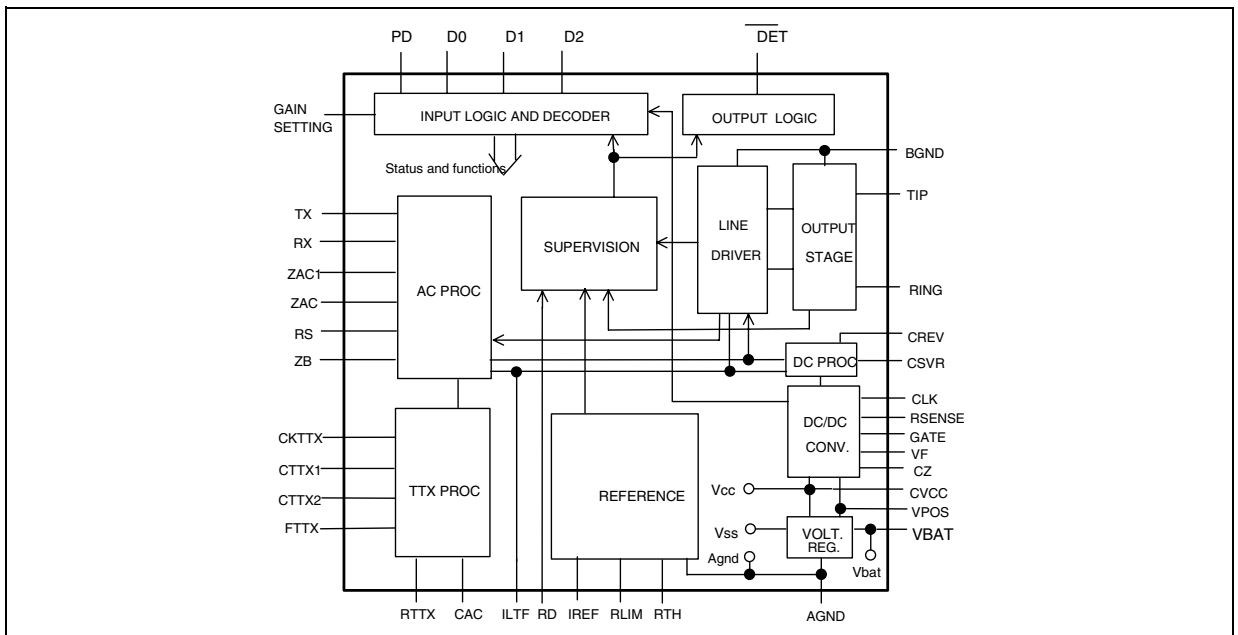

2 DESCRIPTION (continued)

The battery level is properly adjusted depending on the operating mode. A useful characteristic for these applications is the integrated ringing generator.

The control interface is a parallel type with open drain output and 3.3V logic levels.

The metering pulses are generated on chip starting from two logic signals (0, 3.3V) one define the metering pulse frequency and the other the metering pulse duration. An on chip circuit then provides the proper shaping and filtering. Metering pulse amplitude and shaping (rising and decay time) can be programmed by external components.

A dedicated cancellation circuit avoid possible CODEC input saturation due to Metering pulse echo.

Constant current feed can be set from 20mA to 40mA. Off-hook detection threshold is programmable from 5mA to 9mA.

The device, developed in BCDIIS technology (90V process), operates in the extended temperature range and integrates a thermal protection that sets the device in power down when T_j exceeds 140°C.

Figure 3. Pin Connection

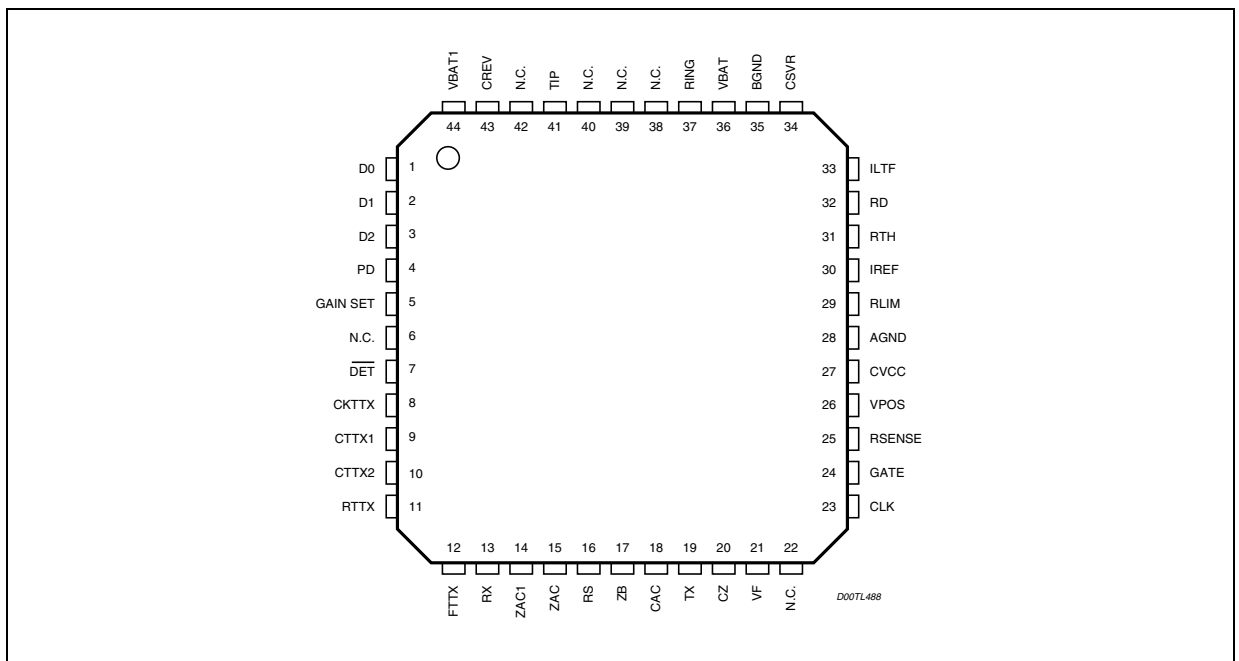

Table 2. Absolute Maximum Ratings

Symbol	Parameter	Value	Unit
V_{pos}	Positive Supply Voltage	-0.4 to +13	V
A/BGND	AGND to BGND	-1 to +1	V
V_{dig}	Pin D0, D1, D2, \overline{DET} , CKTTX	-0.4 to 5.5	V
T_j	Max. junction Temperature	150	°C
$V_{btot}^{(1)}$	$V_{btot}= V_{pos} + V_{bat} $. (Total voltage applied to the device supply pins).	90	V
ESD RATING	Human Body Model	±1750	V
	Charged Device Model	±500	V

(1) V_{bat} is self generated by the on chip DC/DC converter and can be programmed via RF1 and RF2.

RF1 and RF2 shall be selected in order to fulfil the a.m limits (see External Components Table page 10)

Table 3. Operating Range

Symbol	Parameter	Value	Unit
V _{pos}	Positive Supply Voltage	4.5 to +12	V
A/BGND	AGND to BGND	-100 to +100	mV
V _{dig}	Pin D0, D1, D2, $\overline{\text{DET}}$, CKTTX, PD	-0.25 to 5.25	V
T _{op}	Ambient Operating Temperature Range	-40 to +85	°C
V _{bat} ⁽¹⁾	Self Generated Battery Voltage	-74 max.	V

(1) Vbat is self generated by the on chip DC/DC converter and can be programmed via RF1 and RF2.

RF1 and RF2 shall be selected in order to fulfil the a.m limits (see External Components Table page 10)

Table 4. Thermal Data

Symbol	Parameter	Value	Unit
R _{th j-amb}	Thermal Resistance Junction to Ambient Typ.	60	°C/W

Table 5. Pin Description

N°	Pin	Function
1	D0	Control Interface: input bit 0.
2	D1	Control Interface: input bit 1.
3	D2	Control interface: input bit 2.
4	PD	Power Down input. Normally connected to CVCC (or to logic level high).
5	Gain SET	Control gain interface: 0 Level R _{xgain} = 0dB T _{xgain} = -6dB 1 Level R _{xgain} = +6dB T _{xgain} = -12dB
6,22,38, 39,40,42	NC	Not connected.
7	$\overline{\text{DET}}$	Logic interface output of the supervision detector (active low).
8	CKTTX	Metering pulse clock input (12 KHz or 16KHz square wave).
9	CTTX1	Metering burst shaping external capacitor.
10	CTTX2	Metering burst shaping external capacitor.
11	RTTX	Metering pulse cancellation buffer output. TTX filter network should be connected to this point. If not used should be left open.
12	FTTX	Metering pulse buffer input this signal is sent to the line and used to perform TTX filtering.
13	RX	4 wire input port (RX input); 300K Ω input impedance. This signal is referred to AGND. If connected to single supply CODEC output it must be DC decoupled with proper capacitor.
14	ZAC1	RX buffer output (the AC impedance is connected from this node to ZAC).
15	ZAC	AC impedance synthesis.
16	RS	Protection resistors image (the image resistor is connected from this node to ZAC).
17	ZB	Balance Network for 2 to 4 wire conversion (the balance impedance ZB is connected from this node to AGND. ZA impedance is connected from this node to ZAC1).
18	CAC	AC feedback input, AC/DC split capacitor (CAC).
19	TX	4 wire output port (TX output). The signal is referred to AGND. If connected to single supply CODEC input it must be DC decoupled with proper capacitor.
20	CZ	Fly-Back compensation
21	VF	Feedback input for DC/DC converter controller.

Table 5. Pin Description (continued)

N°	Pin	Function
23	CLK	Power Switch Controller Clock (typ. 125KHz). This pin can also be connected to CVCC or AGND. When the CLK pin is connected to CVCC an internal auto-oscillation is internally generated and it is used instead of the external clock. When the CLK pin is connected to AGND, the GATE output is disabled.
24	GATE	Driver for external Power MOS transistor (P-channel in Buck-boost configuration, N-channel in Fly-back configuration).
25	RSENSE	Voltage input for current sensing. RSENSE resistor should be connected close to this pin and VPOS pin (Buck-boost) or GND (Fly-back). The PCB layout should minimize the extra resistance introduced by the copper tracks.
26	VPOS	Positive supply input.
27	CVCC	Internal positive voltage supply filter.
28	AGND	Analog Ground, must be shorted with BGND.
29	RLIM	Constant current feed programming pin (via RLIM). RLIM should be connected close to this pin and AGND pin to avoid noise injection.
30	IREF	Internal bias current setting pin. RREF should be connected close to this pin and AGND pin to avoid noise injection.
31	RTH	Off-hook threshold programming pin (via RTH). RTH should be connected close to this pin and AGND pin to avoid noise injection.
32	RD	DC feedback and ring trip input. RD should be connected close to this pin and AGND pin to avoid noise injection.
33	ILTF	Transversal line current image output.
34	CSVR	Battery supply filter capacitor.
35	BGND	Battery Ground, must be shorted with AGND.
36	VBAT	Regulated battery voltage self generated by the device via DC/DC converter. Must be shorted to VBAT1.
37	RING	2 wire port; RING wire (I _b is the current sunk into this pin).
41	TIP	2 wire port; TIP wire (I _a is the current sourced from this pin).
43	CREV	Reverse polarity transition time control. A proper capacitor connected between this pin and AGND is setting the reverse polarity transition time. This is the same transition time used to shape the "trapezoidal ringing" during ringing injection.
44	VBAT1	Frame connection. Must be shorted to VBAT.

3 FUNCTIONAL DESCRIPTION

The STLC3075 is a device specifically developed for WLL VoIP and ISDN-TA applications.

It is based on a SLIC core, on purpose optimised for these applications, with the addition of a DC/DC converter controller to fulfil the WLL and ISDN-TA design requirements.

The SLIC performs the standard feeding, signalling and transmission functions.

It can be set in three different operating modes via the D0, D1, D2 pins of the control logic interface (0 to 3.3V logic levels). The loop status is carried out on the $\overline{\text{DET}}$ pin (active low).

The $\overline{\text{DET}}$ pin is an open drain output to allow easy interfacing with both 3.3V and 5V logic levels.

The four possible SLIC's operating modes are:

- Power Down
- High Impedance Feeding (HI-Z)
- Active
- Ringing

Table 6 shows how to set the different SLIC operating modes.

Table 6. SLIC operating modes.

PD	D0	D1	D2	Operating Mode
0	0	0	X	Power Down
1	0	0	X	H.I. Feeding (HI-Z)
1	0	1	0	Active Normal Polarity
1	0	1	1	Active Reverse Polarity
1	1	1	0	Active TTX injection (N.P.)
1	1	1	1	Active TTX injection (R.P.)
1	1	0	0/1	Ring (D2 bit toggles @ fring)

3.1 DC/DC Converter

The DC/DC converter controller is driving an external power MOS transistor N-Ch plus transformer (Fly-back configuration) or P-Ch plus inductor (BuckBoost configuration), in order to generate the negative battery voltage needed for device operation.

The DC/DC converter controller is synchronised with an external CLK (125KHz typ.) or with an internal clock generated when the pin CLK is connected to CVCC. One R_{sense} in series to PGND supply (FlyBack) or to VPOS supply (BuckBoost) allows to fix the maximum allowed input peak current.

This feature is implemented in order to avoid overload on Vpos supply in case of line transient (ex. ring trip detection). Typ. value is 110m Ω for both configuration and it will guarantee an average current consumption from Vpos < 700mA for BuckBoost configuration and < 1.5A for Fly- Back configuration.

The self generated battery voltage is set to a predefined value in on-hook state.

This value can be adjusted via one external resistor (RF1) and it is typical -50V. When RING mode is selected this value is increased to -70V typ.

Once the line goes in off-hook condition, the DC/DC converter automatically adjusts the generated battery voltage in order to feed the line with a fixed DC current (programmable via RLIM) optimising the power dissipation.

3.2 OPERATING MODES

3.2.1 Power Down

When this mode is selected the SLIC is switched off and the TIP and RING pins are in high impedance.

Also the line detectors are disabled therefore the off-hook condition cannot be detected.

This mode can be selected in emergency condition when it is necessary to cut any current delivered to the line.

This mode is also forced by STLC3075 in case of thermal overload ($T_j > 140^\circ\text{C}$).

In this case the device goes back to the previous status as soon as the junction temperature decrease under the hysteresis threshold.

No AC transmission is possible

3.2.2 High Impedance Feeding (HI-Z)

This operating mode is normally selected when the telephone is in on-hook in order to monitor the line status keeping the power consumption at the minimum.

The output voltage in on-hook condition is equal to the self generated battery voltage (-50V typ).

When off-hook occurs the \overline{DET} becomes active (low logic level).

The off-hook threshold in HI-Z mode is the same value as programmed in ACTIVE mode.

The DC characteristic in HI-Z mode is just equal to the self generated battery with $2x(1600\Omega+R_p)$ in series (see fig. 4), where R_p is the external protection resistance.

No AC transmission is possible.

Figure 4. DC Characteristic in HI-Z Mode.

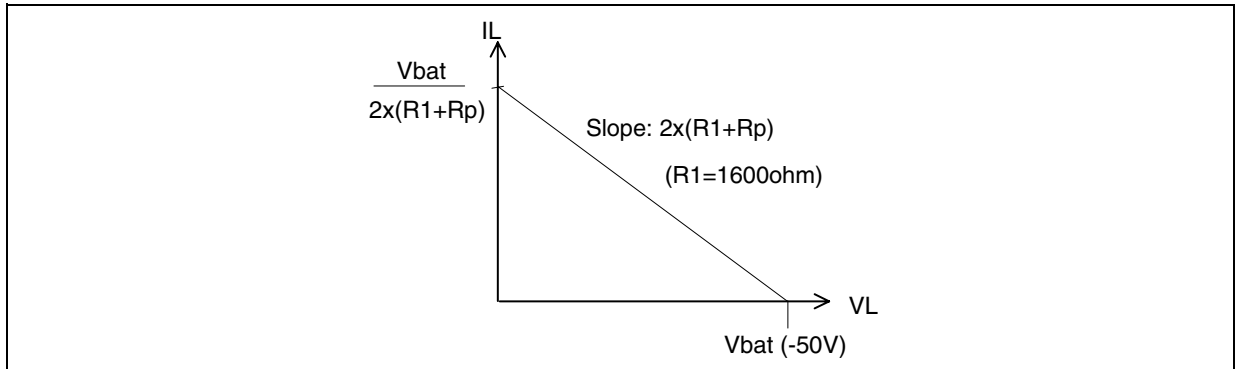

3.2.3 Active

3.2.3.1 DC Characteristics & Supervision

When this mode is selected the STLC3075 provides both DC feeding and AC transmission.

The STLC3075 feeds the line with a constant current fixed by R_{LIM} (20mA to 40mA range). The on-hook voltage is typically 40V allowing on-hook transmission; the self generated V_{bat} is -50V typ.

If the loop resistance is very high and the line current cannot reach the programmed constant current feed value, the STLC3075 behaves like a 40V voltage source with a series impedance equal to the protection resistors $2xR_p$ (typ. $2x50\Omega$). Fig. 5 shows the typical DC characteristic in ACTIVE mode.

The line status (on/off hook) is monitored by the SLIC'S supervision circuit. The off-hook threshold can be programmed via the external resistor R_{TH} in the range from 5mA to 9mA.

Independently on the programmed constant current value, the TIP and RING buffers have a current source capability limited to 80mA typ.

Figure 5. DC characteristic in ACTIVE mode

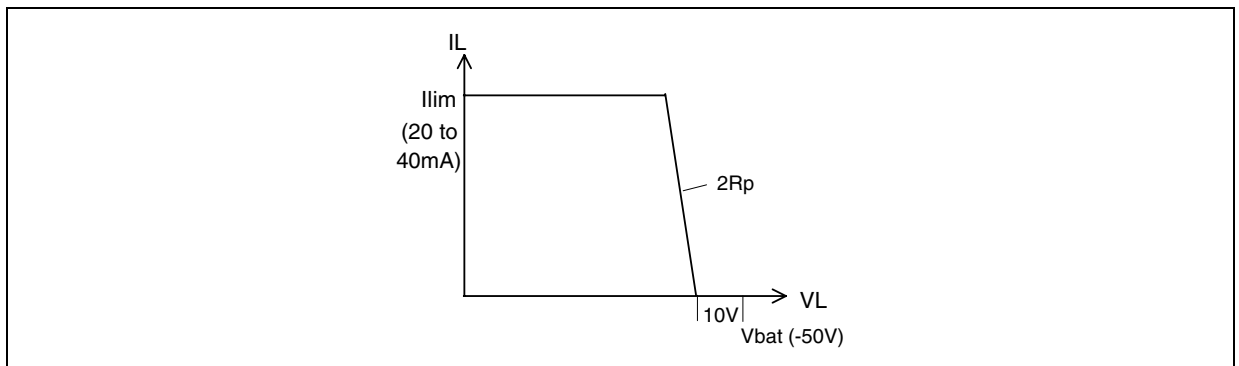

Moreover the power available at V_{bat} is controlled by the DC/DC converter that limits the peak current drawn from the V_{pos} supply. The maximum allowed current peak is set by R_{SENSE} resistor.

3.2.3.2 AC Characteristics

The SLIC provides the standard SLIC transmission functions:

Once in active mode the SLIC can operate with two different Tx, Rx Gain. Setting properly by the Gain set control bit (see table7).

Table 7. Gain Set in Active Mode

Gain set	4 to 2 wire Gain	2 to 4 wire Gain	Impedance Synthesis Scale Factor
0	0dB	-6dB	x 50
1	+6dB	-12dB	x 25

- **Input impedance synthesis:** can be real or complex and is set by a scaled (x50 or x25) external ZAC impedance.
- **Transmit and receive:** The AC signal present on the 2W port (TIP/RING) is transferred to the TX output with a -6dB or -12dB gain and from the RX input to the 2W port with a 0dB or +6dB gain.
- **2 to 4 wire conversion:** The balance impedance can be real or complex, the proper cancellation is obtained by means of two external impedance ZA and ZB

Once in Active mode (D1=1) the SLIC can operate in different states setting properly D0 and D2 control bits (see also Table 8).

Table 8. SLIC states in ACTIVE mode

D0	D1	D2	Operating Mode
0	1	0	Active Normal Polarity
0	1	1	Active Reverse Polarity
1	1	0	Active TTX injection (N.P.)
1	1	1	Active TTX injection (R.P.)

3.2.3.3 Polarity Reversal

The D2 bit controls the line polarity, the transition between the two polarities is performed in a "soft" way. This means that the TIP and RING wire exchange their polarities following a ramp transition (see fig. 6). The transition time is controlled by an external capacitor CREV. This capacitor is also setting the shape of the ringing trapezoidal waveform. When the control pins set battery reversal the line polarity is reversed with a proper transition time set via an external capacitor (CREV).

Figure 6. TIP/RING typical transition from Direct to Reverse Polarity

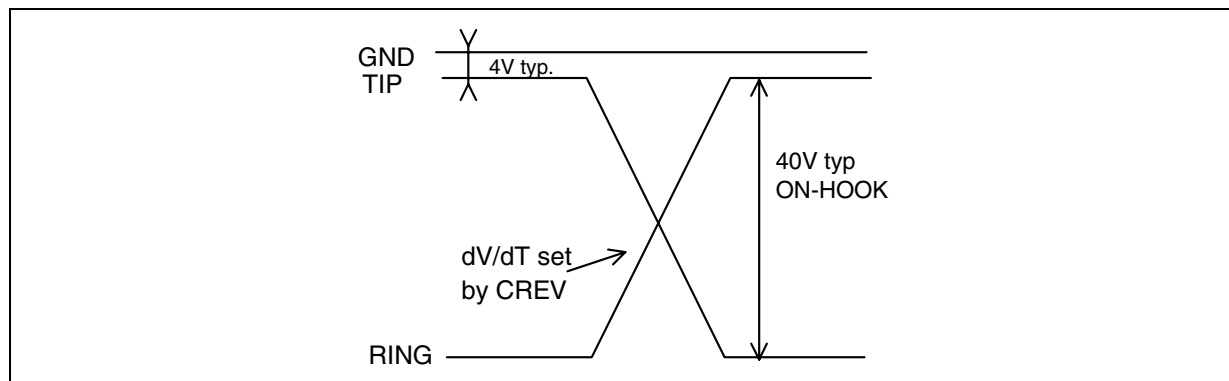

3.2.3.4 Metering Pulse Injection (TTX)

The metering pulses circuit consist of a burst shaping generator that gives a square wave shaped and a low pass filter to reduce the harmonic distortion of the output signal.

The metering pulse is obtained starting from two logic signals:

- CKTTX: is a square wave at the TTX frequency (12 or 16KHz) and should be permanently applied to the CKTTX pin or at least for all the duration of the TTX pulse (including rising and decay phases).
- D0: enable the TTX generation circuit and define the TTX pulse duration.

These two signals are processed by a dedicated circuitry integrated on chip that generate the metering pulse as an amplitude modulated shaped squarewave (SQTTX) (see fig. 7).

Both the amplitude and the envelope of the squarewave (SQTTX) can be programmed by means of external components. In particular the amplitude is set by the two resistors RLV and the shaping by the capacitor CS.

Figure 7. Metering pulse generation circuit.

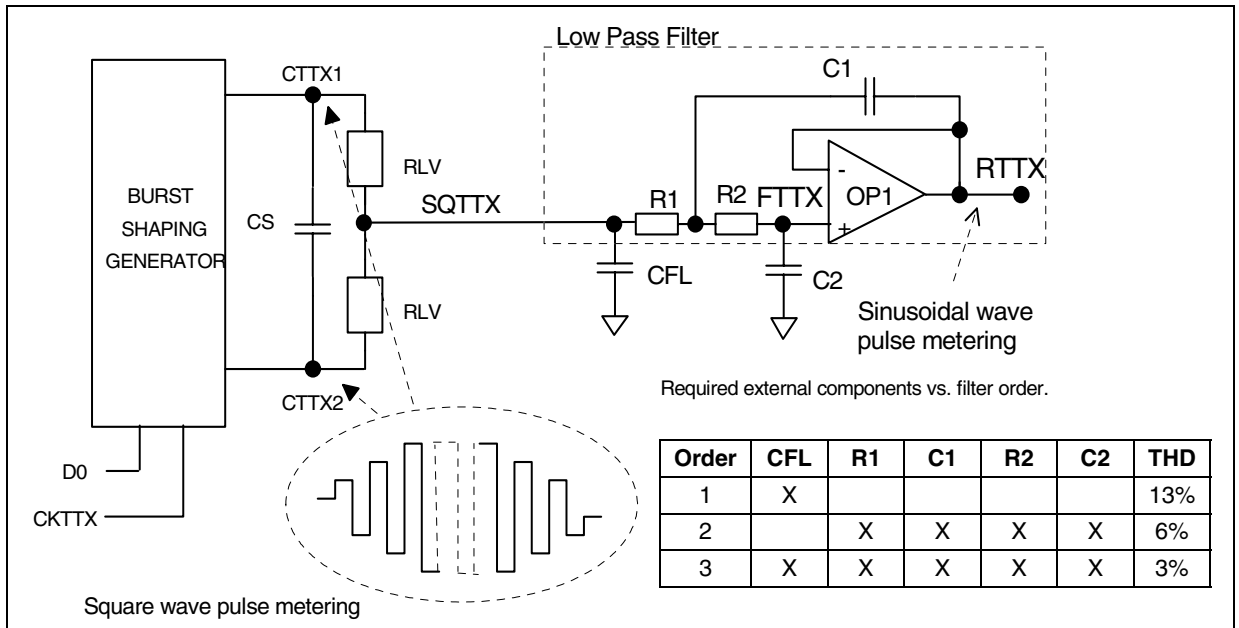

The waveform so generated is then filtered and injected on the line.

The low pass filter can be obtained using the integrated buffer OP1 connected between pin FTTX (OP1 non inverting input) and RTTX (OP1 output) (see fig. 7) and implementing a "Sallen and Key" configuration. Depending on the external components count it is possible to build an optimised application depending on the distortion level required. In particular harmonic distortion levels equal to 13%, 6% and 3% can be obtained respectively with first, second and third order filters (see fig. 7).

The circuit showed in the "Application diagram" is related to the simple first order filter.

Once the shaped and filtered signal is obtained at RTTX buffer output it is injected on the TIP/RING pins with a +6dB gain or +12dB gain.

It should be noted that this is the nominal condition obtained in presence of ideal TTX echo cancellation (obtained via proper setting of RTTX and CTTX).

In addition the effective level obtained on the line will depend on the line impedance and the protection resistors value. In the typical application (TTX line impedance =200Ω , RP = 50Ω, and ideal TTX echo cancellation) the metering pulse level on the line will be 1.33 or 2.66 times the level applied to the RTTX pin.

As already mentioned the metering pulse echo cancellation is obtained by means of two external components (RTTX and CTTX) that should match the line impedance at the TTX frequency. This simple network has a double effect:

- Synthesize a low output impedance at the TIP/RING pins at the TTX frequency.
- Cut the eventual TTX echo that will be transferred from the line to the TX output.

3.2.4 Ringing

When this mode is selected STLC3075 self generate an higher negative battery (-70V typ.) in order to allow a balanced ringing signal of typically 65Vpeak.

In this condition both the DC and AC feedback loop are disabled and the SLIC line drivers operate as voltage buffers. The ring waveform is obtained toggling the D2 control bit at the desired ring frequency. This bit in fact controls the line polarity (0=direct; 1= reverse). As in the ACTIVE mode the line voltage transition is performed with a ramp transition, obtaining in this way a trapezoidal balanced ring waveform (see fig. 8). The shaping is defined by the CREV external capacitor.

Figure 8. TIP/RING typical ringing waveform

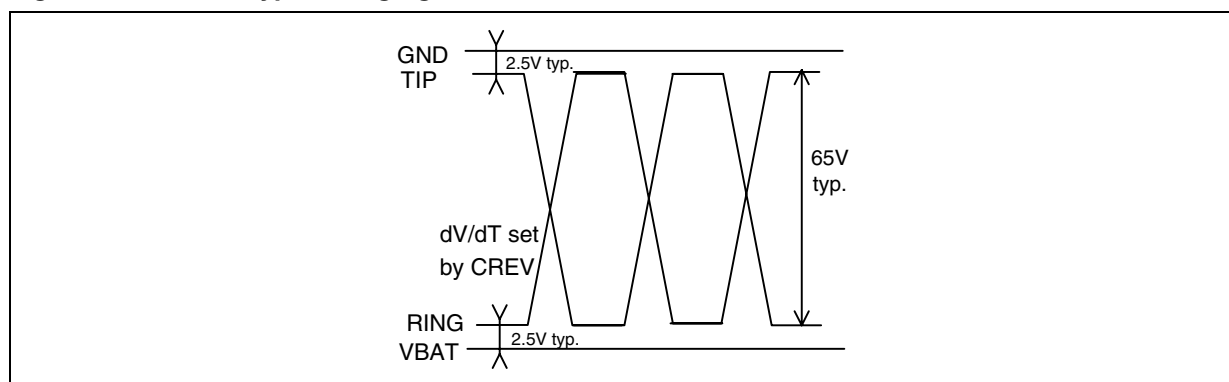

Selecting the proper capacitor value it is possible to get different crest factor values.

The following table shows the crest factor values obtained with a 20Hz and 25Hz ring frequency and with 1REN. These value are valid either with European or USA specification:

Table 9.

CREV	CREST FACTOR @20Hz	CREST FACTOR @25Hz
22nF	1.2	1.26
27nF	1.25	1.32
33nF	1.33	Not significant (*)

(*) Distorsion already less than 10%.

The ring trip detection is performed sensing the variation of the AC line impedance from on hook (relatively high) to off-hook (low). This particular ring trip method allows to operate without DC offset superimposed on the ring signal and therefore obtaining the maximum possible ring level on the load starting from a given negative battery.

It should be noted that such a method is optimised for operation on short loop applications and may not operate properly in presence of long loop applications (> 500Ω).

Once ring trip is detected, the \overline{DET} output is activated (logic level low), at this point the card controller or a simple logic circuit should stop the D2 toggling in order to effectively disconnect the ring signal and then set the STLC3075 in the proper operating mode (normally ACTIVE).

3.2.4.1 Ring Level in Presence of More Telephone in Parallel

As already mentioned above the maximum current that can be drawn from the Vpos supply is controlled and limited via the external RSENSE.

This will limit also the power available at the self generated negative battery.

If for any reason the ringer load is too low the self generated battery will drop in order to keep the power

consumption to the fixed limit and therefore also the ring voltage level will be reduced.

In the typical application with $R_{SENSE} = 110\text{m}\Omega$ the peak current from V_{pos} is limited to about 900mA, which correspond to an average current of 700mA max. In this condition the STLC3075 can drive up to 3REN with a ring frequency $f_r=25\text{Hz}$ ($1REN = 1800\Omega + 1.0\mu\text{F}$, European standard).

In order to drive up to 5REN ($1REN= 6930\Omega + 8\mu\text{F}$, US standard) it is necessary to modify the external components as follows:

$$C_{REV} = 15\text{nF}$$

$$R_D = 2.2\text{K}\Omega$$

$$R_{SENSE} = 100\text{m}\Omega$$

3.2.5 Layout Recommendation

A properly designed PCB layout is a basic issue to guarantee a correct behaviour and good noise performances.

Particular care must be taken on the ground connection and in this case the star configuration allows surely to avoid possible problems (see Application Diagram Figg. 11,12).

The ground of the power supply (VPOS) has to be connected to the center of the star, let's call this point SYSTEM-GND. This point should show a resistance as low as possible, that means it should be a ground plane.

In particular to avoid noise problems the layout should prevent any coupling between the DC/DC converter components and analog pins that are referred to AGND (ex: R_D , IREF, RTH, RLIM, VF). As a first recommendation the components CV, L, T1, D1, CVPOS, RSENSE should be kept as close as possible to each other and isolated from the other components.

Additional improvements can be obtained:

- decoupling the center of the star from the analog ground of STLC3075 using small chokes.
- adding a capacitor in the range of 100nF between VPOS and AGND in order to filter the switch frequency on VPOS.

3.2.6 External Components List

In order to properly define the external components value the following system parameters have to be defined:

- The AC input impedance shown by the SLIC at the line terminals "Zs" to which the return loss measurement is referred. It can be real (typ. 600Ω) or complex.
- The AC balance impedance, it is the equivalent impedance of the line "ZI" used for evaluation of the trans-hybrid loss performances (2/4 wire conversion). It is usually a complex impedance.
- The value of the two protection resistors R_p in series with the line termination. The line impedance at the TTX frequency "Zltx".
- The metering pulse level amplitude measured at line termination " V_{LOTTX} ". In case of low order filtering, V_{LOTTX} represents the amplitude (V_{rms}) of the fundamental frequency component. (typ 12 or 16KHz).
- Pulse metering envelope rise and decay time constant " τ ".
- The slope of the ringing waveform " $\Delta V_{TR}/\Delta T$ ".
- The value of the constant current limit current " I_{lim} ".
- The value of the off-hook current threshold " I_{TH} ".
- The value of the ring trip rectified average threshold current " I_{RTH} ".
- The value of the required self generated negative battery " V_{BATR} " in ring mode (max value is 70V). This value can be obtained from the desired ring peak level + 5V.
- The value of the maximum current peak drawn from V_{pos} "IPK".

Table 10. External Components for BuckBoost configuration

Name	Function	Formula	Typ. Value
RREF	Bias setting current	$RREF = 1.3/I_{bias}$ $I_{bias} = 50\mu A$	26k Ω 1%
CSVR	Negative Battery Filter	$CSVR = 1/(2\pi \cdot fp \cdot 1.8M\Omega)$ $fp = 50Hz$	1.5nF 10% 100V
RD	Ring Trip threshold setting resistor	$RD = 100/I_{RTH}$ $2K\Omega < RD < 5K\Omega$	4.12k Ω 1% @ $I_{RTH} = 24mA$
CAC	AC/DC split capacitance		22 μF 20% 15V @ $RD = 4.12k\Omega$
RP	Line protection resistor	$R_p > 30\Omega$	50 Ω 1%
RLIM	Current limiting programming	$RLIM = 1300/I_{lim}$ $32.5k\Omega < RLIM < 65k\Omega$	52.3k Ω 1% @ $I_{lim} = 25mA$
RTH	Off-hook threshold programming (ACTIVE mode)	$RTH = 290/I_{TH}$ $27k\Omega < RTH < 52k\Omega$	32.4k Ω 1% @ $I_{TH} = 9mA$
CREV	Reverse polarity transition time programming	$CREV = ((1/3750) \cdot \Delta T/\Delta V_{TR})$	22nF 10% 10V @ 12V/ms
RDD	Pull up resistors		100k Ω
CVCC	Internally supply filter capacitor		100nF 20% 10V
CVpos	Positive supply filter capacitor with low impedance for switch mode power supply		100 μF (4)
CV	Battery supply filter capacitor with low impedance for switch mode power supply		100 μF 20% 100V (5)
CVB	High frequency noise filter		470nF 20% 100V
CRD (6)	High frequency noise filter		100nF 10% 15V
Q1	DC/DC converter switch P ch. MOS transistor	$R_{DS(ON)} \leq 1.2\Omega$, $V_{DS} = -100V$ Total gate charge=20nC max. with $V_{GS}=4.5V$ and $V_{DS}=1V$ $I_D > 500mA$	Possible choices: IRF9510 or IRF9520 or IRF9120 or equivalent
D1	DC/DC converter series diode	$V_f > 100V$, $t_{RR} \leq 50ns$	SMBYW01-200 or equivalent
RSENSE	DC/DC converter peak current limiting	$R_{SENSE} = 100mV/I_{PK}$	110m Ω @ $I_{PK} = 900mA$
RF1	Negative battery programming level	$250K\Omega < RF1 < 300K\Omega$ (7)	300k Ω 1% @ $V_{BATR} = -70V$
RF2	Negative battery programming level		9.1k Ω 1%
L	DC/DC converter inductor	DC resistance $\leq 0.1\Omega$ (8)	L=100 μH SUMIDA CDRH125 or equivalent

Table 11. External Components for Fly-back configuration

Name	Function	Formula	Typ. Value
RREF	Bias setting current	$RREF = 1.3/I_{bias}$; $I_{bias} = 50\mu A$	26k Ω 1%
CSVR	Negative Battery Filter	$CSVR = 1/(2\pi \cdot fp \cdot 1.8M\Omega)$ $fp = 50Hz$	1.5nF 10% 100V
RD	Ring Trip threshold setting resistor	$RD = 100/I_{RTH}$ $2K\Omega < RD < 5K\Omega$	4.12k Ω 1% @ $I_{RTH} = 24mA$
CAC	AC/DC split capacitance		22 μF 20% 15V @ $RD = 4.12k\Omega$

Table 11. External Components for Fly-back configuration (continued)

Name	Function	Formula	Typ. Value
RP	Line protection resistor	$R_p > 30\Omega$	50 Ω 1%
RLIM	Current limiting programming	$RLIM = 1300/I_{lim}$ $32.5k\Omega < RLIM < 65k\Omega$	52.3k Ω 1% @ $I_{lim} = 25mA$
RTH	Off-hook threshold programming (ACTIVE mode)	$RTH = 290/I_{TH}$ $27k\Omega < RTH < 52k\Omega$	32.4k Ω 1% @ $I_{TH} = 9mA$
CREV	Reverse polarity transition time programming	$CREV = ((1/3750) \cdot \Delta T/\Delta V_{TR})$	22nF 10% 10V @ 12V/ms
RDD	Pull up resistors		100k Ω
CVCC	Internally supply filter capacitor		100nF 20% 10V
CVpos	Positive supply filter capacitor with low impedance for switch mode power supply		100 μ F(4)
CV	Battery supply filter capacitor with low impedance for switch mode power supply		100 μ F 20% 100V (5)
CVB	High frequency noise filter		470nF 20% 100V
CRD (6)	High frequency noise filter		100nF 10% 15V
CZ	Fly-Back compensation capacitor		2.2nF, 20%
CSF	Sense Filter capacitor		120pF, 20%
RSF	Sense Filter resistor		1k Ω
RSENSE	DC/DC converter peak current limiting	$R_{SENSE} = 375mV/I_{PK}$	110m Ω @ $I_{PK} = 3.3A$
Q1	DC/DC converter switch Nchan MOS transistor	$R_{DS(ON)} \leq 0.05\Omega$, $V_{DSS} = 30V$ $V_{DG} = 30V$, $I_D = 6.5A$ Low threshold drive	STN4NF03L or equivalent
D1	DC/DC converter series diode	$V_r > 350V$, $t_{RR} \leq 80ns$	SMBYTW01-400 or equivalent
T1	DC/DC Converter transformer	Fly-Back transformer 4W, Turns Ratio 1:16 fro VPOS range from 4.5V to 8.5V	Tyco COEV MAGNETICS MGPWG-00007
T1	DC/DC Converter transformer	Fly-Back transformer 4W, Turns Ratio 1:8 fro VPOS range from 8.5V to 12V	Tyco COEV MAGNETICS MGPWG-00008
RF1	Negative battery programming level	$250K\Omega < RF1 < 300K\Omega$ (7)	300k Ω 1% @ $V_{BATR} = -70V$
RF2	Negative battery programming level		9.1k Ω 1%

Table 12. External Components @Gain Set = 0

Name	Function	Formula	Typ. Value
RS	Protection resistance image	$RS = 50 \cdot (2R_p)$	5k Ω @ $R_p = 50\Omega$
ZAC	Two wire AC impedance	$ZAC = 50 \cdot (Z_s - 2R_p)$	25k Ω 1% @ $Z_s = 600\Omega$
ZA (1)	SLIC impedance balancing network	$ZA = 50 \cdot Z_s$	30k Ω 1% @ $Z_s = 600\Omega$
ZB (1)	Line impedance balancing network	$ZB = 50 \cdot Z_l$	30k Ω 1% @ $Z_l = 600\Omega$
CCOMP	AC feedback loop compensation	$f_o = 250kHz$ $CCOMP = 1/(2\pi \cdot f_o \cdot 100 \cdot (R_p))$	120pF 10% 10V @ $R_p = 50\Omega$
CH	Trans-Hybrid Loss frequency compensation	$CH = CCOMP$	120pF 10% 10V
RRTX (3)	Pulse metering cancellation resistor	$RRTX = 50Re (Z_{ltx} + 2R_p)$	15k Ω @ $Z_{ltx} = 200\Omega$ real

Table 12. External Components @Gain Set = 0 (continued)

Name	Function	Formula	Typ. Value
CTTX (3)	Pulse metering cancellation capacitor	$CTTX = 1/\{50 \cdot 2\pi \cdot f_{ttx} \cdot [-\ln(Z_{ltx})]\}$	100nF 10% 10V (2) @ $Z_{ltx} = 200\Omega$ real
RLV	Pulse metering level resistor	$RLV = 63.3 \cdot 10^3 \cdot \alpha \cdot V_{LOTTX}$ $\alpha = (Z_{ltx} + 2R_p)/ Z_{ltx} $	16.2k Ω @ $V_{LOTTX} = 170mV_{rms}$
CS	Pulse metering shaping capacitor	$CS = \tau/(2 \cdot RLV)$	100nF 10% 10V @ $\tau = 3.2ms$, $RLV = 16.2k\Omega$
CFL	Pulse metering filter capacitor	$CFL = 2/(2\pi \cdot f_{ttx} \cdot RLV)$	1.5nF 10% 10V @ $f_{ttx} = 12kHz$ $RLV = 16.2k\Omega$

Table 13. External Components @Gain Set = 1

Name	Function	Formula	Typ. Value
RS	Protection resistance image	$RS = 25 \cdot (2R_p)$	2.55k Ω @ $R_p = 50\Omega$
ZAC	Two wire AC impedance	$ZAC = 25 \cdot (Z_s - 2R_p)$	12.5k Ω 1% @ $Z_s = 600\Omega$
ZA (1)	SLIC impedance balancing network	$ZA = 25 \cdot Z_s$	15k Ω 1% @ $Z_s = 600\Omega$
ZB (1)	Line impedance balancing network	$ZB = 25 \cdot Z_l$	15k Ω 1% @ $Z_l = 600\Omega$
CCOMP	AC feedback loop compensation	$f_o = 250kHz$ $CCOMP = 2/(2\pi \cdot f_o \cdot 100 \cdot (R_p))$	220pF 10% 10V @ $R_p = 50\Omega$
CH	Trans-Hybrid Loss frequency compensation	$CH = CCOMP$	220pF 10% 10V
RRTX (3)	Pulse metering cancellation resistor	$RRTX = 25Re(Z_{ltx} + 2R_p)$	7.5k Ω @ $Z_{ltx} = 200\Omega$ real
CTTX (3)	Pulse metering cancellation capacitor	$CTTX = 1/25 \cdot 2\pi \cdot f_{ttx} \cdot [-\ln(Z_{ltx})]$	100nF 10% 10V (2) @ $Z_{ltx} = 200\Omega$ real
RLV	Pulse metering level resistor	$RLV = 31.7 \cdot 10^3 \cdot \alpha \cdot V_{LOTTX}$ $\alpha = (Z_{ltx} + 2R_p)/ Z_{ltx} $	16.2k Ω @ $V_{LOTTX} = 340mV_{rms}$
CS	Pulse metering shaping capacitor	$CS = \tau/(2 \cdot RLV)$	100nF 10% 10V @ $\tau = 3.2ms$, $RLV = 16.2k\Omega$
CFL	Pulse metering filter capacitor	$CFL = 2/(2\pi \cdot f_{ttx} \cdot RLV)$	1.5nF 10% 10V @ $f_{ttx} = 12kHz$ $RLV = 16.2k\Omega$

(1) In case $Z_s=Z_l$, ZA and ZB can be replaced by two resistors of same value: $RA=RB=|Z_s|$.

(2) In this case CTTX is just operating as a DC decoupling capacitor ($f_p=100Hz$).

(3) Defining ZTTX as the impedance of RRTX in series with CTTX, RRTX and CTTX can also be calculated from the following formula:
 $ZTTX=50 \cdot (Z_{ltx} + 2R_p)$.

(4) CVpos should be defined depending on the power supply current capability and maximum allowable ripple.

(5) For low ripple application use $2 \times 47\mu F$ in parallel.

(6) Can be saved if proper PCB layout avoid noise coupling on RD pin (high impedance input).

(7) RF1 sets the self generated battery voltage in RING and ACTIVE($I_l=0$) mode as follows:

	267k Ω	280k Ω	294k Ω	300k Ω
$V_{BAT(ACTIVE)}$	-46V	-48V	-49V	-50V
$V_{BATR(RING)}$	-62V	-65V	-68V	-70V

V_{BATR} should be defined considering the ring peak level required ($V_{ringpeak}=V_{BATR}-6V$ typ.).

The above relation is valid provided that the V_{pos} power supply current capability and the RSENSE programming allow to source all the current requested by the particular ringer load configuration.

(8) For high efficiency in HI-Z mode coil resistance @ 125kHz must be $< 3\Omega$

Figure 9. Application Diagram with N-Channel.

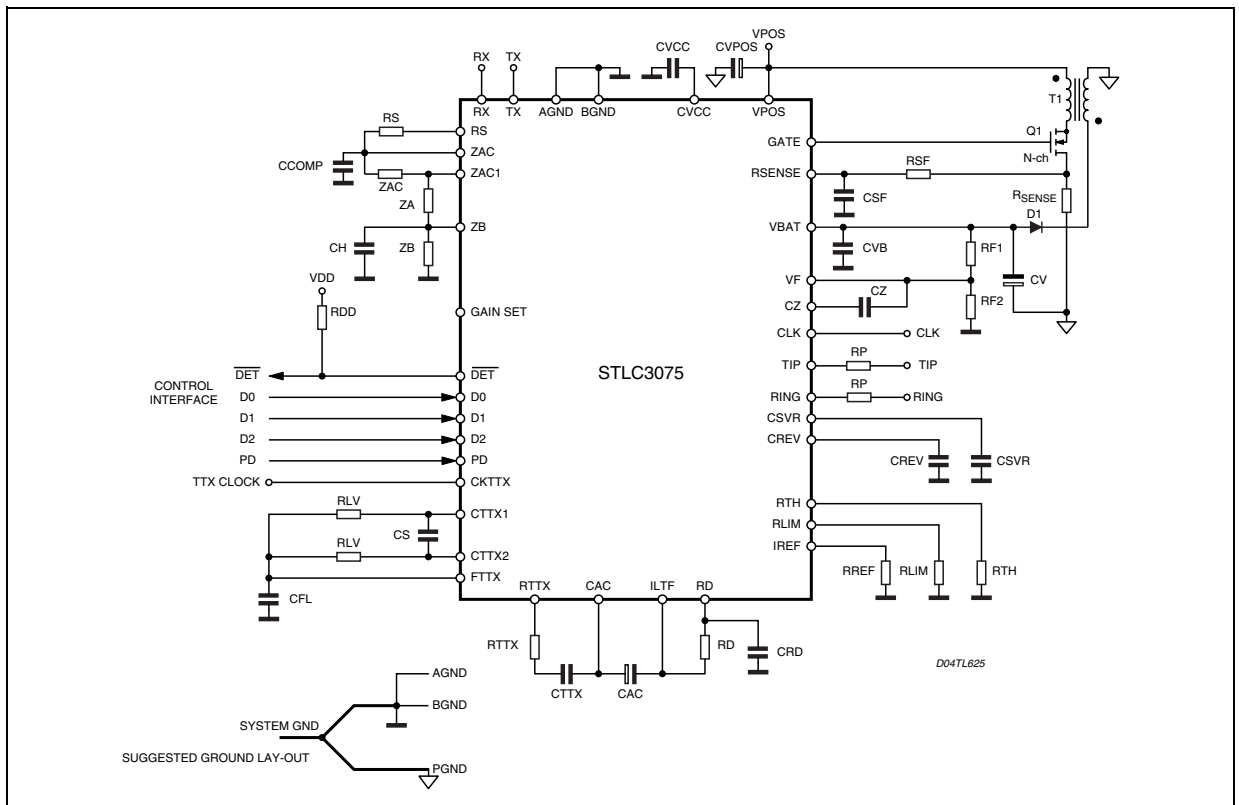

Figure 10. Application Diagram without Metering Pulse Generation with N-Channel.

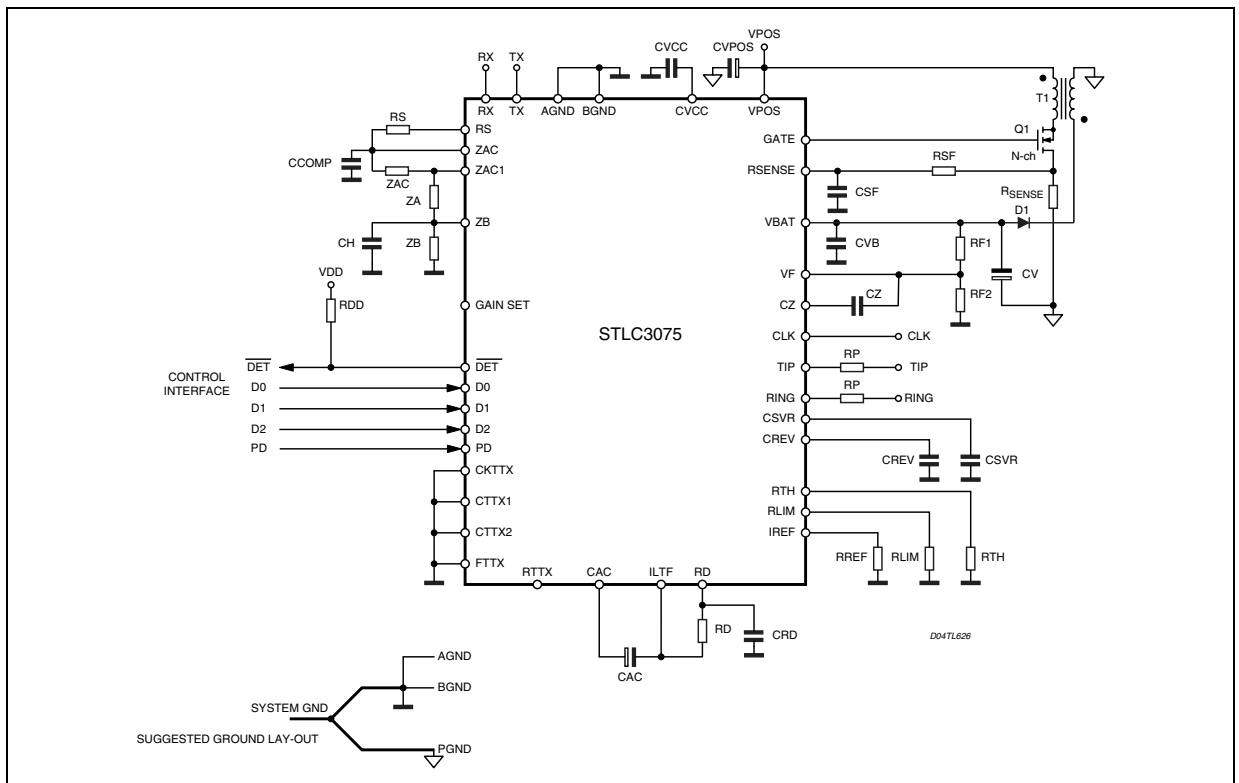

Figure 11. Application Diagram with P-Channel.

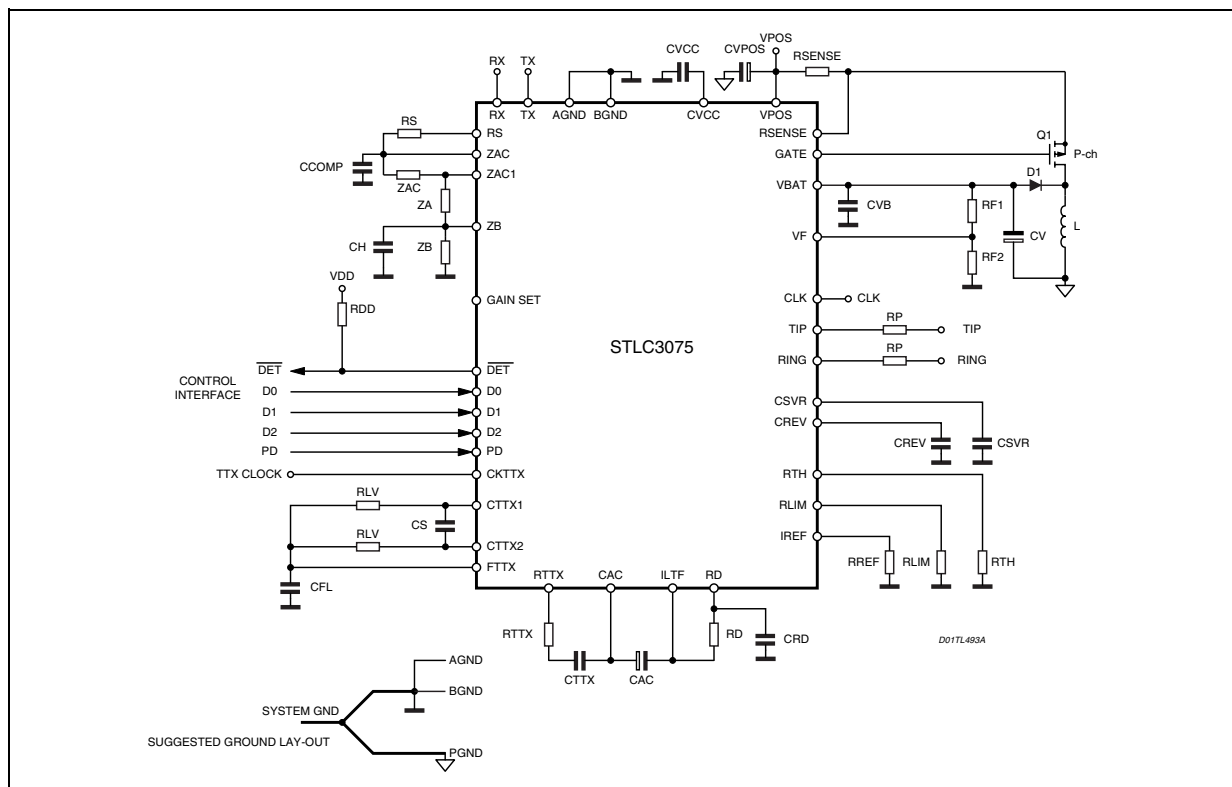
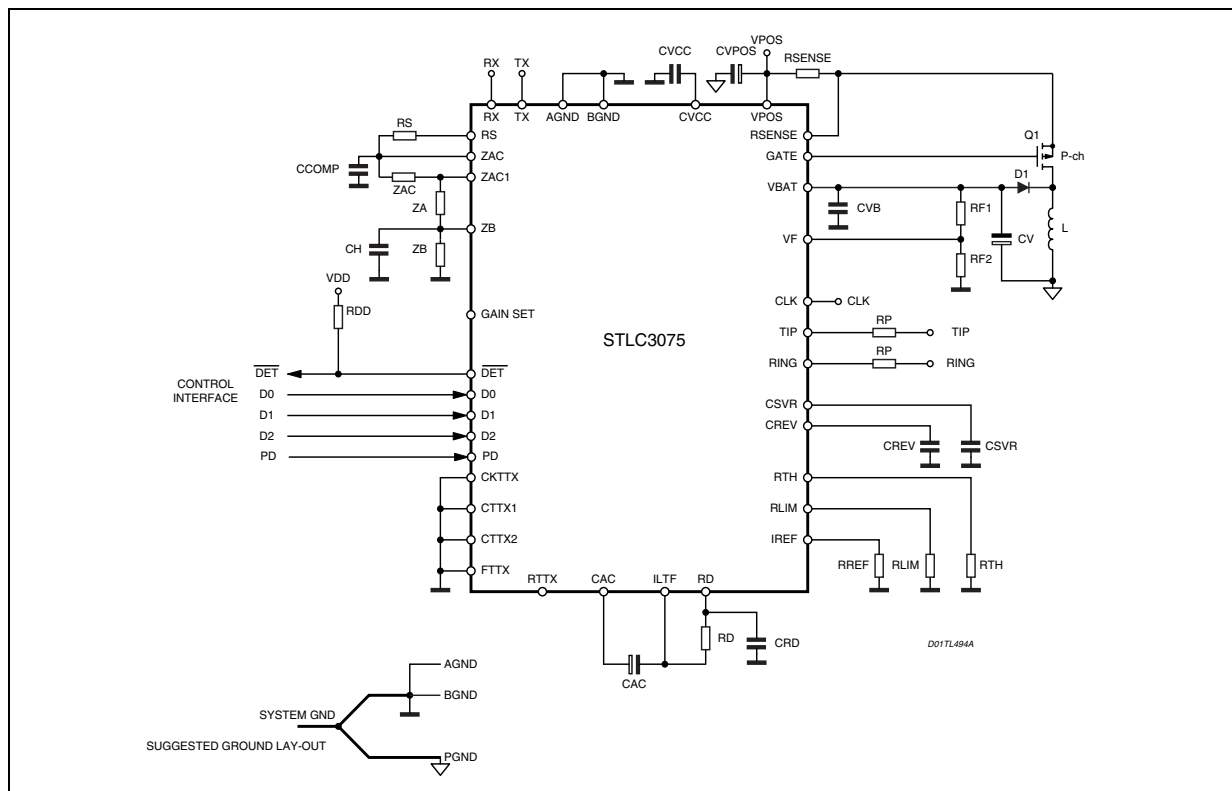

Figure 12. Application Diagram without Metering Pulse Generation.



4 ELECTRICAL CHARACTERISTICS

Test conditions: $V_{pos} = 6.0V$, AGND = BGND, Normal Polarity, $T_{amb} = 25^{\circ}C$.

External components as listed in the "Typical Values" column of EXTERNAL COMPONENTS Table.

Note: Testing of all parameter is performed at $25^{\circ}C$. Characterisation as well as design rules used allow correlation of tested performances at other temperatures. All parameters listed here are met in the operating range: -40 to $+85^{\circ}C$.

Symbol	Parameter	Test Condition	Min.	Typ.	Max.	Unit
DC CHARACTERISTICS						
V_{lohi}	Line voltage	$I_I = 0$, HI-Z (High impedance feeding) $T_{amb} = 0$ to $85^{\circ}C$	44	50		V
V_{lohi}	Line voltage	$I_I = 0$, HI-Z (High impedance feeding) $T_{amb} = -40$ to $85^{\circ}C$	42	48		V
V_{loa}	Line voltage	$I_I = 0$, ACTIVE $T_{amb} = 0$ to $85^{\circ}C$	33	40		V
V_{loa}	Line voltage	$I_I = 0$, ACTIVE $T_{amb} = -40$ to $85^{\circ}C$	31	37		V
I_{lim}	Lim. current programming range	ACTIVE mode	20		40	mA
I_{lima}	Lim. current accuracy	ACTIVE mode. Rel. to programmed value 20mA to 40mA	-10		10	%
Rfeed HI	Feeding resistance	HI-Z (High Impedance feeding)	2.4		3.6	k Ω
AC CHARACTERISTICS						
L/T	Long. to transv. (see Appendix for test circuit)	$R_p = 50\Omega$, 1% tol., ACTIVE N. P., $R_L = 600\Omega$ (*) $f = 300$ to $3400Hz$	50	58		dB
T/L	Transv. to long. (see Appendix for test circuit)	$R_p = 50\Omega$, 1% tol., ACTIVE N. P., $R_L = 600\Omega$ (*) $f = 300$ to $3400Hz$	40	45		dB
T/L	Transv. to long. (see Appendix for test circuit)	$R_p = 50\Omega$, 1% tol., ACTIVE N. P., $R_L = 600\Omega$ (*) $f = 1kHz$	48	53		dB
2WRL	2W return loss	300 to 3400Hz, ACTIVE N. P., $R_L = 600\Omega$ (*)	22	26		dB
THL	Trans-hybrid loss	300 to 3400Hz, $20\log VRX/VTXI $, ACTIVE N. P., $R_L = 600\Omega$ (*)	30			dB
Ovl	2W overload level	at line terminals on ref. imped. ACTIVE N. P., $R_L = 600\Omega$ (*)	3.2			dBm
TXoff	TX output offset	ACTIVE N. P., $R_L = 600\Omega$ (*)	-250		250	mV
G24	Transmit gain abs.	0dBm @ 1020Hz, ACTIVE N. P., $R_L = 600\Omega$ (*)	-6.4		-5.6	dB
G42	Receive gain abs.	0dBm @ 1020Hz, ACTIVE N. P., $R_L = 600\Omega$ (*)	-0.4		0.4	dB

4 ELECTRICAL CHARACTERISTICS

Test conditions: $V_{pos} = 6.0V$, AGND = BGND, Normal Polarity, $T_{amb} = 25^{\circ}C$.

External components as listed in the "Typical Values" column of EXTERNAL COMPONENTS Table.

Note: Testing of all parameter is performed at $25^{\circ}C$. Characterisation as well as design rules used allow correlation of tested performances at other temperatures. All parameters listed here are met in the operating range: -40 to $+85^{\circ}C$.

Symbol	Parameter	Test Condition	Min.	Typ.	Max.	Unit
G24f	TX gain variation vs. freq.	rel. 1020Hz; 0dBm, 300 to 3400Hz, ACTIVE N. P., $R_L = 600\Omega$ (*)	-0.12		0.12	dB
G24f	RX gain variation vs. freq.	rel. 1020Hz; 0dBm, 300 to 3400Hz, ACTIVE N. P., $R_L = 600\Omega$ (*)	-0.12		0.12	dB
V2Wp	Idle channel noise at line 0dB gainset	psophometric filtered ACTIVE N. P., $R_L = 600\Omega$ (*) $T_{amb} = 0$ to $+85^{\circ}C$		-73	-68	dBmp
V2Wp	Idle channel noise at line 0dB gainset	psophometric filtered ACTIVE N. P., $R_L = 600\Omega$ (*) $T_{amb} = -40$ to $+85^{\circ}C$		-68		dBmp
V4Wp	Idle channel noise at line 0dB gainset	psophometric filtered ACTIVE N. P., $R_L = 600\Omega$ (*) $T_{amb} = 0$ to $+85^{\circ}C$		-75	-70	dBmp
V4Wp	Idle channel noise at line 0dB gainset	psophometric filtered ACTIVE N. P., $R_L = 600\Omega$ (*) $T_{amb} = -40$ to $+85^{\circ}C$		-75		dBmp
Thd	Total Harmonic Distortion	ACTIVE N. P., $R_L = 600\Omega$ (*)			-44	dB
VTTX	Metering pulse level on line	ACTIVE - TTX $Z_I = 200\Omega$ ftx = 12kHz	130	170		mVrms
CLKfreq	CLK operating range		-10%	125	10%	kHz

(*) R_L : Line Resistance

RING

Vring	Line voltage	RING D2 toggling @ fr = 25Hz Load = 3REN; Crest Factor = 1.25 1REN = $1800\Omega + 1.0\mu F$ $T_{amb} = 0$ to $+85^{\circ}C$	45	49		Vrms
Vring	Line voltage	RING D2 toggling @ fr = 25Hz Load = 3REN; Crest Factor = 1.25 1REN = $1800\Omega + 1.0\mu F$ $T_{amb} = -40$ to $+85^{\circ}C$	44	48		Vrms

DETECTORS

IOFFTHA	Off/hook current threshold	ACT. mode, $R_{TH} = 32.4k\Omega$ 1% (Prog. ITH = 9mA)	10.5			mA
ROFTHA	Off/hook loop resistance threshold	ACT. mode, $R_{TH} = 32.4k\Omega$ 1% (Prog. ITH = 9mA)			3.4	k Ω
IONTHA	On/hook current threshold	ACT. mode, $R_{TH} = 32.4k\Omega$ 1% (Prog. ITH = 9mA)			6	mA

4 ELECTRICAL CHARACTERISTICS

Test conditions: $V_{pos} = 6.0V$, AGND = BGND, Normal Polarity, $T_{amb} = 25^{\circ}C$.

External components as listed in the "Typical Values" column of EXTERNAL COMPONENTS Table.

Note: Testing of all parameter is performed at $25^{\circ}C$. Characterisation as well as design rules used allow correlation of tested performances at other temperatures. All parameters listed here are met in the operating range: -40 to $+85^{\circ}C$.

Symbol	Parameter	Test Condition	Min.	Typ.	Max.	Unit
RONTHA	On/hook loop resistance threshold	ACT. mode, $R_{TH} = 32.4k\Omega$ 1% (Prog. ITH = 9mA)	8			$k\Omega$
IOFFTHI	Off/hook current threshold	Hi Z mode, $R_{TH} = 32.4k\Omega$ 1% (Prog. ITH = 9mA)	10.5			mA
ROFFTHI	Off/hook loop resistance threshold	Hi Z mode, $R_{TH} = 32.4k\Omega$ 1% (Prog. ITH = 9mA)			800	Ω
IONTHI	On/hook current threshold	Hi Z mode, $R_{TH} = 32.4k\Omega$ 1% (Prog. ITH = 9mA)			6	mA
RONTHI	On/hook loop resistance threshold	Hi Z mode, $R_{TH} = 32.4k\Omega$ 1% (Prog. ITH = 9mA)	8			$k\Omega$
Irt	Ring Trip detector threshold range	RING	20		50	mA
Irt _a	Ring Trip detector threshold accuracy	RING	-15		15	%
Trtd	Ring trip detection time	RING		TBD		ms
Td	Dialling distortion	ACTIVE	-1		1	ms
Rlrt ⁽¹⁾	Loop resistance				500	Ω
ThAl	T _j for th. alarm activation			160		$^{\circ}C$

(1) Rlrt = Maximum loop resistance (incl. telephone) for correct ring trip detection.

DIGITAL INTERFACE

INPUTS: D0, D1, D2, PD, CLK

OUTPUTS: DET

V _{ih}	Input high voltage		2			V
V _{il}	Input low voltage				0.8	V
I _{ih}	Input high current		-10		10	μA
I _{il}	Input low current		-10		10	μA
V _{ol}	Output low voltage	I _{ol} = 1mA			0.45	V

PSRR AND POWER CONSUMPTION

PSERRC	Power supply rejection V _{pos} to 2W port	Vripple = 100mV _{rms} 50 to 4000Hz	26	36		dB
I _{vpos}	V _{pos} supply current @ I _{ii} = 0	HI-Z On-Hook ACTIVE On-Hook, RING (line open)		13 50 55	25 80 90	mA mA mA
I _{pk}	Peak current limiting accuracy	RING Off-Hook RSENSE = 110m Ω	-20%	950	+20%	mApk

5 APPENDIX A

5.1 STLC3075 Test Circuits

Referring to the application diagram shown in fig. 11 and using as external components the Typ. Values specified in the "External Components" Tables 10 and 12 (pages 11 and 12) find below the proper configuration for each measurement.

All measurements requiring DC current termination should be performed using "Wandel & Goltermann DC Loop Holding Circuit GH-1" or equivalent.

Figure 13. 2W Return Loss

$$2WRL = 20\text{Log}(|Z_{\text{ref}} + Z_s|/|Z_{\text{ref}} - Z_s|) = 20\text{Log}(E/2V_s)$$

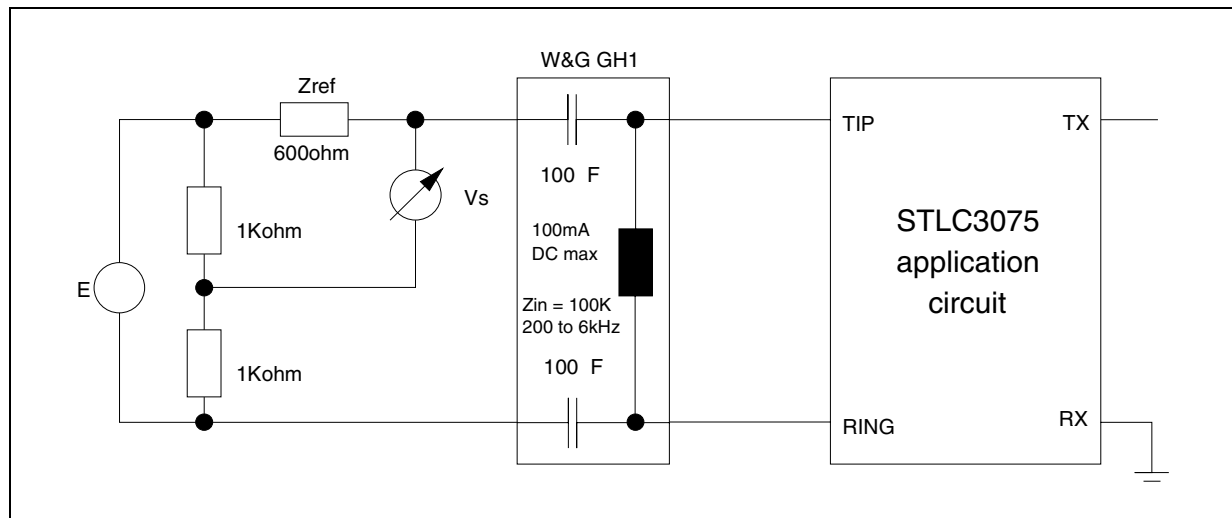

Figure 14. THL Trans Hybrid Loss

$$THL = 20\text{Log}|V_{rx}/V_{tx}|$$

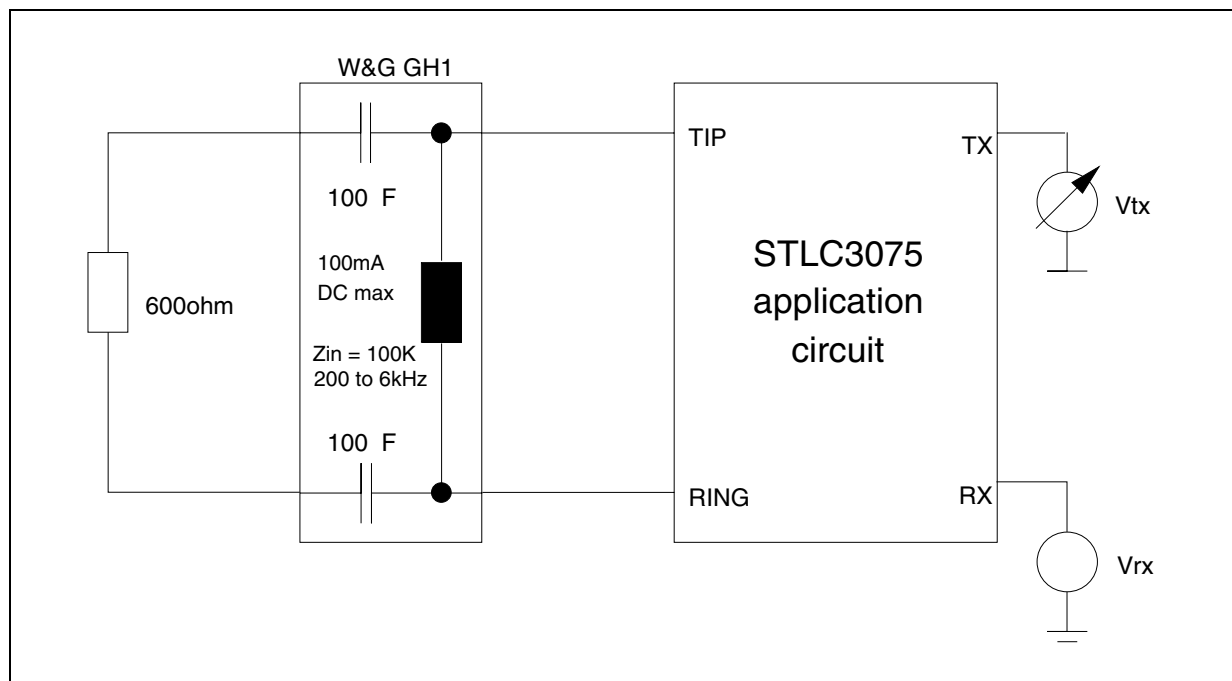

Figure 15. G24 Transmit Gain
 $G_{24} = 20\text{Log}|2V_{tx}/E|$

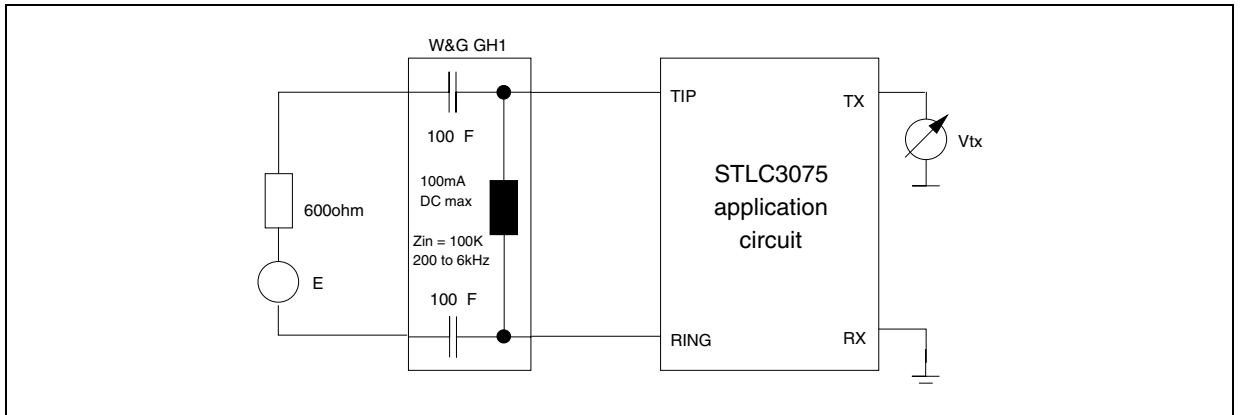

Figure 16. G42 Receive Gain
 $G_{42} = 20\text{Log}|V_I/V_{rx}|$

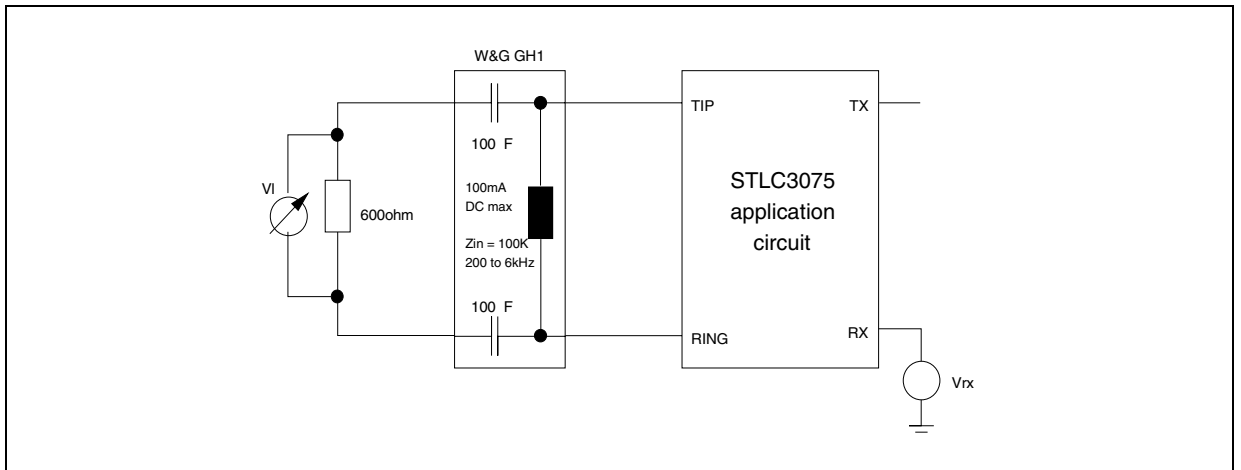

Figure 17. PSRRC Power supply rejection Vpos to 2W port
 $PSSRC = 20\text{Log}|V_n/V_{II}|$

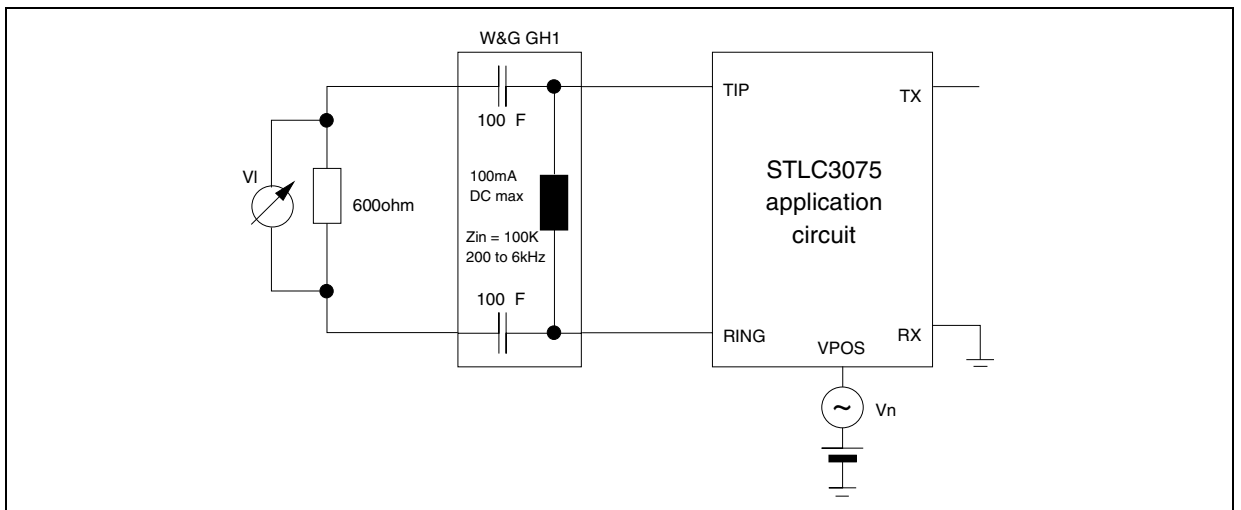

Figure 18. L/T Longitudinal to Transversal Conversion

$$L/T = 20\text{Log}|V_{cm}/V_I|$$

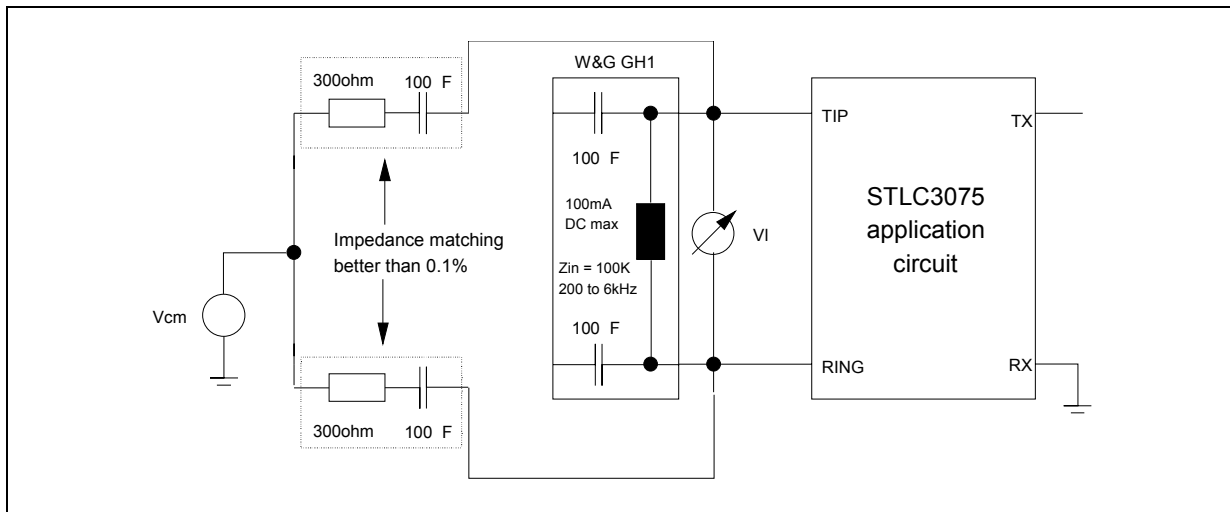

Figure 19. T/L Transversal to Longitudinal Conversion

$$T/L = 20\text{Log}|V_{rx}/V_{cm}|$$

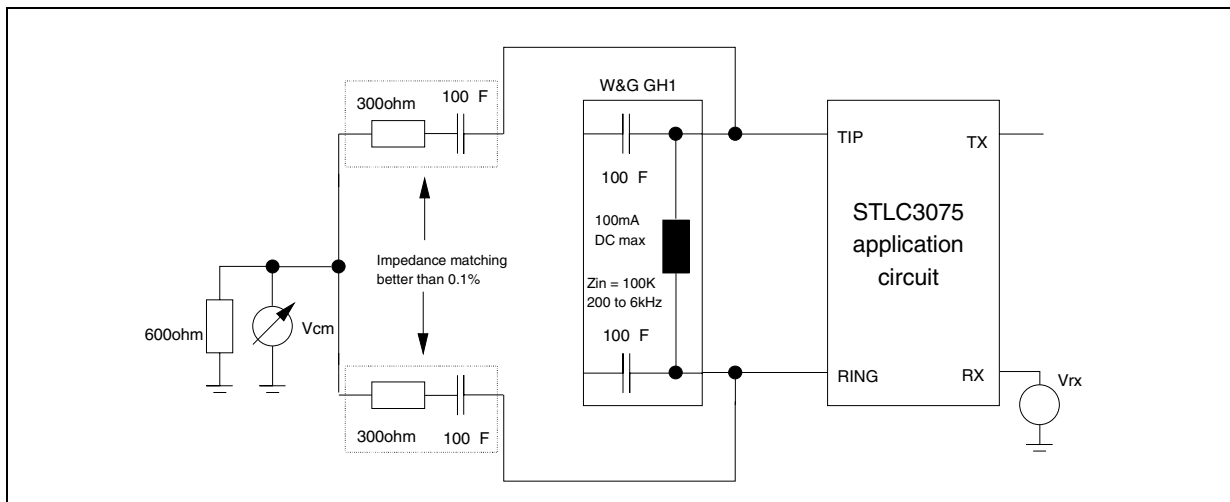

Figure 20. VTTX Metering Pulse level on line

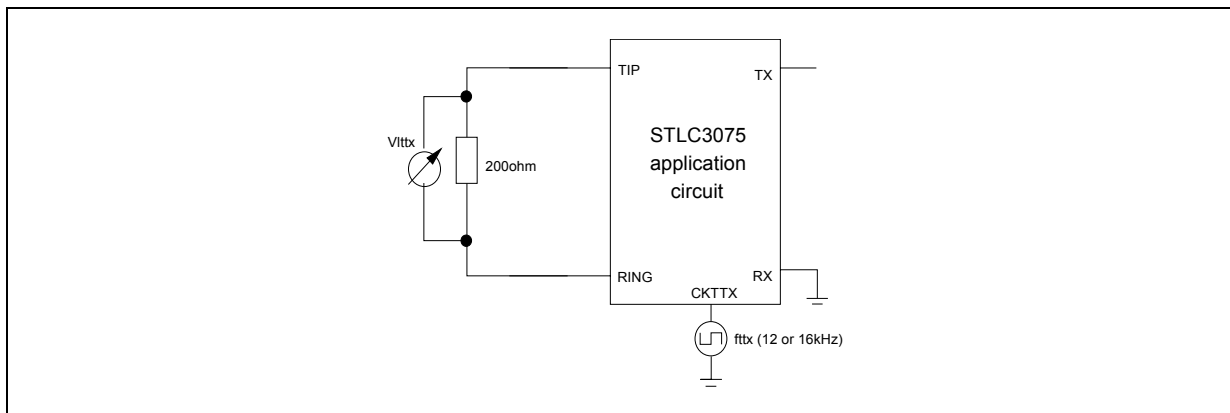
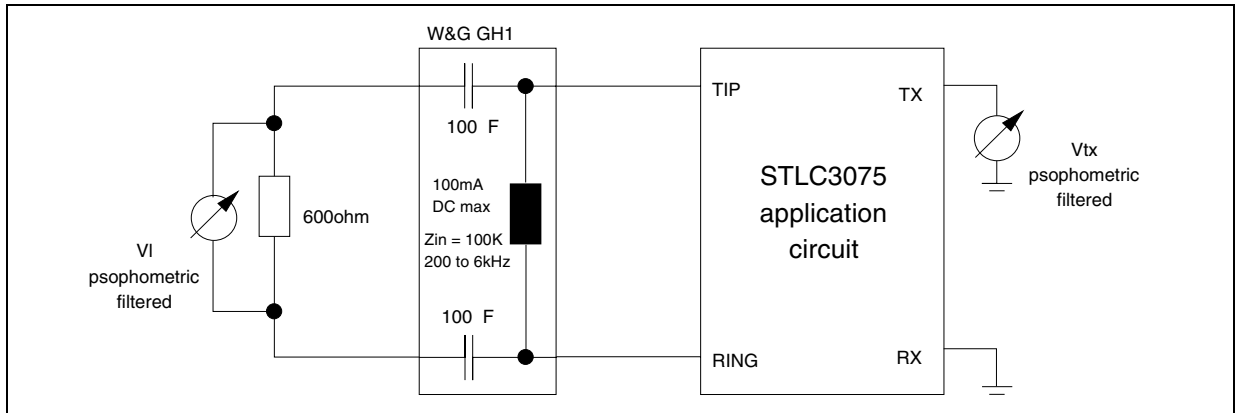

Figure 21. V2Wp and W4Wp: Idle channel psophometric noise at line and TX.

$$V2Wp = 20\text{Log}|V_I/0.774I|; V4Wp = 20\text{Log}|V_{tx}/0.774I|$$



6 APPENDIX B

6.1 STLC3075 Overvoltage Protection

Figure 22. Simplified configuration for indoor overvoltage protection

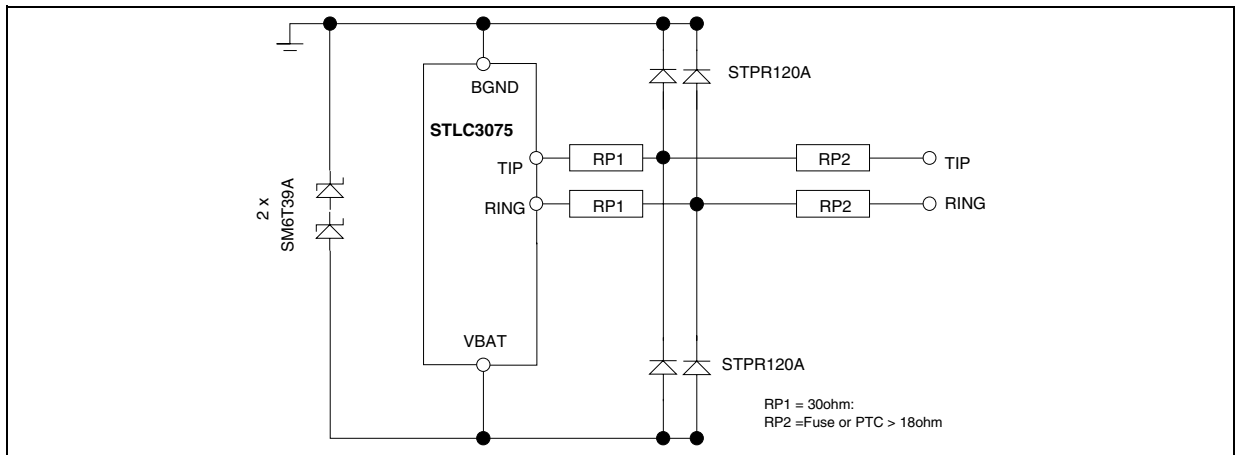
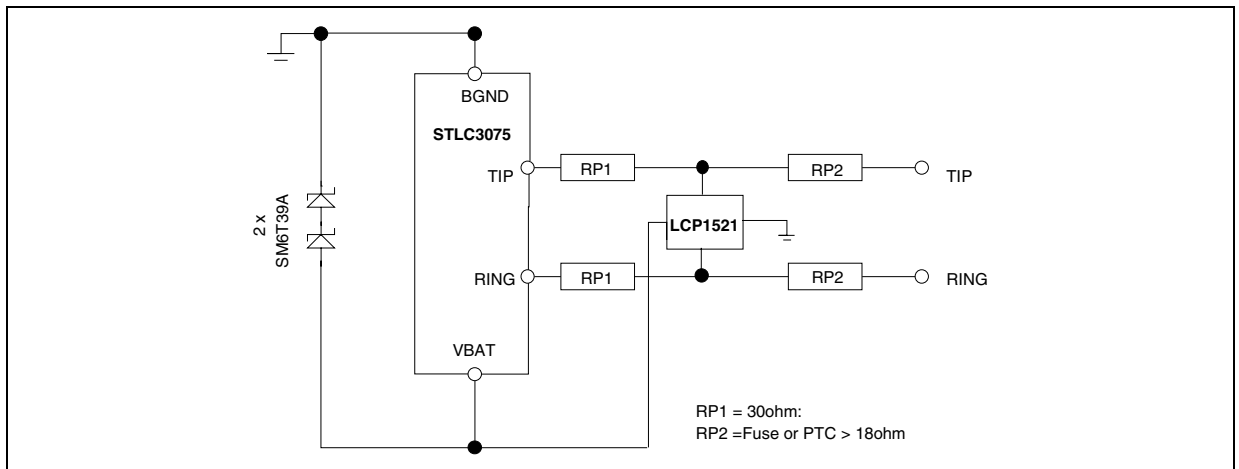

Figure 23. Standard overvoltage protection configuration for K20 compliance



7 APPENDIX C

7.1 TYPICAL STATE DIAGRAM FOR STLC3075 OPERATION

Figure 24.

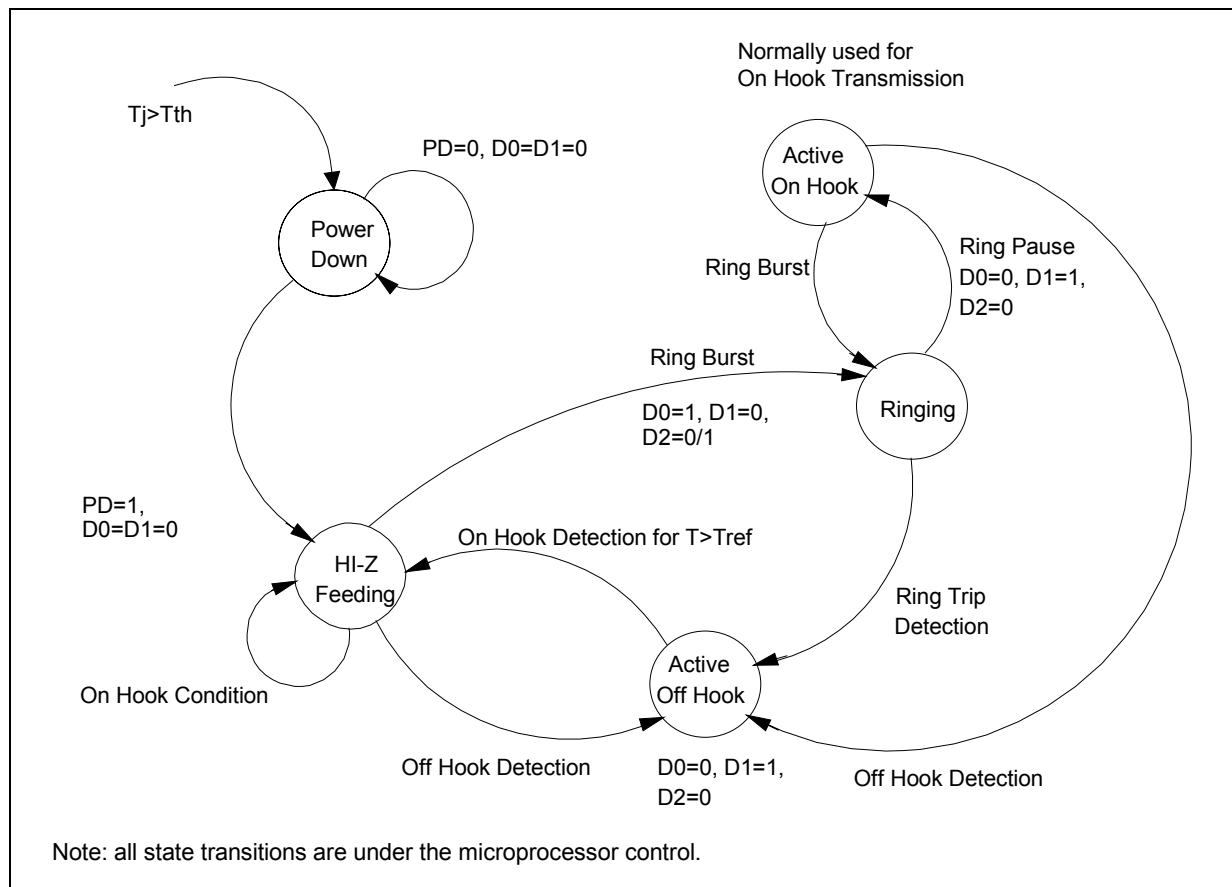
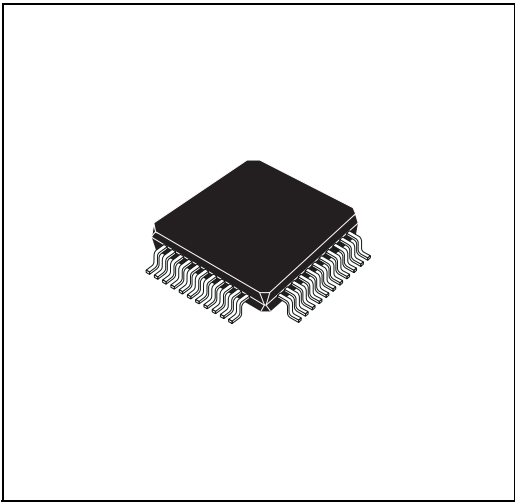

Figure 25. TQFP44 (10 x 10) Mechanical Data & Package Dimensions

DIM.	mm			inch		
	MIN.	TYP.	MAX.	MIN.	TYP.	MAX.
A			1.60			0.063
A1	0.05		0.15	0.002		0.006
A2	1.35	1.40	1.45	0.053	0.055	0.057
B	0.30	0.37	0.45	0.012	0.015	0.018
C	0.09		0.20	0.004		0.008
D	11.80	12.00	12.20	0.464	0.472	0.480
D1	9.80	10.00	10.20	0.386	0.394	0.401
D3		8.00			0.315	
E	11.80	12.00	12.20	0.464	0.472	0.480
E1	9.80	10.00	10.20	0.386	0.394	0.401
E3		8.00			0.315	
e		0.80			0.031	
L	0.45	0.60	0.75	0.018	0.024	0.030
L1		1.00			0.039	
k	0° (min.), 3.5° (typ.), 7° (max.)					

OUTLINE AND MECHANICAL DATA



TQFP44 (10 x 10 x 1.4mm)

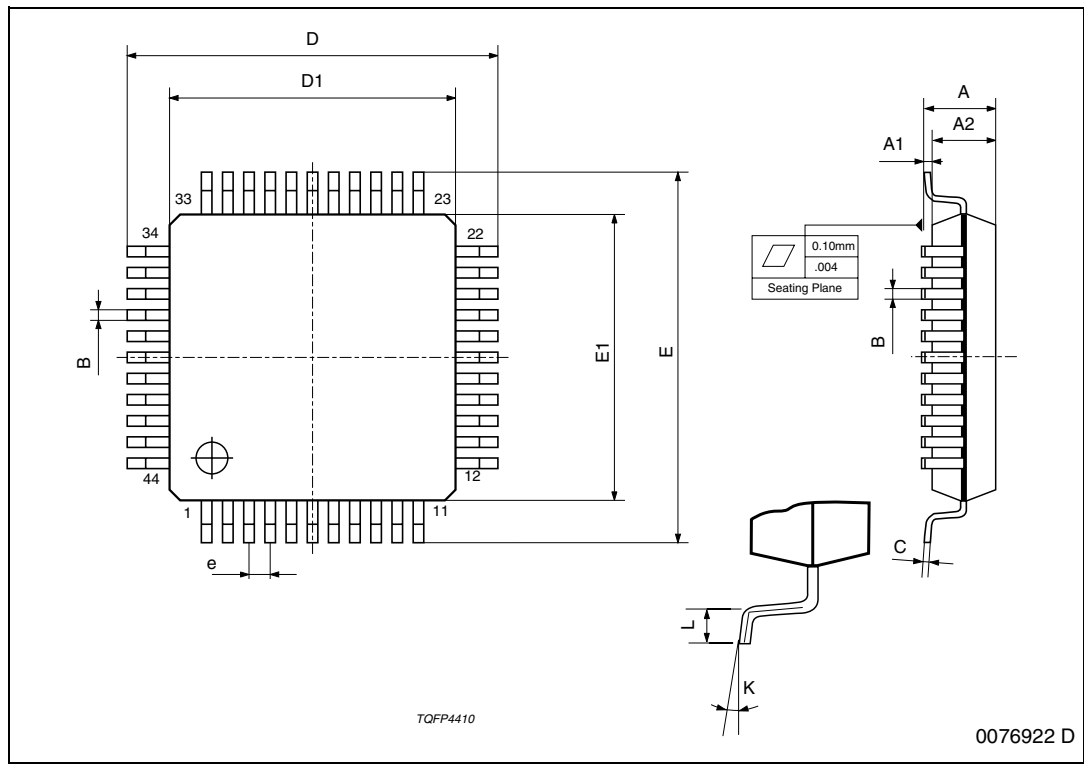

Table 14. Revision History

Date	Revision	Description of Changes
October 2004	1	First Issue
November 2004	2	Removed all max. values of the 'Line Voltage' parameter on the page 16/26. Changed the unit from mA to % of the 'Ilima' parameter on the page 16/26.
January 2005	3	Add pin 4 PD in Applications and Block Diagram . Add in Table 2 'ESD Rating'

Information furnished is believed to be accurate and reliable. However, STMicroelectronics assumes no responsibility for the consequences of use of such information nor for any infringement of patents or other rights of third parties which may result from its use. No license is granted by implication or otherwise under any patent or patent rights of STMicroelectronics. Specifications mentioned in this publication are subject to change without notice. This publication supersedes and replaces all information previously supplied. STMicroelectronics products are not authorized for use as critical components in life support devices or systems without express written approval of STMicroelectronics.

The ST logo is a registered trademark of STMicroelectronics.
All other names are the property of their respective owners

© 2005 STMicroelectronics - All rights reserved

STMicroelectronics group of companies

Australia - Belgium - Brazil - Canada - China - Czech Republic - Finland - France - Germany - Hong Kong - India - Israel - Italy - Japan -
Malaysia - Malta - Morocco - Singapore - Spain - Sweden - Switzerland - United Kingdom - United States of America

www.st.com