

UNCONTROLLED DOCUMENT

PART NUMBER		REV.
SSL-LX5093BHD		B
REV.	E.C.N. NUMBER AND REVISION COMMENTS	DATE
A	REDRAWN.	5.13.93
B	E.C.N. #10BRDR. & REDRAWN IN 3D.	5.29.01

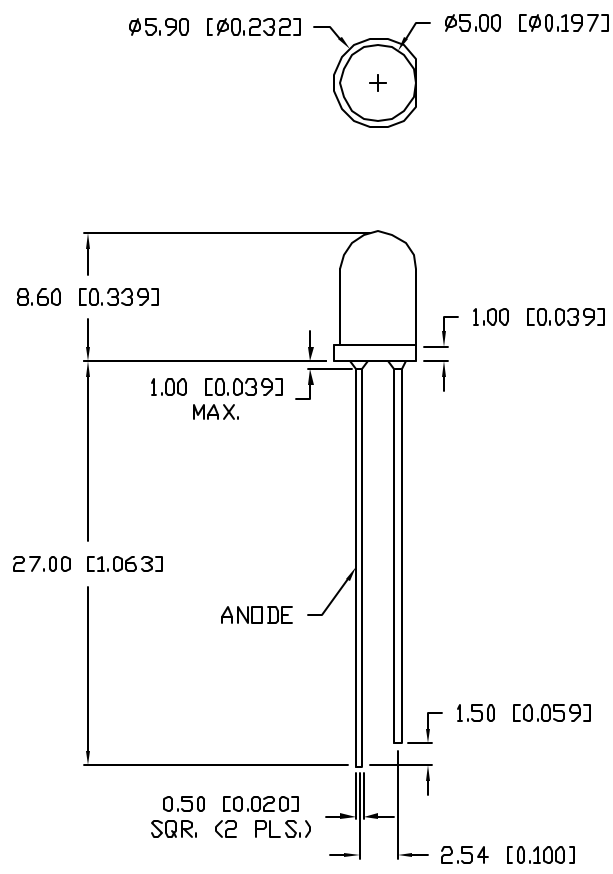

ELECTRO-OPTICAL CHARACTERISTICS $T_A=25^{\circ}\text{C}$

PARAMETER	MIN	TYP	MAX	UNITS	TEST COND
PEAK WAVELENGTH		700		nm	
FORWARD VOLTAGE		3.0	14.0	V_f	
BLINKING FREQUENCY:		1.5		Hz	$V_f=14.0, I_f=70\text{mA}$
		2.5		Hz	$V_f=3.0, I_f=6\text{mA}$
AXIAL INTENSITY		5		mcd	$V_f=9.0$
VIEWING ANGLE		60		2x theta	
EMITTED COLOR:		RED			
EPOXY LENS FINISH:		RED DIFFUSED			

LIMITS OF SAFE OPERATION AT 25°C

PARAMETER	MAX	UNITS
PEAK FORWARD CURRENT*	70	mA
STEADY CURRENT	20	mA
POWER DISSIPATION	105	mW
DERATE FROM 25°C	-1.2	mW/ $^{\circ}\text{C}$
OPERATING, STORAGE TEMP.	-40 TO +85	$^{\circ}\text{C}$
SOLDERING TEMP.	+260	$^{\circ}\text{C}$
2.0mm FROM BODY		3 SEC. MAX

* $t < 10\mu\text{s}$

*UNLESS OTHERWISE SPECIFIED TOLERANCES PER DECIMAL PRECISION ARE: X=±1 (±0.039), X.X=±0.5 (±0.020), X.XX=±0.25 (±0.010), X.XXX=±0.127 (±0.005). LEAD SIZE=±0.05 (±0.002), LEAD LENGTH=±0.75 (±0.030). MIN= ^{+0.00} -0.00 DECIMAL PRECISION MAX= ^{+0.00} -0.00 DECIMAL PRECISION

UNCONTROLLED DOCUMENT

REV.	PART NUMBER
B	SSL-LX5093BHD
T-5mm (T-1 3/4) BLINKING 700nm RED LED, RED DIFFUSED LENS.	

CONFIDENTIAL INFORMATION
 THE INFORMATION CONTAINED IN THIS DOCUMENT IS THE PROPERTY OF LUMEX INC. EXCEPT AS SPECIFICALLY AUTHORIZED IN WRITING BY LUMEX INC., THE HOLDER OF THIS DOCUMENT SHALL KEEP ALL INFORMATION CONTAINED HEREIN CONFIDENTIAL AND SHALL PROTECT SAME IN WHOLE OR IN PART FROM DISCLOSURE AND DISSEMINATION TO ALL THIRD PARTIES.

RELIABILITY NOTE
 OUR MANY YEARS OF EXPERIENCE DATA ACCUMULATION INDICATE THAT SOLDER HEAT IS A MAJOR CAUSE OF EARLY AND FUTURE FAILURE. PLEASE PAY ATTENTION TO YOUR SOLDERING PROCESS.



290 E. HELEN ROAD
 PALATINE, IL 60067-6976
 PHONE: +1.847.359.2790
 US WEB: www.lumex.com
 TW WEB: www.lumex.com.tw

DRAWN BY:	CHECKED BY:	APPROVED BY:	DATE: 5.13.93
BC			PAGE: 1 OF 1
			SCALE: N/A